

J. De La Mar Sheet 1-3 Sheets.

Mach. for Blocking & Stretching Hats

N^o 108116.

Patented Oct. 11. 1870

Fig. 1.

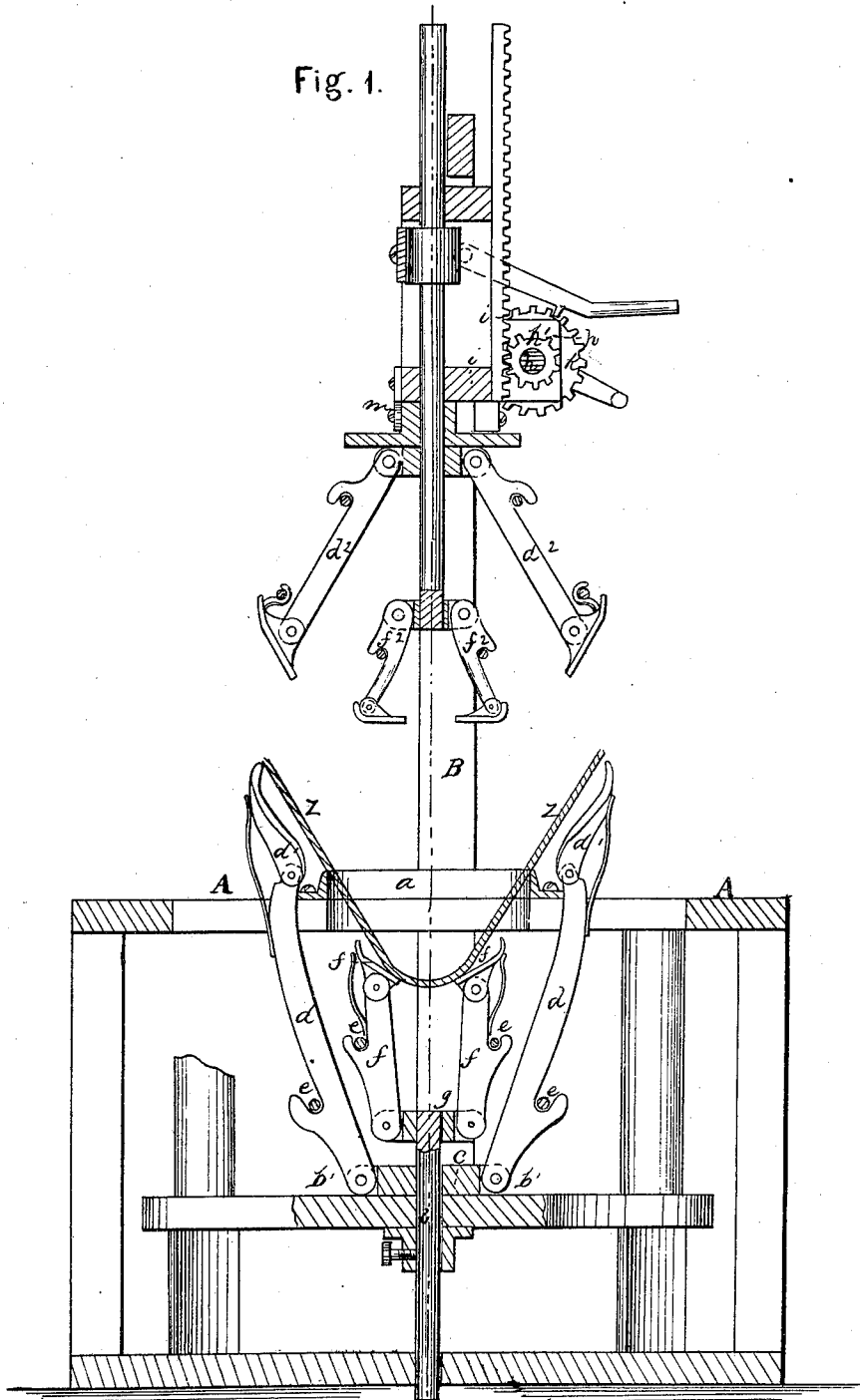

Witnesses
Stephen Clarke
J. Greenough

Inventor
Joseph de la Mar

J. De La Mar

Sheet 2. 3 Sheets

Mach. for Blocking & Stretching Hats

N^o 108116

Patented Oct. 11. 1870.
Fig. 2.

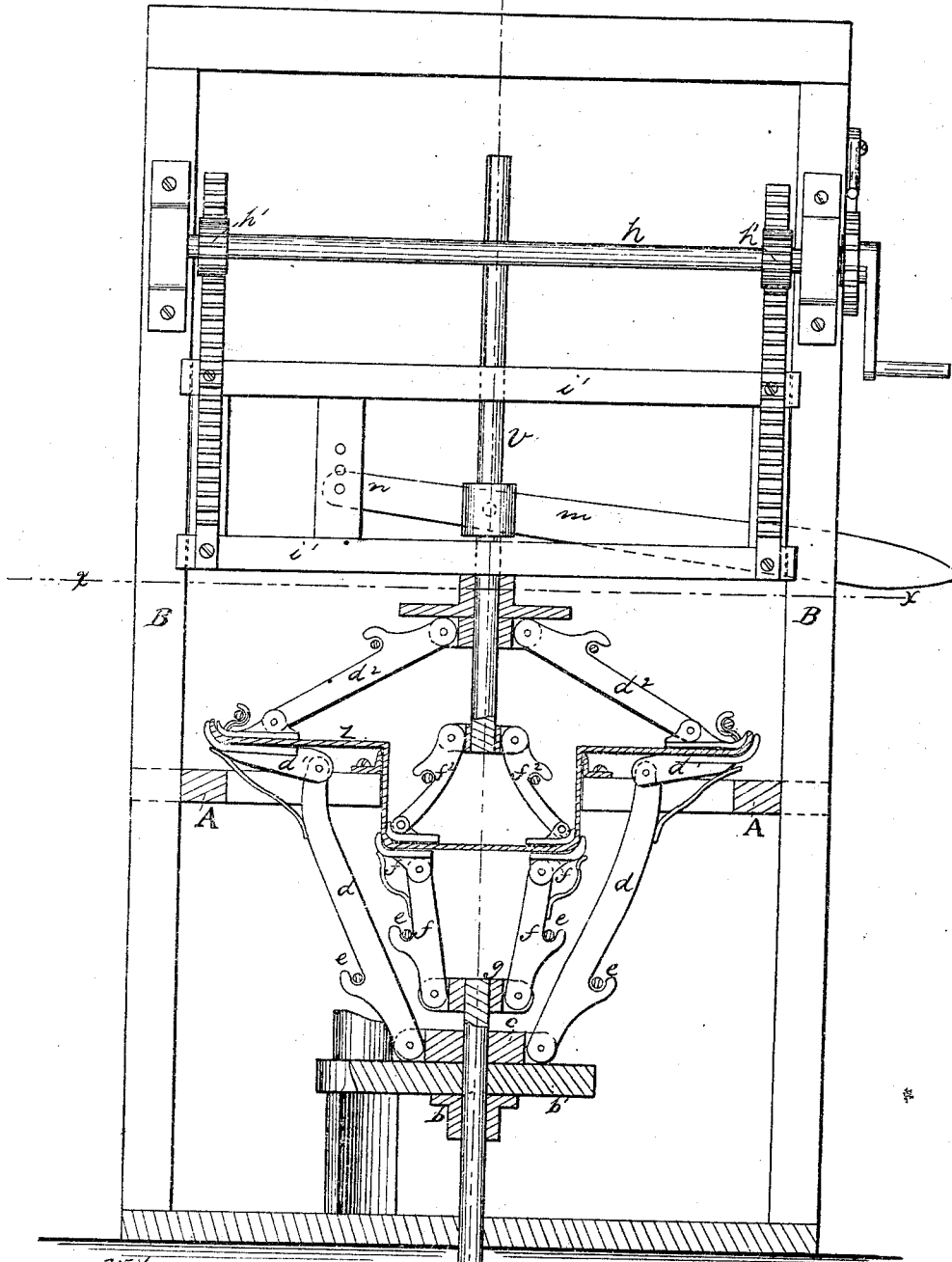

Witnesses
Stephen C. Clarke
J. Greenough

Inventor
Joseph de la Mar

J. DeLaMar Sheet 3. 3 Sheets.

Mach for Blocking & Stretching Hats.

N^o 108116.

Patented Oct. 11. 1870.

Fig. 3.

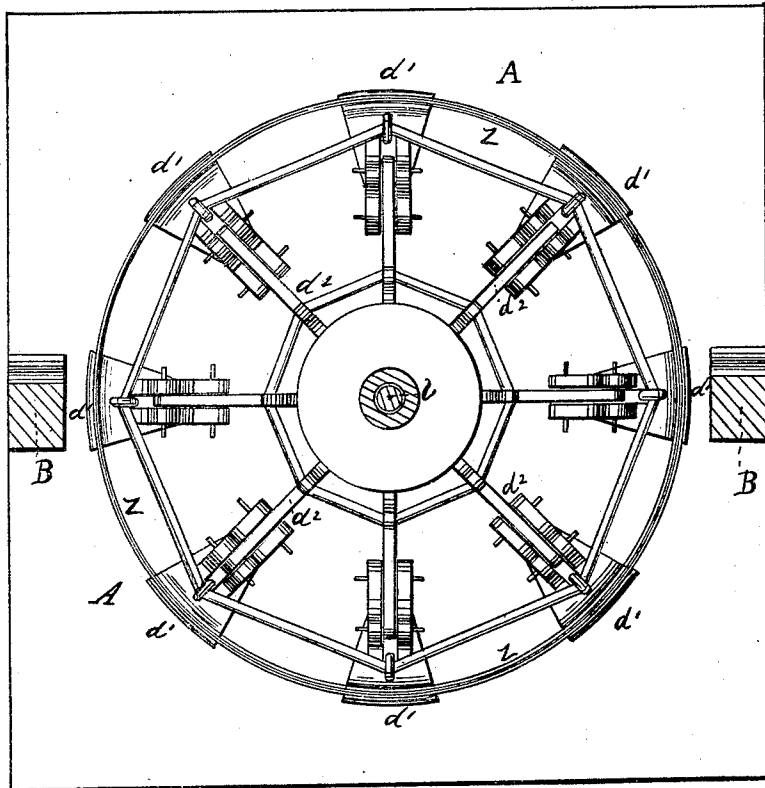

Witnesses

Stephen L. Clark
J. J. Greenough

Inventor

Joseph de la Mar

United States Patent Office.

JOSEPH DE LA MAR, OF BROOKLYN, NEW YORK, ASSIGNOR TO HIMSELF
AND JOHN DE VRIES ECKHOFF, OF NEW YORK CITY.

Letters Patent No. 108,116, dated October 11, 1870; antedated September 24, 1870.

IMPROVEMENT IN MACHINES FOR BLOCKING AND STRETCHING HATS.

The Schedule referred to in these Letters Patent and making part of the same.

Be it known that I, JOSEPH DE LA MAR, of Brooklyn, in the county of Kings and State of New York, have invented certain new and useful Improvements in Machinery for Blocking Hats; and I do hereby declare and ascertain my said invention as follows, referring to the accompanying drawings, in which—

Figure 1 represents a vertical central section of my improved machine, exhibiting its working parts in the position to receive a hat-body to be blocked, which is shown in red outlines.

Figure 2 is a vertical central section of the same, the plane of section taken at right angles to the plane taken in fig. 1, and the parts shown in position when the body is ready blocked.

Figure 3 is a horizontal section of the same, and the plane of section indicated by the line $x x$ in fig. 2.

Similar letters of reference indicate corresponding parts in the several figures.

The nature of this invention consists in the employment of a stationary ring for supporting the band of the hat-body, and in the employment of two series of outwardly-yielding levers, with jaws, between which the tip of the body is clamped, and, while clamped, stretched out, to block the crown of the hat; and of the employment of two series of yielding levers, with jaws hinged near the outside edge of the banding-ring; between which, by a motion of the two series of levers and jaws, the brim part of the hat-body is clamped, and, while clamped, is stretched out and turned over the edge of the said banding-ring, and the brim of the hat formed and blocked, in one continuous stretching operation, over the whole body with forming the crown of the hat.

To enable others skilled in the art to make and use my invention, I will proceed to describe its construction and operation.

A represents the frame of the machine, which supports the working parts, and is made with two vertical guide-posts, B B, and a horizontal table, with a central opening, upon the edge of which I secure the metal banding-ring a . By means of having a flange on this banding-ring, resting upon the table of the frame A, I secure the said ring to the said table. The top edge of this ring serves to support the body in forming the band of the hat in the usual way.

Now, in order to stretch out the tip and brim part of the body, I employ a series of levers, $f f$, and a series of levers, $d d$, with jaws, $f^1 f^1$ and jaws $d^1 d^1$, which are hinged on their outside ends to act on the outside of the body; and I employ a similar series of correspondingly-arranged levers, $f^2 f^2$ and $d^2 d^2$, with similar jaws on their loose ends, to act on the inside of the body, and meet with the jaws $f^1 f^1$ and $d^1 d^1$.

The levers $d d$ and $f f$ are hinged in the lower part of the frame A to cross-heads C and g , whereas the levers $d^2 d^2$ and $f^2 f^2$ are hinged to cross-heads at-

tached to a vertical-sliding frame, i , which latter is guided in the posts B B, and can be raised or lowered from or to the said table by means of a horizontal shaft, h , guided in bearings fixed on the posts B B, and having upon this shaft h pinions gearing in vertical rack-bars secured upon the said sliding frame i , so as to afford every access in placing the hat-body in the machine. The fulcrums of these levers are arranged in a circle which is smaller than that described by the outside ends of the levers.

Each series of levers is furnished with a circular spring, shown at e and e' , to bring the respective series of levers home to a normal position after every operation of the same; and, to bring home to a like position the jaws of the levers, I secure flat springs on the levers $f f$ and $d d$, pressing against the back of the said jaws $d^1 d^1$ and $f^1 f^1$.

The jaws of the levers $d^2 d^2$ I provide with a circumferential spring, and the jaws on the levers $f^2 f^2$ are brought home by their own weight.

The cross-head g is attached to a vertical shaft, b , which can be raised or lowered and secured, in order to set the levers $f f$ and jaws $f^1 f^1$ to the desired distance from the edge of the ring a , so as to adjust the machine to make the desired height of crown of the hat to be blocked.

The cross-head to which the levers $f^2 f^2$ are hinged is secured to a vertical sliding shaft, v , which is guided in the center of the vertical-sliding frame i , and is connected with a lever, m , having its fulcrum, at n , in the said frame i , whereby the said shaft can be moved up or down.

The cross-head C is secured with the stationary cross-bar b' , and the cross-head to which the levers $d^2 d^2$ are hinged is secured with the sliding frame i .

The jaws $d^1 d^1$ are so hinged with the levers $d d$ that their fulcrums are nearly in the same plane, and are close to the upper edge of the ring a , when the levers are in their contracted position.

k is a ratchet-wheel, fixed on the shaft h , to work with a pawl fixed or hinged on the respective post B, for the purpose of stationing the shaft h and sliding frame i whenever desired.

When a body is to be blocked, it is placed, with its tip downward, on the ring a , as shown in fig. 1. The pawl, engaging the ratchet k , is disengaged, and the sliding frame i is made to descend, so that the jaws on the levers $d^2 d^2$ press and clamp the brim part t of the body upon the jaws $d^1 d^1$. The sliding frame i is now secured again by placing the said pawl in the ratchet k . Pressure is now applied to the levers $f^2 f^2$ and their jaws by the lever m , so as to clamp the tip of the body upon the jaws $f^1 f^1$, and, by increased pressure of the lever, the loose ends of the levers $f f$ and $f^2 f^2$ are forced to expand on account of their outward inclined position, thereby forcing the tip of the

body to stretch out, which pressure is continued until the crown of the hat is obtained, as shown in fig. 2. I now disengage again the said pawl from the ratchet *k*, and apply power with the shaft *h*, to force the sliding frame down lower, so that the jaws *d' d'* are forced to turn down, whereby the brim of the body is turned over the edge of the ring *a*, and by still more pressure the levers *d d* and *d' d'* are forced outward to a larger circumference, and forcing the respective jaws to stretch the brim out, as shown in fig. 2, whereby the body is completely stretched and blocked.

The frame *i* is now again raised, and the blocked hat-body removed, and the said jaws and levers are allowed to fall back to their original position, ready to receive another body to be blocked.

I do not claim, broadly, a ring or circular edge, on which the band of the body is broken, and which serves, in general, for supporting the band of the body, while the body is being blocked, and its band formed, in hat-blocking machines; but

What I do claim as my invention, and desire to secure by Letters Patent, is—

1. The within-described arrangement of levers *d d'*, and their connections, adapted for stretching a hat-body by clamping and forcing outward, substantially as and for the purposes herein set forth.

2. The within-described arrangement of levers *d d'* and *f f'* in two sets, adapted, the one for clamping and stretching the brim, and the other for clamping and stretching the tip of a hat-body, as herein specified.

3. The hinged jaws, arranged, as represented, on the outer ends of the clamping and stretching-levers, for the purposes herein specified.

4. The within-described arrangement of the two sets of clamping and stretching-levers *d d' f f'*, with a fixed band-ring, for the purposes herein set forth.

JOSEPH DE LA MAR.

Witnesses:

STEPHEN G. CLARKE,
J. J. GREENOUGH.