

(19) World Intellectual Property
Organization
International Bureau



(43) International Publication Date
6 May 2004 (06.05.2004)

PCT

(10) International Publication Number
WO 2004/038809 A2

- (51) International Patent Classification⁷: **H01L 31/00**, H04N 3/00, H01L 21/00
- (21) International Application Number: PCT/GB2003/004577
- (22) International Filing Date: 23 October 2003 (23.10.2003)
- (25) Filing Language: English
- (26) Publication Language: English
- (30) Priority Data: 0224689.0 23 October 2002 (23.10.2002) GB
- (71) Applicant (for all designated States except US): **GOLD-POWER LIMITED** [—/—]; Sea Meadow House, P.O. Box 116, Blackburne Highway Road, Town Tortola (VG).
- (72) Inventors; and
- (75) Inventors/Applicants (for US only): **PUHAKKA, Kimmo** [FI/—]; c/o GoldPower Limited, P.O. Box 116, Blackburne Highway Road, Town Tortola (VG). **BENSON, Iain** [GB/—]; c/o GoldPower Limited, P.O. Box 116, Blackburne Highway Road, Town Tortola (VG).
- (74) Agent: **SPAARGAREN, Jerome**; Electronic Intellectual Property, Suite 308, The Foundry, 156 Blackfriars Road, London SE1 8EN (GB).
- (81) Designated States (national): AE, AG, AL, AM, AT, AU, AZ, BA, BB, BG, BR, BY, BZ, CA, CH, CN, CO, CR, CU, CZ, DE, DK, DM, DZ, EC, EE, ES, FI, GB, GD, GE, GH, GM, HR, HU, ID, IL, IN, IS, JP, KE, KG, KP, KR, KZ, LC, LK, LR, LS, LT, LU, LV, MA, MD, MG, MK, MN, MW, MX, MZ, NI, NO, NZ, OM, PG, PH, PL, PT, RO, RU, SC, SD, SE, SG, SK, SL, SY, TJ, TM, TN, TR, TT, TZ, UA, UG, US, UZ, VC, VN, YU, ZA, ZM, ZW.
- (84) Designated States (regional): ARIPO patent (GH, GM, KE, LS, MW, MZ, SD, SL, SZ, TZ, UG, ZM, ZW), Eurasian patent (AM, AZ, BY, KG, KZ, MD, RU, TJ, TM), European patent (AT, BE, BG, CH, CY, CZ, DE, DK, EE, ES, FI, FR, GB, GR, HU, IE, IT, LU, MC, NL, PT, RO, SE, SI, SK, TR), OAPI patent (BF, BJ, CF, CG, CI, CM, GA, GN, GQ, GW, ML, MR, NE, SN, TD, TG).
- Published:**
— without international search report and to be republished upon receipt of that report
- For two-letter codes and other abbreviations, refer to the "Guidance Notes on Codes and Abbreviations" appearing at the beginning of each regular issue of the PCT Gazette.

(54) Title: FORMATION OF CONTACTS ON SEMICONDUCTOR SUBSTRATES

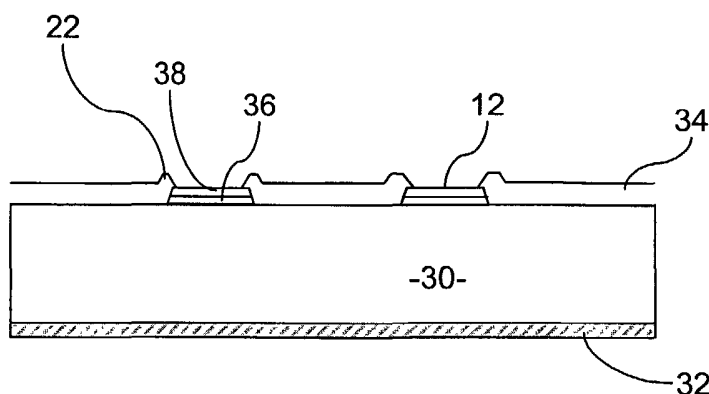

(57) Abstract: Embodiments of the invention are concerned with a method of manufacturing a radiation detector having one or more conductive contacts on a semiconductor substrate, and comprise the steps of: applying a first conductive layer to a first surface of the semiconductor substrate; applying a second conductive layer to form a plurality of contiguous layers of conductive materials, said plurality of contiguous layers including said first conductive layer; and selectively removing parts of said plurality of contiguous layers so as to form said conductive contacts, the conductive contacts defining one or more radiation detector cells in the semiconductor substrate.

WO 2004/038809 A2

Formation of Contacts on Semiconductor Substrates

Field of the Invention

The invention relates to methods of manufacturing radiation detectors and
5 radiation imaging devices, radiation detectors and imaging devices manufactured by
these methods and the use of such imaging devices.

Background of the Invention

A radiation detector for an imaging device typically comprises a semiconductor
10 substrate with a pattern or array of conductive contacts on one surface of the substrate
defining an arrangement of detector cells.

Various semiconductor materials can be used in radiation detectors. For
example, for optical wavelengths and charged radiation (beta-rays), silicon has
typically been used for the semiconductor substrate material, while cadmium zinc
15 telluride (CdZnTe), cadmium telluride (CdTe), titanium bromide (TiBr), mercury
iodide (HgI) and gallium nitride (GaN) can be used as substrate material in X-ray,
gamma-ray and to a lesser extent beta-ray radiation imaging.

Such detector substrates need to be processed to produce a detector having a
pattern of conductive contacts (e.g. pixel pads) on one surface, so that the detector may
20 be position sensitive; that is, to ensure that the detector can produce a detector output
indicating the position at which radiation impacts the detector. A readout chip then
can be 'flip-chip' joined to the patterned side of the detector (e.g., by bump bonding
using low temperature soldering with tin lead bismuth (PbSnBi) alloy solder or using
balls of indium or conductive polymer material, gluing using conductive materials or
25 other conductive adhesive layer techniques) so that the position dependent electrical
signals which result from incidence and absorption in the detector cells of beta-rays,
X-rays or gamma-rays for example, can be processed.

In some known radiation detectors, problems have been observed with certain
characteristics of the conductive contacts. These include the conductive contacts
30 having poor adhesion properties and shorter than desired life times. Shorter than
desirable life times have been observed when radiation detectors are joined to a

readout chip in a radiation imaging device, via a bump bonding technique using either a lead-based or a lead-free solder, for example.

It is therefore desirable to provide a method that produces radiation detectors with improved electrical properties.

5

Summary of the Invention

In accordance with one aspect of the invention, there is provided a method of manufacturing a radiation detector having one or more conductive contacts on a semiconductor substrate, the method including the steps of:

10 applying a first conductive layer to a first surface of the semiconductor substrate;

applying a second conductive layer to form a plurality of contiguous layers of conductive materials, said plurality of contiguous layers including said first conductive layer; and

15 selectively removing parts of said plurality of contiguous layers so as to form said conductive contacts, the conductive contacts defining one or more radiation detector cells in the semiconductor substrate.

In one arrangement the first layer is a contact layer and the second layer is a diffusion barrier layer, which means that embodiments can provide particularly good
20 chemical contact with the substrate (via the contact layer) and improved lifetime (via the diffusion barrier layer). In some embodiments the conductive contacts additionally include either or both of a third conductive layer and a further conductive layer, the third being sandwiched between the first and second layers and the further being adjacent the second layer. The third layer acts as an adhesion layer, whilst the further
25 layer acts as a wetting agent for the bump bonding. Advantageously, the diffusion barrier (second) layer prevents bump bond material (e.g. PbSnBi solder) from diffusing into layers beyond the diffusion barrier layer, which is detrimental to the lifetime of the detector.

Preferably, the conductive layers are applied by methods such as sputtering,
30 evaporation, electrolytic deposition, or electroless deposition (e.g. chemical deposition), before any subsequent layers are formed. An advantage of forming the

plurality of contiguous layers of conductive materials first (i.e. before applying an insulating layer such as a passivation layer) is that this can improve electrical contact characteristics, reduce hotspots, improve yield and improve detector quality. Homogenous contacts with even electrical contacts can thus be reliably produced.

5 In one arrangement, the method of forming the plurality of contiguous layers of conductive materials involves:

- (a) forming a layer of photoresistive material on said substrate surface;
- (b) selectively exposing said photoresistive material and removing said photoresistive material from areas corresponding to said contact positions to expose
10 said semiconductor substrate surface;
- (c) applying said plurality of layers of conductive materials on remaining photoresistive material and on said exposed semiconductor substrate surface; and
- (d) removing conductive material overlying said remaining photoresistive material by removing said remaining photoresistive material (this process being
15 commonly called "lift-off").

The surface resistivity of cadmium-based substrates in particular, for example a CdZnTe semiconductor substrate, is degraded when the substrate is exposed to metal etchants suitable for removing gold and/or platinum, for example. As a result of this, the electrical separation of the individual contacts which result from some known
20 methods of forming such contacts is not as good as would be expected from the properties of that material before treatment. By using a lift-off method in accordance with the invention, metal etchants need not be used, thus avoiding the damage which would result if the metal etchants came into contact with the semiconductor surface.

Preferably the method includes forming a layer of passivation material on said
25 conductive contacts and the regions around conductive contacts; and

removing portions of said passivation material overlying said conductive contacts to expose the conductive contacts.

The removal of portions of said passivation material overlying said conductive contacts to expose the conductive contacts can involve: forming a further layer of
30 photoresistive material over said passivation layer; selectively exposing regions of said further layer of photoresistive material; and removing portions of the further photoresistive material corresponding to the exposed regions so as to expose portions

of said passivation layer corresponding to said contact positions. The exposed portions of passivation layer are then removed, and finally any remaining further photoresistive material is also removed.

An advantage of applying the further layer of photoresistive material is that areas of varying size, specifically, smaller or larger than the contact positions, can be exposed, which means that portions of the layer of passivation material can be removed from areas smaller than the conductive contacts. After this removal of portions of said passivation layer, the passivation material can overlap with the conductive contacts. This means that the passivation material may be applied over portions of the conductive contacts, providing good mechanical contact, and reducing the possibility of gaps being formed between the conductive material and passivation material.

In one arrangement, the further photoresistive material is removed from areas of passivation material in order to expose said areas in a desired pattern for forming conductive tracks.

To protect the other main surface and the sides (edges) of the semiconductor substrate, photoresistive material can additionally be applied to all exposed surfaces as well as the surface on which the conductive contacts are formed.

Preferably, the first and second layers comprise different metals, while the third and further layers comprise the same metal. For example, in one arrangement the contact (first) layer comprises platinum, the adhesion (third) layer comprises gold, the diffusion barrier (second) layer comprises nickel and the wetting agent (further) layer comprises gold.

Each conductive contact so formed can define a respective pixel cell of an array of pixel cells, or one of a plurality of strips arranged parallel to each other. Pixel contacts formed on detector substrate are preferably substantially circular and are arranged in a plurality of rows, more preferably with alternate rows preferably being offset from adjacent rows. In one arrangement, conductive contacts can be from about $5\mu\text{m}$ to about $100\mu\text{m}$ across with a pitch from about $7\mu\text{m}$ to about $500\mu\text{m}$. Preferably, the conductive contacts are of the order of $15\mu\text{m}$ across with a pitch of the order of $35\mu\text{m}$.

According to a second aspect of the invention there is provided a radiation detector having a semiconductor substrate, comprising:

a plurality of conductive contacts arranged along the semiconductor substrate, the conductive contacts defining one or more radiation detector cells in the
5 semiconductor substrate,

wherein each of the conductive contacts comprises a plurality of contiguous layers of conductive materials comprising a first conductive layer and a second conductive layer.

A radiation detector in accordance with this second aspect of the invention
10 finds particular, but not exclusive, application for X-ray, gamma-ray and beta-ray imaging, and one particular embodiment of the invention can provide a method for manufacturing detectors (e.g. a cadmium based substrate such as CdTe or CdZnTe) with one side uniformly metallised with a metal such as indium or platinum and the other side patterned with conductive contacts structures (e.g. a platinum/ gold/ nickel/
15 gold stack) in a manner that does not adversely affect the surface characteristics of the substrate around or in between the contacts. Thus, a method can be provided for creating conductive structures on one side of a detector, the method achieving inter-structure resistivity of the order of $G\Omega$ /square or tens or hundreds of $G\Omega$ /square. The conductive contact structures can be patterned to provide readout tracks, for example.

20 Preferably the radiation detector includes an electrically insulating passivation layer between contacts distributed on the semiconductor substrate, which enables the area between metal contacts to be protected, thus giving the detector stable performance over time and avoiding effects such as oxidation which increase the surface leakage current and decrease the inter-contact resistivity. Aluminium nitride
25 (AlN) passivation has been found to be particularly effective when applied between gold contacts to protect the surface and enhance the electrical separation of the gold contacts. The passivation layer of aluminium nitride can be implemented at relatively low temperatures typically less than 100°C . By contrast, silicon oxide (SiO_2), which is typically used as a passivant for silicon (Si) semiconductors, needs temperatures in
30 excess of 200°C . After exposure to these temperatures, CdZnTe would be unusable.

Embodiments in accordance with the present invention may be used to define areas or regions away from, yet operatively related to, contact positions. This is

particularly advantageous and is intended for use in manufacturing high energy (1KeV) radiation imaging devices since it allows more complex conductive material patterns to be formed (e.g. for spatially off-setting a charge collection contact of a detector cell relative to a corresponding contact of a read-out substrate cell).

5 In accordance with another aspect of the invention, there is provided a radiation detector comprising a semiconductor substrate for detecting radiation with a plurality of conductive contacts for respective radiation detector cells on a first surface thereof and a layer of conductive material on a surface of said substrate opposite to said first surface, wherein the exposed width of a said conductive contact is smaller than the overall width of said contact adjacent said substrate, and wherein the conductive
10 contacts comprise a plurality of contiguous metallic layers.

Brief Description of the Drawings

Embodiments of the invention will be described hereinafter, by way of
15 example only, with reference to the accompanying drawings in which:

Figures 1A – 1J are schematic diagrams showing an example of a method of forming metal contacts on a semiconductor substrate with a passivation layer between contacts according to an embodiment of the invention;

20 Figures 2A and 2B are schematic diagrams showing examples of detector substrates manufactured according to an embodiment of the invention;

Figure 3 is a schematic plan view of a contact configuration on a detector substrate;

Figure 4 is a schematic plan view of another contact configuration on a detector substrate;

25 Figure 5 is a schematic plan view of a further contact configuration on a detector substrate; and

Figure 6 is a schematic cross-section of a radiation imaging device manufactured according to an embodiment of the invention.

30 Detailed Description of the Drawings

Figures 1A – 1J show the steps involved in forming conductive contacts on a semiconductor substrate according to an embodiment of the invention. In the figure the contacts define discrete radiation detector cells, which have a layer of passivation material between the detector cells. The semiconductor substrate may be made of any suitable semiconductor material including, but not limited to, cadmium zinc telluride (CdZnTe), cadmium telluride (CdTe), lead iodide, thallium bromide, gallium arsenide or silicon. As shown in the Figures, the material used for the conductive layer and the contacts comprise a sequence or stack of layers of two or more different metals.

Each of Figures 1A – 1J is a schematic cross-sectional view from the side of a detector substrate at various stages in the formation of conductive contacts on a semiconductor substrate.

- Step A: One face (the lower face in Figure 1) of the detector substrate 1 is uniformly metallised with conductive material 2.
- Step B: Photoresistive material (photoresist) 4 is spun on a face opposing the face metallised in step A (the upper face in Figure 1) of the detector 1 and preferably on the sides of the detector.
- Step C: Openings 6 exposing the substrate surface are made in the photoresist 4 using an appropriate mask or other conventional technique for removing photoresist according to a desired pattern. The remaining photoresist is a negative profile of the positions for forming the conductive contacts and/or tracks (for a lift off process).
- Step D: A plurality of layers 8, 9 of conductive material is sputtered, evaporated or laid by electrolysis or electroless deposition (e.g. chemical deposition) uniformly over the exposed substrate surface (through openings 6) and the photoresist 4, as a result of which the conductive material covers the photoresist 4 and the exposed substrate surface.
- Step E: The remaining photoresist is removed, e.g. by dissolving with a solvent such as acetone, thereby lifting off unwanted conductive material areas 10 to expose areas of the substrate surface between conductive contacts 12.

- Step F: Passivation material 14 is sputtered over the exposed areas of the substrate surface and over the conductive contacts 12.
- Step G: A further layer of photoresist 16 is spun on the passivation layer 14.
- 5 Step H: Photoresist layer 16 is removed in portions to expose portions 18 of the passivation layer overlying the conductive contacts. The removed portions of the photoresist layer 16 and consequently the exposed portions 18 are slightly smaller in area than the area of the conductive contacts 12.
- 10 Step I: Openings 20 are made through the exposed portions of the passivation layer with a passivation etchant (e.g. an aluminium nitride etchant) to expose the conductive contacts 12. The exposed area of the conductive contacts is slightly smaller than the entire available area of the upper surface of the conductive
- 15 contacts 12 themselves.
- Step J: The remaining photoresist is removed. The passivation material slightly overlaps the conductive contacts 12 (in regions 22), which means that the exposed area of each conductive contact 12 is smaller than the area of the contact 12 at the interface
- 20 between the contact and the semiconductor substrate 1. These overlapping regions ensure that there are no gaps between the passivation material and the contacts 12. In the embodiment shown the passivation material extends up and onto the contacts.

In the described method photoresist may additionally be applied to the sides and/or the lower face of the detector to provide protection during the process described

25 above (e.g. at step B); any additional photoresist on the sides can then be removed at a later stage (e.g. at step J).

Non-limiting examples of particular embodiments of the invention will now be described.

30

EXAMPLE 1

Referring to Figure 1J, cadmium zinc telluride or cadmium telluride is used as the semiconductor substrate 1 and a platinum or indium metallisation layer is used as the conductive material 2 on the lower face of the detector in step A. The conductive layers 8, 9 in step D are formed by evaporation or electroless deposition of platinum and PVD sputtering of gold to form a stack or sequence of platinum and gold with the platinum formed on the substrate surface and the gold formed on the platinum. The passivation material 14 in step F is sputtered aluminium nitride formed by phase vapour deposition. In step I an alkali solution is used to etch the aluminium nitride.

The end result is a cadmium zinc telluride/cadmium telluride substrate 30, a platinum or indium layer 32, an aluminium nitride passivation layer 34, and conductive contacts formed as a stack of platinum and gold layers 36, 38.

EXAMPLE 2

Referring to Figure 2A, cadmium zinc telluride or cadmium telluride is used as the semiconductor substrate 1, and an indium metallisation layer is used as the conductive material 2 on the lower face of the detector in step A. The conductive layers 8, 9 in step D form a stack of platinum, gold, nickel and gold. The passivation material 14 in step F is sputtered aluminium nitride formed by phase vapour deposition. In step I alkali solution is used to etch the aluminium nitride.

The end result is a cadmium zinc telluride/cadmium zinc substrate 40, an aluminium nitride passivation layer 44 and conductive contacts formed as a stack of platinum, gold, nickel and gold 45, 46, 47, 48.

EXAMPLE 3

This example corresponds to Example 2 except that the conductive contacts are formed as a stack of platinum 45, gold 46, indium 47 and gold 48.

EXAMPLE 4

Referring to Figure 2B, cadmium zinc telluride or cadmium telluride is used as the semiconductor substrate 1, and a platinum metallisation layer is used as the conductive material 2 on the lower face of the detector in step A. The conductive layers 8, 9 in step D comprise a stack of nickel and gold. The passivation material 14

in step F is sputtered aluminium nitride formed by phase vapour deposition. In step I alkali solution is used to etch the aluminium nitride.

The end result comprises a cadmium zinc telluride/cadmium zinc substrate 50, a platinum layer 52, an aluminium nitride passivation layer 54 and conductive contacts
5 formed as a stack of nickel 55 and gold 56.

In other examples, stacks of platinum/gold/nickel; platinum/gold; indium/gold; chrome/copper/gold and platinum/titanium-tungsten alloy/gold are used.

Embodiments of the invention produce a detector with a lower face having a uniform conductive layer (e.g. a metallised layer such as a gold layer) and an upper
10 face having conductive contacts in a desired pattern, and avoids the introduction of impurities from the passivation material and/or passivation etchant (e.g. aluminium nitride etchant) between the semiconductor substrate and the conductive contacts and into the conductive layer. The method eradicates the need to apply an etchant to the
15 conductive layers (e.g. a gold etchant), and ensures that there is no contact between the passivation etchant and the substrate surface in the area between the conductive contacts or the edges and sides of the detector. As a consequence, the surface of the substrate between the conductive contacts remains unharmed, retaining very high resistivity of the order of $G\Omega$ /square, tens, hundreds or even thousands of $G\Omega$ /square and very low surface leakage current.

20 High resistivity between conductive contacts is desirable in order to achieve long integration standby or readout times of the signal created from impinging X-rays or gamma-rays, for example, without deterioration of the image resolution. By covering the areas between conductive contacts with passivation material (e.g. Aluminium nitride) the corresponding regions are protected from oxidation (providing
25 stability over time), which enhances the inter-contact resistivity. Since the passivation material overlaps with the conductive contacts, there are no gaps on the semiconductor substrate surface, which increases the mechanical stability of the detector.

With the above described methods, contact pads up to about $100\mu\text{m}$ across with up to about $500\mu\text{m}$ pitch in between can be readily obtained, while retaining very
30 high inter pixel resistivity.

Figures 3, 4 and 5 illustrate possible contact patterns of metal contacts on the upper surface of the detector substrate. In Figure 3, an array of square contact pads is

shown, while Figure 4 shows an array of circular contact pads. For any given size of metal contacts, the surface resistance between circular pads is greater than that between rectangular pads because the amount of resistive material between adjacent circular pads is greater. Figure 5 illustrates an array of offset (honeycombed) pixel
5 pads, and it can be seen that, in comparison with the regular spacing shown in Figure 4, offsetting metal contacts with respect to one another increases the amount of resistive material between adjacent pads, thereby increasing the resistance between contacts.

It will be appreciated that rather than providing an array of contacts for
10 defining an array of detector cells, other contact configurations, for example contact strips for defining strip-shaped detector cells, can be obtained with the same method.

Referring back to Figure 1J, it can be seen that the metal contacts are not rectangular (the length of the contact, in a direction parallel to the plane of the substrate, of the exposed face is smaller than that of the face adjacent the substrate
15 surface). This is due to the relative sizes of the openings to the contacts and of the contacts themselves and has the advantage that, when portions of the passivation material above the contacts are etched away, the etchant will not seep through to the interface between the passivation layer and the conductive contacts.

Figure 6 is a schematic cross section of part of a radiation imaging device 60.
20 Such radiation imaging devices are known and radiation detectors constructed in accordance with the embodiments of the present invention can be used within such a device. The radiation imaging device 60 comprises a radiation detector 62 and a readout chip 64 for reading charge from the conductive contacts 12 of the radiation detector 62. The radiation detector 62 comprises conductive contacts 12, which
25 comprise a plurality of contiguous conductive layers, on one surface (the upper surface in Figure 6) of a semiconductor substrate 1 and a layer of conductive material 2 on another surface (the lower surface in Figure 6) of the semiconductor substrate 1. The readout chip 64 comprises circuitry for reading charge from the contacts 12 in the form of respective readout circuits 66. Readout circuits 66 are joined to respective contacts
30 12 via bonds 68 and may be 'flip-chip' joined (e.g., by bump bonding using low temperature soldering with tin lead bismuth (PbSnBi) alloy solder or using balls of

indium or conductive polymer material, gluing using conductive materials, or other conductive adhesive layer techniques) to respective circuits.

The continuous conductive layer or electrode 2 and the conductive contacts 12 of the radiation imaging device 60 define detector cells 70. Corresponding readout circuits 66 for each detector cell are defined at locations corresponding to the detector cells 70. The readout circuits 66 are electrically connected to the corresponding contacts 12 by bonds 68 which form a conductive pathway. In this manner when charge is generated in a detector cell 70 in response to incident radiation, this charge is passed via the bond 68 to the corresponding readout circuit 66.

The readout chip may be any suitable readout chip. For example, the readout chip may be of the pulse counting type (e.g. photon counting) or one of the type which provides for charge accumulation for individual detector cells, such as that described in PCT/EP95/02056. In particular embodiments the readout chip may comprise one or more of: charge accumulation circuitry; counter circuitry; readout circuitry; energy discriminator circuitry; pulse shaping circuitry; pulse amplifying circuitry; analogue to digital converter circuitry; or rate divider circuitry.

Thus, the invention teaches how to obtain a radiation detector (e.g. based on a CdZnTe substrate) with one side metallised according to a desired pattern with maximum possible electrical resistivity separation between the metal contacts. High resistivity between metal contacts is desirable to improve contrast resolution and eliminate signal leakage between adjacent metal contacts on the substrate surface. This is particularly relevant when long charge accumulation times and long standby/readout times are employed by the readout chip. Such accumulation and standby/readout times could, for example, be in excess of 1msec in examples of imaging devices using a radiation detector manufactured in accordance with the present invention. Such imaging devices find application, for example, for X-ray, gamma-ray and beta-ray imaging as described in the applicant's International Patent Application PCT/EP 95/02056 incorporated herein by reference.

Although particular embodiments of the invention have been described by way of example, it will be appreciated that additions, modifications and alternatives thereto may be envisaged.

The present disclosure includes any novel feature or combination of features disclosed therein either explicitly or implicitly or any generalisation thereof irrespective of whether or not it relates to the claimed invention or mitigates any or all of the problems addressed by the present invention. The applicant hereby gives notice
5 that new claims may be formulated to such features during the prosecution of this application or of any such further application derived therefrom. In particular, with reference to the appended claims, features from dependent claims may be combined with those of the independent claims and features from respective independent claims may be combined in any appropriate manner and not merely in the specific
10 combinations enumerated in the claims.

Claims

1. A method of manufacturing a radiation detector having one or more
conductive contacts on a semiconductor substrate, the method including the steps of:
applying a first conductive layer to a first surface of the semiconductor
5 substrate;
applying a second conductive layer to form a plurality of contiguous layers of
conductive materials, said plurality of contiguous layers including said first conductive
layer; and
selectively removing parts of said plurality of contiguous layers so as to form
10 said conductive contacts, the conductive contacts defining one or more radiation
detector cells in the semiconductor substrate.
2. A method according to claim 1, including applying a third layer
between said first and second layers, said third layer being a conductive layer.
15
3. A method according to claim 1, including applying a further layer to the
second layer, said further layer being a conductive layer.
4. A method according to any one of the preceding claims, including
20 forming a layer of passivation material on said conductive contacts and the
regions around conductive contacts; and
removing portions of said passivation material overlying said conductive
contacts to expose the conductive contacts.
- 25 5. A method according to any one of the preceding claims, including:
forming a layer of photoresistive material on said substrate surface;
selectively exposing said photoresistive material and removing said
photoresistive material from areas corresponding to said contact positions to expose
said semiconductor substrate surface;

forming at least said first and second layers of conductive material on remaining photoresistive material and on said exposed semiconductor substrate surface; and

5 removing conductive material overlying said remaining photoresistive material by removing said remaining photoresistive material.

6. A method according to any one of the preceding claims, wherein the step of removing portions of said passivation material overlying said conductive contacts to expose the conductive contacts comprises:

10 forming a further layer of photoresistive material over said passivation layer; selectively exposing said further layer of photoresistive material and removing said further photoresistive material to expose portions of said passivation layer corresponding to said contact positions;

15 removing said exposed portions of passivation material; and removing remaining further photoresistive material.

7. A method according to any one of claim 5 or claim 6, wherein said portions of said passivation layer are removed from areas smaller than the size of said conductive contacts such that the passivation layer overlaps said conductive contacts.

20

8. A method according to any one of the preceding claims, wherein each of said first and second layers is applied by sputtering, evaporation, electrolytic deposition, or electroless deposition.

25 9. A method according to any one of the preceding claims, including forming a layer of conductive material on a surface of said substrate opposite to said first surface.

30 10. A radiation detector having a semiconductor substrate, comprising: a plurality of conductive contacts arranged along the semiconductor substrate, the conductive contacts defining one or more radiation detector cells in the semiconductor substrate,

wherein each of the conductive contacts comprises a plurality of contiguous layers of conductive materials comprising a first conductive layer and a second conductive layer.

5 11. A radiation detector according to claim 10, wherein the first layer is a contact layer arranged to provide chemical contact between the conductive contacts and the substrate.

10 12. A radiation detector according to claim 10 or claim 11, wherein the second layer is a diffusion barrier layer arranged to protect the substrate from parts adjacent said conductive contacts.

15 13. A radiation detector according to any one of claim 10 to claim 12, including a third conductive layer adjacent said first layer and said second layer.

 14. A radiation detector according to claim 13, wherein the third layer is an adhesion layer arranged to provide adhesion between said first and second layers.

20 15. A radiation detector according to any one of claim 10 to claim 14, including a further conductive layer adjacent said second layer.

25 16. A radiation detector according to claim 15, wherein the radiation detector includes a further semiconductor substrate, the further semiconductor substrate being connectable to the semiconductor substrate by charge receiving means, and said further conductive layer being a wetting agent arranged to provide chemical bonding between the conductive contacts and said charge receiving means.

30 17. A radiation detector according to any one of claim 10 to claim 16, wherein the first layer is of a different type of conductive material to that of the second layer.

18. A radiation detector according to any one of claim 10 to claim 17, wherein said first layer comprises platinum and the second layer comprises nickel.

19. A radiation detector according to any one of claim 10 to claim 17,
5 wherein said first layer comprises platinum and the second layer comprises gold.

20. A radiation detector according to claim 15 when dependent on claim 13, wherein the third and further layers are of the same type of conductive material as one another.

10

21. A radiation detector according to claim 20, wherein the third and further layers comprise gold.

22. A radiation detector according to any one of claim 10 to claim 21,
15 wherein each of the plurality of contiguous layers is one of nickel, gold, platinum, indium, titanium, tungsten, a nickel/gold alloy or a titanium/tungsten alloy.

23. A radiation detector according to any one of claim 10 to claim 22, including passivation material around individual conductive contacts.

20

24. A radiation detector according to any one of claim 10 to claim 23, wherein said conductive contacts define an array of pixel cells.

25. A radiation detector according to claim 24, wherein said contacts are
25 substantially circular and are arranged in a plurality of rows, with alternate rows preferably being offset from adjacent rows.

26. A radiation detector according to any one of claim 10 to claim 25,
wherein said conductive contacts define a plurality of strips arranged parallel to one
30 another.

27. A radiation detector according to any one of claim 10 to claim 26, wherein, in a direction parallel to the plane of the substrate, said conductive contacts are from about $5\mu\text{m}$ about to about $100\mu\text{m}$ in size and distributed with a pitch from about $7\mu\text{m}$ to about $500\mu\text{m}$.

5

28. A radiation detector according to any one of claim 10 to claim 27, wherein, in a direction parallel to the plane of the substrate, said conductive contacts are of the order of $15\mu\text{m}$ in size and distributed with a pitch of the order of $35\mu\text{m}$.

10 29. A radiation detector according to any one of claim 10 to claim 28, wherein the resistivity between conductive contacts is in excess of $1\text{G}\Omega/\text{square}$, preferably in excess of $10\Omega/\text{square}$, more preferably in excess of $100\text{G}\Omega/\text{square}$ and even more preferably in excess of $1000\text{G}\Omega/\text{square}$ ($1\text{T}\Omega/\text{square}$).

15 30. A radiation imaging device according to any one of claim 15 to claim 30, wherein said further semiconductor substrate comprises one or more of the following:

charge accumulation circuitry; counter circuitry; readout circuitry; energy discriminator circuitry; pulse shaping circuitry; pulse amplifying circuitry; analogue to digital converter circuitry; and rate divider circuitry.

25 31. A radiation detector comprising a semiconductor substrate having one or more conductive contacts for respective radiation detector cells on a first surface thereof and a layer of conductive material on a surface of said substrate opposite to said first substrate, each conductive contact having a first face adjacent the first surface of the substrate and a second face opposite the first face, wherein the second face has a smaller surface area than that of the first face.

30 32. A method of manufacturing a radiation imaging device comprising:

manufacturing a radiation detector in accordance with any one of claim 1 to claim 9; and

individually connecting individual detector cell contacts for respective detector cells to corresponding circuits on a readout chip.

FIG. 1A

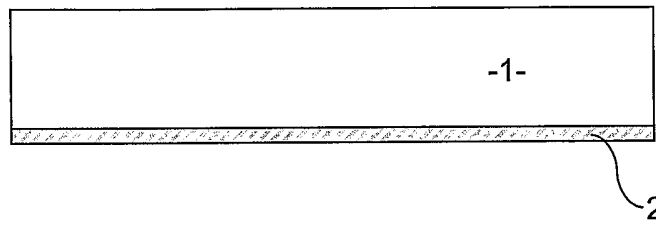

FIG. 1B

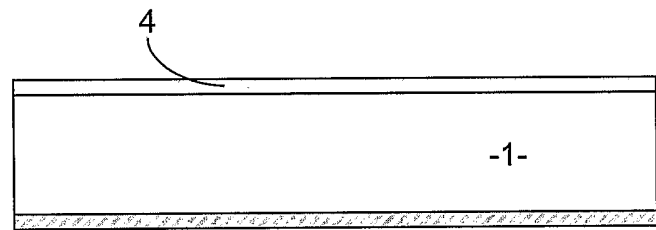

FIG. 1C

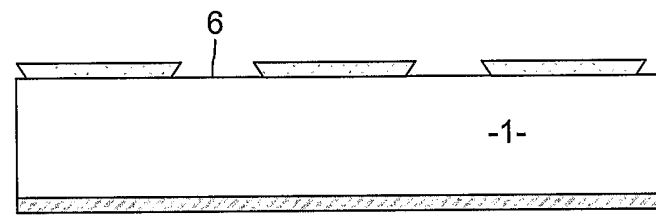

FIG. 1D

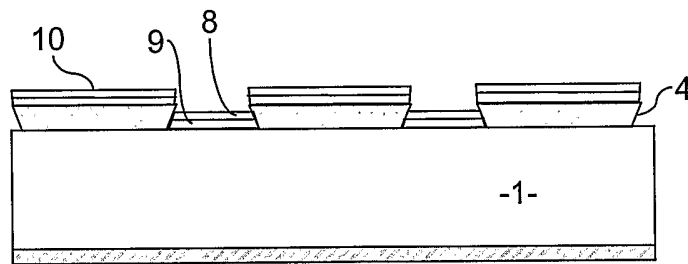
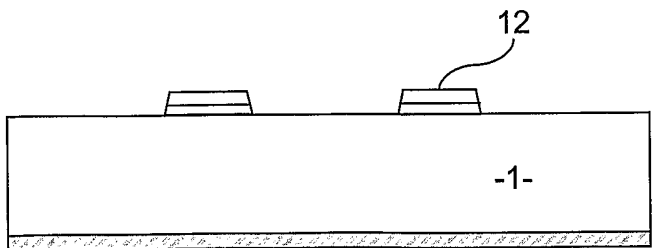
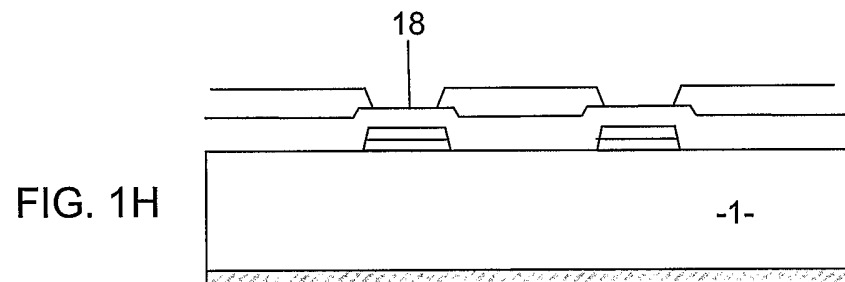
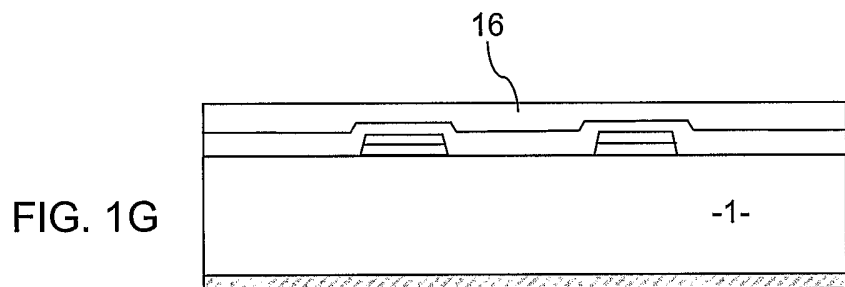
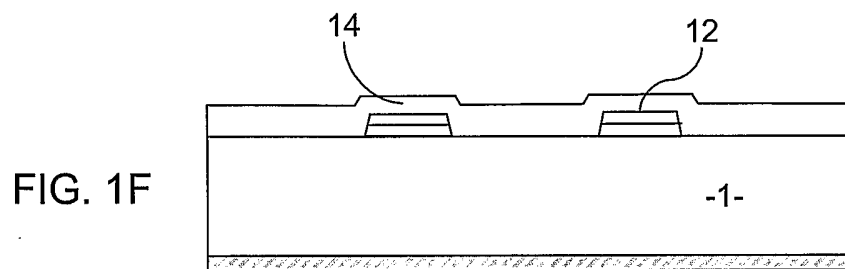
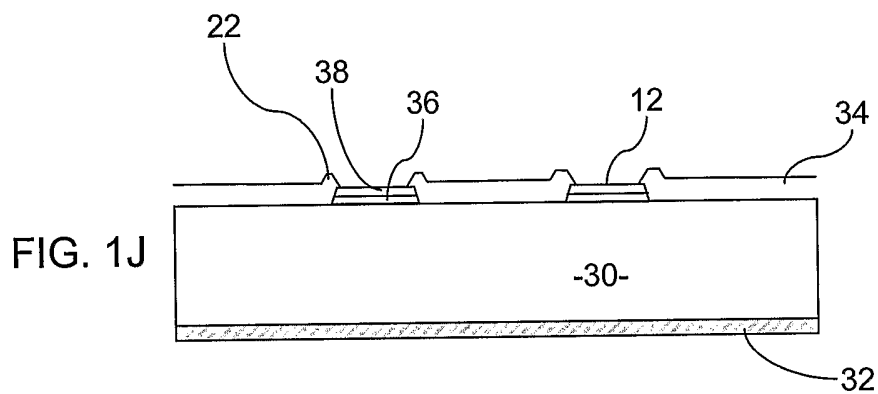
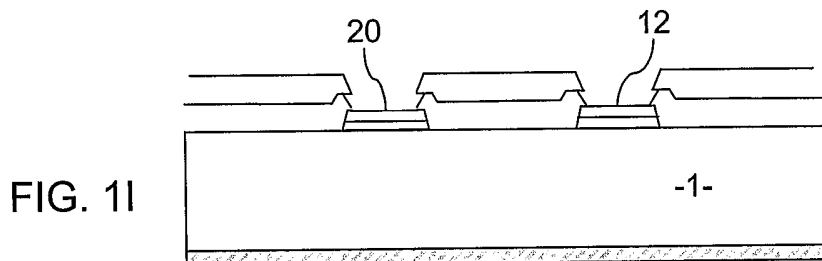

FIG. 1E



2/7





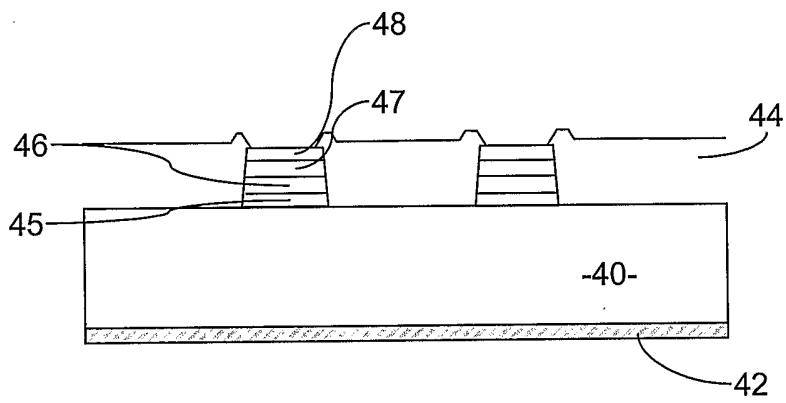

FIG. 2A

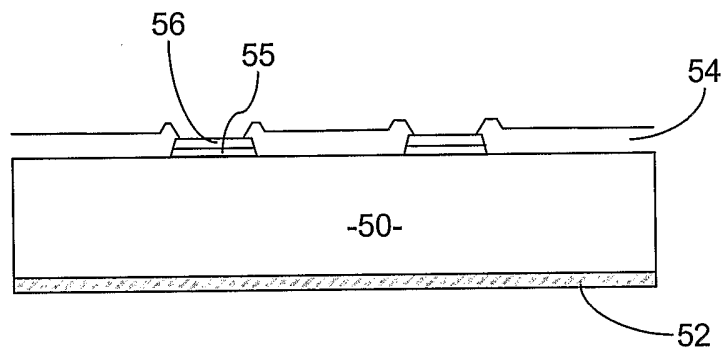

FIG. 2B

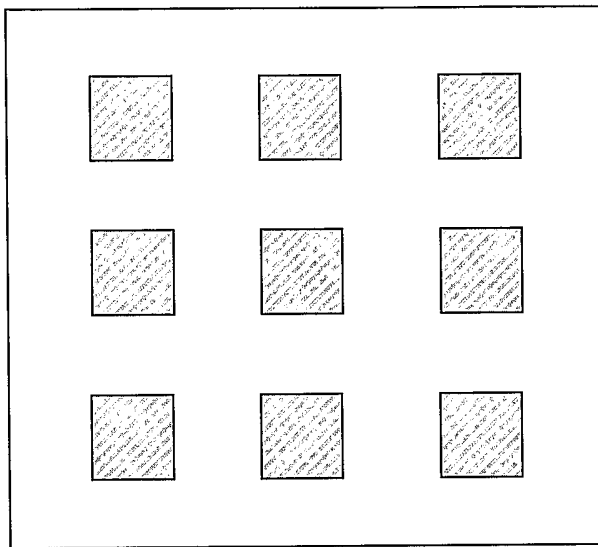

FIG. 3

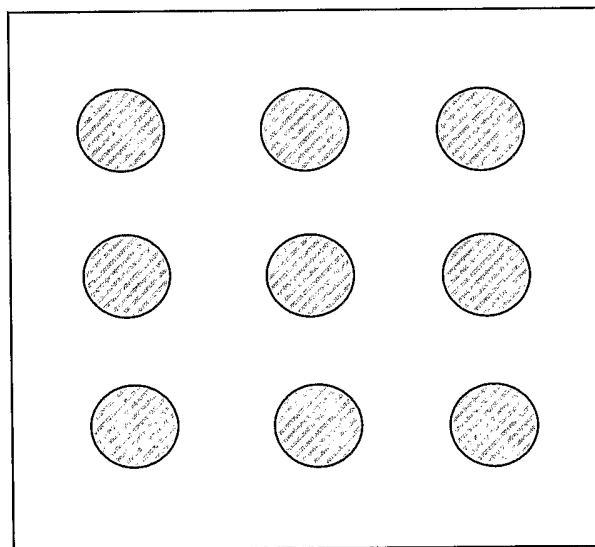

FIG. 4

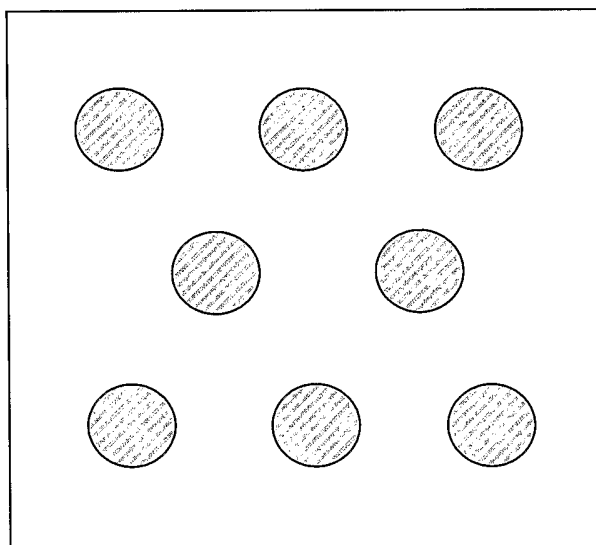

FIG. 5

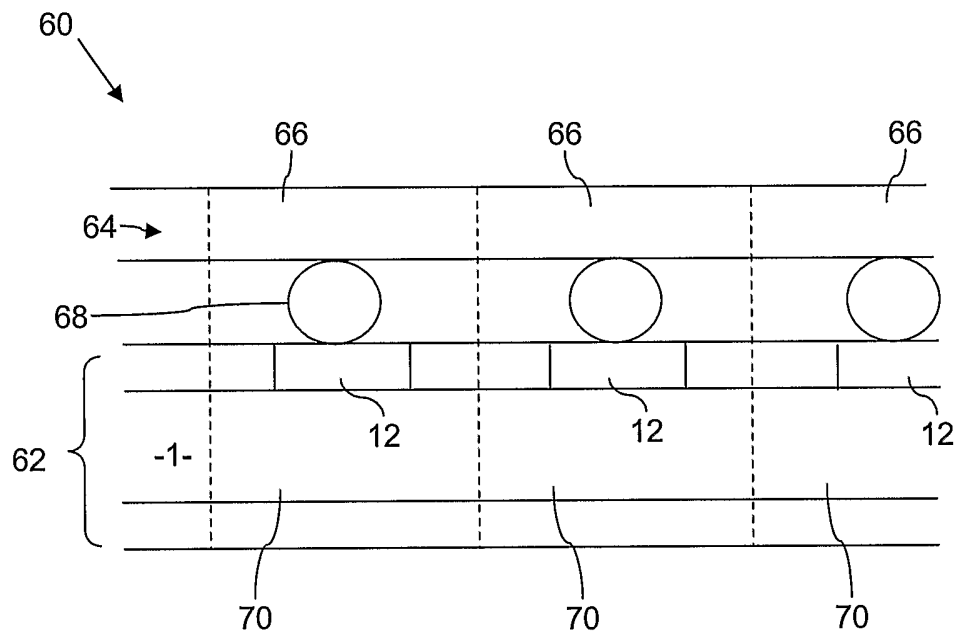

FIG. 6