

(No Model.)

T. I. WITTING.

DISPENSING APPARATUS FOR SODA WATER, &c.

No. 414,272.

Patented Nov. 5, 1889.

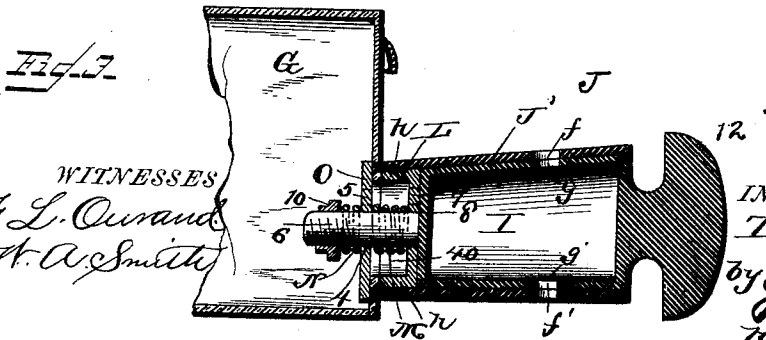
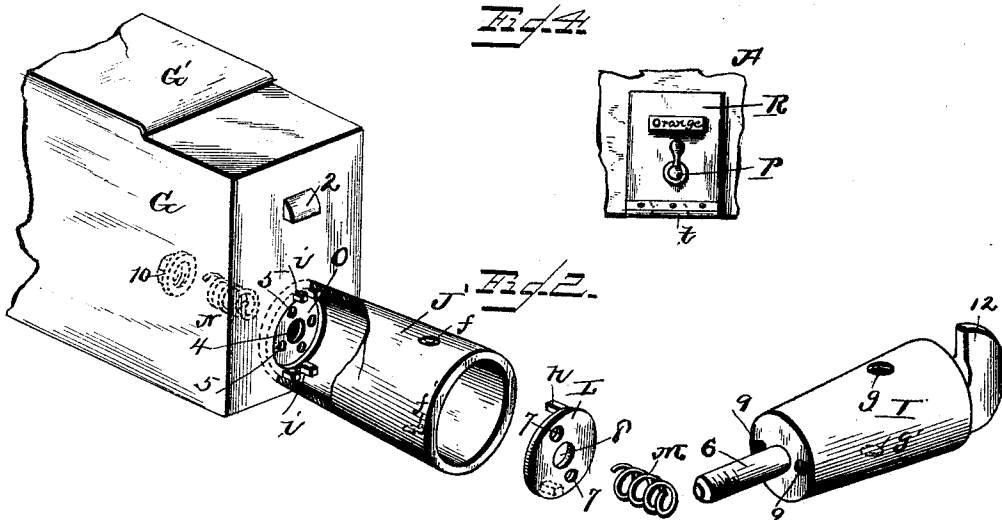
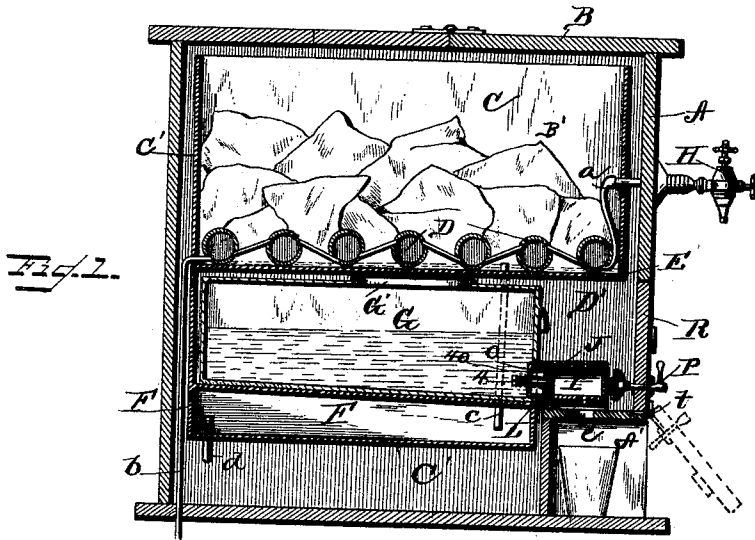

WITNESSES
J. L. Curran
H. A. Smith

INVENTOR
T. I. Witting
by J. C. Higdon
his Attorney.

UNITED STATES PATENT OFFICE.

THEODORE I. WITTING, OF LAWRENCE, KANSAS.

DISPENSING APPARATUS FOR SODA-WATER, &c.

SPECIFICATION forming part of Letters Patent No. 414,272, dated November 5, 1889.

Application filed August 7, 1888. Serial No. 282,136. (No model.)

To all whom it may concern:

Be it known that I, THEODORE I. WITTING, of Lawrence, Douglas county, State of Kansas, have invented certain new and useful Improvements in Dispensing Apparatus for Soda-Water, &c., of which the following is a full, clear, and exact description, reference being had to the accompanying drawings, forming a part hereof.

This invention relates to apparatus for dispensing soda and mineral waters; and it consists in the novel construction, combination, and arrangement of parts hereinafter set forth, and pointed out in the claims.

In the drawings which illustrate the manner of carrying out my invention, Figure 1 is a vertical transverse section of my apparatus. Fig. 2 is a broken detail view, in perspective, of a sirup-can and its attached self-measuring sirup-faucet used in making up the invention, the several parts of said faucet being shown detached and ready to put together. Fig. 3 is a broken vertical longitudinal section of a sirup can and faucet, on enlarged scale; and Fig. 4 is a broken front elevation of a portion of the outer case of the apparatus, having a door applied thereto.

A indicates the outer case, which is preferably rectangular in general contour, formed of marble slabs in the usual way, provided with recess A' at its lower front side, (for reception of glasses,) hinged or removable cover B, to afford access to the ice-chamber and arranged with a suitable number of drop-doors R, which are located immediately above said recess to afford access to the sirup-can chamber. The refrigerating-chamber C is made of such size as to occupy almost the entire interior of the case, its lining of copper or other suitable metal extending down and under water-chamber F, which latter is the lowest compartment in the case.

B' indicates the ice-chamber, access to which is had by way of cover B, and which is adapted to be packed with ice and contains the coils or coolers D, of any desired style, said coils being connected to any desired number of water-faucets—such as H—and to soda or mineral fountains in the cellar or other suitable locality by means of conducting-pipes a and b, respectively, the connections being made in usual manner.

D' indicates the can chamber or chambers, which are equal in number to the number of sirup-cans employed, or which may be of sufficient size to contain any desired number of cans, and access to which is had through doors R, hinged to front of case.

F is the water chamber or receptacle, which is located directly beneath the can chamber or chambers, the upper wall of which forms the bottom of said can-chambers, and which is connected to the bottom of ice-chamber B' by means of stand-pipe c, through which latter water resulting from melted ice flows, the arrangement of drain-pipe d being such as to cause said water-chamber to stand nearly full at all times. This is accomplished by reason of the end of pipe d projecting upward within the water-chamber a considerable distance above its bottom, as clearly shown in Fig. 1. Thus, it will be observed, the entire sirup-can and its attached measuring-faucet are located in the can-chamber between the ice-chamber above and the ice-water chamber below, enabling sirup to be drawn very cold direct into the glass. The sirup-can G, of which any desired number may be employed, and therefore of which I do not deem it necessary to speak in plural, is preferably made of glass, with a suitable opening in its upper side closed by removable cover G', provided with suitable handle 2 on its front end, by means of which it can be pulled out of the can-chamber, and having casing J' of faucet J cast upon the same end that handle 2 is located upon; or the body of the can may be made of tin or suitable metal, and the entire faucet of brass, with its exposed surfaces lined with tin; or, further, a portion of said faucet could be made of hard rubber, as may be preferred. The inner end of casing J' is covered by a plate O, which forms the inner end of same, and which plate is provided with a central opening 4, through which passes threaded pin 6 on plug I, and with several smaller apertures 5, through which egress of sirup to the faucet is had.

I is a circular plate corresponding in diameter to the inner end of the plug, provided with apertures 7, located on either side of central pin-opening 8, also formed therein, and provided with oppositely-located lugs h, which latter project at right angles from the

inner face of said plate, and which lugs engage corresponding slots or recesses *i*, formed at the inner end of the casing *J'*, upon the interior thereof, for the purpose of holding said plate from turning with said plug, yet at the same time permitting the plug to work loosely in its casing and be adjusted farther in or out to make a tight joint, which is the object of this construction. A small chamber 40 is thus formed between the plate *L* and plate *O*, into which the sirup flows before passing into the main measuring-chamber of plug *I*, said sirup flowing through apertures 7 in said plate *L* and apertures 9 in inner end of the plug, which two series of apertures register when the plug is to be filled.

Casing *J'* is provided with upper and lower and oppositely-located vent and discharge holes *f* and *f'*, respectively, while plug *I*, which is located within said casing, is provided with corresponding upper and lower vent and discharge holes *g* and *g'*, respectively, which latter register with the holes *f* and *f'*, formed in the casing *J'*. The operation of this construction is as follows: When sirup is to be drawn, plug *I* is turned until apertures 9 in its end register with apertures 7 in plate *L*, and allowed to remain in such position until the plug has filled, when it is turned one-quarter of a revolution until discharge-apertures *g'* and *f'* register, discharging the contained measure of sirup into the glass located beneath in recess *A'*. A suitably-sized aperture *e* is made in top of recess *A'* to permit the falling sirup to drop into the glass. The sirup-faucets being located within the refrigerating-chamber, it is obvious that some provision must be made for operating them from without, which is done by journaling suitable handles or keys *P* in the doors *R* and connecting their inner ends to the thumb-pieces or handles 12, formed on outer end of plug *I*. This may be done in various ways; but I prefer to hinge the doors to the case *A* at their lower ends by means of hinge *t*, so that said doors may open downwardly and out, as shown in Fig. 1. The inner ends of handles *P* are preferably bifurcated or provided with a suitable slot, which engages the end 12 of the plug *I*, readily allowing the door to be opened when required, the slotted or forked end of the key being detached from

the plug by the operation of opening the door. The different parts of the faucet *J*, which engage each other, are held in proper adjustment by means of suitable springs, so that all leakage from loose adjustment will be entirely prevented.

M indicates a coiled spring, which is located on pin 6 of the plug, between plates *L* and *O*, the function of which is to urge plate *L* against the inner end of plug *I*, thereby forming at all times a perfect joint therewith, while *N* is a coiled or other suitable form of spring located between plate *O* and nut 10, which latter is threaded upon the inner end of said pin. By properly adjusting nut 10 the two springs will be compressed sufficiently to hold the parts in relative adjustment and all leaks will be avoided. This is clearly shown in Fig. 3.

I do not in this application claim the specific form of the faucet, as I have claimed it in a separate application, filed August 10, 1889, Serial No. 320,410.

Having thus described my invention, what I claim is—

1. In a soda-water dispensing apparatus, the outer case having arranged within the ice-chamber at its top a chamber having an open end and which contains the sirup-cans immediately beneath such ice-chamber, and an ice-water chamber arranged immediately beneath such chamber which contains the sirup-cans, having a permanent cover which closes its upper end and supports said cans, and connected with the ice-chamber by a suitable drain-pipe, substantially as herein set forth.

2. The combination of the outer case provided with a recess for containing glasses, drop-doors hinged to said case above said recess and having journaled therein keys or handles for operating the sirup-faucets, and laterally-movable sirup-cans and attached faucets located entirely within the case, for the purpose substantially as herein set forth.

In testimony whereof I affix my signature in presence of two witnesses.

THEODORE I. WITTING.

Witnesses:

J. A. TERRY,
J. C. HIGDON.