



(12) **EUROPEAN PATENT APPLICATION**
 published in accordance with Art. 153(4) EPC

(43) Date of publication:
20.06.2018 Bulletin 2018/25

(51) Int Cl.:
B65D 47/04 (2006.01) B65D 47/26 (2006.01)

(21) Application number: **16834703.7**

(86) International application number:
PCT/ES2016/070029

(22) Date of filing: **21.01.2016**

(87) International publication number:
WO 2017/025651 (16.02.2017 Gazette 2017/07)

(84) Designated Contracting States:
AL AT BE BG CH CY CZ DE DK EE ES FI FR GB GR HR HU IE IS IT LI LT LU LV MC MK MT NL NO PL PT RO RS SE SI SK SM TR
 Designated Extension States:
BA ME
 Designated Validation States:
MA MD

(71) Applicant: **Bericap Holding GmbH**
55257 Budenheim (DE)
 (72) Inventor: **BADIA INIESTA, Antonio**
08430 La Roca del Valles (Barcelona) (ES)
 (74) Representative: **WSL Patentanwälte Partnerschaft mbB**
Kaiser-Friedrich-Ring 98
65185 Wiesbaden (DE)

(30) Priority: **11.08.2015 ES 201531193**

(54) **CLOSING CAP FOR CONTAINERS FOR LIQUIDS, WITH DISCHARGE ADJUSTMENT**

(57) The invention relates to a closure for containers for liquids, with discharge adjustment, said closure comprising three bodies, a lower body, an intermediate body and an upper body, which are independently moulded and pressed together, characterised in that the lower body comprises means for joining to the neck of the container, windows arranged in a fixed position for the passage of the liquid, means for joining to the upper body, and means for joining to the intermediate body, said in-

termediate body comprising a detachable safety membrane, and conical-radial projections extending below said membrane and in the opposite direction to that of the outflow of the liquid, cooperating with the fixed windows in order to regulate the flow quantity, said projections being deformable and not joined at the centre thereof, the intermediate body being able to turn in relation to the lower body, and said upper body comprising a detachable strip that seals a cover.

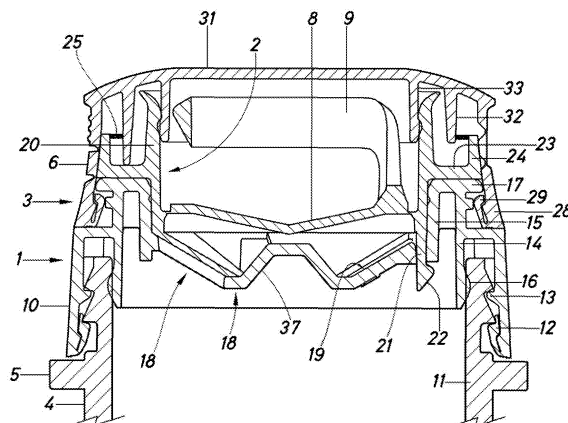

Fig.5

Description

[0001] The present invention relates to a closure designed for closing containers for liquids, which offers characteristic advantages over that which is currently known in the prior art, including those of simple, effective means for adjusting the flow of the liquid poured.

[0002] The closure that is the subject of the present invention is of the general type used on receptacles for liquids, in particular food liquids such as oils and the like, and which have, in general, sealing means for preventing the outflow of liquid toward the exterior, closure means capable of being opened, for pouring, usually in the form of closeable caps and securing means that have to be destroyed or torn prior to commencing the first pouring of the liquid contents, customarily in the form of a tear-off membrane.

[0003] Many types of closures for containers for liquids are known in practice, which attempt to achieve the aforesaid basic features, taking account of the significant issues of cost, ease of mounting on the container, satisfactory closure, and the like.

[0004] The applicant's long experience in the design, manufacture and marketing of closures of the type mentioned has enabled it to develop the new closure that is the subject of the present invention, which is characterized in that it achieves, with a limited number of constituent elements of reduced weight, excellent features of sealed closure of the various zones of the closure and, also, the possibility of varying the flow poured by means that are very simple to use, all the aforesaid combined with very practical means of mounting and sealing.

[0005] The applicant is unaware of embodiments of closures of the type to which the invention relates that include the features defined and claimed.

[0006] The closure that is the subject of the present invention comprises three principle pieces: a lower body for fixing to the container and supporting and fixing the other two bodies of the device, having, in addition, fixed-position windows for the outflow of the liquid, an intermediate body coupled on the lower body and carrying variable-position apertures for the outflow of the liquid between conico-radial protuberances, a security membrane and pouring throat and a third body, or upper body, coupled on the lower body and which has the hinged closure cap and the detachable external seal band.

[0007] The lower body has, at the bottom, an external skirt for coupling and locking on the exterior of the throat of the container, a second, coaxial internal skirt parallel to the exterior skirt and carrying means for sealed closure for the liquid, said lower body further having a third, internal skirt parallel to the first two skirts and designed to be a stop for centering and securing the intermediate body. Furthermore, the lower body has a wall provided with fixed-position windows for the outflow of the liquid.

[0008] The intermediate body is engaged by means of fixing tabs on the lower body and said intermediate body has conico-radial protuberances that are not connected

together at a central point, said conico-radial protuberances leaving apertures for the passage of the liquid therebetween. Said protuberances may coincide in a variable manner on the apertures or windows of radial form of the lower body, having, furthermore, an intermediate security membrane with detachment pull-ring and an upper pouring neck. The intermediate body can turn about its central axis, which coincides with the central axis of the closure, in order to achieve variable matching of its outflow openings or windows with those of the lower body, varying the quantity of flow poured.

[0009] The upper body is coupled or snap-fitted by means of an internal retention band onto the lower body and has the cap of the closure which is hinged, which engages with the pouring throat of the intermediate body and, furthermore, said upper body has the detachable band that forms the external seal and allows the opening of the hinged cap.

[0010] More particularly, the present invention comprises a closure for containers for liquids with adjustment of the flow poured, said closure being formed by three bodies, a lower body, an intermediate body, and an upper body, which are molded independently and press-engaged together, characterized in that the lower body comprises means for connection to the throat of the container, fixed-position windows for the passage of the liquid, means for connection to the upper body, and means for connection to the intermediate body, said intermediate body comprising a detachable security membrane, there projecting under said membrane and in the opposite direction to the outflow direction of the liquid conico-radial protuberances that collaborate with the fixed windows in order to regulate the flow quantity, said protuberances being deformable and not connected at their middle point, the intermediate body having the capacity to turn with respect to the lower body and said upper body comprising a detachable band that secures a cap.

[0011] Preferably, the intermediate body has an intermediate flange facing outward, which, once the intermediate body has been mounted, abuts against the lower body, and which has a peripheral ring with non-slip reliefs to allow said turn manually.

[0012] Preferably, the means for connecting the intermediate body to the lower body comprise a central cylindrical part of the intermediate body that is press-coupled on the internal part of a skirt of the lower body and has retention tabs with retention ribs on the lower edge of said cylindrical part that are inserted in holes in the form of a circular arc shaped groove in the lower body, preventing axial exit displacement of the intermediate body and also marking a stop in the turn of the intermediate body with respect to the lower body.

[0013] Preferably, the means for connection of the intermediate body to the lower body comprise a flexible band for engagement on the lower body which is folded by entering into contact with a projection of the intermediate body, preventing the axial exit displacement of the intermediate body.

[0014] Preferably, the intermediate body has on the upper edge of its cylindrical part, a fin curved toward the exterior for the pouring of the liquid.

[0015] Preferably, the intermediate body has, in the interior of its cylindrical part, the detachable security membrane carrying an extraction pull-ring, acting as security seal, which can be extracted by means of tearing by pulling on said extraction pull-ring once the cap of the closure has been raised.

[0016] Preferably, the lower body comprises two substantially cylindrical and coaxial skirts that are coupled to the throat of the container.

[0017] Preferably, in addition to said two skirts, the lower body has an internal skirt designed for centering and retention of the intermediate body, the two innermost skirts being connected together at the closure by a planar zone designed to receive the intermediate body of the closure in abutment.

[0018] Preferably, in addition to said two skirts, the lower body has an interior projection designed for centering and retention of the intermediate body, said projection being connected by its lower part to the innermost skirt and said innermost skirt having a planar zone designed to receive the intermediate body of the closure in abutment.

[0019] Preferably, in addition to the aforesaid two skirts of the lower body, the top part of the internal skirt is designed for centering and retention of the intermediate body, which is designed for receiving a flexible band of the intermediate body.

[0020] Preferably, the means for connection of the lower body to the throat of the container comprise a lower flexible band incorporated internally in the lower part of the external skirt of said lower body, said lower flexible band establishing contact with a relief of the throat, and an internal rib of said external skirt that establishes contact with a second relief of the throat of the container.

[0021] Preferably, the receiving means of the upper body comprise a lower annular zone carrying a flexible retention band that is retained by the lower body.

[0022] Preferably, said detachable band extends via the periphery of said upper body, leaving the intermediate body visible when said band is detached.

[0023] Preferably, the intermediate body is in a different color from the lower body and the upper body.

[0024] Preferably, the cap of the upper body has, internally, two concentric cylindrical projections: one with a sealing rib that engages with the cylindrical part of the intermediate body, and another that coincides on the intermediate flange of the intermediate body.

[0025] Preferably, the cap of the upper body is connected to the upper body by means of a hinge.

[0026] For a better understanding of the invention, drawings representing two embodiments of the closure that is the subject of the present invention are attached by way of explanatory but non-limiting example.

Figure 1 shows a perspective view of a closure ac-

ording to the present invention.

Figure 2 shows a perspective view of a closure, according to the invention, showing the detachable band that forms the external seal after it has been removed.

Figure 3 shows a perspective view of the hinged cap in the open position.

Figure 4 shows a perspective of the closure of figures 1 to 3, in a view that makes it possible to observe the interior of the open closure, in which the security membrane has been torn off together with its extraction pull-ring.

Figure 5 shows a full cross section of a closure embodied in accordance with the present invention.

Figure 6 shows the lower body of the closure that is the subject of the present invention, partially in section.

Figure 7 shows a perspective view of the lower body of the closure that is the subject of the invention.

Figure 8 shows a perspective view of the intermediate body of the closure that is the subject of the invention, partially in section.

Figure 9 shows a perspective view of the intermediate body of the closure that is the subject of the invention.

Figure 10 shows a perspective view of the upper body of the closure that is the subject of the invention, partially in section.

Figure 11 shows a cross section of the aforesaid separate three bodies in a second embodiment.

Figure 12 shows a full cross section of a closure embodied in accordance with the present invention in a second embodiment.

Figure 13 shows a cross section of the aforesaid separate three bodies in a third embodiment.

Figure 14 shows a full cross section of a closure embodied in accordance with the present invention in a third embodiment.

Figure 15 shows a cross section of the aforesaid separate three bodies in a fourth embodiment.

Figure 16 shows a full cross section of a closure embodied in accordance with the present invention in a fourth embodiment.

[0027] Figure 1 shows the exterior appearance of the closure applied onto the end of a container -4- provided with a flange -5- on the throat. Said figure shows the lower body -1- and the upper body -3- of the closure that is the subject of the invention.

[0028] Figure 2 shows the same elements as figure 1, showing, removed, the detachable band -6- that forms the external seal of the closure and has the part of the non-slip peripheral ring of the intermediate body -2-. The intermediate body -2- is manufactured in a different color from the upper body -3- and lower body -1- so that the user is able rapidly to see that the detachable band -6- has been torn off, by observing the difference in color between the bodies.

[0029] Figure 3 shows the same elements as figure 2, showing a hinged cap -31- opened by means of the hinging fin -35-, allowing part of the intermediate body -2- to be seen.

[0030] Figure 4 shows the same elements as figure 3, showing the security membrane -8- with its manual extraction pull-ring -9- removed, which makes it possible to observe part of the internal arrangement of the intermediate body -2- .

[0031] Figure 5 shows structural elements of the closure that is the subject of the present invention in the mounted position, in a first embodiment. It should be noted that the closure has been shown incorporated into the upper throat of a container designed to contain a liquid, for example a liquid for consumption, such as oil, of which an upper part -4- and the flange -5-, which evidently do not form part of the present invention, have been shown.

[0032] As may be seen in figure 6, the lower body -1- has a substantially cylindrical external skirt -10- designed to be coupled onto the exterior part of the throat -11- of the receptacle (see figure 5). For securing the body -1- onto the throat -11- of the container, said lower body -1- has a lower flexible band -12- in the form of an interior fin folded inward and upward, with elastic characteristics, which once inserted catches on a relief of the upper part of the throat -11- for the purposes of the axial retention thereof.

[0033] Said lower body -1- has, in the interior of its external skirt -10-, a rib -13- of fixed type, but with elastic characteristics, which is retained in a manner similar to the lower flexible band -12-, on a relief of the throat -11-, as may be seen in figure 5. Therefore, the axial fixing of the lower body -1- with respect to the container will be assured by the combined retention action of said lower flexible band -12- and rib -13- with the external reliefs of the throat -11-.

[0034] Internally, the lower body -1- has, in a first embodiment, a further two substantially cylindrical internal skirts -14- and -15- coaxial with the external skirt -10-, which may be seen in figures 5 and 6. The internal skirt -14- is coupled to the interior of the throat -11- of the container and has a broad lower rib -16- for assuring the sealed connection of the lower body of the closure onto the container.

[0035] In a first embodiment, the other internal skirt -15- is designed to receive the corresponding part of the intermediate body -2- and via its upper part it is connected by means of the planar zone -17- to the intermediate skirt -14-, providing an abutment zone for the intermediate body -2- as will be explained below. In a first embodiment, the lower body -1- of the example has, internally, a conico-radial surface -18- provided with a central projection -37- and three radial windows -19- and three holes -39- in the form of a circular arc, as shown in figure 7. Said windows -19- have a substantially conico-radial arrangement and are designed to allow the outflow of the liquid contained in the receptacle onto which the closure is applied, combining with the action of turning the intermediate body in order to adjust the flow poured by the closure that is the subject of the invention when the container is emptied.

[0036] In a first embodiment, the intermediate body -2- is shown in detail in figure 5, which shows a full section through the closure, and in figures 8 and 9, which show a perspective view in section and in full of said intermediate body -2-. As may be seen, said intermediate body has a cylindrical part -20- that engages onto the lower edge of the skirt -15- of the lower body -1-, being retained thereon by means of the fixing tabs -21- provided with a projecting retention rib -22- that is engaged through the holes -39- in the lower edge of the skirt -15-, preventing, after its insertion based on elasticity, the axial exit of said intermediate body -2-; the various elements can be seen in figures 6 and 7. As may be observed, the holes -39- have the form of a circular arc shaped groove. It is possible for the fixing tabs -21- to slide along said holes, thereby allowing the turning of the intermediate body -2- with respect to the lower body -1-, the holes -39- marking the turning stop of the intermediate body -2- with respect to the lower body -1-. Said intermediate body has a security membrane -8- and an extraction pull-ring -9- that make up the internal seal that has to be opened by means of tearing after opening of the closure cap, in order to allow the contents of the container to flow out.

[0037] The cylindrical part -20- of the intermediate body has a broad intermediate flange -23- that, once mounted, coincides on the planar zone -17- of the lower body, thereby abutting thereon when the intermediate body is press-inserted into the lower body. Said intermediate flange -23- has a peripheral ring -24- provided with non-slip reliefs -25- to make it possible manually to turn the intermediate body -2- on the lower body. Conico-radial protuberances -26- face radially away from the cylindrical part -20- toward the interior of the intermediate body. Said conico-radial protuberances -26- delimit openings -38- therebetween and have an inclined form corresponding with the windows -19- and the conico-radial surface -18- of the lower body -1-. Furthermore, as may be seen in figures 8 and 9, said conico-radial protuberances -26- are not connected together at their middle point, thereby allowing the engagement with the central projection -37- of the lower body. Depending on the po-

sition of turning of the intermediate body, the degree of closing-off of said windows of the lower body is varied. Thus, it is very easy to adjust the quantity of flow poured by the closure that is the subject of the invention.

[0038] The intermediate body -2- ends in the cylindrical part -20- thereof, in a peripheral fin -27-, which is slightly curved toward the exterior, to allow pouring of the liquid contained in the container.

[0039] The upper body -3- shown in figure 10 has a lower annular zone -28- provided, internally, with a flexible retention band -29- similar to the above-described lower flexible band -12- of the lower body -1-, which is designed to be retained inside the intermediate body, as it is possible to see in figure 5. Above said annular part -28- there is the detachable band -6- from which continues the lateral surface -30- of the hinged cap -31-, which is hinged to the annular part -28- in the zone where the detachable band -6- does not extend, thereby defining a hinging fin -35- (figures 3 and 4) . Internally, the hinged cap -31- has two internal cylindrical projections -33- and -32-, designed to engage, respectively, with the cylindrical part -20- and the intermediate flange -23- of the intermediate body (figures 5 and 10). Said hinged cap is retained in the intermediate body by means of the flexible retention band -29- and closes in a sealed manner with the aid of an internal rib -34- on the cylindrical part -20- of the intermediate body -2- of the closure that is the subject of the invention.

[0040] Figures 10 and 11 show a second embodiment of the closure of the present invention. This second embodiment has a different fixing system between the lower body -1- and the intermediate body -2-, allowing more robust securing.

[0041] As shown in figures 10 and 11, the lower body -1- has a flexible engagement band -41- that enters into contact with a projection -42- of the intermediate body. In turn, said projection -42- engages by means of dimensional interference with the internal projection -43- of the lower piece.

[0042] Figure 11 shows the flexible engagement band -41-, the flexible retention band -29- and the lower flexible band -12- in their deployed positions. Said bands are folded upon engagement of the various bodies -1-, -2-, -3-, as seen in figure 12, exerting a retention effect.

[0043] In figures 13 and 14, a third embodiment of the closure of the present invention is shown. Said third embodiment represents a fixing system between the lower body -1- and the intermediate body -2-, which allows a more flexible fixing between the upper body -3- and the lower body -1-. Identical or similar elements of the aforesaid embodiments have been designated with identical reference numerals except for the elements which will be explained in the following.

[0044] As shown in figures 13 and 14, the lower body -1- represents a flexible band for modified engagement -47- which enters into contact with a modified projection -46- of the intermediate body. In turn, said modified projection -46- engages by means of dimensional interfer-

ence with the internal projection -43- of the lower piece. As can be seen, the flexible band for modified engagement -47- and the modified projection -46- represent a smaller wall thickness than in the second embodiment of the present invention in order to solve structural problems in the closure to improve the functioning as being the most flexible connection.

[0045] The annular part -28- of the upper body -3- represents in its lower part a ridge -45-, which engages with the combined ridge -44- in the upper part of the external skirt -10- of the lower body -1-. Said engagement improves the rigidity of the connection between the different parts of the body.

[0046] The modified peripheral ring -50- represents a lower diameter with respect to the second embodiment in order to make its function more comfortable for the user.

[0047] In figures 15 and 16, a fourth embodiment of the closure of the present invention is shown. Said fourth embodiment represents a different fixing system between the lower body -1- and the intermediate body -2-, which allows a more flexible fixing. The components are explained in figures 13 and 14 except for the elements which are explained in the following.

[0048] As shown in figures 15 and 16, the lower body -1- represents a flexible band for modified engagement -47- which enters into contact with a modified projection -49- of the intermediate body, which also comprises a new flexible band -48-. As can be seen, said new flexible band -48- engages with the upper part of the inner skirt -51- of the lower piece.

[0049] The explained construction in three bodies of specific features of the closure that is the subject of the invention allows simplified manufacture and mounting of the various elements thereof in a manner that can obviously be automated. Consequently, it will be very easy to mechanize not only the mounting of the complete closures but also the incorporation thereof, simply using pressure, onto the throat of the container to be closed, thereby achieving effective closure features, security against manipulation and easy adjustment of the flow poured, by virtue of the ease with which the intermediate body turns on itself once the exterior seal has been removed from the closure.

[0050] The three components of the closure will be manufactured preferably by means of injection of plastics, it being possible to use different materials, including PET plastics material, which is customarily used for molding containers.

[0051] The specific geometry of the conico-radial protuberances, which can be seen in figures 8 and 9, makes it possible to manufacture the intermediate body by means of injection of plastics and to provide, in a single piece, the intermediate body, the tear-off membrane and the conico-radial protuberances that form part of the flow-quantity regulator. Indeed, said conico-radial protuberances, by not being connected together at their free ends, it is possible to demold same by deforming the conico-

radial protuberances toward the exterior.

[0052] Although the invention has been presented and described with reference to embodiments thereof, it will be understood that these embodiments do not limit the invention, and therefore there could be variable multiple structural details or the like that may be obvious for skilled persons in the sector after interpreting the subject matter that is disclosed in the present description, claims and drawings. Thus, all the variants and equivalents will be included within the scope of the present invention if they can be deemed to have been included within the more extensive scope of the following claims.

Claims

1. A closure for containers for liquids with adjustment of the flow poured, said closure being formed by three bodies, a lower body, an intermediate body, and an upper body, which are molded independently and press-engaged together, **characterized in that** the lower body comprises means for connection to the throat of the container, fixed-position windows for the passage of the liquid, means for connection to the upper body, and means for connection to the intermediate body, said intermediate body comprising a detachable security membrane, there projecting under said membrane and in the opposite direction to the outflow direction of the liquid conico-radial protuberances that collaborate with the fixed windows in order to regulate the flow quantity, said protuberances being deformable and not connected at their middle point, the intermediate body having the capacity to turn with respect to the lower body and said upper body comprising a detachable band that seals a cap.
2. The closure for containers for liquids as claimed in claim 1, **characterized in that** the intermediate body has an intermediate flange facing outward, which, once the intermediate body has been mounted, abuts against the lower body, and which has a peripheral ring with non-slip reliefs to allow said turn manually.
3. The closure for containers for liquids as claimed in claims 1 and 2, **characterized in that** the means for connecting the intermediate body to the lower body comprise a central cylindrical part of the intermediate body that is press-coupled on the internal part of a skirt of the lower body and has retention tabs with retention ribs on the lower edge of said cylindrical part that are inserted in holes in the form of a circular arc shaped groove in the lower body, preventing axial exit displacement of the intermediate body and also marking a stop in the turn of the intermediate body with respect to the lower body.
4. The closure for containers for liquids as claimed in claims 1 and 2, **characterized in that** the means for connection of the intermediate body to the lower body comprise a flexible band for engagement on the lower body which is folded by entering into contact with a projection of the intermediate body, preventing the axial exit displacement of the intermediate body.
5. The closure for containers for liquids as claimed in any of the preceding claims, **characterized in that** the intermediate body has on the upper edge of its cylindrical part, a fin curved toward the exterior for the pouring of the liquid.
6. The closure for containers for liquids as claimed in any of the preceding claims, **characterized in that** the intermediate body has, in the interior of its cylindrical part, the detachable security membrane carrying an extraction pull-ring, acting as security seal, which can be extracted by means of tearing by pulling on said extraction pull-ring once the cap of the closure has been raised.
7. The closure for containers for liquids as claimed in any of the preceding claims, **characterized in that** the lower body comprises two substantially cylindrical and coaxial skirts that are coupled to the throat of the container.
8. The closure for containers for liquids as claimed in claim 7, **characterized in that**, in addition to said two skirts, the lower body has an internal skirt designed for centering and retention of the intermediate body, the two innermost skirts being connected together at the top by a planar zone designed to receive the intermediate body of the closure in abutment.
9. The closure for containers for liquids as claimed in claim 7, **characterized in that**, in addition to said two skirts, the lower body has an interior projection designed for centering and retention of the intermediate body, said projection being connected by its lower part to the innermost skirt and said innermost skirt having a planar zone designed to receive the intermediate body of the closure in abutment.
10. The closure for containers for liquids as claimed in claim 7, **characterized in that** in addition to the aforesaid two skirts of the lower body, the upper part of the internal skirt is designed for centering and retention of the intermediate body, which is designed for receiving a flexible band of the intermediate body.
11. The closure for containers for liquids as claimed in any of the preceding claims, **characterized in that** the means for connection of the lower body to the throat of a container comprise a lower flexible band

incorporated internally in the lower part of the external skirt of said lower body, said lower flexible band establishing contact with a relief of the throat and an internal rib of said external skirt that establishes contact with a second relief of the throat of the container. 5

12. The closure for containers for liquids as claimed in any of the preceding claims, **characterized in that** the receiving means of the upper body comprise a lower annular zone carrying a flexible retention band that is retained by the lower body. 10

13. The closure for containers for liquids as claimed in any of the preceding claims, **characterized in that** said detachable band extends via the periphery of said upper body, leaving the intermediate body visible when said band is detached. 15

14. The closure for containers for liquids as claimed in claim 13, **characterized in that** the intermediate body is in a different color from the lower body and the upper body. 20

15. The closure for containers for liquids as claimed in any of the preceding claims, **characterized in that** the cap of the upper body has, internally, two concentric cylindrical projections: one with a sealing rib that engages with the cylindrical part of the intermediate body, and another that coincides on the intermediate flange of the intermediate body. 25 30

16. The closure for containers for liquids as claimed in any of the preceding claims, **characterized in that** the cap of the upper body is connected to the upper body by means of a hinge. 35

40

45

50

55

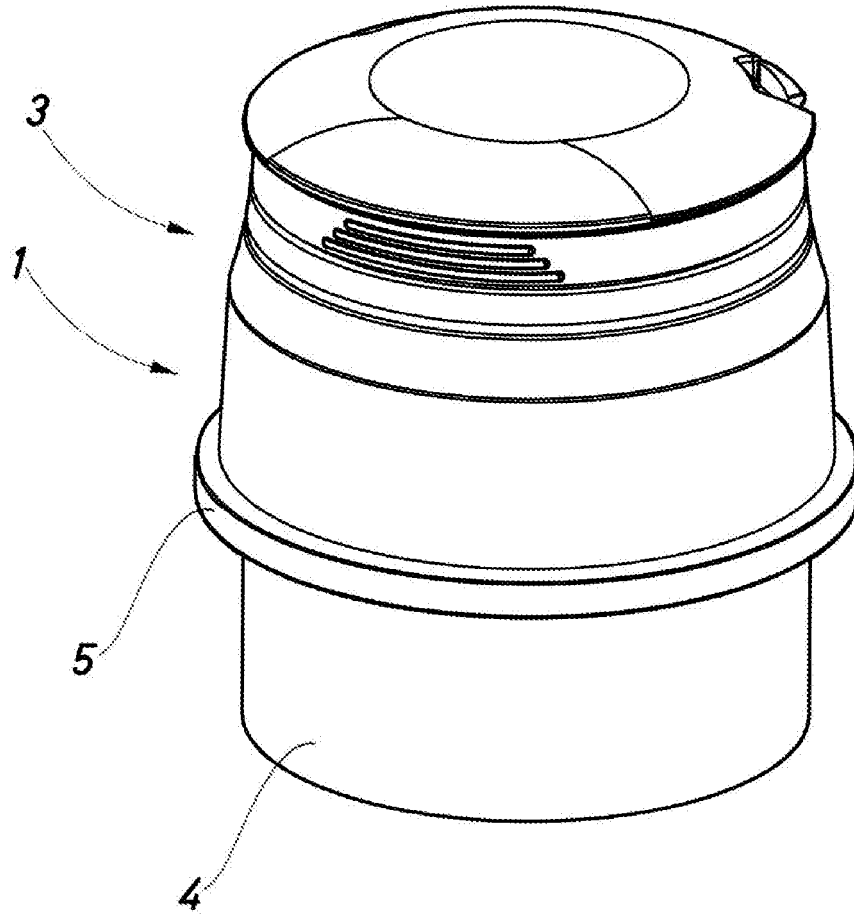

Fig.1

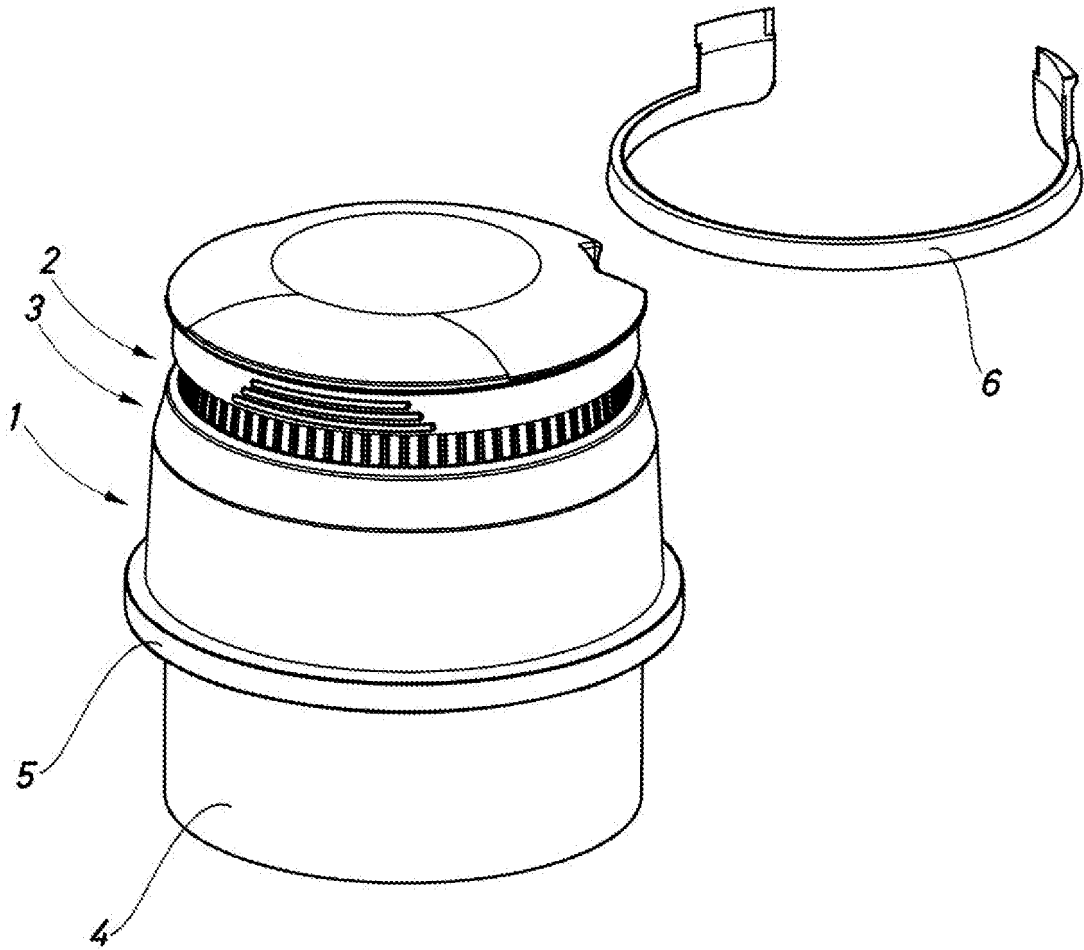

Fig.2

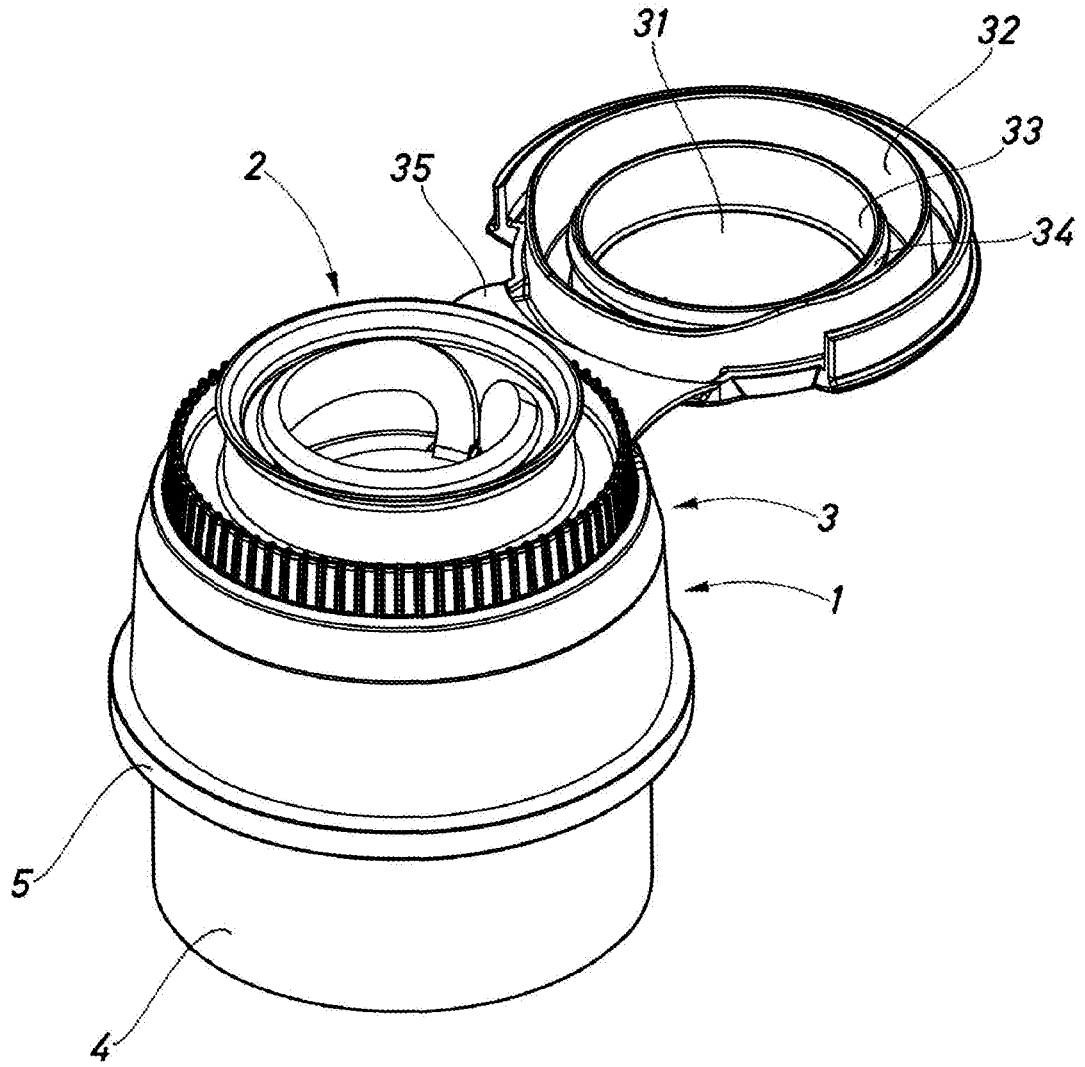

Fig.3

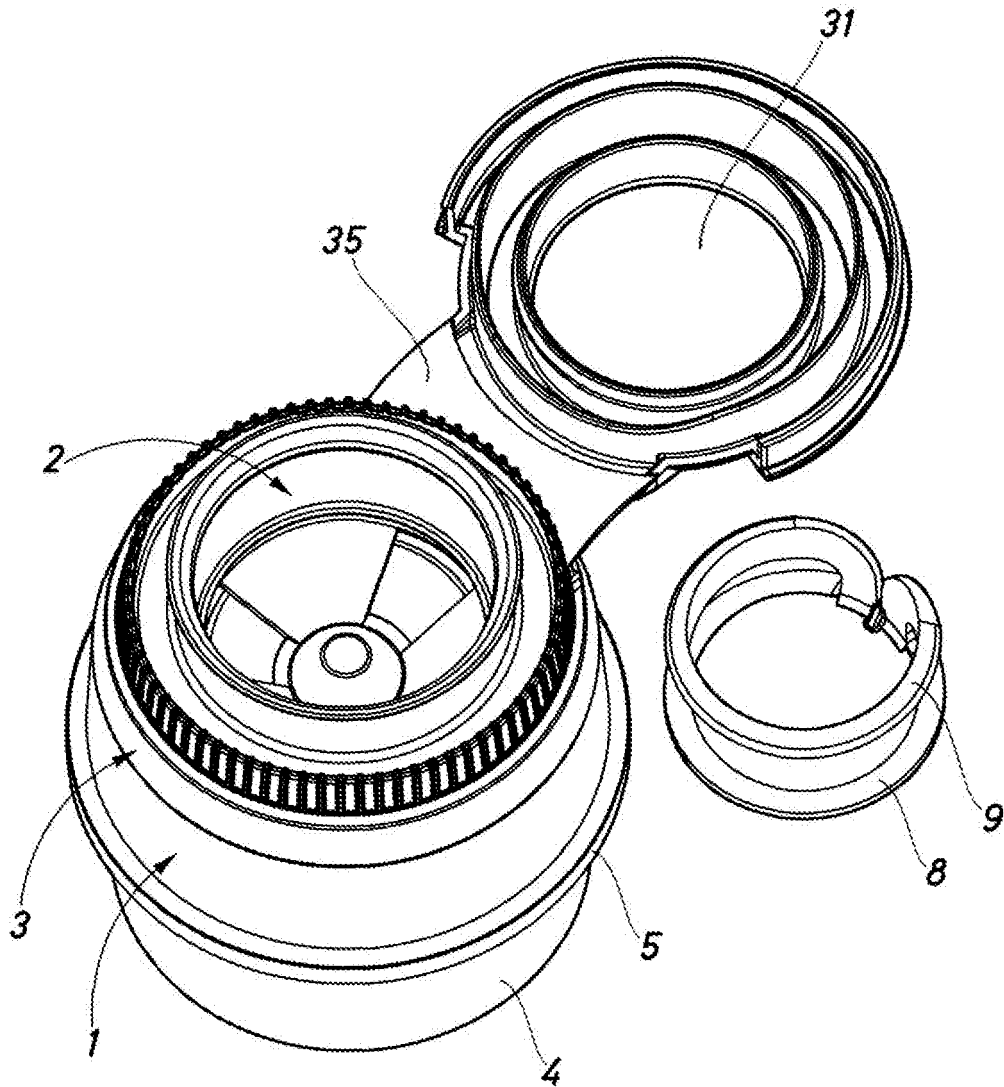

Fig.4

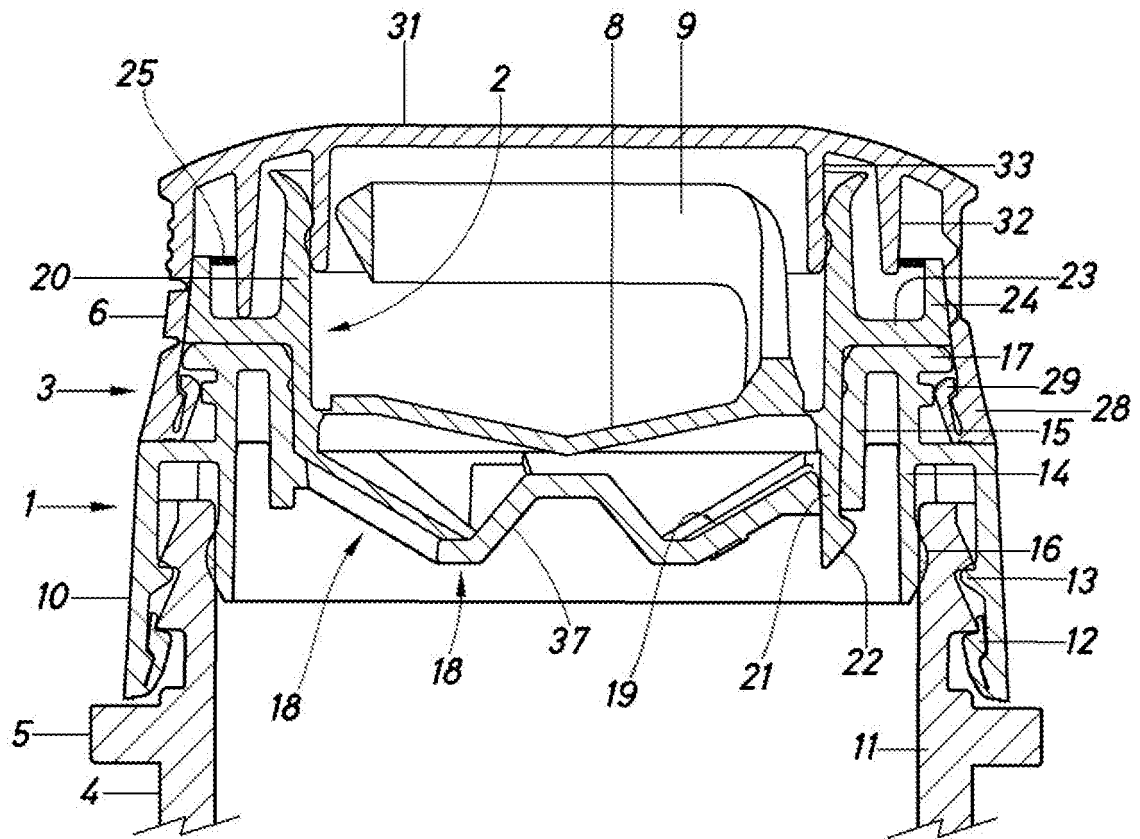

Fig.5

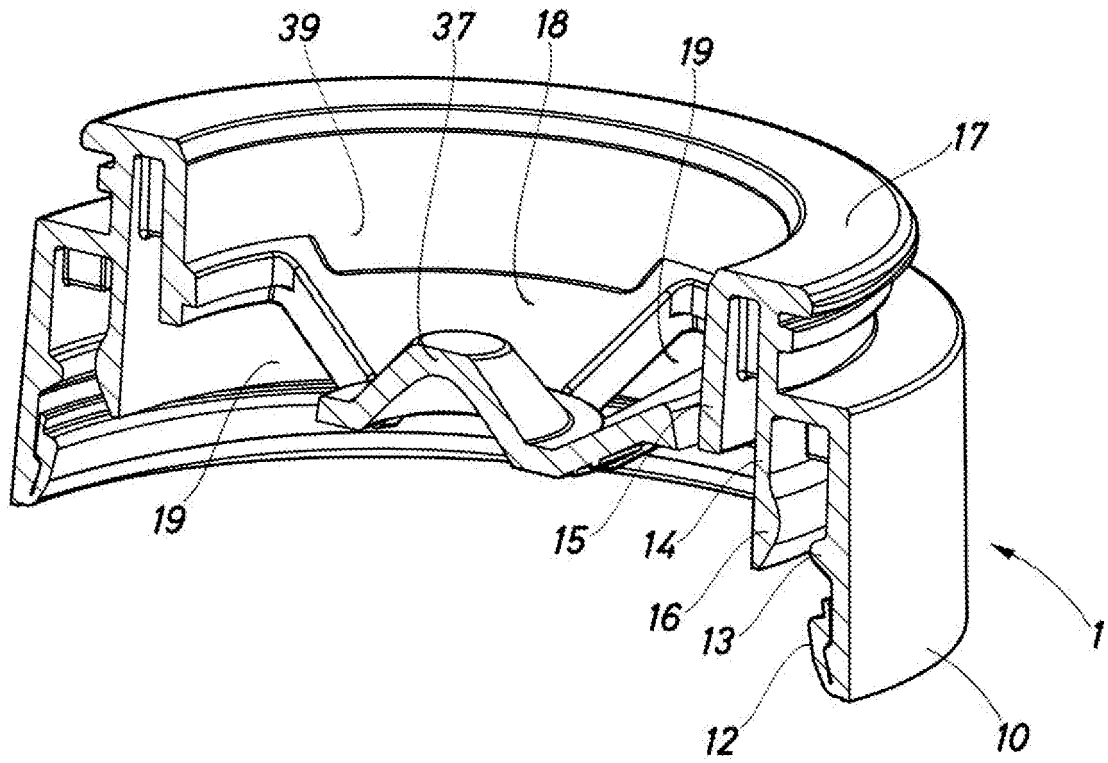

Fig.6

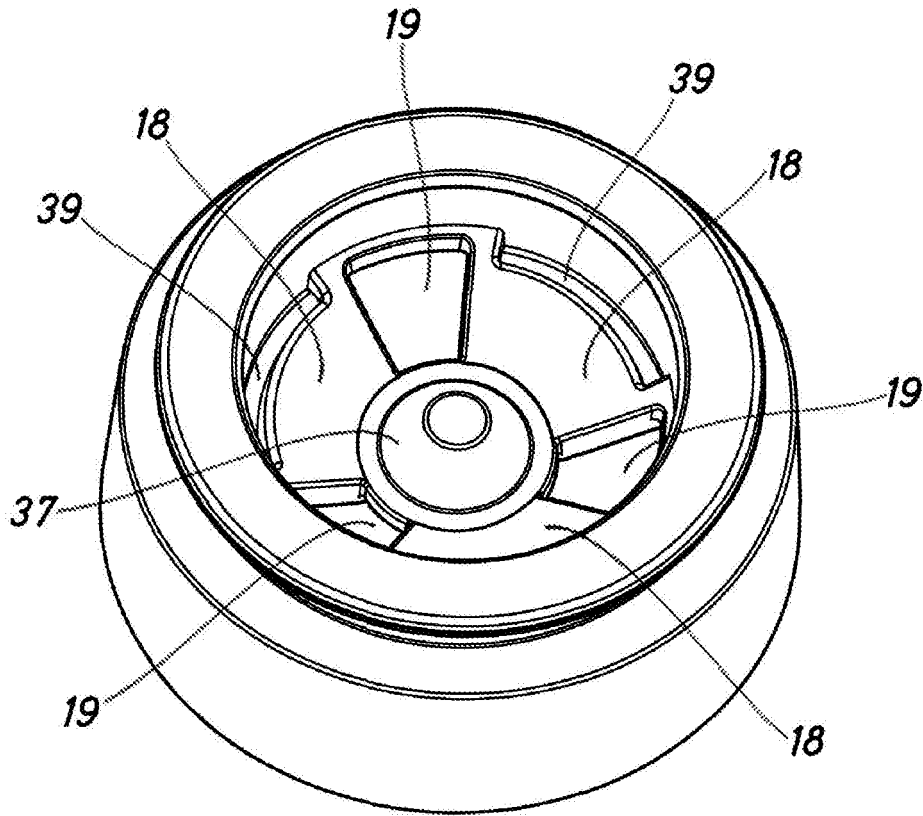

Fig.7

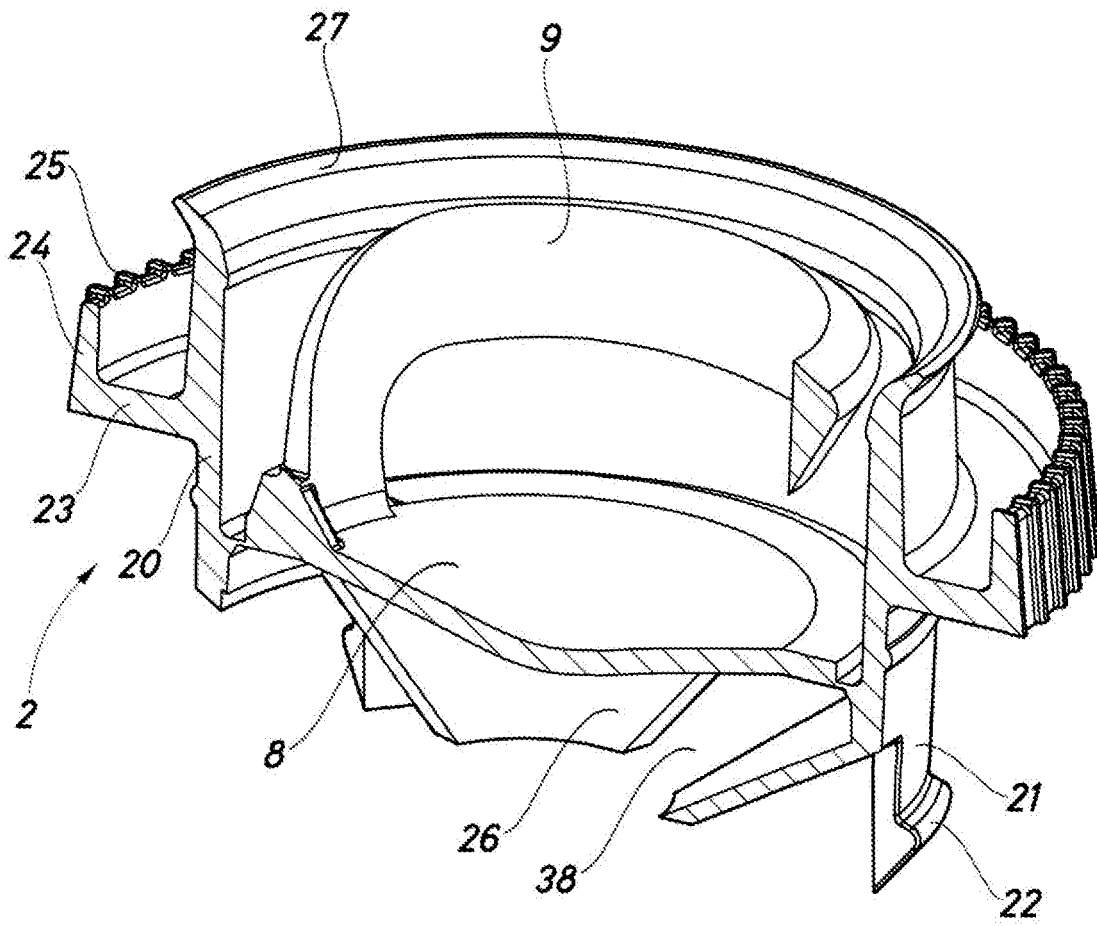

Fig. 8

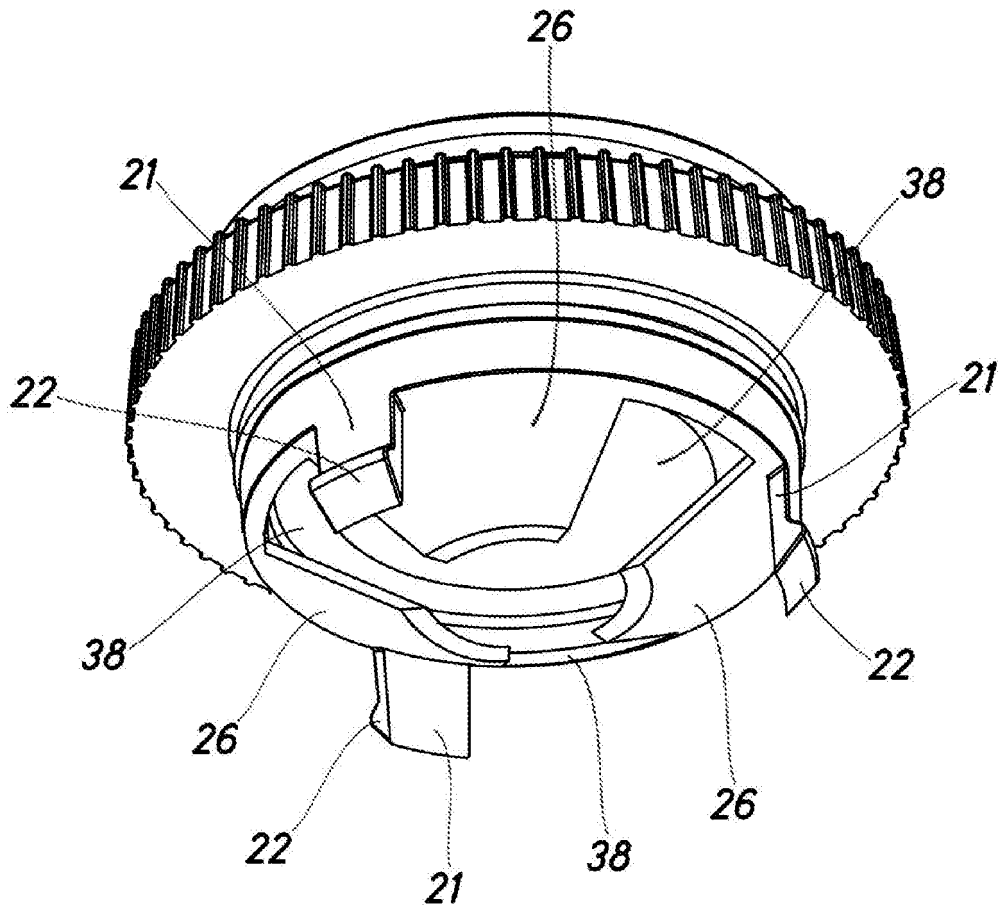

Fig.9

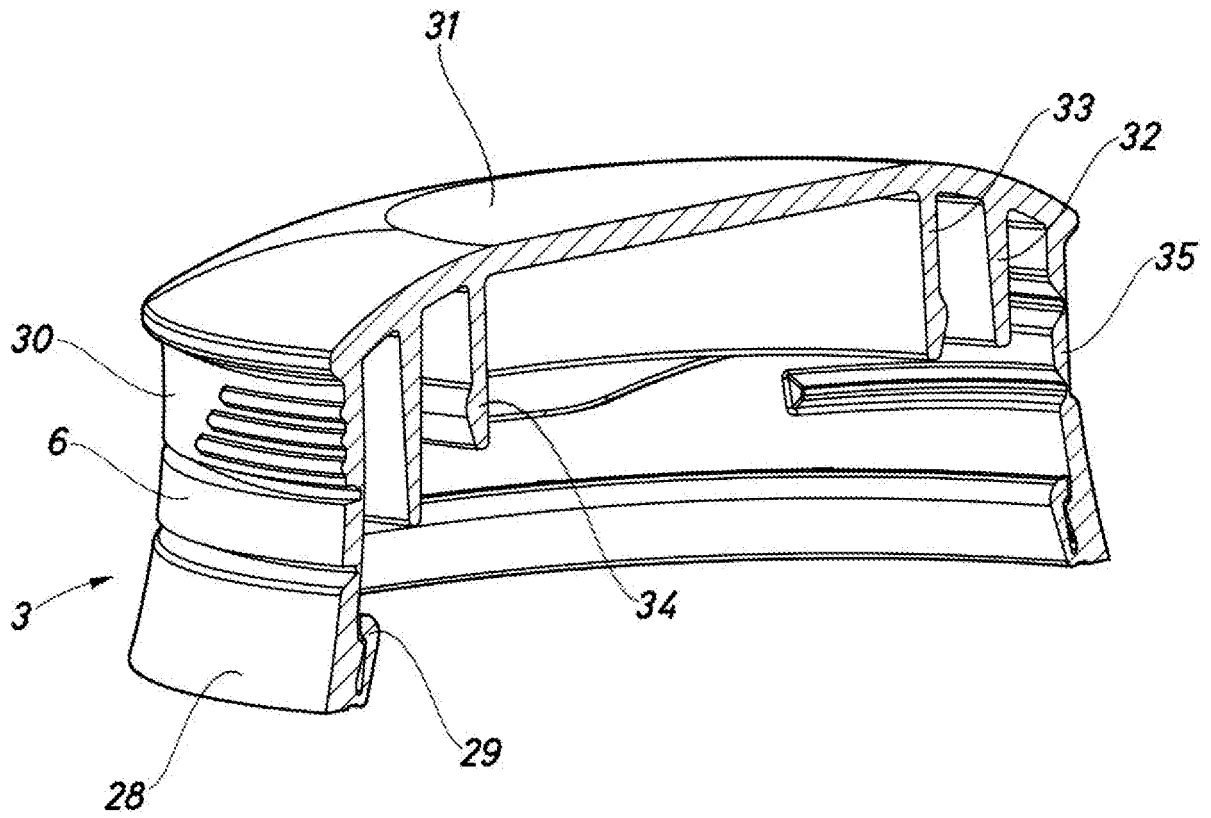

Fig.10

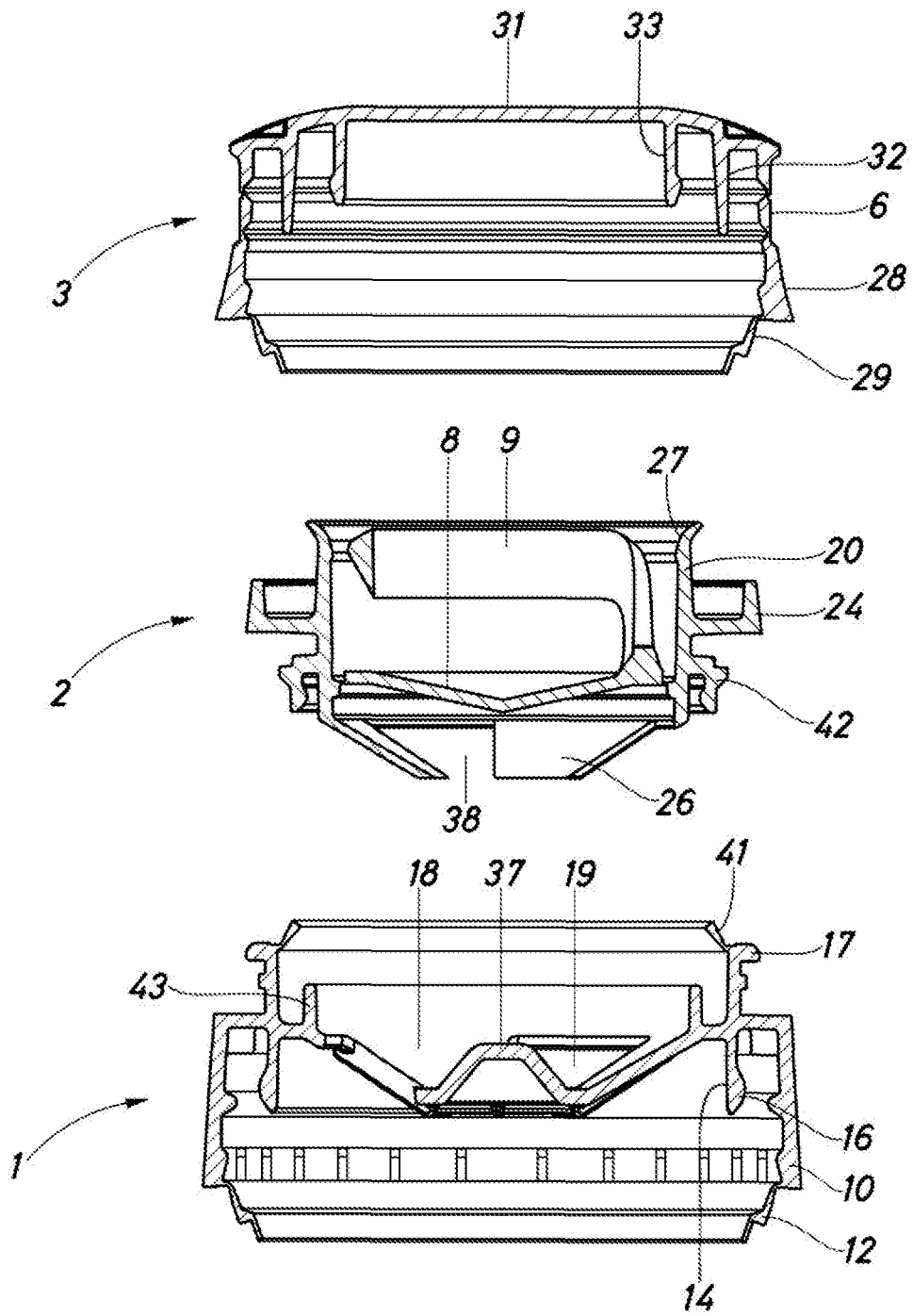

Fig.11

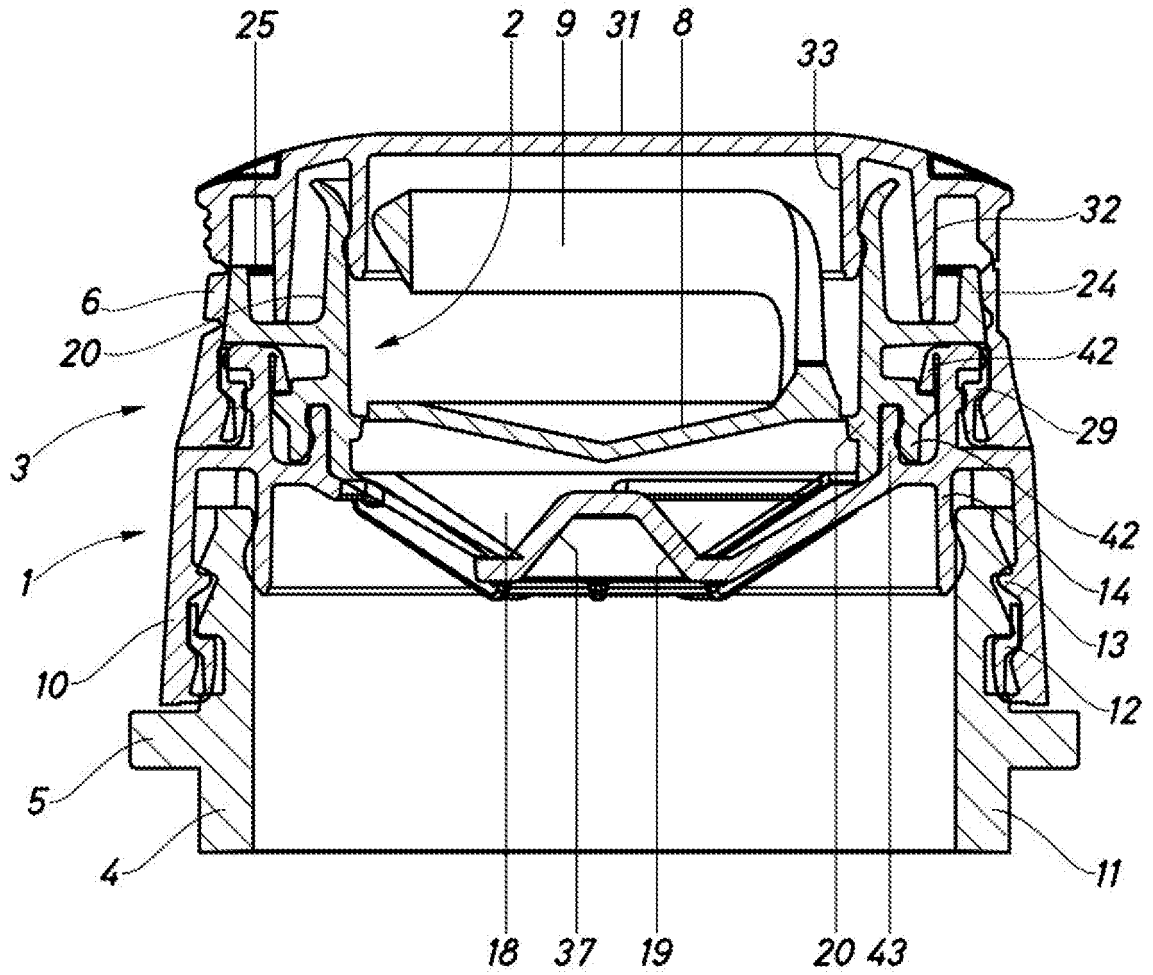

Fig.12

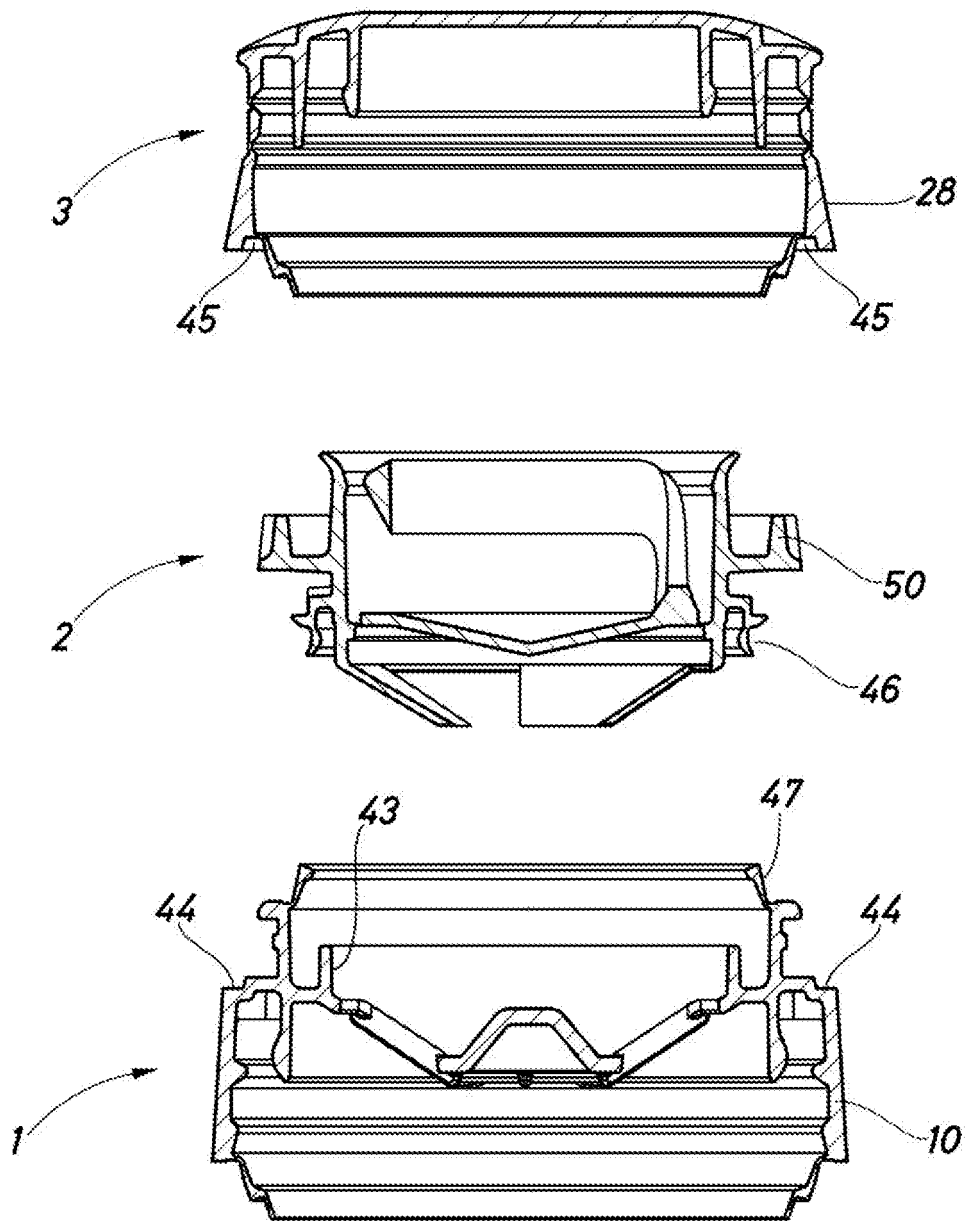

Fig.13

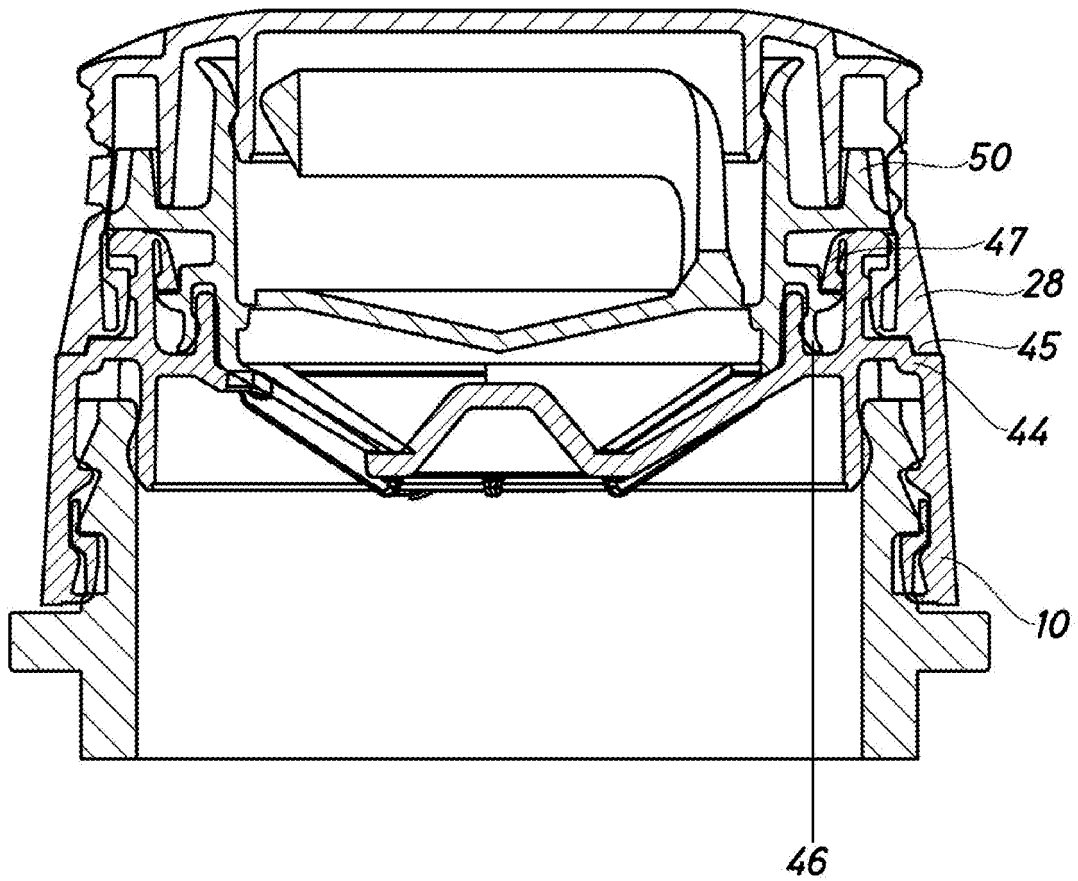

Fig.14

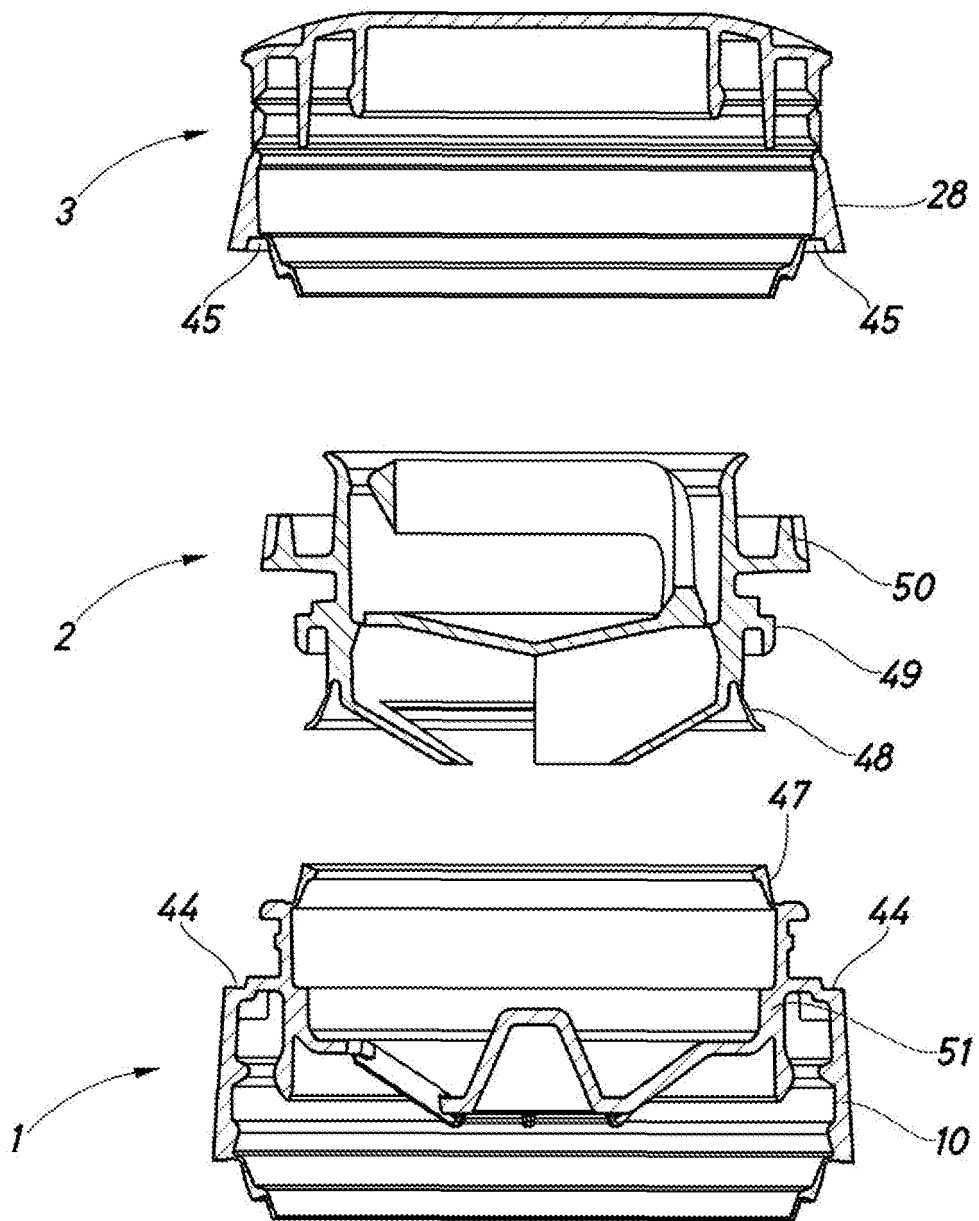

Fig.15

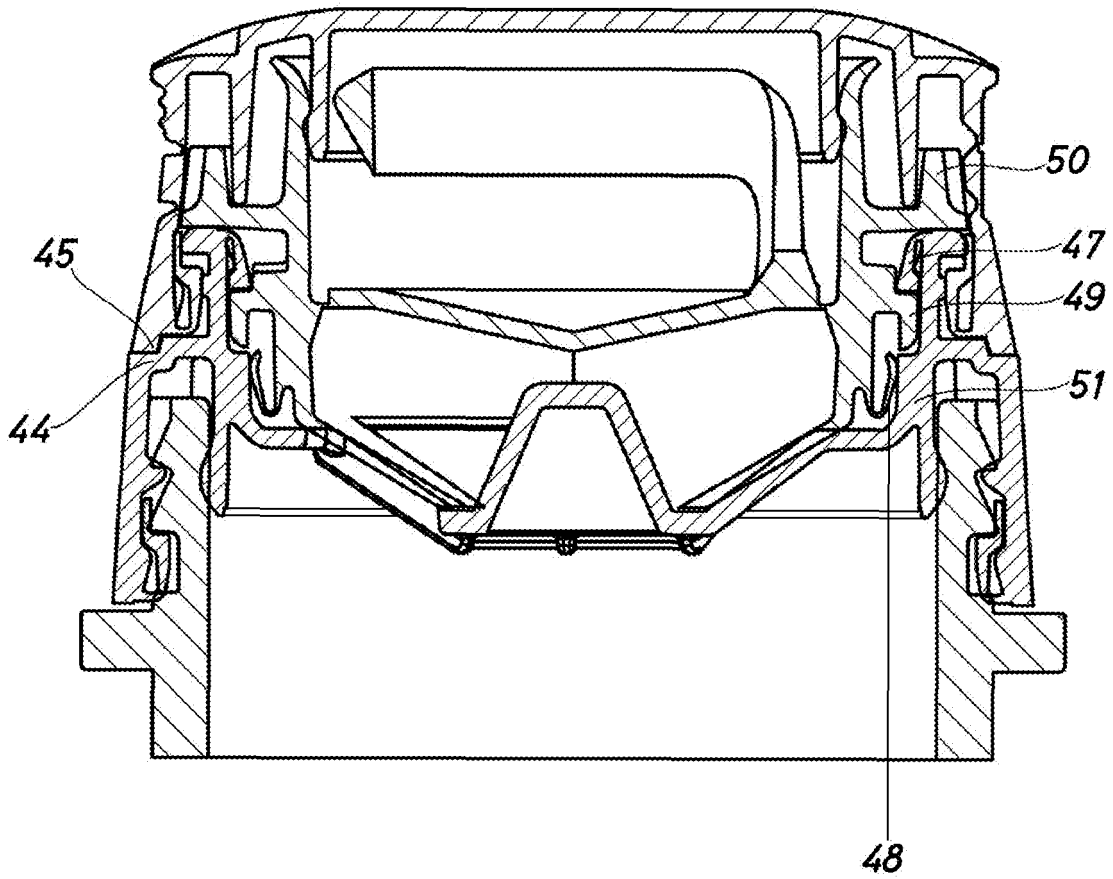

Fig.16

INTERNATIONAL SEARCH REPORT

International application No.

PCT/ES2016/070029

5	A. CLASSIFICATION OF SUBJECT MATTER	
	B65D47/04 (2006.01) B65D47/26 (2006.01) According to International Patent Classification (IPC) or to both national classification and IPC	
10	B. FIELDS SEARCHED	
	Minimum documentation searched (classification system followed by classification symbols) B65D	
	Documentation searched other than minimum documentation to the extent that such documents are included in the fields searched	
15	Electronic data base consulted during the international search (name of data base and, where practicable, search terms used)	
	EPODOC, INVENES	
	C. DOCUMENTS CONSIDERED TO BE RELEVANT	
20	Category*	Citation of document, with indication, where appropriate, of the relevant passages
	A	ES 2230492T T3 (CROWN PACKAGING TECHNOLOGY INC) 01/05/2005, claims and figures.
25	A	ES 2343856T T3 (CAPARTIS AG) 11/08/2010, Page 5 line 58 a page 6 line 22.
	A	DE 19840858 A1 (ARTEC GMBH ENTWICKLUNGS UND KO) 16/03/2000, Abstract and figures 1 and 2.
30	A	ES 1078137U U (BETAPACK SA) 28/11/2012, claims and figures.
	A	FR 2900909 A1 (BERICAP SARL) 16/11/2007, Abstract and figures.
35		
40	<input type="checkbox"/> Further documents are listed in the continuation of Box C. <input checked="" type="checkbox"/> See patent family annex.	
45	* Special categories of cited documents:	"T" later document published after the international filing date or priority date and not in conflict with the application but cited to understand the principle or theory underlying the invention
	"A" document defining the general state of the art which is not considered to be of particular relevance.	"X" document of particular relevance; the claimed invention cannot be considered novel or cannot be considered to involve an inventive step when the document is taken alone
	"E" earlier document but published on or after the international filing date	"Y" document of particular relevance; the claimed invention cannot be considered to involve an inventive step when the document is combined with one or more other documents, such combination being obvious to a person skilled in the art
50	"L" document which may throw doubts on priority claim(s) or which is cited to establish the publication date of another citation or other special reason (as specified)	"&" document member of the same patent family
	"O" document referring to an oral disclosure use, exhibition, or other means.	
	"P" document published prior to the international filing date but later than the priority date claimed	
	Date of the actual completion of the international search 07/03/2016	Date of mailing of the international search report (08.03.2016)
55	Name and mailing address of the ISA/ OFICINA ESPAÑOLA DE PATENTES Y MARCAS Paseo de la Castellana, 75 - 28071 Madrid (España) Facsimile No.: 91 349 53 04	Authorized officer A. Martín Moronta Telephone No. 91 3495377

Form PCT/ISA/210 (second sheet) (January 2015)

INTERNATIONAL SEARCH REPORT

International application No.

PCT/ES2016/070029

Information on patent family members

5
10
15
20
25
30
35
40
45
50
55

Patent document cited in the search report	Publication date	Patent family member(s)	Publication date
ES2230492T T3	01.05.2005	US2004155072 A1 US7014075 B2 EP1363840 A1 EP1363840 B1 EP1236652 A1 WO02074650 A1 DE60201661T T2 BR0207661 A BR0207661 B1 AT280095T T	12.08.2004 21.03.2006 26.11.2003 20.10.2004 04.09.2002 26.09.2002 28.04.2005 01.06.2004 29.05.2012 15.11.2004
ES2343856T T3	11.08.2010	AT471282T T WO2007087895 A1 EP1973798 A1 EP1973798 B1	15.07.2010 09.08.2007 01.10.2008 16.06.2010
DE19840858 A1	16.03.2000	NONE	
ES1078137U U	28.11.2012	ES1078137Y Y	25.02.2013
FR2900909 A1	16.11.2007	NONE	
XP002755082 A	04.03.2016	NONE	