

S. W. NYCE.
 Improvement in Sawing Machines.
 No. 125,215.

Patented April 2, 1872.

Fig. 1.

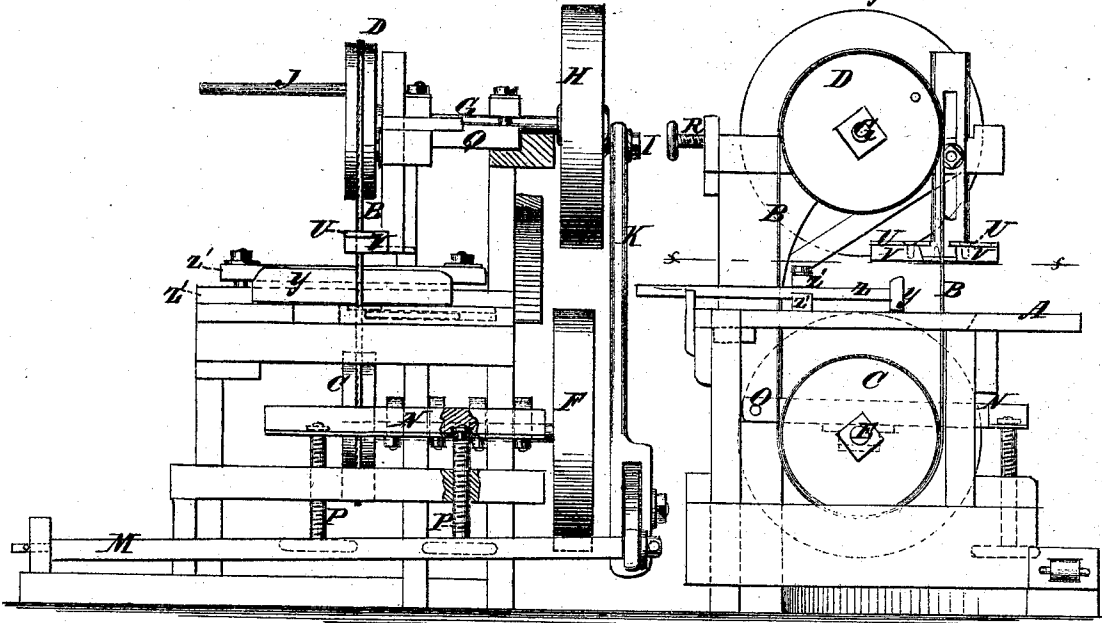

Fig. 2.

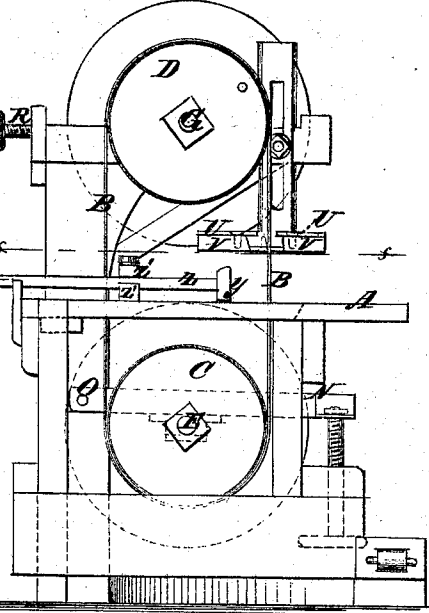

Fig. 3.

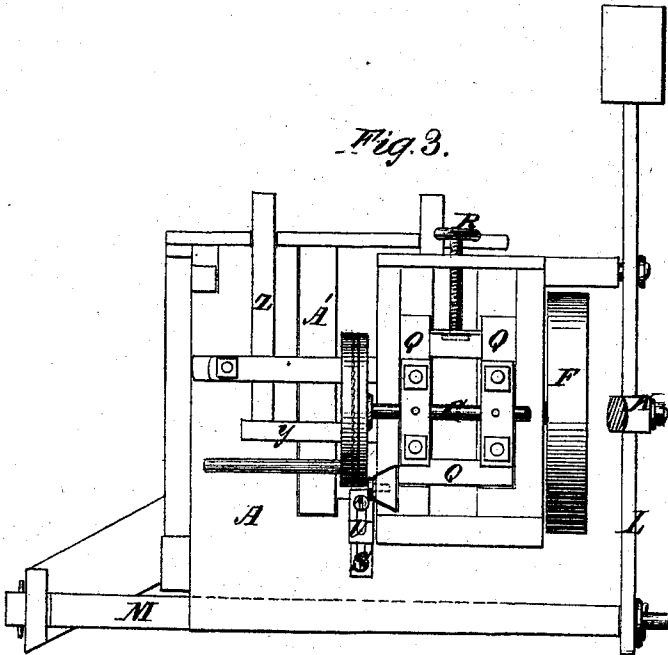
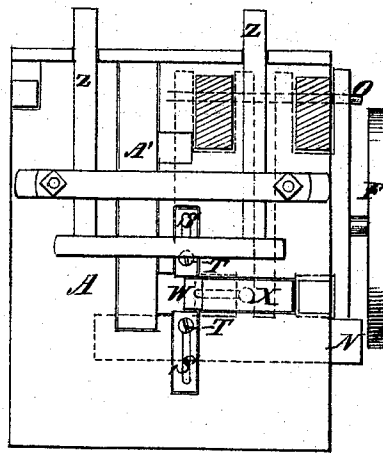

Fig. 4.



Witnesses:

John Becker.
 Geo. W. Mabee

Inventor:

S. W. Nyce

PER

Munnell
 Attorneys.

UNITED STATES PATENT OFFICE.

SAFARYNE W. NYCE, OF BLOOMING GROVE, PENNSYLVANIA.

IMPROVEMENT IN SAWING-MACHINES.

Specification forming part of Letters Patent No. 125,215, dated April 2, 1872.

Specification describing a new and Improved Sawing-Machine, invented by SAFARYNE W. NYCE, of Blooming Grove, in the county of Pike and State of Pennsylvania.

The invention will first be fully described, and then clearly pointed out in the claim.

Figure 1 is a front elevation of my improved machine, with some parts sectioned. Fig. 2 is a side elevation. Fig. 3 is a top view; and Fig. 4 is a horizontal section taken on the line *x x* of Fig. 2.

Similar letters of reference indicate corresponding parts.

A represents the saw-table; B, the saw; C, the lower saw-pulley; and D, the upper one. The shaft E of pulley C is provided with a driving-pulley, F, by which power may be applied from any suitable source, and the shaft G is also provided with a pulley, H, both for a balance and to apply a driving-belt; and to this pulley, which is provided with a wrist-pin, I, a connecting-rod, K, is attached, said rod being connected at the other end with a balance-lever, L, which is worked by a treadle, M, for driving the machine with foot-power. The pulley D is provided with a crank-pin or handle, J, by which the machine may be worked by hand. The shaft E of the lower saw-pulley is mounted on a frame, N, which is pivoted to the main frame at O for vertical adjustment; and it is connected at the other end by adjusting-screws P, whereby it is raised and lowered for adjusting the tension of the saw. The upper shaft G is mounted on a frame, Q, arranged to slide on the main frame in a direction perpendicular to the axis of said shaft, for adjusting the saw to work vertically or obliquely, whereby it will cut square or beveling. Said frame is adjusted by the screw R. The side guides S for the saw are arranged for sliding along in grooves in the upper surface of the table, to be shifted

with the saw as it is adjusted, as above described, for square or bevel sawing, the said guides being slotted, and held by clamp-screws T passing through the shaft, and screwing into the table, which screws are unscrewed to allow of moving said guides, and screwed down again to hold them fast. The side guides U, in the vertically-adjustable support V, therefore, above the table, are similarly arranged to be shifted with the saw. The back guide W is also arranged in like manner for adjustment, as may be required for wide or narrow saws; and in order that it may not interfere with the side guides S it is sunk in a deeper recess than those for said guides S, and works under them, the recess being filled in flush with the top of the table by a removable piece, X. The work-guide *y* has an arm, Z, extending rearward from each end, between the clamping-bars Z', and is held in position by them when clamped upon said arms by screws in such manner that the guide may readily be adjusted for parallel or tapering work. Below this work-guide a piece, A', of the table, fronting each hole through said table for the saw, is arranged for being readily removed when the work-guide is taken off to put in or take out the saw. These several devices and arrangements thereof constitute a very efficient and desirable machine.

Having thus described my invention, I claim as new and desire to secure by Letters Patent—

The combination of saw-shafts E G, provided with driving-pulleys F H, and having foot-power apparatus I K L M, and hand-crank pin J, all substantially as specified.

SAFARYNE W. NYCE.

Witnesses:

GEORGE AMMERMAN,
JAMES MILLHAM.