

(19) World Intellectual Property Organization
International Bureau



(43) International Publication Date
12 July 2001 (12.07.2001)

PCT

(10) International Publication Number
WO 01/49229 A1

- (51) International Patent Classification⁷: A61F 13/15
- (21) International Application Number: PCT/US00/33070
- (22) International Filing Date: 6 December 2000 (06.12.2000)
- (25) Filing Language: English
- (26) Publication Language: English
- (30) Priority Data:
09/477,904 5 January 2000 (05.01.2000) US
- (71) Applicant (for all designated States except US): CON-FAB SERVICES, AG [CH/CH]; Schwertzstrasse, No. 9, CH-8200 Schaffhausen (CH).
- (71) Applicant and
(72) Inventor: GLAUG, Frank, S. [US/US]; 110 Crimson Place, Chester Springs, PA 19425 (US).
- (72) Inventor; and
(75) Inventor/Applicant (for US only): SERAFINO, Jean, A. [US/US]; 49 Walnut Street, Clifton Heights, PA 19018 (US).
- (74) Agent: STEIN, Barry, A.; Caesar, Rivise, Bernstein, Cohen & Pokotilow, Ltd., 12th Floor, Seven Penn Center, 1635 Market Street, Philadelphia, PA 19103-2212 (US).
- (81) Designated States (national): AE, AG, AL, AM, AT, AU, AZ, BA, BB, BG, BR, BY, BZ, CA, CH, CN, CR, CU, CZ, DE, DK, DM, DZ, EE, ES, FI, GB, GD, GE, GH, GM, HR, HU, ID, IL, IN, IS, JP, KE, KG, KP, KR, KZ, LC, LK, LR, LS, LT, LU, LV, MA, MD, MG, MK, MN, MW, MX, MZ, NO, NZ, PL, PT, RO, RU, SD, SE, SG, SI, SK, SL, TJ, TM, TR, TT, TZ, UA, UG, US, UZ, VN, YU, ZA, ZW.
- (84) Designated States (regional): ARIPO patent (GH, GM, KE, LS, MW, MZ, SD, SL, SZ, TZ, UG, ZW), Eurasian patent (AM, AZ, BY, KG, KZ, MD, RU, TJ, TM), European patent (AT, BE, CH, CY, DE, DK, ES, FI, FR, GB, GR, IE, IT, LU, MC, NL, PT, SE, TR), OAPI patent (BF, BJ, CF, CG, CI, CM, GA, GN, GW, ML, MR, NE, SN, TD, TG).
- Published:
— With international search report.
- For two-letter codes and other abbreviations, refer to the "Guidance Notes on Codes and Abbreviations" appearing at the beginning of each regular issue of the PCT Gazette.

(54) Title: INCONTINENT SHIELD FOR MALES

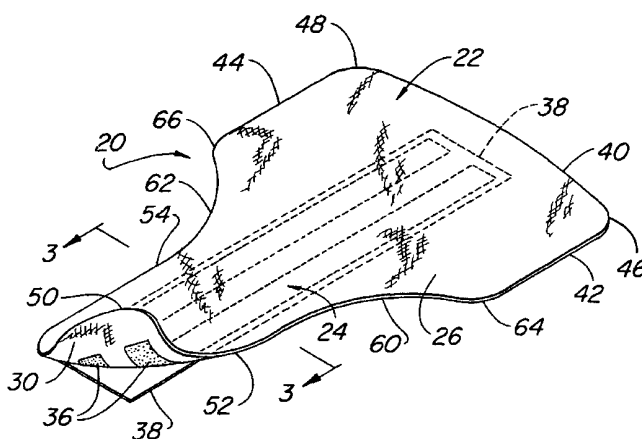

(57) Abstract: A disposable absorbent shield for men which arranged to be worn in an undergarment to trap and collect small amounts of leaking urine. The shield has a flexible chassis and a pair of side-by-side adhesive stripes on it to releasably mount it within the undergarment. The adhesive stripes are initially covered by a removable release strip until the shield is ready for use. The chassis includes a front portion arranged to be located over the penis and contiguous lower abdominal region and a crotch portion arranged to be located in the crotch and between the legs. The chassis is made up of an outer cover, an inner liner and a liquid absorbent core interposed therebetween. The chassis is a very thin planar flexible structure having a modified T-shaped periphery including an upper transverse portion forming the upper portion of the chassis and a downwardly extending longitudinal portion forming the crotch portion of the chassis. The upper portion merges with the crotch portion in a pair of gently curved sides which are shaped to readily accommodate the legs of the wearer. The chassis is arranged to be readily bent into a desired shape to fit within the undergarment and to conform to the body of the wearer.



WO 01/49229 A1

INCONTINENT SHIELD FOR MALES

FIELD OF THE INVENTION

This invention relates generally to disposable absorbent articles for males exhibiting minor incontinency, and more specifically to disposable absorbent shields which can be readily worn and concealed under clothing to prevent the soiling of such clothing by minor urine leakage.

BACKGROUND OF THE INVENTION

As populations continue to increase in longevity, incontinence, a problem of age presents a need for fluid control in undergarments. In particular, adult incontinence represents a transition from underwear to the use of some type of absorbent article to be added to the underwear or to completely replace it. For moderate-to-heavy incontinence needs a variety of disposable diaper designs are commercially available. Never the less certain deficiencies have been recognized in diapers that are currently found in the market place. For example, many of them, particularly high capacity designs, are thick and bulky, thus rendering concealment difficult. Moreover many of such prior art absorbent articles are complex in construction. See for example, United States Letters Patent Nos. 5,520,673 (Yarbrough et al.), 5,876,390 (Hall et al.), 5,817,086 (Kling), and 5,947,948 (Roe et al.), all of which disclose absorbent articles which may be of various shapes, such as rectangular, trapezoidal, T-shaped, I-shaped, hour-glass shaped, but which include various elastic components and/or other structural features, such as adhesive mounting tabs. Not all prior art diapers are of such complex construction. See for example, United States Letters Patent No. 3,768,479 (Widlund). This patent discloses a disposable diaper which is T-shaped, whose transverse or wider upper portion is made thicker and includes an elastic insert for stability. Since the diaper will be used on infants concealability of the diaper is not a significant concern, as is the case with incontinence shields to be worn within undergarments by adults. Moreover, the simple T-shape of the diaper leaves much to be desired from the standpoint of conformability to the wearer's body.

For light-to-moderate incontinence needs, absorbent pads, guards, shields or absorbent inserts which are used in conjunction with underwear have proven generally acceptable. Nevertheless, such prior art pads, guards, shields and absorbent inserts

still leave much to be desired from the standpoint of concealability, comfort, cost, etc., for light or very minor incontinence (slight dripping or leakage).

OBJECTS OF THE INVENTION

Accordingly, it is a general object of this invention to provide a disposable absorbent shield which addresses the needs of the prior art.

5 It is another object of this invention to provide a disposable adult incontinent shield which is very thin and flexible to be readily worn and concealed under clothing.

It is still another object of this invention to provide a soft and flexible disposable incontinent shield.

SUMMARY OF THE INVENTION

10 A disposable absorbent shield arranged to be worn under clothing by a male person to trap and collect urine. The article is in the form of a flexible chassis having a front portion arranged to be located over the person's penis and contiguous lower abdominal region and a crotch portion arranged to be located over the person's crotch and between the person's legs. The chassis includes a liquid absorbent layer or core
15 (e.g., an air-laid absorbent material containing super absorbent powder, pulp and a binder), an outer cover or moisture barrier (e.g., a polymeric film), and an inner liner (e.g., a non-woven cover-stock, such as spun bonded polypropylene). The liquid absorbent core is interposed between the outer cover and the inner liner.

The chassis is a very thin (e.g., in the range of 0.2 mm - 6 mm and most
20 preferably \approx 1.0 mm thick), planar structure having a modified T-shaped periphery including an upper transverse portion (e.g., approximately 152 mm wide), forming the upper portion of the chassis and a downwardly extending longitudinal portion (e.g., approximately 245 mm long), forming the crotch portion of the chassis. The upper portion merges with the crotch portion in a pair of gently curved sides (e.g., radius of
25 curvature approximately 78 mm), shaped to readily accommodate the legs of the wearer. The chassis is arranged to be bent into a desired shape to conform to the body of the wearer.

In accordance with one preferred embodiment of the invention the shield includes an adhesive (e.g., two lines or stripes of pressure sensitive hot melt adhesive)
30 located on the outer cover (e.g., along the central axis of the shield) for releasably mounting the shield in an undergarment. The adhesive stripes are initially covered by

a removable release strip until the shield is ready for use, e.g., affixation to the inside of the undergarment so that the shield will block the egress of urine through the undergarment.

DESCRIPTION OF THE DRAWING

Fig.1 is an isometric view of a shield constructed in accordance with this invention;

Fig. 2 is an enlarged plan view of the underside of the shield shown in Fig. 1; and

Fig. 3 is an enlarged sectional view taken along line 3 - 3 of Fig. 1.

DETAILED DESCRIPTION OF THE PREFERRED EMBODIMENT

Referring now to the various figures of the drawing wherein like reference characters refer to like parts, there is shown in Fig. 1 a disposable absorbent article 20 constructed in accordance with one embodiment of this invention. The article 20 of Fig. 1 is in the form of an adult incontinent shield. The shield 20 basically comprises a chassis made up of an upper or front portion 22 and a lower crotch portion 24. The details of both portions will be described later. Suffice it for now to state that the shield is arranged to be mounted within an undergarment (not shown) so that the front portion 22 is located over the wearer's penis and contiguous lower abdominal region, while the crotch portion 24 is located at the crotch and between the wearer's legs.

As best seen in Fig. 3, the chassis is a very thin generally planar structure. In particular, the chassis may be any thickness in the range of 0.2 mm to 6 mm, with 1.0 mm being the most preferred thickness for the exemplary embodiment which will be described hereinafter. The chassis is formed of a liquid pervious inner liner or layer 26, a liquid absorbent, e.g., air-laid composite, core 28, and an outer cover or moisture barrier 30. The inner layer may be of any liquid pervious material. One particularly suitable material is a 17 gsm wettable non-woven coverstock, made of thermal bond polypropylene, available from PGI Nonwovens, Landisville, New Jersey. The inner layer 26 is attached directly on-top of the absorbent core 28 by a low add-on adhesive 32. One particularly suitable material for the adhesive 32 is available from National Starch and Chemical of Bridgewater, NJ under the trade designation #34-5637. The inner layer 26 may be formed of other material fibers (e.g., polyethylene, bi-component, polyester, rayon, cotton, etc.), fiber combinations (e.g., spunbond, air laid, wet laid,

hydroentangled, etc.), and basis weights may be used as well. In fact, if desired, the inner layer 26 may be formed of a liquid impermeable material, e.g., polymeric film, having plural apertures or pores extending therethrough so as to make the material liquid permeable.

5 The outer layer or moisture barrier 30 is attached directly on-top of the absorbent core 28 on the opposite side from the inner layer 26 by a high add-on adhesive 34. One particularly suitable material for the adhesive 34 is the same as for adhesive 32.

10 The core 28 can be made up of any suitable absorbent material, as well as combinations of different types of absorbent material(s). For example, in the preferred embodiment shown herein the absorbent core 28 is a composite formed of an air-laid absorbent material containing super absorbent polymer powder (SAP), wood pulp and a binder. Examples of SAP include polyacrylamides, polyvinyl alcohol, polyacrylates, various grafted starches, and the like. One particularly suitable super absorbent material is a cross-linked polysodium acrylate, which can be purchased from Chemdal Corporation, Palatine, Illinois, under the trademark ASAP 2260.

15 In order to hold the shield in place within the wearer's undergarment, the shield includes a pair of side-by-side stripes 36 of adhesive on the outer surface of the moisture barrier 28 extending along the longitudinal central axis of the shield for substantially the length of the shield. Any suitable positioning adhesive 36 can be used for the stripes, such as a pressure sensitive hot melt adhesive. One particularly suitable material for the positioning adhesive 36 is available from National Starch and Chemical of Bridgewater, NJ under the trade designation #34-5598. In order to protect the adhesive stripes 36 from degradation or being soiled by debris, a single release strip 38 (e.g., a release paper) is releasably secured over them. The release strip 38 can be formed of any suitable adhesive protective, yet easy to release, material. One particularly suitable material for the adhesive release strip 38 is available from Tekkote of Leonia, NJ under the trade designation #11636.

20 As best seen in Figs. 1 and 2, and as mentioned above, the chassis of the shield is of a modified T-shape. To that end the upper or transverse portion 22 includes a top edge 40 which is a gentle convex arc extending between a pair of linear sides 42 and 44. The top edge 40 merges with the linear side 42 in a curved corner 46 and

25

30

merges with the linear side 44 in another curved corner 48. The distance between the linear sides, i.e., the width of the upper portion 22, is approximately 152 mm. The lower or crotch portion 24 includes a bottom or rear edge 50 which is a convex arc extending between a pair of linear sides 52 and 54. The rear edge 50 merges with the linear side 52 in a curved corner 56 and merges with the linear side 54 in another curved corner 58. The distance between the linear sides 52 and 54, i.e., the width of the crotch portion 24, is approximately 64 mm. The linear side 52 of the crotch portion 24 merges with the linear side 42 of the upper transverse portion 22 in a gentle concave arcuate interface or edge 60. In a similar manner the linear side 54 of the crotch portion 24 merges with the linear side 44 of the upper transverse portion 22 in a gentle concave arcuate interface or edge 62. The radius of curvature of each of the arcuate edges 60 and 62 is sufficiently large to comfortably accommodate the inner surface of the thighs of the wearer. The arcuate edge 60 merges with the linear side 42 of the upper portion 22 in a curved corner 64, while the arcuate edge 62 merges with the linear side 44 of the upper transverse portion 22 in a curved corner 66. The distance between the crown of the top edge 40 and the crown of the bottom edge 50 measured along the central longitudinal axis of the shield is approximately 245 mm.

As should be appreciated by those skilled in the art from the foregoing, when the shield 20 is in place within the wearer's undergarment the front or upper portion 22 is disposed over the wearer's penis and lower abdomen region (thereby providing maximum coverage to prevent any leaking urine from contacting the wearer's undergarment), while the crotch portion 24 is located between the wearer's legs. Moreover, the gentle curved nature of the interface edges 62 and 64 between the upper portion and the crotch portion on each side of the shield ensures that there is good conformance with the inner surface of the wearer's thighs to prevent leakage of urine therefrom, while also rendering the shield comfortable and virtually invisible under the undergarment.

While the discussion heretofore has concentrated on the use of this shield on adult males, shields constructed in accordance with this invention can also be used by females, with or without slight modification, e.g., size changes, to accommodate the different anatomy involved. Thus, the use of gender related terms in this application is not to be limiting of the invention.

As should be appreciated from the foregoing the incontinent shield of the subject invention addresses the needs of the prior art for a concealable, comfortable, quiet, easy to conform to the wearer's body, shield to prevent the egress of small amount of urine. Moreover, the shield of this invention is a relatively low cost, easy to manufacture, compact article.

5 Without further elaboration the foregoing will so fully illustrate our invention that others may, by applying current or future knowledge, adopt the same for use under various conditions of service.

CLAIMS

1. A disposable absorbent shield arranged to be worn under clothing by a male person to trap and collect urine, said article comprising a flexible chassis having a front portion arranged to be located over the person's penis and contiguous lower abdominal region and a crotch portion arranged to be located over the person's crotch and between the person's legs, said chassis including a liquid absorbent core, an outer cover, and an inner liner, said liquid absorbent layer being interposed between said outer cover and said inner liner, said chassis being very thin, planar structure having a modified T-shaped periphery including an upper transverse portion forming said upper portion of said chassis and a downwardly extending longitudinal portion forming said crotch portion of said chassis, said upper portion merging with said crotch portion in a pair of gently curved sides shaped to readily accommodate the legs of the wearer, said chassis being arranged to be readily bent into a desired shape to conform to the body of the wearer.
2. The disposable absorbent shield of Claim 1 wherein said outer cover is fluid impervious.
3. The disposable absorbent shield of Claim 2 wherein said outer cover is formed of a polymeric film.
4. The disposable absorbent shield of Claim 1 wherein said inner liner comprises a moisture pervious material.
5. The disposable absorbent shield of Claim 4 wherein said material comprises a fibrous material or an apertured polymeric material.
6. The disposable absorbent shield of Claim 1 wherein said core is formed of an air-laid composite material.
7. The disposable absorbent shield of Claim 6 wherein said composite material additionally comprises a super absorbent polymer.
8. The disposable absorbent shield of Claim 1 wherein said outer cover is formed of a polymeric film, said inner liner is formed of a fibrous material or an apertured polymeric material, and said core is formed of an air-laid composite material including a super absorbent polymer.

9. The disposable absorbent shield of Claim 1 additionally comprising an adhesive located on said outer cover for mounting said absorbent shield in a garment.

10. The disposable absorbent shield of Claim 9 additionally comprising a release strip releasably secured over said adhesive.

5 11. The disposable absorbent shield of Claim 1 wherein said upper transverse portion is approximately 152 mm wide, and said downwardly extending longitudinal portion is approximately 254 mm long.

12. The disposable absorbent shield of Claim 1 said gently curved sides have a radius of curvature of approximately 76 mm.

10 13. The disposable absorbent shield of Claim 11 said gently curved sides have a radius of curvature of approximately 76 mm.

14. The disposable absorbent shield of Claim 1 wherein said chassis is in the range of approximately 0.2 mm to 6 mm thick.

15 15. The disposable absorbent shield of Claim 14 wherein said chassis is approximately 1.0 mm thick.

16. The disposable absorbent shield of Claim 13 wherein said chassis is in the range of approximately 0.2 mm to 6 mm thick.

17. The disposable absorbent shield of Claim 16 wherein said chassis is approximately 1.0 mm thick.

FIG. 1

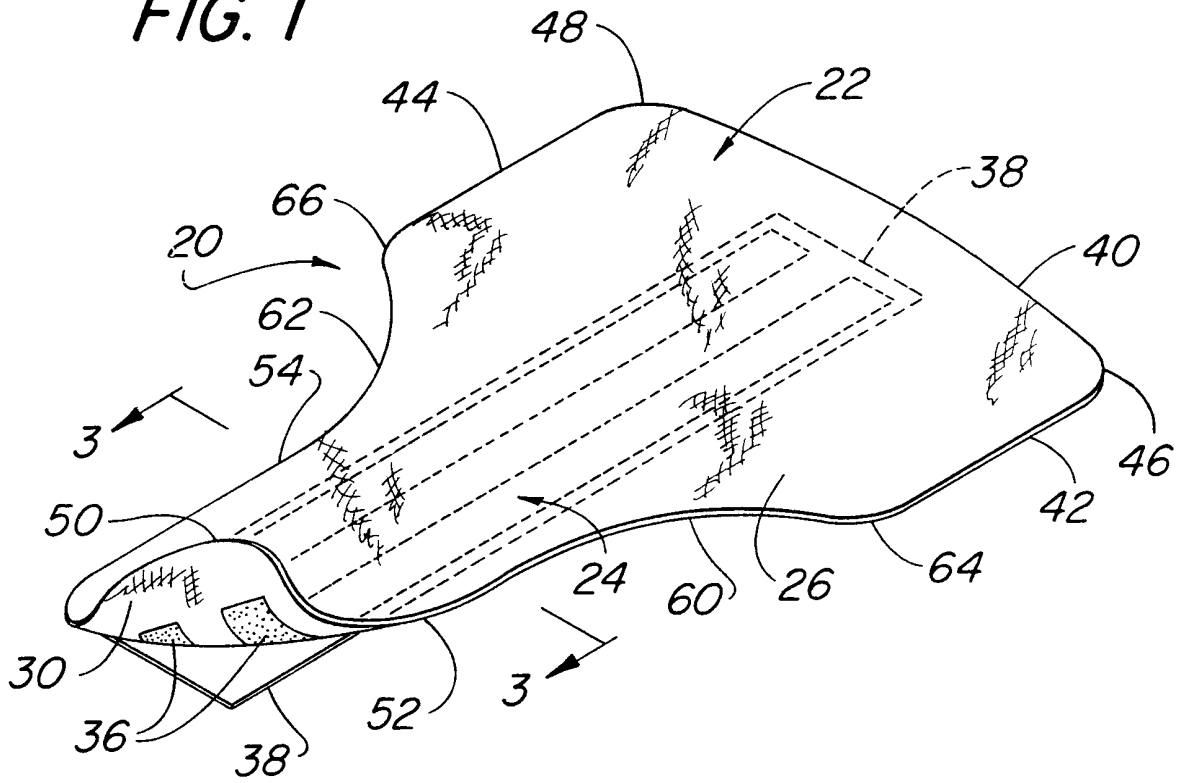

FIG. 3

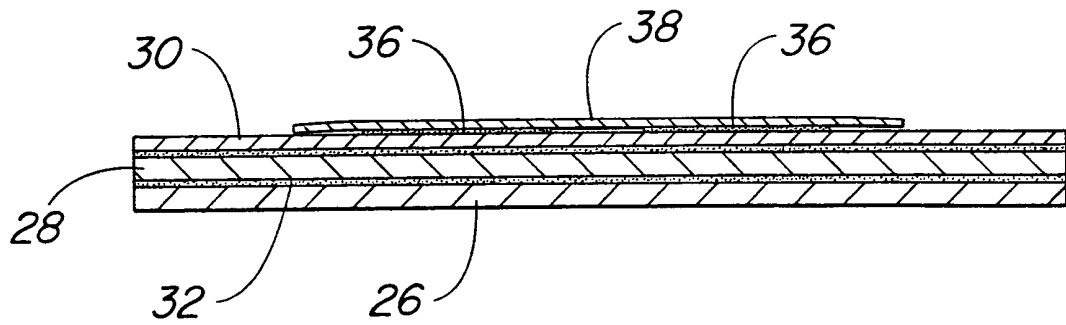
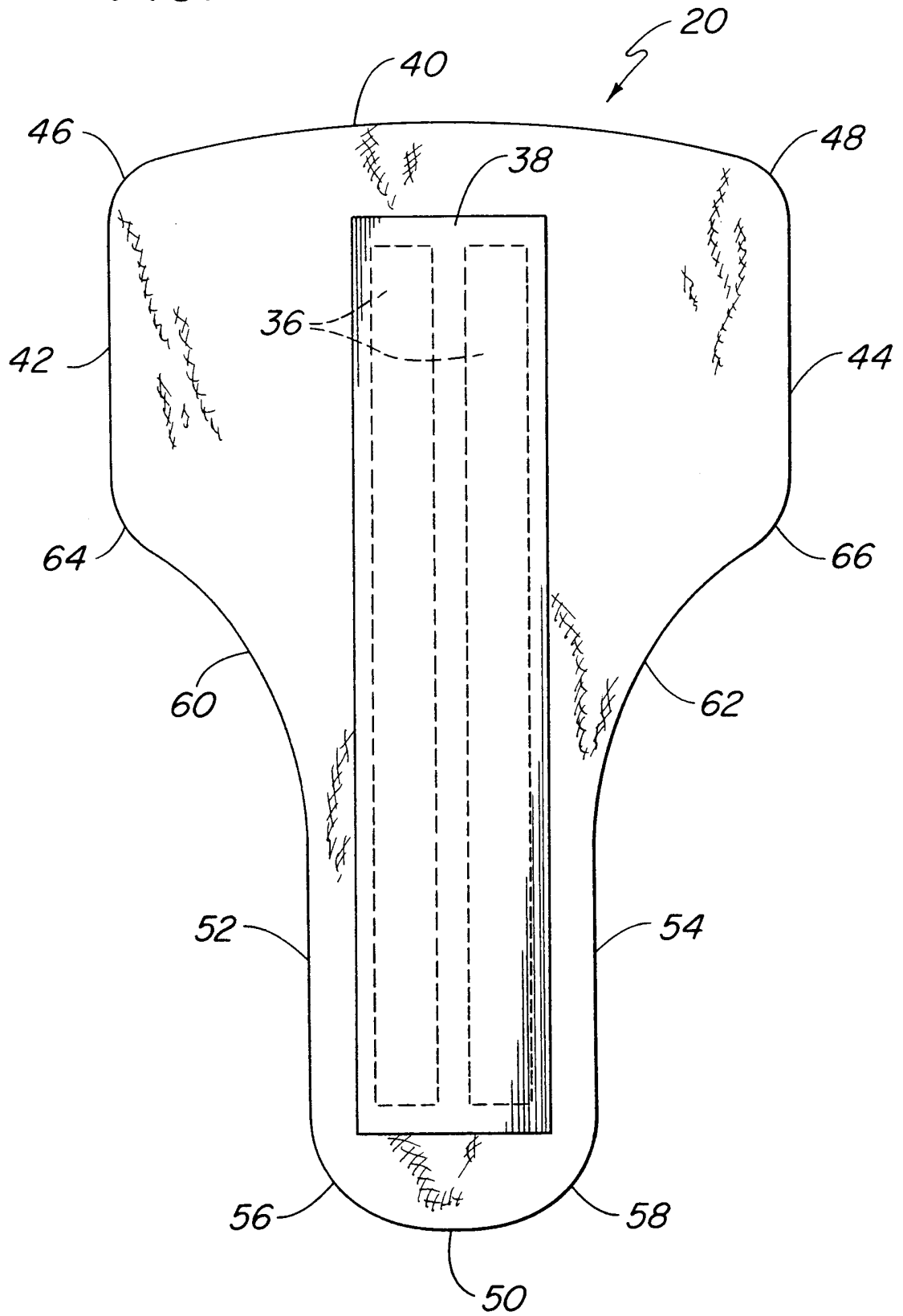

FIG. 2



INTERNATIONAL SEARCH REPORT

International Application No

PCT/US 00/33070

A. CLASSIFICATION OF SUBJECT MATTER

IPC 7 A61F13/15

According to International Patent Classification (IPC) or to both national classification and IPC

B. FIELDS SEARCHED

Minimum documentation searched (classification system followed by classification symbols)

IPC 7 A61F

Documentation searched other than minimum documentation to the extent that such documents are included in the fields searched

Electronic data base consulted during the international search (name of data base and, where practical, search terms used)

EPO-Internal

C. DOCUMENTS CONSIDERED TO BE RELEVANT

Category *	Citation of document, with indication, where appropriate, of the relevant passages	Relevant to claim No.
X	GB 2 319 187 A (SCA MÖLNLYCKE AB) 20 May 1998 (1998-05-20) page 12, line 29 -page 16, line 35; figures 1,2 ---	1-8, 11-17
X	US 3 768 479 A (LEIF WIDLUND) 30 October 1973 (1973-10-30) cited in the application the whole document ---	1
A	DE 296 02 160 U (EINE LIIMATAINEN) 4 April 1996 (1996-04-04) the whole document ---	1, 2, 4, 9, 11-17
X	FR 2 701 389 A (BOUSSIGNAC GEORGES) 19 August 1994 (1994-08-19) abstract; figures 1-6 ---	1, 2, 9-17
	-/--	

 Further documents are listed in the continuation of box C. Patent family members are listed in annex.

° Special categories of cited documents :

- *A* document defining the general state of the art which is not considered to be of particular relevance
- *E* earlier document but published on or after the international filing date
- *L* document which may throw doubts on priority claim(s) or which is cited to establish the publication date of another citation or other special reason (as specified)
- *O* document referring to an oral disclosure, use, exhibition or other means
- *P* document published prior to the international filing date but later than the priority date claimed

- *T* later document published after the international filing date or priority date and not in conflict with the application but cited to understand the principle or theory underlying the invention
- *X* document of particular relevance; the claimed invention cannot be considered novel or cannot be considered to involve an inventive step when the document is taken alone
- *Y* document of particular relevance; the claimed invention cannot be considered to involve an inventive step when the document is combined with one or more other such documents, such combination being obvious to a person skilled in the art.
- * & * document member of the same patent family

Date of the actual completion of the international search

6 March 2001

Date of mailing of the international search report

19/03/2001

Name and mailing address of the ISA

European Patent Office, P.B. 5818 Patentlaan 2
NL - 2280 HV Rijswijk
Tel. (+31-70) 340-2040, Tx. 31 651 epo nl.
Fax: (+31-70) 340-3016

Authorized officer

Seabra, L

INTERNATIONAL SEARCH REPORT

International Application No

PCT/US 00/33070

C.(Continuation) DOCUMENTS CONSIDERED TO BE RELEVANT

Category °	Citation of document, with indication, where appropriate, of the relevant passages	Relevant to claim No.
X	EP 0 966 933 A (THE PROCTER & GAMBLE COMPANY) 29 December 1999 (1999-12-29) claims; figures 1-4 ---	1-8, 11-17
A	DE 91 10 045 U (GÜNTNER MICHAEL) 21 November 1991 (1991-11-21) the whole document ---	1
A	US 3 747 602 A (HAROLD RALPH) 24 July 1973 (1973-07-24) abstract column 5, line 15-25; figure 5 ---	1
A	US 5 290 270 A (WARREN FISCHER) 1 May 1994 (1994-05-01) column 3, line 51 -column 4, line 19; figures ---	1
X	US 4 597 759 A (RUSSELL JOHNSON) 1 July 1986 (1986-07-01) abstract; figures ---	1,2,4, 11-17
A	DE 296 00 384 U (GEISLER-BEINENZ GUDRUN) 25 April 1996 (1996-04-25) figure 3 ---	1
X	US 5 439 458 A (NOEL, AHR) 8 August 1995 (1995-08-08) column 5, line 59 -column 6, line 27; figures 1-5 -----	1-17

INTERNATIONAL SEARCH REPORT

International Application No

PCT/US 00/33070

Patent document cited in search report		Publication date	Patent family member(s)	Publication date
GB 2319187	A	20-05-1998	SE 514462 C AU 726970 B AU 5074598 A EP 0944373 A PL 333360 A SE 9604222 A WO 9822058 A SK 62199 A	26-02-2001 30-11-2000 10-06-1998 29-09-1999 06-12-1999 22-06-1998 28-05-1998 14-02-2000
US 3768479	A	30-10-1973	SE 340077 B AT 320559 B BE 762695 A CA 1013501 A CH 525634 A DE 2106064 A DK 126965 B ES 194553 Y FI 51141 B FR 2078395 A GB 1345416 A JP 51032137 B LU 62563 A NL 7101552 A,B, NO 128943 B YU 31071 A,B	08-11-1971 25-02-1975 16-07-1971 12-07-1977 31-07-1972 19-08-1971 10-09-1973 16-04-1975 02-08-1976 05-11-1971 30-01-1974 10-09-1976 19-08-1971 12-08-1971 04-02-1974 25-09-1980
DE 29602160	U	04-04-1996	FI 2165 U	14-11-1995
FR 2701389	A	19-08-1994	NONE	
EP 0966933	A	29-12-1999	WO 0000113 A WO 0000112 A AU 4556199 A AU 4556399 A AU 4839099 A AU 4839199 A AU 5085499 A AU 8376298 A EP 0966937 A EP 0966935 A EP 0966934 A EP 0966936 A WO 0000114 A WO 0000111 A WO 0000115 A WO 0000110 A WO 0000116 A AU 8267198 A	06-01-2000 06-01-2000 17-01-2000 17-01-2000 17-01-2000 17-01-2000 17-01-2000 17-01-2000 29-12-1999 29-12-1999 29-12-1999 29-12-1999 06-01-2000 06-01-2000 06-01-2000 06-01-2000 06-01-2000 17-01-2000
DE 9110045	U	21-11-1991	NONE	
US 3747602	A	24-07-1973	NONE	
US 5290270	A	01-03-1994	NONE	
US 4597759	A	01-07-1986	NONE	
DE 29600384	U	25-04-1996	NONE	

INTERNATIONAL SEARCH REPORT

International Application No

PCT/US 00/33070

Patent document cited in search report	Publication date	Patent family member(s)	Publication date
US 5439458 A	08-08-1995	US 5304161 A	19-04-1994
		US 5460622 A	24-10-1995
		US 5486167 A	23-01-1996
		US 5681300 A	28-10-1997
		AT 119382 T	15-03-1995
		AU 665937 B	25-01-1996
		AU 9167191 A	17-08-1992
		BR 9107262 A	19-04-1994
		CA 2098322 A, C	04-07-1992
		CN 1066776 A	09-12-1992
		CZ 9301335 A	16-03-1994
		DE 69108059 D	13-04-1995
		DE 69108059 T	07-09-1995
		DK 565606 T	22-05-1995
		EP 0565606 A	20-10-1993
		ES 2069416 T	01-05-1995
		FI 933067 A	02-09-1993
		GR 3015375 T	30-06-1995
		HK 94296 A	07-06-1996
		HU 67763 A	28-04-1995
		HU 217875 B	28-04-2000
		IE 920010 A	15-07-1992
		JP 6503983 T	12-05-1994
		KR 231311 B	15-11-1999
		MX 9200019 A	01-08-1992
		NO 932372 A	03-09-1993
		NZ 241204 A	24-03-1997
		NZ 270804 A	24-10-1997
		NZ 328138 A	25-02-1999
		PL 168901 B	31-05-1996
		PT 99976 A	31-05-1994
		RU 2127573 C	20-03-1999
		SK 68393 A	11-05-1994
		TR 28310 A	09-04-1996
		WO 9211830 A	23-07-1992
		US 5849003 A	15-12-1998
		US 5658269 A	19-08-1997
		US 5702382 A	30-12-1997
		US 5611790 A	18-03-1997
		US 5713884 A	03-02-1998
		US 5674212 A	07-10-1997
		US 5683375 A	04-11-1997
		US 6059764 A	09-05-2000
		US 5824004 A	20-10-1998
