

J. P. SERVE.  
TUBULAR BOILER.

No. 521,442.

Patented June 12, 1894.

FIG. 1.

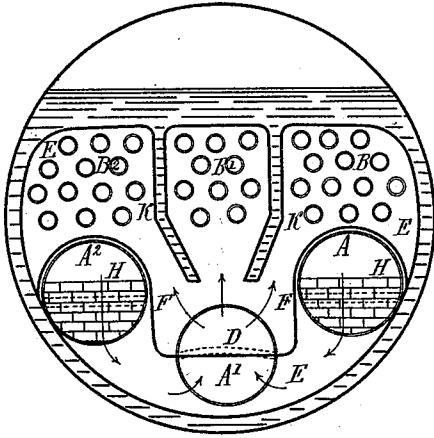

FIG. 3.

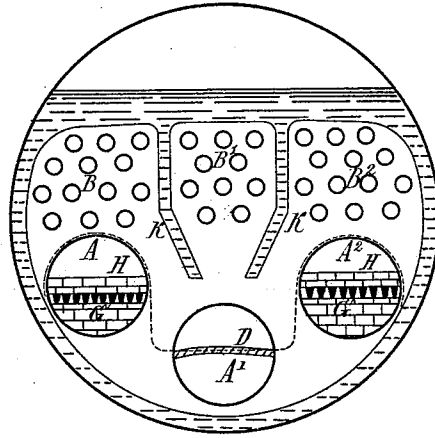
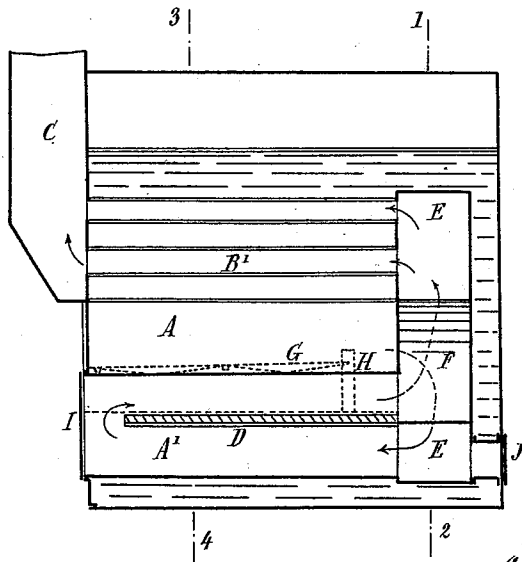

FIG. 2.



Witnesses:

Wm. A. Laurson Jr.

A. C. Pfaff.

Inventor  
Jean Pierre Serve.  
By his Attorney.

Edward P. Thompson

J. P. SERVE.  
TUBULAR BOILER.

No. 521,442.

Patented June 12, 1894.

FIG. 4.

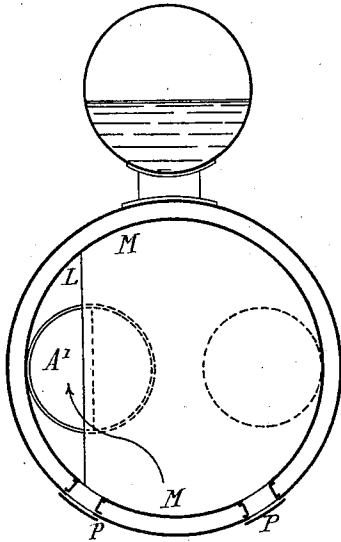

FIG. 6.

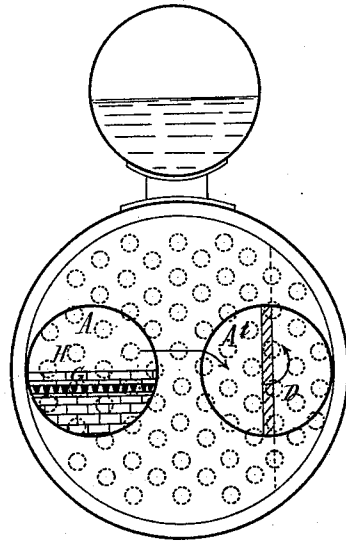
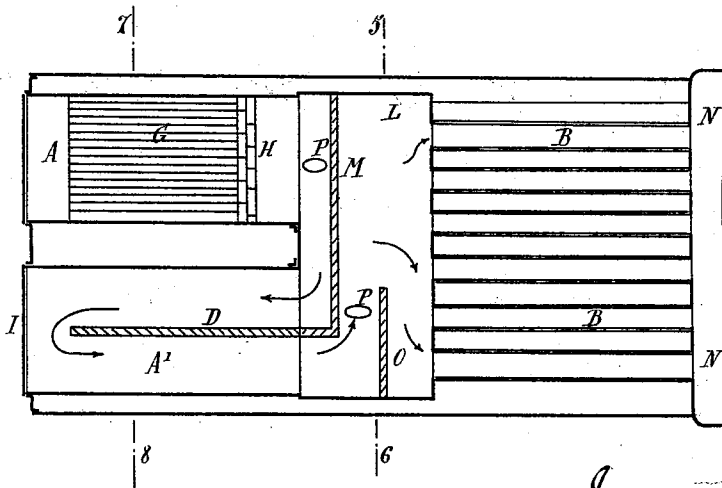

FIG. 5.



Witnesses:  
 Wm. A. Courson Jr.  
 A. C. Pfaff.

Inventor  
 Jean Pierre Serve.  
 By his Attorney  
 Edward P. Thompson

# UNITED STATES PATENT OFFICE.

JEAN PIERRE SERVE, OF LYONS, FRANCE.

## TUBULAR BOILER.

SPECIFICATION forming part of Letters Patent No. 521,442, dated June 12, 1894.

Application filed December 13, 1893. Serial No. 493,534. (No model.)

*To all whom it may concern:*

Be it known that I, JEAN PIERRE SERVE, engineer, a citizen of the Republic of France, residing at Lyons, in the said Republic of France, have invented certain new and useful Improvements in Tubular Boilers having Several Furnaces, of which the following is a specification.

This invention relates to improvements in steam boilers with several furnaces, more particularly marine boilers, with the object of allowing forced draft to be employed under favorable conditions, that is to say insuring a complete combustion of the gases before their introduction into the tubes, and avoiding the partial obstruction of these tubes by cinders, or sparks carried away by the current of air passing through the furnaces, without modifying the forms and arrangements customary in such boilers.

It consists essentially in dispensing with one of the furnaces of the boiler, and forcing the gases arising from the other furnaces to accomplish a double circulation in the cylindrical chamber which corresponds to the furnace which has been dispensed with, before passing into the groups of boiler tubes.

On the accompanying drawings there is shown as an example, in Figure 1 a vertical transverse section on the line 1, 2 of Fig. 2 passing through the combustion chamber of an ordinary marine boiler, having three furnaces. Fig. 2 is a longitudinal vertical section passing through the axis of this boiler. Fig. 3 is a vertical transverse section following the line 3, 4 of Fig. 2 passing through the furnace. Fig. 4 is a vertical section on the line 5, 6 of Fig. 5 passing through the combustion chamber of a double furnace boiler, in which the groups of tubes are placed in a prolongation of the furnaces. Fig. 5 is a horizontal longitudinal section of the boiler. Fig. 6 is a vertical section on the line 7, 8 of Fig. 5 passing through the furnaces.

The improvements introduced in marine boilers having three furnaces, such as are shown in Figs. 1, 2 and 3 merely consist in placing a grate in each of the two side chambers A and A<sup>2</sup> and in forcing the gases arising from these two furnaces to describe a double course through the central chamber A', which for this object is divided by means of

a longitudinal partition D before such gases pass into the three groups of tubes B, B' and B<sup>2</sup> ending at the chimney C. For this object, I arrange the combustion chamber E in such a way as to inclose the ends of the three chambers A, A' and A<sup>2</sup> and the three groups of boiler tubes, and I divide this box into two parts by means of a partition F, shaped in such a way, as to cause the ends of the furnaces A and A<sup>2</sup> to communicate with that part of the chamber A' which is below the horizontal partition D hereinbefore mentioned, and to place in communication the upper part of this chamber A' with the three groups of tubes B, B' and B<sup>2</sup> as may be seen clearly in Fig. 1.

The gases arising from the combustion on the grates G after having passed over the bridge H descend into the compartment of the combustion chamber situated below the partition F and pass into the lower part of the chamber A' which brings them back to the front of the boiler; they then pass round the horizontal partition D as is shown by the arrows, and return to the rear of the boiler, where they flow into the upper compartment of the combustion chamber; finally they accomplish their fourth journey by passing through the groups of tubes B, B' and B<sup>2</sup> before escaping by the chimney C. Under these conditions, cinders or sparks which may be carried away by the current of air, are deposited in the cylindrical body A', from which they may be easily removed by means of the door I or by means of an opening J for cleaning, situated at the rear.

The combustion is fully completed in the chamber A', owing to the high temperature which prevails there and the stirring action of the gases which pass through it.

I terminate the vertical partitions K (which have double casings, and which divide the upper part of the combustion chamber) by prolongations inclined slightly toward each other which regulate the size of the openings for the passage of the gases at the moment of their arrival at the groups of tubes B, B' and B<sup>2</sup>. It is evident that the use of forced draft will enable as much and even more fuel to be burned on the two grates G G than it was possible to do by means of the ordinary draft on three boiler grates of the same kind, and that

consequently the power of producing steam may be maintained or increased as may be desired.

When this system is to be applied to boilers in which the groups of tubes are placed in a prolongation of the furnaces, the means employed are the same as those hereinbefore described. In the case of a double furnace boiler, such as is shown in Figs. 4, 5 and 6 one of the chambers A is alone provided with a grate G and the other chamber A' is divided by means of a longitudinal partition D placed vertically, which may be arranged as in the preceding case and formed either of fire resisting materials, or of a flat boiler. In the cylindrical combustion chamber L, I arrange a vertical partition M which forces the gases coming from the grate G to pass into the chamber A' where they pass round the partition D as shown by the arrows, in order to return into the rear compartment of the chamber L, from whence they pass into the tubes B and from there into the smoke box N, which carries the chimney.

On the drawings, I have shown the use of a partition or zigzag O intended to insure the distribution of the gases in the group of tubes B; any other suitable means may however be employed for this object. This arrangement, like the one previously described, insures the complete combustion of the gases before their entrance into the tubes, and cinders carried away with them may be easily removed by means of the door I or by the cleaning openings P P. It is easily understood that after the examples which have been hereinbefore described, the invention may be applied without difficulty to all kinds of tubular boilers with several furnaces whatever may be in other respects their forms and particular arrangements. It must be understood that I do not limit myself to the forms and special arrangements shown on the drawings for the practical realization of the invention. Thus the longitudinal partition D of the body A' in place of being formed of bricks, may be made of a flat boiler if preferred; also the partition F instead of being formed of

sheet metal may, if preferred, be formed of fire resisting materials in order to resist the action of the heat.

Finally in the case of a three furnace boiler, the chamber A' may be divided into three parts by two vertical partitions, each of the side parts corresponding respectively to the furnaces A and A<sup>2</sup>, and the central part serving to return the gases to the rear of the boiler.

I declare that what I claim is —

1. In a double-furnace boiler the combination of the internal chamber A provided with a grate G, the other internal chamber A' provided with a longitudinal partition D, a combustion chamber L divided into two compartments by means of a partition M and having a partition O serving to distribute the gases in the boiler, substantially as hereinbefore described and shown.

2. In a boiler having furnaces and boiler tubes, the combination of lateral internal chambers provided with grates, an intermediate chamber provided with a longitudinal partition, and a combustion chamber divided into two compartments by a partition, one of the compartments connecting with the said lateral chamber, and the other with the boiler tubes.

3. In a boiler having furnaces and boiler tubes, the combination of lateral internal chambers provided with grates, an intermediate chamber provided with a longitudinal partition, and a combustion chamber divided into two compartments by a partition, one of the compartments connecting with the said lateral chamber, and the other with the boiler tubes, and partitions K, dividing the boilers into three groups and bent toward each other, away from the said lateral chambers and toward the intermediate chamber.

In testimony whereof I have signed my name to this specification in the presence of two subscribing witnesses.

JEAN PIERRE SERVE.

Witnesses:

EUGENE LOUIS DUMAS,  
CHARLES BAILLY.