

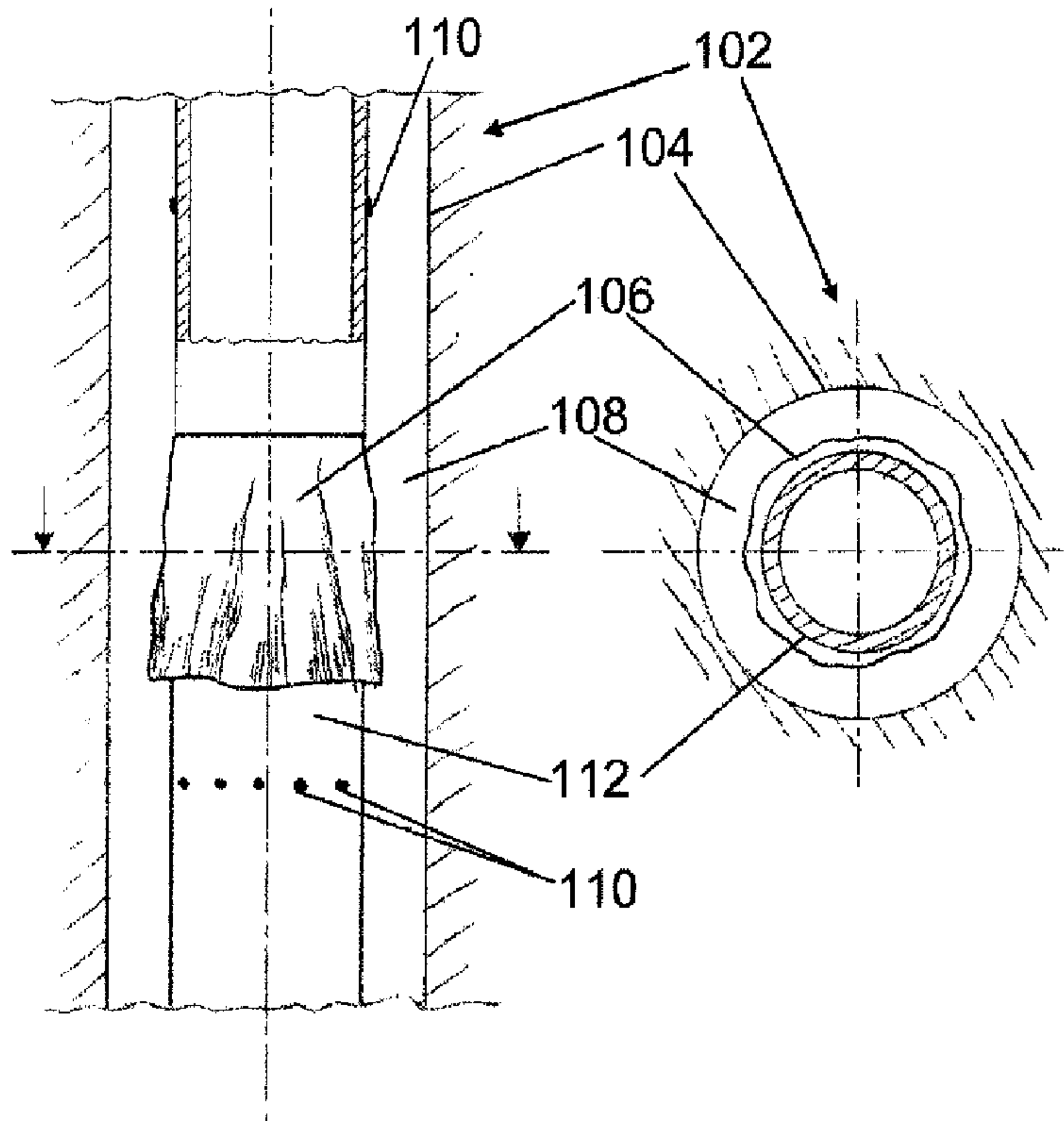

(86) Date de dépôt PCT/PCT Filing Date: 2011/07/07
 (87) Date publication PCT/PCT Publication Date: 2012/01/12
 (45) Date de délivrance/Issue Date: 2014/05/27
 (85) Entrée phase nationale/National Entry: 2013/01/08
 (86) N° demande PCT/PCT Application No.: EP 2011/061556
 (87) N° publication PCT/PCT Publication No.: 2012/004366
 (30) Priorités/Priorities: 2010/07/08 (DE10 2010 026 592.6);
 2010/11/08 (DE10 2010 050 494.7)

(51) Cl.Int./Int.Cl. *E21B 33/12* (2006.01)
 (72) Inventeur/Inventor:
 SPLITTSTOESSER, WULF, DE
 (73) Propriétaire/Owner:
 SPLITTSTOESSER, WULF, DE
 (74) Agent: BLAKE, CASSELS & GRAYDON LLP

(54) Titre : OBTURATEUR DE Puits DE FORAGE
 (54) Title: CLOSURE FOR A DRILL HOLE



(57) Abrégé/Abstract:

The object of the invention is to provide a device for closing a drill hole (102), which can be universally used and is capable of closing the drill hole (102) even in the case of damages which are located below a blowout preventer that may be present. The invention is based on the idea of introducing a closure into the drill hole (102) in order to seal the same in the event of damage and rising fluid. To this end, the closure comprises at least one skirt (106) or one capsule (401). A non-positive and/or positive connection to the wall (104) of the drill hole (102) is achieved by opening the skirt (106) or expanding the capsule, so that the drill hole (102) is closed.

(12) NACH DEM VERTRAG ÜBER DIE INTERNATIONALE ZUSAMMENARBEIT AUF DEM GEBIET DES PATENTWESENS (PCT) VERÖFFENTLICHTE INTERNATIONALE ANMELDUNG

(19) Weltorganisation für geistiges

Eigentum

Internationales Büro

(43) Internationales

Veröffentlichungsdatum

12. Januar 2012 (12.01.2012)



(10) Internationale Veröffentlichungsnummer

WO 2012/004366 A3

(51) Internationale Patentklassifikation:

E21B 23/06 (2006.01) E21B 33/126 (2006.01)

(21) Internationales Aktenzeichen: PCT/EP2011/061556

(22) Internationales Anmeldedatum: 7. Juli 2011 (07.07.2011)

(25) Einreichungssprache: Deutsch

(26) Veröffentlichungssprache: Deutsch

(30) Angaben zur Priorität:

10 2010 026 592.6 8. Juli 2010 (08.07.2010) DE

10 2010 050 494.7
8. November 2010 (08.11.2010) DE

(72) Erfinder; und

(71) Anmelder : SPLITTSTOESSER, Wulf [DE/DE];
Luisenstraße 4, 65779 Kelkheim/Ts. (DE).(74) Anwalt: KÖLLNER, Malte; Vogelweidstr. 8, 60596
Frankfurt am Main (DE).(81) Bestimmungsstaaten (soweit nicht anders angegeben, für
jede verfügbare nationale Schutzrechtsart): AE, AG, AL,

AM, AO, AT, AU, AZ, BA, BB, BG, BH, BR, BW, BY, BZ, CA, CH, CL, CN, CO, CR, CU, CZ, DE, DK, DM, DO, DZ, EC, EE, EG, ES, FI, GB, GD, GE, GH, GM, GT, HN, HR, HU, ID, IL, IN, IS, JP, KE, KG, KM, KN, KP, KR, KZ, LA, LC, LK, LR, LS, LT, LU, LY, MA, MD, ME, MG, MK, MN, MW, MX, MY, MZ, NA, NG, NI, NO, NZ, OM, PE, PG, PH, PL, PT, RO, RS, RU, SC, SD, SE, SG, SK, SL, SM, ST, SV, SY, TH, TJ, TM, TN, TR, TT, TZ, UA, UG, US, UZ, VC, VN, ZA, ZM, ZW.

(84) Bestimmungsstaaten (soweit nicht anders angegeben, für
jede verfügbare regionale Schutzrechtsart): ARIPO (BW, GH, GM, KE, LR, LS, MW, MZ, NA, SD, SL, SZ, TZ, UG, ZM, ZW), eurasisches (AM, AZ, BY, KG, KZ, MD, RU, TJ, TM), europäisches (AL, AT, BE, BG, CH, CY, CZ, DE, DK, EE, ES, FI, FR, GB, GR, HR, HU, IE, IS, IT, LT, LU, LV, MC, MK, MT, NL, NO, PL, PT, RO, RS, SE, SI, SK, SM, TR), OAPI (BF, BJ, CF, CG, CI, CM, GA, GN, GQ, GW, ML, MR, NE, SN, TD, TG).

Erklärungen gemäß Regel 4.17:

— Erfindererklärung (Regel 4.17 Ziffer iv)

[Fortsetzung auf der nächsten Seite]

(54) Title: CLOSURE FOR A DRILL HOLE

(54) Bezeichnung : VERSCHLUSS FÜR EIN BOHRLOCH

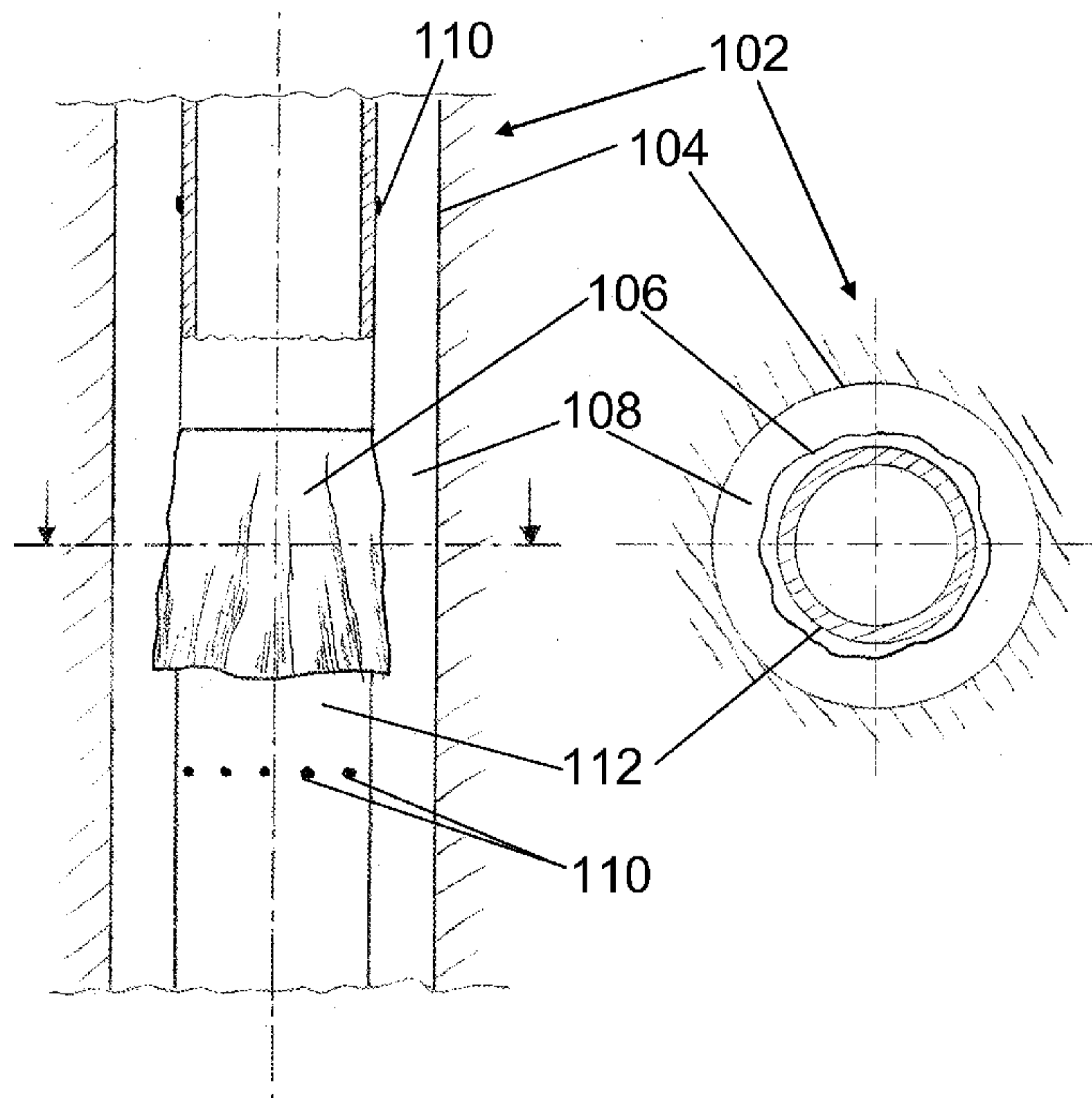

Fig. 1A

(57) **Abstract:** The object of the invention is to provide a device for closing a drill hole (102), which can be universally used and is capable of closing the drill hole (102) even in the case of damages which are located below a blowout preventer that may be present. The invention is based on the idea of introducing a closure into the drill hole (102) in order to seal the same in the event of damage and rising fluid. To this end, the closure comprises at least one skirt (106) or one capsule (401). A non-positive and/or positive connection to the wall (104) of the drill hole (102) is achieved by opening the skirt (106) or expanding the capsule, so that the drill hole (102) is closed.

(57) **Zusammenfassung:** Aufgabe der Erfindung ist es, eine Vorrichtung zum Verschließen eines Bohrlochs (102) anzugeben, die universell eingesetzt werden kann und in der Lage ist, das Bohrloch (102) auch bei Beschädigungen zu verschließen, die sich unterhalb eines möglicherweise vorhandenen Blowout-Preventers befinden. Zu Grunde liegt die Idee, einen Verschluss in das Bohrloch (102) einzuführen, um es im Schadensfall bei aufsteigendem Fluid abzudichten. Der Verschluss weist hierzu mindestens eine Schürze (106) bzw. eine Kapsel (401) auf. Durch Öffnen der Schürze (106) bzw. Aufdehnen der Kapsel kommt eine kraft- und/oder formschlüssige Verbindung zu der Wandung (104) des Bohrlochs (102) zustande, so dass das Bohrloch (102) verschlossen wird.

WO 2012/004366 A3 

Veröffentlicht:

- *mit internationalem Recherchenbericht (Artikel 21 Absatz 3)*
- *vor Ablauf der für Änderungen der Ansprüche geltenden Frist; Veröffentlichung wird wiederholt, falls Änderungen eingehen (Regel 48 Absatz 2 Buchstabe h)*

(88) Veröffentlichungsdatum des internationalen Recherchenberichts:

16. August 2012

1

CLOSURE FOR A DRILL HOLE

2

DESCRIPTION

3

Field of the invention

4

The invention relates to a seal for a wellbore in which a fluid, for instance oil or gas, flows up.

6

7

Prior art

8

So-called blowout preventers are known from the prior art. The term blowout preventer is used for various shut-off valves that are fitted directly over the wellbore in the case of a drilling operation. Blowout preventers serve to prevent a fluid from flowing out of the wellbore. This is necessary, in particular, if the drill string is damaged or if the drilling operation encounters a pressurized zone.

13

While a drilling operation is being performed, the drill string extends through the blowout preventer. If, in this case, there is an outflow of the fluid that cannot be stopped by other means, a two-stage mechanism comes into effect in the blowout preventer. In a first stage, seals are activated, which seal off the outer space around the drill string. Should this not suffice to stop an outflow of the fluid, the drill string is severed inside the blowout preventer. Subsequently, it is possible to seal the blowout preventer by means of shut-off slide valves.

19

In particular cases, however, it is questionable whether the dimensioning of the blowout preventer used is adequate for severing the drill string. A study commissioned by American federal authorities found in 2004 that only 3 out of 14 oil platforms have shearing stages that are sufficiently strong to sever the drill string.

23

The incident in the Gulf of Mexico has shown that the known methods used have considerable weaknesses and are highly susceptible to faults in respect of deployment and operation.

26

27

Object

28

It is the object of the invention to specify an apparatus for securing a wellbore, having the potential to close the wellbore, which is universally deployable and simultaneously avoids the disadvantages, mentioned at the outset, of known blowout preventers.

30

1 **Summary of the invention**

2 This object is achieved by the invention with the features of the independent claims.
3 Advantageous developments of the invention are characterized in the dependent claims. All
4 claims are hereby incorporated in this description by reference. The invention also includes all
5 appropriate and, in particular, all mentioned combinations of independent and/or dependent
6 claims.

7 The invention is based on the idea of providing a drill string, at intervals to be defined,
8 with a seal that unfolds if required, or of introducing a seal into a leaking wellbore in which a
9 fluid such as, for instance, oil or gas, rises, in order to seal off the wellbore below the leak. For
10 this purpose, a first seal according to the invention for a wellbore having a wall has a pipe that
11 can be introduced into the wellbore. The pipe can be composed of one or more pipe segments.

12 Furthermore, the seal has at least one apron, which is composed of a fluid-tight material
13 and which is fixed to the pipe in a fluid-tight manner. Consequently, no fluid can pass through
14 between the pipe and the at least one apron. The at least one apron can be introduced into the
15 wellbore by means of the pipe.

16 The at least one apron can assume a state in which it is folded towards the pipe, or non-
17 distended, and a state in which it is unfolded away from the pipe and towards the wall, or
18 distended. The pipe and the at least one apron are implemented in such a way that, in the state
19 in which the at least one apron is folded towards the pipe, there is a gap between the at least
20 one apron and the wall when the pipe is introduced into the wellbore. The fluid can then flow up
21 through the gap between the at least one apron and the wall.

22 In order to close the gap, the seal has means that can be activated. Activation of the
23 means that can be activated results in the at least one apron being able to assume the state in
24 which it is unfolded away from the pipe and towards the wall. Activation of the means that can
25 be activated, after the pipe has been introduced into the wellbore, results in the at least one
26 apron assuming the state in which it is unfolded away from the pipe and towards the wall, i.e.
27 the at least one apron is brought from the state in which it is folded towards the pipe to the state
28 in which it is unfolded away from the pipe and towards the wall. Means that can be activated
29 can be, for example, latches that can fasten or release the at least one apron.

30 A positive connection between the at least one apron and the wall is produced when the
31 pipe has been introduced into the wellbore and the at least one apron has assumed the state in
32 which it is unfolded away from the pipe and towards the wall. This connection fixes the seal
33 within the wellbore and prevents the seal from sliding out of the wellbore.

1 To enable such a connection between the at least one apron and the wall, the at least
2 one apron has at least one fixing element. The hardness of the at least one fixing element must
3 exceed the hardness of the wall. As a result, when the at least one apron changes from the
4 state in which it is folded towards the pipe to the state in which it is unfolded away from the pipe
5 and towards the wall, and is pressed against the wall, the at least one fixing element can
6 penetrate the wall. A positive connection is thereby produced between the at least one apron
7 and the wall. Examples of fixing elements are barbs or an upwardly directed linkage that
8 unfolds and wedges upon being activated.

9 The connection between the at least one apron and the wall is fluid-tight. Since,
10 furthermore, the at least one apron is composed of a fluid-tight material and is fixed to the pipe
11 in a fluid-tight manner, the gap is closed, such that no fluid can escape through the gap when
12 the pipe has been introduced into the wellbore and the at least one apron assumes the state in
13 which it is unfolded away from the pipe and towards the wall. The wellbore is thereby sealed
14 off.

15 The at least one apron is preferably designed such that the connection between the at
16 least one apron and the wall can be released by pulling on the pipe. By pulling on the pipe,
17 therefore, the seal can be removed from the wellbore if required.

18 It has proven advantageous that the change from the state in which the apron is folded
19 towards the pipe to the state in which it is unfolded away from the pipe and towards the wall is
20 effected passively, i.e. by means of a pressure applied to the at least one apron by the fluid
21 rising in the wellbore. For this purpose, the at least one apron, when in the state in which it is
22 folded towards the pipe, forms, together with the pipe, a gap-shaped pocket that can be entered
23 by the rising fluid. This produces the pressure required for bringing the at least one apron into
24 the state in which it is unfolded away from the pipe and towards the wall.

25 The activation of the means that can be activated then results in the pressure pressing
26 the at least one apron against the wall, such that the gap is closed and the non-positive or
27 positive connection between the at least one apron and the wall is produced.

28 The at least one apron is preferably designed in the form of a sack or umbrella. A
29 suitable material for the at least one apron is a flexible material that is resistant to the fluid, i.e.
30 whose physical properties do not alter upon contact with the fluid. The at least one apron can
31 possibly also be composed of a textile material or of a metal braided fabric that, for the purpose
32 of sealing, is coated with a suitable substance, possibly with a plastic, a plant-based polymer or
33 a biopolymer. Also suitable as material for the at least one apron are certain plastic films, or

1 films composed of a plant-based polymer, and possibly biopolymers. It has proven
2 advantageous in this case for the film or the textile material to be provided possibly with a
3 vapour-deposited metal coating as protection against destruction by the fluid. If necessary, the
4 at least one membrane can be provided with reinforcing ribs, in order to enable the at least one
5 membrane to function properly and to prevent damage. Alternatively, the at least one apron can
6 be composed of overlapping plastic or metal lamellae or of lamellae of textile material, as
7 described above.

8 In a preferred embodiment, the at least one pipe is a drill string, to which the apron - or,
9 as explained below, the capsule - is attached, in order to unfold if required and block the
10 unhindered outflow of fluid.

11 In a further preferred embodiment, instead of the drill string, the pipe can be an auxiliary
12 linkage. An auxiliary linkage refers to any pipe, other than the drill string, that serves to
13 introduce the seal into the wellbore and subsequently divert the fluid.

14 The fluid rising in the wellbore flows at a certain flow velocity. Once a particular
15 threshold value of the flow velocity is attained, the at least one apron unfolds. If the flow velocity
16 is too great, the at least one apron can be destroyed during the change from the state in which it
17 is folded towards the pipe to the state in which it is unfolded away from the pipe and towards the
18 wall. In order to prevent this, an advantageous development of the invention has a plurality of
19 aprons. These are disposed in succession along the pipe. At least one apron thereof is
20 preferably provided with a passage for the fluid. This passage reduces the kinetic energy of the
21 rising fluid. An apron that is located above, or behind, the apron provided with the passage can
22 protect the latter from being destroyed.

23 Another embodiment of the seal for the wellbore according to the invention has at least
24 one capsule composed of a fluid-tight material. Preferably, the material of the capsule is
25 plastically deformable, in order to ensure a stable anchoring of the seal. Metal, for instance,
26 would be suitable. However, the capsule can also be composed of a suitable unfoldable
27 material, for instance one of the above-mentioned materials of the apron.

28 The capsule is realized in such a way that there is a gap between the capsule and the
29 wall when the seal is introduced into the wellbore.

30 For the purpose of anchoring the seal in the wellbore, the seal has at least one
31 propellant charge. Activation of the at least one propellant charge causes the capsule to be
32 unfolded, or distended. Depending on the material selected, the capsule undergoes plastic

1 deformation. As a result of this, the capsule is pressed against the wall, such that a non-
2 positive and/or positive connection is produced between the capsule and the wall.

3 Suitable as a propellant charge are energy storage means such as, for example,
4 compressed gases, solid propellant charges or pyrotechnic propellant charges. The released
5 energy unfolds or distends the capsule, such that it is pressed against the wall.

6 Owing to the outer wall of the capsule being of appropriate consistence, the connection
7 between the capsule and the wall is positive and fluid-tight. Since the capsule is composed of a
8 fluid-tight material, no fluid can escape through the gap when the seal has been introduced into
9 the wellbore and the propellant charge has been activated. The wellbore is thereby sealed off.

10 Furthermore, the seal has a coupling. The latter serves to connect a pipeline to the seal.
11 A passage extends through the seal, such that fluid can flow through the seal and be drawn off
12 through the pipeline.

13 If, for example, the drill string has been ejected from the well bore because of an
14 incident, or has been removed from the latter for another reason, in a further advantageous
15 development of the invention the seal can have a drive, instead of the at least one pipe to which
16 it is attached and by means of which it has been introduced into the bore,. This drive enables
17 the seal to move within the fluid. Preferably, the drive is designed as a reaction drive, for
18 example as a rocket engine. A propeller engine can also be used as a drive.

19 In order for the drive to be capable of introducing the seal into the wellbore against the
20 upflowing fluid, the feed rate of the drive must exceed the flow velocity of the fluid in the
21 wellbore. The feed rate of the drive is to be understood as the velocity at which the drive
22 progresses relative to the fluid rising in the wellbore.

23 Instead of the drive, a pipe can be used to introduce the seal into the wellbore. For this
24 purpose, the seal is attached to the pipe. The connection between the seal and the pipe is fluid-
25 tight. The pipe can be the drill string or an auxiliary linkage.

26 In an advantageous development of the invention, the connection between the capsule
27 and the wall is positive and/or non-positive and fluid-tight. For this purpose, the outer surface of
28 the capsule is shaped accordingly. In a preferred embodiment, the outer surface of the capsule
29 has at least one fixing element. The hardness of the at least one fixing element must exceed
30 the hardness of the wall, so that the at least one fixing element can penetrate the wall when,
31 after the seal has been introduced into the wellbore, the capsule is distended and the outer
32 surface of the capsule is pressed against the wall. A positive connection is thereby produced

1 between the capsule and the wall of the wellbore. Here, likewise, examples of fixing elements
2 are, for example, barbs.

3 In a development of the seal, the latter can have a fixing pin that is mounted
4 displaceably relative to the capsule. The at least one propellant charge can act directly upon
5 the at least one fixing pin. Through activation of the at least one propellant charge, the at least
6 one fixing pin can be pushed at least partially out of the capsule. If the seal is inside the
7 wellbore and if the at least one fixing pin is pushed at least partially out of the capsule through
8 activation of the at least one propellant charge, the at least one fixing pin can penetrate the wall.

9 In order to seal the seal in respect to the wall of the wellbore, the seal has at least one
10 further propellant charge. Through activation of the at least one further propellant charge, the
11 capsule can be unfolded or distended and pressed against the wall.

12 Also advantageous is a development of the invention in which the seal can be
13 introduced ballistically into the wellbore. In this case, the seal is accelerated before entry into
14 the wellbore, i.e. it receives a kinetic energy. This energy is suitable for introducing the seal into
15 the wellbore up to a certain depth, where corresponding means that can be activated cause it to
16 unfold.

17 Further details and features are disclosed by the following description of preferred
18 exemplary embodiments in combination with the dependent claims. Each of the features in this
19 case can be realized singly, or multiply, in combination with one another. The possibilities for
20 achieving the objective are not limited to the exemplary embodiments. Thus, for example,
21 stated ranges always include all - unmentioned - intermediate values and all conceivable partial
22 intervals.

23 The exemplary embodiments are represented schematically in the figures. In this case,
24 identical reference numerals in the individual figures denote elements that are identical or that
25 have the same function, or that correspond to one another in respect to their functions. In
26 detail:

27 Fig. 1A shows a seal for a wellbore with an apron in the state in which it is folded
28 towards the pipe;

29 Fig. 1B shows a seal for a wellbore with an apron in the state in which it is
30 unfolded away from the pipe and towards the wall;

31 Fig. 2 shows a seal for a wellbore with an apron in the state in which it is
32 unfolded away from the pipe and towards the wall, with seals;

33 Fig. 3 shows a seal for a wellbore with reinforcing ribs and fixing elements;

1 Fig. 4 shows a seal for a wellbore in the manner of a torpedo; and

2 Fig. 5 shows a displaceable fixing pin.

3 Fig. 1A shows a seal that has been introduced into a wellbore 102 having a wall 104.

4 The seal has an apron 106. Between the apron 106 and the wall 104 there is a gap 108. In the
5 upper region, the apron 106 is fastened to a pipe 112 and is in the state in which it is folded
6 towards the pipe 112.

7 Sensors 110 measure data such as, for instance, the movement of the pipe 112, the
8 position of the pipe 112 relative to the wall 104, the hydrostatic pressure of the fluid surrounding
9 the seal, the distance travelled by the seal within the wellbore 102, or the flow velocity of the
10 fluid.

11 The apron 106 is fixed, by means that can be activated, in the state in which it is folded
12 towards the pipe 112. An activation of the means that can be activated, by the sensors 110,
13 releases the apron 106. Subsequently, fluid flowing under the apron 106 causes the apron 106
14 to open.

15 Fig. 1B shows the apron 106 in the state in which it is unfolded away from the pipe 112
16 and towards the wall. The pressure exerted upon the apron 106 by the rising fluid presses the
17 apron 106 against the wall 104. Consequently, a non-positive and/or positive and fluid-tight
18 connection is produced between the apron 106 and the wall 104. The apron 106 thus closes
19 the gap 108.

20 In order to improve the tightness of the connection against the fluid, seals 200, for
21 example in the form of O-rings, can be attached to the apron 106. This is represented as a
22 whole in Fig. 2 and as a detail Z. The pressure exerted upon the apron 106 by the rising fluid
23 causes a positive and/or non-positive, fluid-tight connection between the seals 200 and the wall
24 104.

25 The use of a flexible fabric or a film as an apron 106 is practicable, in particular, if the
26 pressure exerted upon the apron 106 by the rising fluid is low. In the case of higher pressures,
27 on the other hand, the exemplary embodiment shown in Fig. 3 is preferred. In this case,
28 reinforcing ribs 300 support the apron 106. The apron 106, which is not shown in Fig. 3 in order
29 to better visualize the reinforcing ribs 300, is positioned upstream of the reinforcing ribs so that
30 the apron 106, when in the unfolded state, is pressed against the reinforcing ribs 300. The
31 structure of the reinforcing ribs 300 is similar to the rod assembly of an umbrella. The
32 reinforcing ribs 300 stabilize the apron 106, centre the pipe 112 in the wellbore 102, and
33 additionally prevent damage to the apron 106 due to the pressure exerted by the fluid upon the

1 apron 106 when in the state in which it is unfolded away from the pipe 112 and towards the wall
2 104.

3 Seals 200, as represented in Fig. 2, are advantageous, in particular, if the wall 104 of the
4 wellbore 102 is composed of a hard material. A soft wall 104, on the other hand, makes it
5 possible to use the fixing elements 302, shown in detail Z of Fig. 3. The fixing elements 302 are
6 attached to the reinforcing ribs 300 and are composed of a hard material. In particular, the
7 material of the fixing elements 302 must be harder than the material of the wall 104. Preferably,
8 the fixing elements 302 have projections, for example in the form of barbs.

9 If the apron 106, when in the state in which it is unfolded away from the pipe 112 and
10 towards the wall 104, is pressed against the wall 104 by the pressure exerted upon the apron
11 106 by the fluid, this results in the projections of the fixing elements 302 penetrating the wall
12 104. A positive connection to the wall 104 is thereby produced.

13 In order to spare the material and increase safety, the apron 106 can be opened in a
14 step-wise manner. In a first step, the fixing elements 302 are pressed against the wall 104,
15 such that the projections of the fixing elements 302 penetrate the wall 104 and a positive
16 connection is produced in respect of the wall 104. In a second step, the gap 108 is closed by
17 transforming the apron 106 from the state in which it is folded towards the pipe 112 to the state
18 in which it is unfolded away from the pipe 112 and towards the wall 104. The fluid now flows
19 through the pipe 112. In a third step, valves present in the pipe 112 are closed. The wellbore
20 102 is thereby completely sealed off.

21 In the case of the exemplary embodiments shown in Figs. 1A, 1B, 2 and 3, the apron
22 106 is introduced into the wellbore 102 by means of the pipe 112, in the preferred embodiment
23 as an element of equipment of a drill string. The seal of Fig. 4, on the other hand, is designed in
24 the manner of a torpedo. In this case, a jet propulsion 400 generates sufficient thrust to
25 introduce the seal into the wellbore 102 against the rising fluid.

26 Instead of an apron 106, the seal represented in Fig. 4 has a capsule 401. The capsule
27 401 constitutes the outer envelope of the bulge of the seal. The lower part 401a of the capsule
28 401 is hemispherical and is provided with sensors 110.

29 Adjoining the hemispherical part of the capsule 401 there is a cylindrical part 401b of the
30 capsule 401. The cylindrical part 401b of the capsule 401 connects the hemispherical part 401a
31 of the capsule 401 to the upper part 401c thereof. Attached to the upper part 401c of the
32 capsule 401, in turn, are guiding elements 402 and a coupling 404.

1 The capsule 401 encloses propellant charges 408 and a solid carrier element 406 with
2 funnel-shaped indentations. Pyrotechnic propellant charges 408 are located within these
3 indentations.

4 A passage 414 goes through the hemispherical part 401a of the capsule 401, through
5 the carrier element 406, through the jet propulsion 400 and through the upper part 401c of the
6 capsule 401. The passage 414 extends lengthwise through the seal and connects an opening
7 in the spherical part 401a of the capsule 401 to an opening in the upper part 401c of the capsule
8 401 such that fluid can flow through the seal.

9 The guiding elements 402 serve to stabilize the seal while the latter is introduced into the
10 wellbore 102. The sensors 110 meanwhile acquire appropriate data. Thus, the sensors 110
11 can measure, for instance, the depth to which the seal has entered the wellbore 102 or, by
12 means of optical signals, they can detect damage to the wall 104.

13 In dependence on the acquired data, the sensors 110 initiate the activation of the
14 propellant charges 408. The energy that is released as a result causes the capsule 401 to be
15 unfolded, or distended, and pressed against the wall 104.

16 The capsule 401 is provided with fixing elements 302. The hardness of the fixing
17 elements 302 must exceed the hardness of the wall 104 of the wellbore 102. This enables the
18 fixing elements 302 to penetrate the wall 104 as a result of the activation of the pyrotechnic
19 propellant charges 408, such that the seal becomes anchored to the wall 104 by means of a
20 positive connection. As represented in detail Y of Fig. 4, the fixing elements 302 can be
21 designed as barbs.

22 The energy of the explosion of the propellant charges 408 causes the diameter of at
23 least one part of the capsule 401 to be enlarged. In order to ensure a defined deformation of
24 the capsule 401 in this case, the capsule 401 can have a predetermined breaking point 410, as
25 represented in detail X of Fig. 4. When the capsule 401 becomes distended, the lower part of
26 the capsule 401, consisting of the hemispherical part 401a of the capsule 401 and the cylindrical
27 part 401b of the capsule 401, detaches from the upper part 401c of the capsule 401 along the
28 predetermined breaking point 410. This prevents the remaining components of the seal, such
29 as, for instance, the passage 414 or the coupling 404, from being damaged as the capsule 401
30 distends.

31 The greater the gap that exists between the wall 104 and the capsule 401, the greater
32 are the requirements in respect of the deformability of the capsule 401. In order to prevent the
33 breaking limit for the material used for the capsule 401 from being exceeded as the capsule 401

1 distends, the capsule 401 can have expansion folds extending vertically beneath the
2 predetermined breaking point 410.

3 In the distended state, the cylindrical part of the capsule 401 bears flatly on the wall 104.
4 In this case, the hemispherical part of the capsule 401 connects the cylindrical part of the
5 capsule 401 to the inside of the seal. Consequently, no fluid can escape between the capsule
6 401 and the wall 104. The wellbore is now sealed off.

7 In order to continue using the wellbore 102, the seal has, next to the coupling 404 - as
8 represented in detail Z of Fig. 4 - a valve 412. The valve 412 opens and closes the passage
9 414. When the valve 412 is closed, no fluid can escape from the wellbore 102. When the valve
10 412 is open, on the other hand, the fluid is routed through the passage 414, and therefore
11 through the seal.

12 Apart from the disc valve 412 depicted, other types of valve can also be used, e.g. ball
13 valves or slide valves. The latter would have the advantage of requiring less force for opening.

14 The coupling 404 serves to connect a pipeline to the seal. This happens after the seal
15 has been anchored in the wall 104 through activation of the propellant charges 408. When the
16 valve 412 has been opened, the fluid can be drawn off through the pipeline and processed
17 further as intended.

18 The valve can also be open while the seal is being inserted in the wellbore, in order to
19 reduce the pressure upon the seal. There is then also the possibility of closing the valve only
20 when a pipeline has been connected to the coupling 404. Such a pipeline 404 is capable of
21 taking up portions of the increased forces after the valve has been closed.

22 It is possible for a plurality of seals, implemented as shown in Fig. 4, to be introduced
23 into the wellbore 102.

24 It is likewise possible for the embodiment as a capsule to be mounted as an element of
25 equipment of a drill string 112 and to be introduced into the wellbore 102.

26 Various embodiments can be combined according to differing safety considerations.

27 Fig. 5 shows a portion of the seal with at least one fixing pin 500. For the purpose of
28 guiding the at least one fixing pin 500, the carrier element 406 has a cylindrical bore 502. The
29 fixing pin 500 is mounted so as to be displaceable in the bore 502.

30 The bore 502 connects an opening 504 in the capsule 401 to a spherical ignition
31 chamber 506. Like the bore 502, the ignition chamber 506 is located in the carrier element 406,
32 i.e. it is surrounded by the carrier element 406, or is constituted by the carrier element 406.

1 The bore 502 does not extend vertically, but is inclined downwards by a certain angle
2 relative to the perpendicular. Consequently, owing to its gravitational force, the fixing pin 500
3 first slides along the bore 502 in the direction of the inside of the seal.

4 The ignition chamber 506 contains a propellant charge 408. When this is activated, the
5 released energy drives the fixing pin 500 away from the ignition chamber 506 in the direction of
6 the wall 104 of the wellbore 102. As a result, the fixing pin 500 passes through the gap 108 that
7 exists between the capsule 401 and the wall 104, and penetrates the wall 104. The seal is now
8 fixed to the wall 104.

9 The gap 108 can be closed - as described above - by unfolding or distending the
10 capsule 401, and pressing it against the wall 104. At least one propellant charge 408 thus
11 serves to unfold or distend the capsule, while at least one further propellant charge 408 drives
12 the fixing pin 500 into the wall 104.

13 In order to prevent the bore 502 and the at least one fixing pin 500 from being damaged
14 as the capsule 401 unfolds or distends, the bore 502 is preferably disposed such that the
15 opening 504 in the capsule 401 is located above the predetermined breaking point 410 in the
16 upper part 401c of the capsule 401.

References

102	wellbore
104	wall
106	apron
108	gap
110	sensor
112	pipe
200	seal
300	reinforcing rib
302	fixing element
400	jet propulsion
401	capsule
401a	spherical part of the capsule
401b	cylindrical part of the capsule
401c	upper part of the capsule
402	guiding element
404	coupling
406	carrier element
408	propellant charge
410	predetermined breaking point
412	valve
414	passage
502	bore
504	ignition chamber

Claims

1. Seal for a wellbore having a wall, wherein a fluid rises in the wellbore, comprising:
 - a) a pipe, which can be introduced into the wellbore;
 - b) at least one apron composed of a fluid-tight material,
 - b1) the at least one apron being fixed to the pipe in a fluid-tight manner;
 - b2) the at least one apron being able to assume a state in which it is folded towards the pipe and a state in which it is unfolded away from the pipe towards the wall;
 - b3) the pipe and the at least one apron being implemented in such a way that, when the at least one apron is in the state in which it is folded towards the pipe, there is a gap between the at least one apron and the wall when the pipe is introduced into the wellbore ;
 - b4) the at least one apron having at least one fixing element;
 - b5) the hardness of the at least one fixing element exceeding the hardness of the wall;
 - b6) such that the at least one fixing element can penetrate the wall when the at least one apron is pressed against the wall;
 - b7) such that a positive connection can be produced between the at least one apron and the wall; and comprising
 - c) an activator to cause the at least one apron to be able to assume the state in which it is unfolded away from the pipe and towards the wall.
2. Seal according to claim 1, wherein the at least one pipe is a drill string.
3. Seal according to claim 1, wherein the at least one pipe is an auxiliary linkage.
4. Seal according to any one of claims 1 to 3, wherein a plurality of aprons are disposed in succession along the pipe.
5. Seal for a wellbore having a wall, wherein a fluid rises in the wellbore, comprising:
 - a) at least one capsule composed of a fluid-tight material,
 - a1) the capsule being implemented in such a way that a gap exists between the capsule and the wall when the seal is introduced into the wellbore;
 - b) at least one propellant charge,

b1) the capsule being able to be distended by activation of the at least one propellant charge; and comprising

c) a coupling for connecting a pipeline to the seal;

d) a passage extending through the seal, such that the fluid can flow through the seal and can be drawn off through the pipeline.

6. Seal according to any one of claims 1 to 5, wherein a drive is provided to enable the seal to be moved progressively in the fluid.

7. Seal according to claim 5, wherein the seal is attached to a pipe that can be introduced into the wellbore.

8. Seal according to any one of claims 5 to 7, wherein
the outer surface of the capsule has at least one fixing element;
the hardness of the fixing element exceeds the hardness of the wall;
such that the at least one fixing element can penetrate the wall when the outer surface of the at least one capsule is pressed against the wall.

9. Seal according to any one of claims 5 to 8, wherein
the seal has at least one fixing pin, which can be pushed at least partially out of the capsule by activation of the at least one propellant charge ;
the hardness of the at least one fixing pin exceeds the hardness of the wall;
such that the at least one fixing pin can penetrate the wall when the at least one fixing pin is pushed at least partially out of the capsule by activation of the at least one propellant charge.

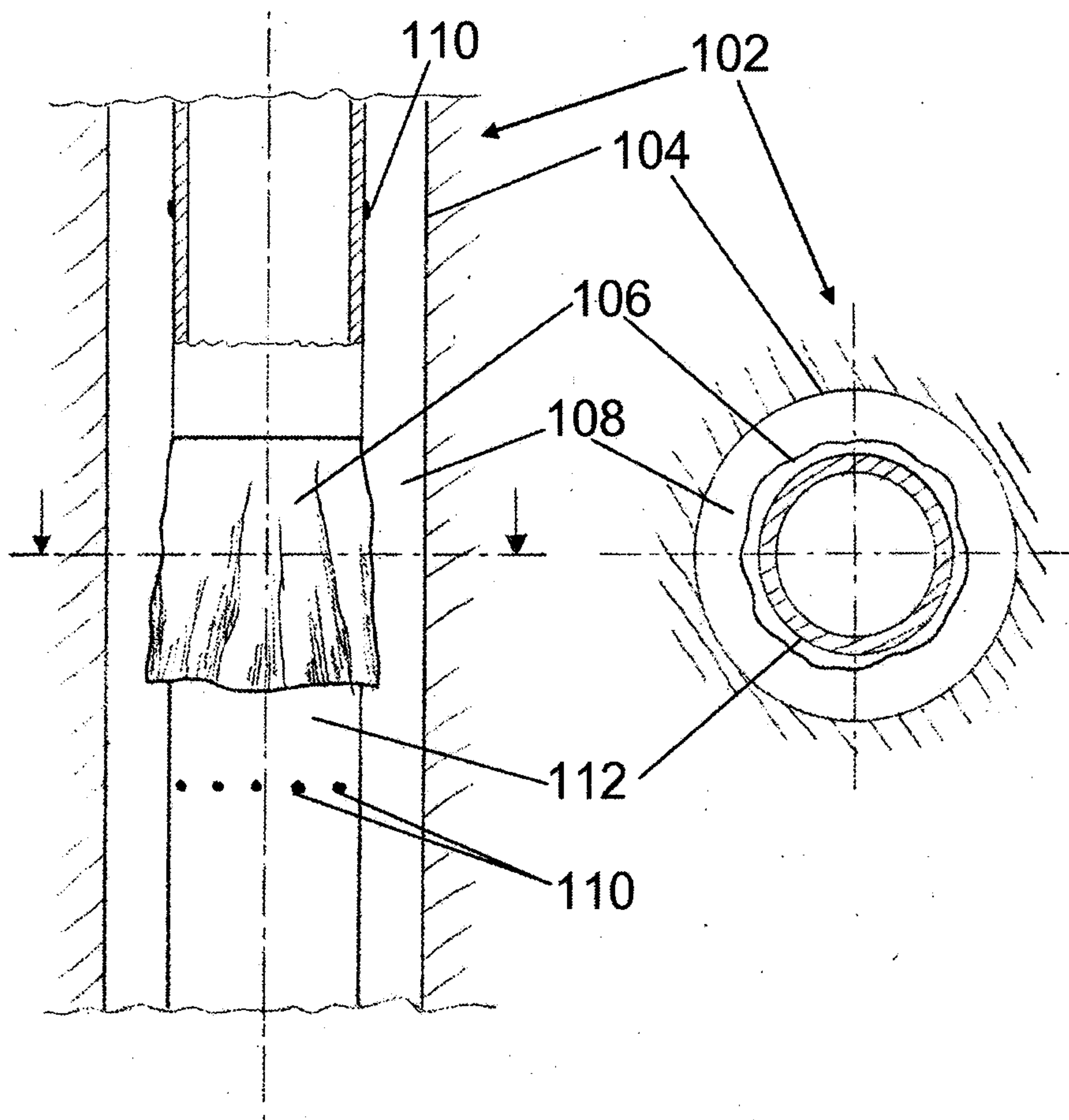

Fig. 1A

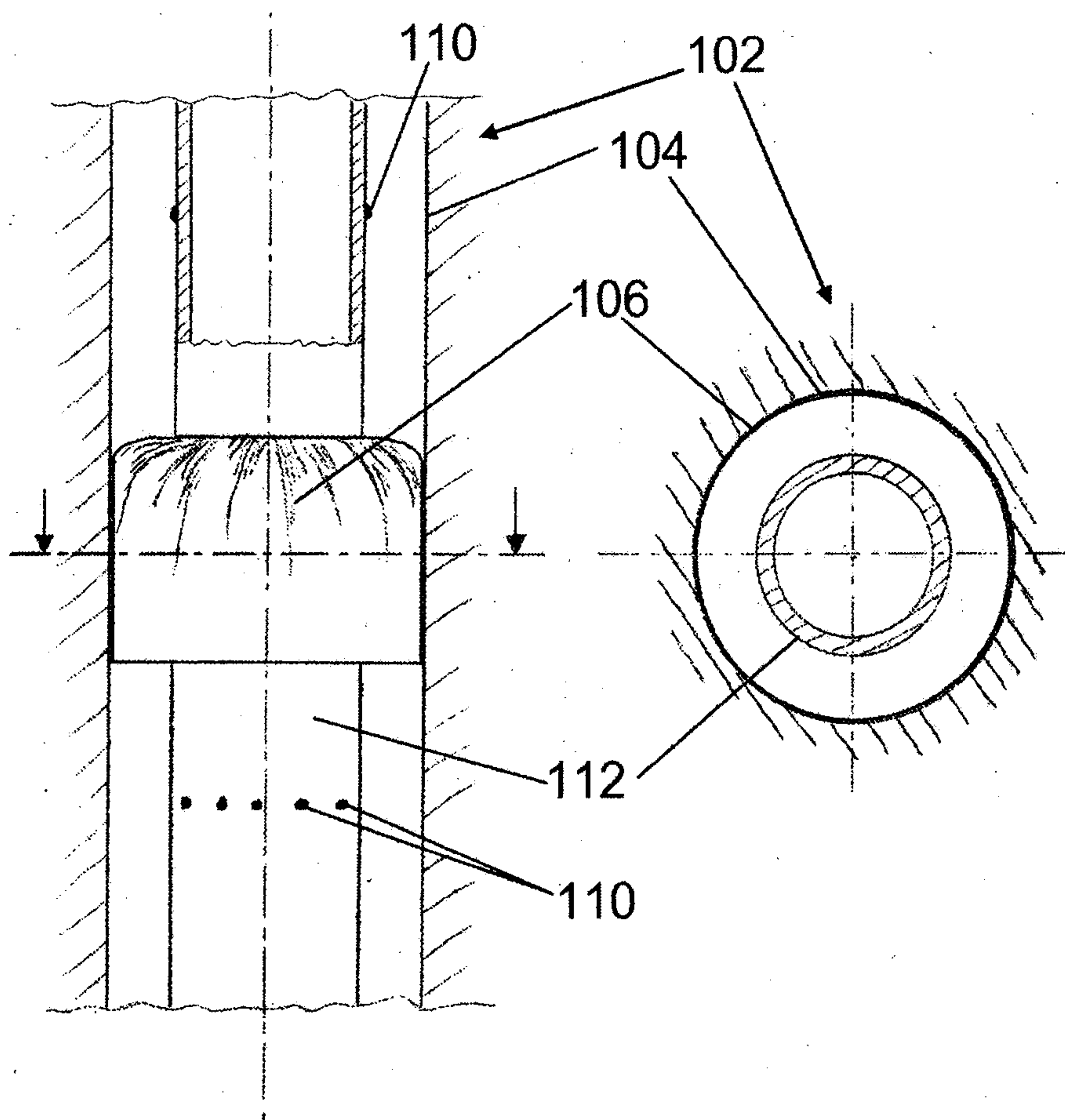

Fig. 1B

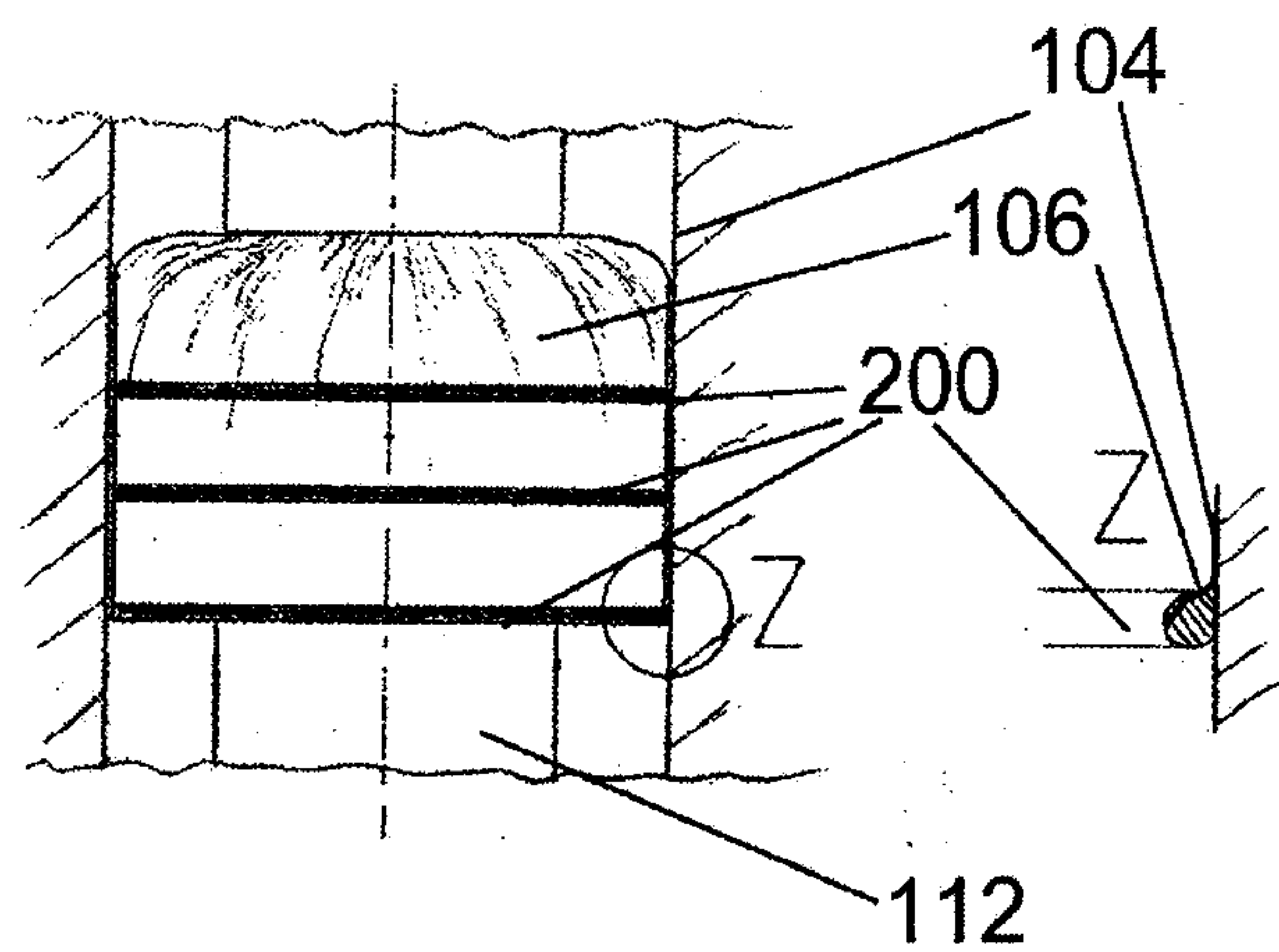

Fig. 2

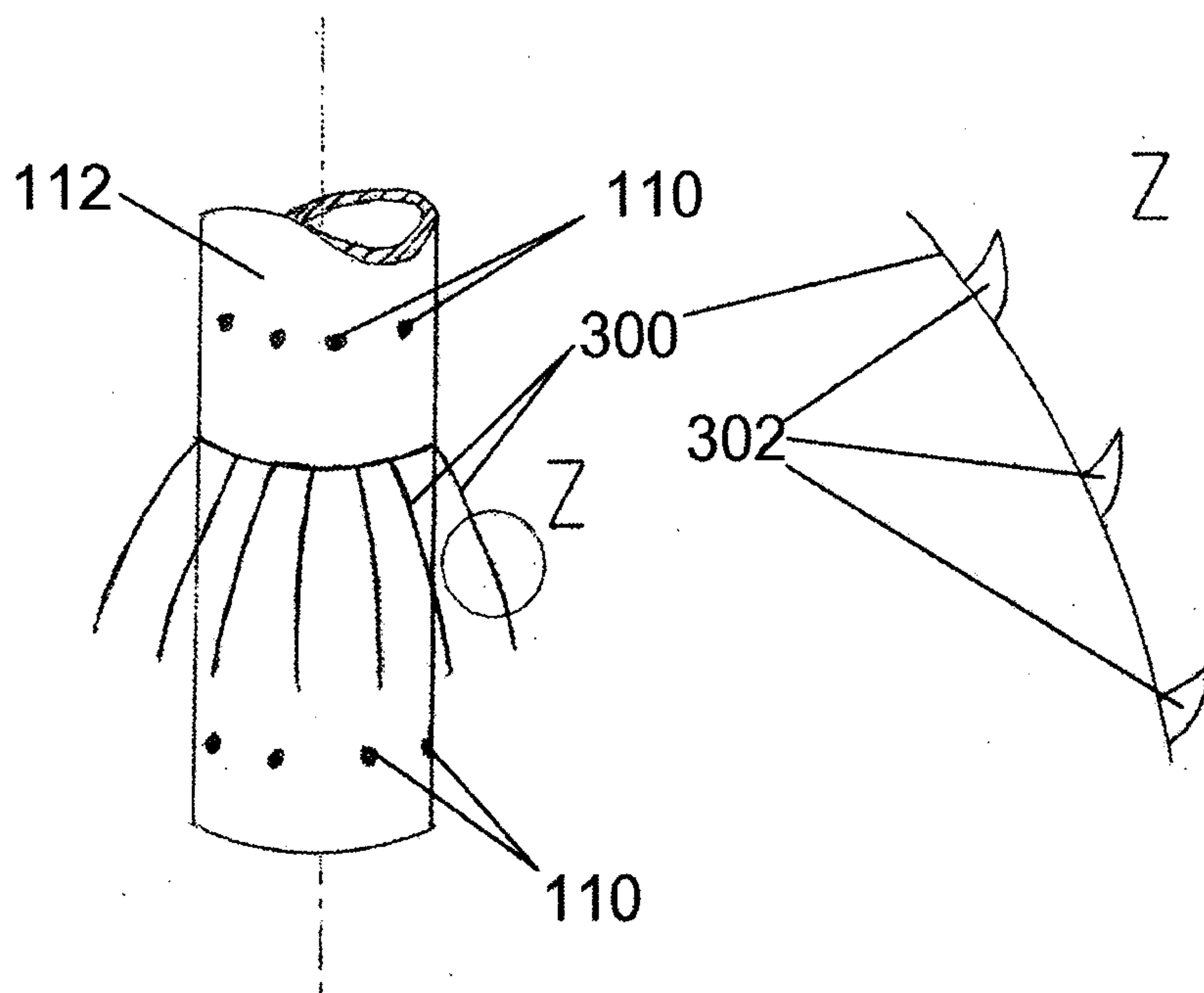

Fig. 3

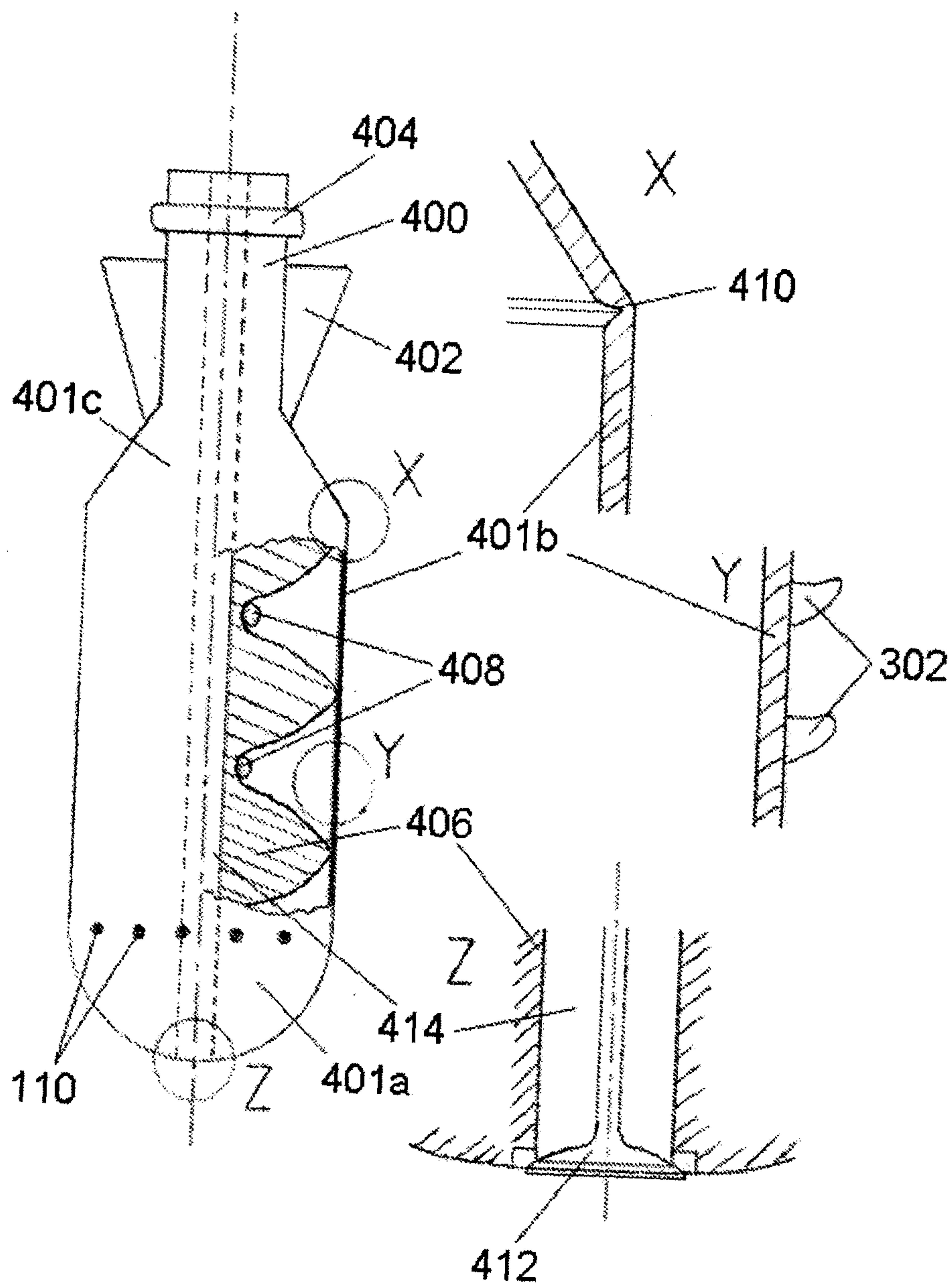

Fig. 4

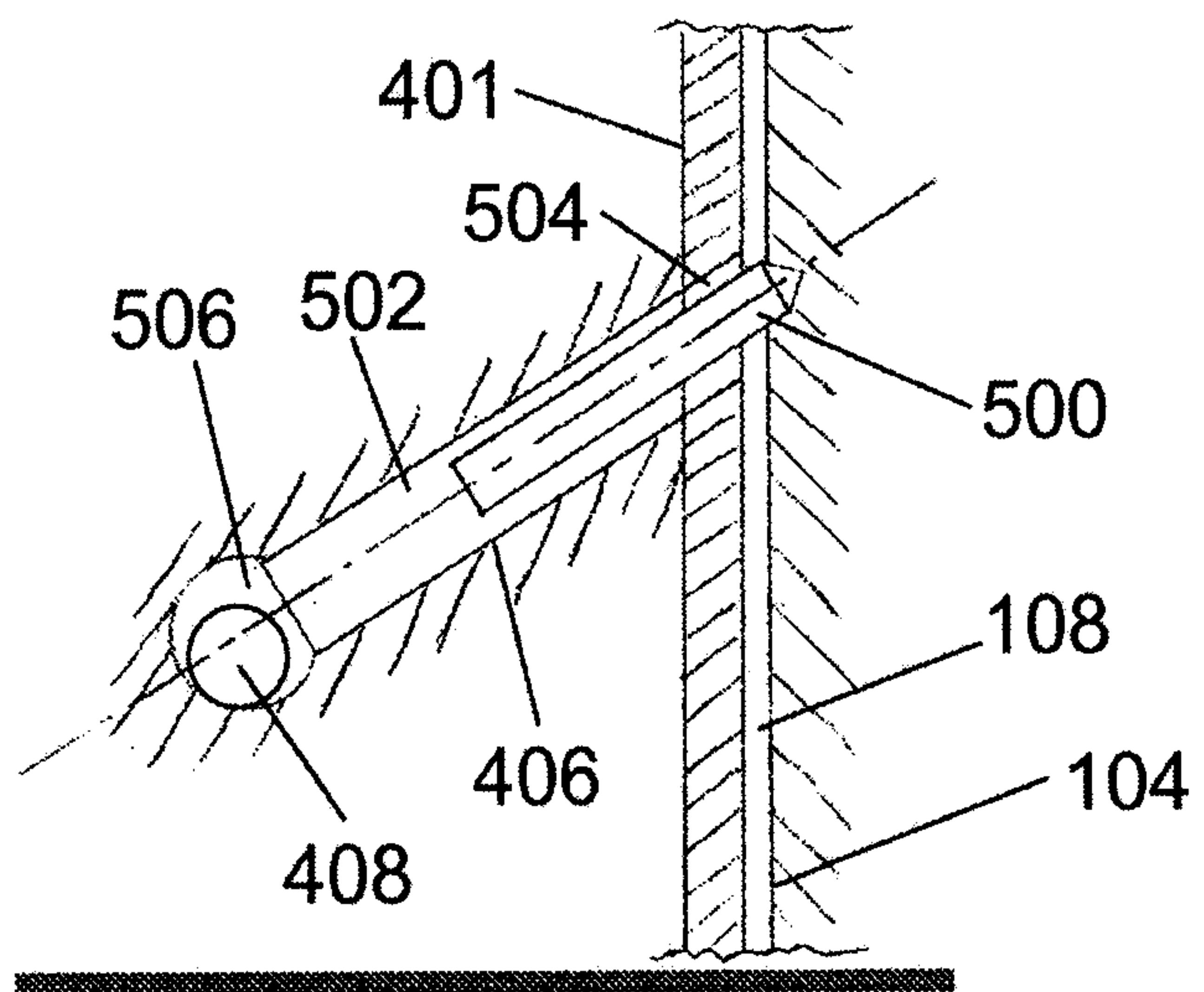

Fig. 5

