

[72] Inventors **Karl Vogtlin**
Villingen;
Norbert Helmschrott, Schwenningen, both
of Germany

[21] Appl. No. **23,336**

[22] Filed **Mar. 27, 1970**

[45] Patented **Nov. 30, 1971**

[73] Assignee **Kienzle Apparate GmbH**
Villingen, Germany

[32] Priority **Mar. 28, 1969**

[33] **Germany**

[31] **P 19 15 917.2**

[50] Field of Search..... 346/49,
 62-64, 7

[56] **References Cited**
UNITED STATES PATENTS

3,016,273 1/1962 Vogtlin et al. 346/62

3,228,032 1/1966 Zumkeller 346/62

Primary Examiner—Joseph W. Hartary
Attorney—Michael S. Striker

[54] **APPARATUS FOR MAKING ZIGZAG RECORDINGS OF DIFFERENT WIDTH**
14 Claims, 5 Drawing Figs.

[52] U.S. Cl..... 346/49,
 346/62

[51] Int. Cl..... G07c 5/06,
 G01d 9/28

ABSTRACT: Angularly spaced windings of a rotary armature are selectively energized by an astable multivibrator under the control of two selector switches correlated with two recording means so that the armature oscillates between different end positions and effects by a cam corresponding oscillations of the two recording means which record beam-shaped zigzag recordings of different width representing conditions selected by setting the selector switches to different selector positions.

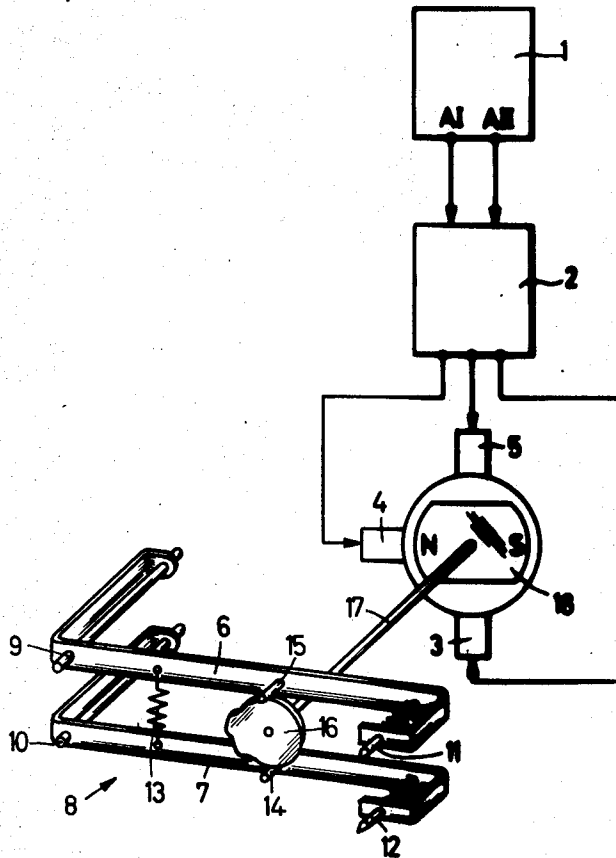

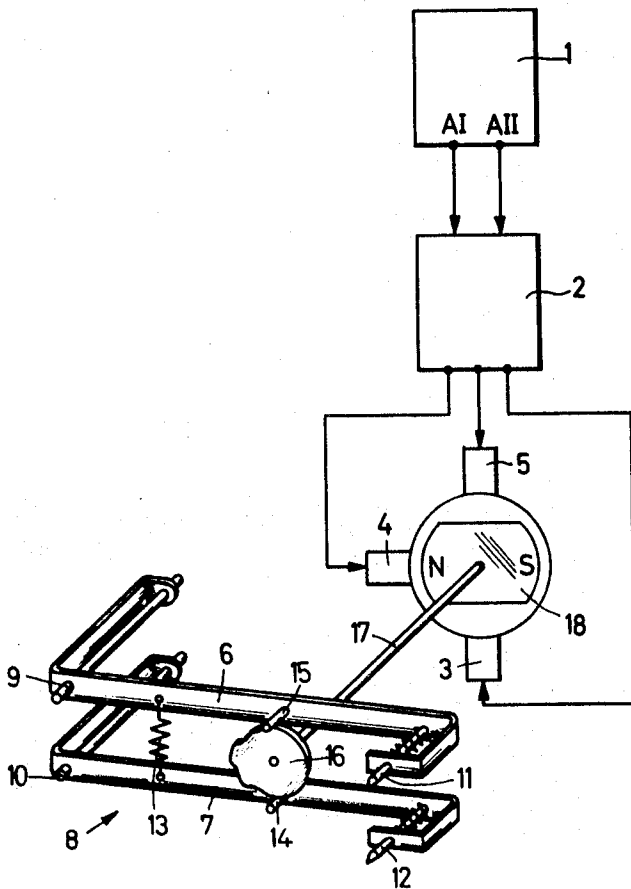

Fig.1

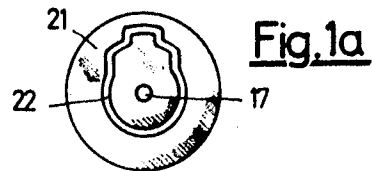

Fig.1a

Selection	I	II	Energization		Recording	
			AI	AII	Operator I	Operator II
A	P		3+4	↔ 4	~~~~~	_____
F	P		3	↔ 4	~~~~~	_____
P	A		4	↔ 4+5	_____	~~~~~
P	F		4	↔ 5	_____	~~~~~
A	A(F)		3+4	↔ 4+5	~~~~~	~~~~~
A	F		3+4	↔ 5	~~~~~	~~~~~
F	A		3	↔ 4+5	~~~~~	~~~~~

Fig.2

INVENTORS
 Karl Vöglin
 Norbert Helmschrott

by *Maxwell S. Heller*
 ATTORNEY

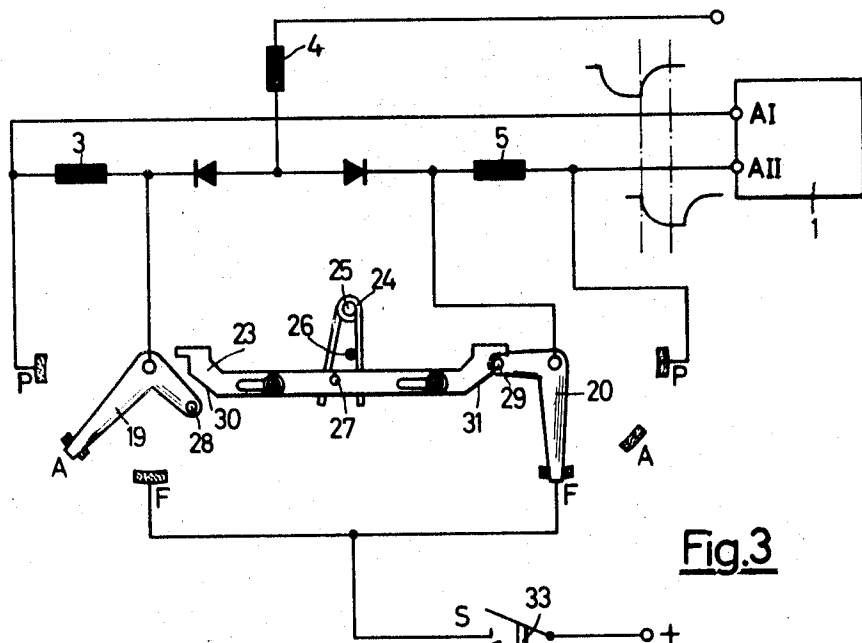

Fig.3

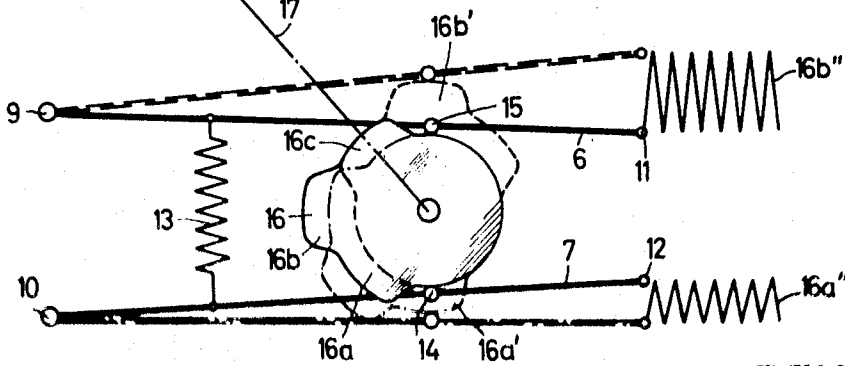
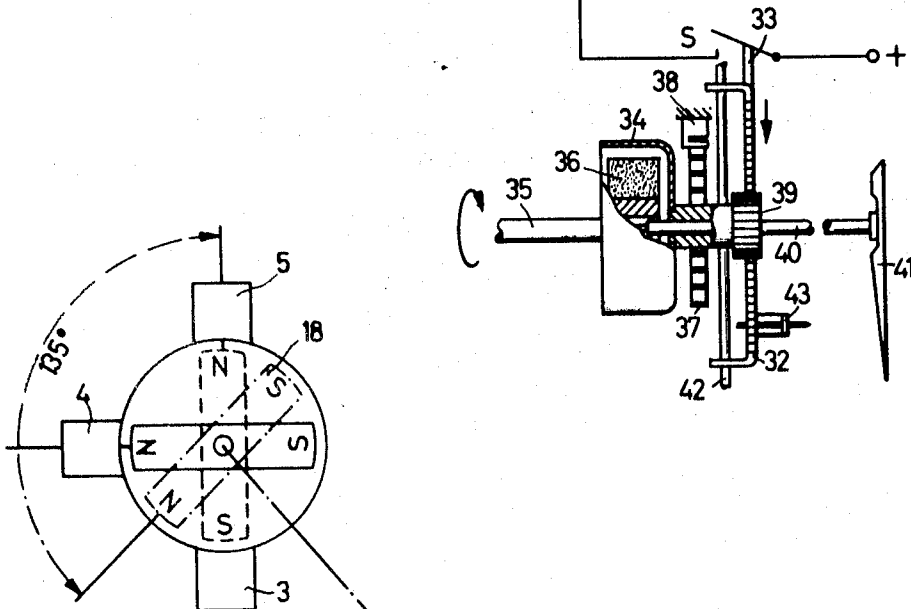

Fig.4

INVENTORS
Karl Vögtlin
Norbert Helmschrott

By [Signature]

APPARATUS FOR MAKING ZIGZAG RECORDINGS OF DIFFERENT WIDTH

BACKGROUND OF THE INVENTION

The present invention is concerned with apparatus for recording in the form of beam-shaped zigzag recordings of different width, the duration of different operational conditions, for example, the driving of a truck by one or the other of two alternate drivers, rest periods of the drivers, and time periods during which one or the other driver performs auxiliary functions, such as loading. The beam-shaped recordings are produced by oscillating recording members on a continuously rotating record carrier consisting of paper. When a recording member is not oscillated, a circular line is recorded instead of the circular beam-shaped recordings.

The time periods in which machines and trucks or other vehicles operate under specific conditions, can be advantageously represented by beam-shaped zigzag recordings of different amplitude and width. This is also true for time periods which substantially correspond to the standard working hours of a person working at the machine or vehicle. On the basis of the recording indicating the working time of the respective person, the payment is determined. Different operational conditions of the machine or vehicle, or different services of the operators of the machine or vehicle can be indicated by zigzag recordings of different amplitude forming beam-shaped recordings of different width. Zigzag recordings of this type can be automatically read out by readout apparatus and does not require the interpretation of the recording by a person.

In accordance with the prior art, the oscillation of the recording means may be mechanically produced by the oscillation of the moving vehicle or machine, or thermoelectric means including bimetal devices can be used. However, the mechanically oscillated recording means have the disadvantage that they depend on the energy of the oscillations of the machine or vehicle, so that the beam shape of the recording is not accurate. Thermoelectric devices require a great deal of space, and have a comparatively short span of life due to fatigue effects.

It is also known to oscillate the recording means by electromagnetic means, and to limit the width of the aim-shaped zigzag recording by a stop controlled by another magnet. The apparatus has the disadvantage that the additional stop magnet requires much space. Furthermore, since the force by which the armature of the magnet is operated depends on a hyperbolic function, the recording means is stopped with a considerable impact and tends to bend and rebound. Particularly due to the support of the recording member at one end, an overshooting is unavoidable due to which the width of the beam-shaped zigzag recording is not accurate. The error is not constant, but varies with the electric voltage applied to the electromagnets, and voltage fluctuations are substantial if the recording device is supplied by a voltage generated by apparatus driven by engine of a motor car.

It has been proposed to overcome this inaccuracy by connecting the recording means by an intermediate link with the drive magnet, and to control the recording means by the intermediate guide. However, this apparatus was not fully successful since, for reason of space, the intermediate guide link cannot be placed closely enough to the recording point so that a comparatively long free arm of the recording means carrying the recording point remains which tends to bend and overshoot when stopped in an end position. Also, it is not possible to eliminate play in the bearing of the recording means and in the guide means.

Another disadvantage of the recording apparatus using electromagnetically controlled stops is the loud noise created by the armature of the magnets, particularly due to the high frequency of the oscillations of the recording means required for making a beam-shaped zigzag diaphragm.

SUMMARY OF THE INVENTION

It is one object of the invention to overcome the disadvantages of known recording apparatus for making beam-shaped zigzag recordings of different width for indicating different operational conditions, and to provide an apparatus in which the amplitude of oscillation of recording means is exactly maintained, while noise is reduced to a minimum.

Another object of the invention is to provide an apparatus of this type which requires little space.

Another object of the invention is to provide apparatus for recording the working times, and also different functions of two operators of a motorcar in the form of two beam-shaped zigzag recordings, each of which is of different width depending on the type of work performed by the respective operators.

In accordance with the invention, a plurality of windings is spaced about a rotary armature which drives a cam by which the recording means is oscillated.

An embodiment of the invention comprises an impulse generator, for example an astable multivibrator; electromagnetic operating means including a rotary armature and a plurality of windings spaced about the armature; circuit means connecting the impulse generator with the windings, and including selector switch means having a plurality of selector positions for causing alternate energizing of different selected windings by the impulse generator so that the armature oscillates with different amplitudes between different end positions; and motion transmitting means, preferably including cam means, driven by the rotary armature and operatively connecting the same with oscillatory recording means which are also operated to oscillate at different amplitudes. Zigzag recordings of different width are thus recorded by the recording means when the selector switch means is set to different selector positions for indicating, for example, different types of services performed by the operator of a machine or motorcar.

In the preferred embodiment of the invention, the selector switch means include first and second selector switches which are respectively correlated with first and second recording members associated with first and second operators of a machine or motorcar. Each selector switch is set in accordance with the services to be performed by the respective operator, such as driving or accompanying the driver, and the varied width of the two beam-shaped recordings made by the two recording members indicates the durations of the various functions of each operator.

It is a particular advantage of the provision of a rotary armature controlled by a plurality of windings that a rotary armature is accelerated more at the beginning of its movement than at the end, in contrast to a reciprocating armature whose acceleration and speed is the greatest when stopped at the end of the amplitude of the oscillation. When the rotary armature is used in accordance with the invention, the torque exerted by the windings on the same becomes zero when the armature arrives in a position aligned with one of the windings. Consequently, the recording means moves slowly when arriving at the ends of the oscillatory movement, and comes to a stop without requiring mechanical stop means so that any noise produced by impact is avoided. The recording movements are directly limited by the magnetic fields of the windings, so that it is possible to use one or two cams driven by the armature for oscillating recording means at different amplitudes depending on the shape of the cam track, and on the location of the armature in the two end positions between which it is moved by the selectively energized and deenergized windings.

The novel features which are considered as characteristic for the invention are set forth in particular in the appended claims. The invention itself, however, both as to its construction and its method of operation, together with additional objects and advantages thereof, will be best understood from the following description of specific embodiments when read in connection with the accompanying drawings.

BRIEF DESCRIPTION OF THE DRAWING

FIG. 1 is a fragmentary schematic perspective view illustrating an embodiment of the invention;

FIG. 1a is a side elevation illustrating a modified cam which can be used in the embodiment FIG. 1;

FIG. 2 is a table illustrating coordinated selector positions of two selector switches associated with two different drivers, the correspondingly energized windings and the shape of two recordings respectively correlated with two drivers;

FIG. 3 is partly a diagram illustrating the electric circuit of the embodiment of FIG. 1, including two selector switches, interlocking means for the same and a speed-responsive switch operated by speed-responsive apparatus partially shown in section; and

FIG. 4 is a fragmentary schematic view illustrating operational conditions of the armature and cam means of the embodiment shown in FIGS. 1 and 3.

DESCRIPTION OF THE PREFERRED EMBODIMENTS

Referring first to FIGS. 1 and 3, an astable multivibrator 1 serves as impulse generator supplying alternate pulses from two outputs AI and AII. A circuit schematically indicated at 2 in FIG. 1 and shown in greater detail in FIG. 3, includes three windings 3, 4 and 5 angularly spaced along a circle and producing, when selectively energized under the control of selector switches 19 and 20, magnetic fields acting on a permanent magnet armature 18 for turning the same between angular positions. A shaft 17 connects armature 18 with a cam 16 whose annular cam track, best seen in FIG. 4, cooperates with cam follower pins 14 and 15 on two recording members 7 and 6 having U-shaped first ends supported on shafts 9 and 10 for oscillatory movement, and having U-shaped free ends carrying spring biased recording points. The recording means further include a spring 13 connecting the free arms of recording members 6 and 7 and biasing pins 15 and 14 toward the annular cam track of cam 16. Cam 16 may be replaced by a cam disc 21, shown in FIG. 1a, which has an annular cam groove 22 in one lateral face which can be engaged by follower pins corresponding to follower pins 15 and 16. When a cam 21 with an endless cam groove 22 is used, spring 13 can be omitted so that lesser friction prevails between the follower pins and the cam, reducing the load torque acting on the armature 18. When armature 18 is oscillated by selectively energized windings 3, 4 and 5, cam 16 or cam 21 is also oscillated, and causes oscillations of recording members 6 and 7 so that recording points 11 and 12 record on a continuously rotating circular paper disc, not shown.

Referring now to FIG. 3, windings 3, 4 and 5 are schematically shown. Windings 3 and 5 are connected in series with winding 4, and separated from the same by diodes. Two selector switches I and II are respectively associated with two operators of a car or machine, and each selector switch has three positions P, representing a rest period of the respective operator, A representing auxiliary services of the respective operator and F representing driving of the respective operator. Since both operators cannot drive simultaneously, locking means are provided which prevent the placing of both selector switches 19 and 20 in the position F representing driving.

Selector switch arms 19 and 20 are angular and have, respectively a contact arm, and a control arm carrying a pin 28 and a pin 29, respectively, which cooperate with slanted faces 30 and 31 of a locking slide 23, which is guided by pins passing through slots in locking slide 23 for movement between two end positions. Shoulders are provided at the ends of slide 23 cooperating with pins 28 and 29. Slide 23 carries a pin 27, cooperating with the arms of a spring 24 mounted on a stationary pin 25. If none of the two selector switch arms 19 and 20 is in the drive position F, locking slide 23 is held by spring 24 in a central position determined by a stop pin 26. In the illustrated position, locking slide 23 is locked by pin 22 engaging the transverse shoulder on the respective end of

locking slide 23 so that turning of selector switch arm 19 toward the drive position F is blocked by engagement between pin 28 and a slanted face 30. When switch arm 20 is turned to one of the positions A or P, the shoulder is released by pin 29, and locking slide 23 can be shifted upon engagement between pin 28 and the slanted face 30 when selector switch arm 19 is turned toward the drive position F.

The angular switch arms 19 and 20 on the one hand, and the contacts P on the other hand, are connected to the ends of windings 3 and 5 so that winding 3 is shunted when selector switch arm 19 engages contact P, and so that winding 5 is shunted when selector switch arm 20 is turned to engage contact P. The respective shunted windings 3 and 5 are deenergized and produce no electromagnetic field for turning armature 18.

Switch contacts F of selector switches I and II are connected to each other, and are connected by a switch S a voltage source to whose other terminal, the end of winding 4 is connected.

Switch S opens when the motorcar provided with the apparatus of the present invention moves at a predetermined low speed. A slide 32 is mounted on a guide rod 42 and has a projection 33 cooperating with the arm of switch S. A copper drum 34 houses a freely rotatable magnet 36 which is secured to a shaft 35 driven by a rotating part of the motorcar. Due to Eddy currents, an electromagnetic torque is exerted on drum 34 which is counteracted by spring 37 secured to a stationary bracket 38 and to the hub of a gear 39 which is secured to drum 34, gear 39 meshing with the rack bar on slide 32 which may carry a recording point 43. A pointer 41 is connected by a shaft 40 with gear 39 and drum 34. The speed-responsive device controlling S is well known and not an object of the invention.

Referring now to FIG. 4, the recording members 6 and 7 are schematically shown, together with recording points 11 and 12. Cam 16 has a peripheral cam track of which a portion extending over more than 180° is circular, while the remaining portion has two low cam lobes 16a and 16c having the same radial height, and an intermediate lobe 16b of greater height.

Cam 16 is shown in FIG. 4 in solid lines in a position on which the followers 14 and 15 are in contact with the circular cam track portion, so that spring 13 pulls both recording members 6 and 7 to a normal position in which recording points 11 and 12 would draw circular lines on a rotating record carrier disc. Cam 16 is further shown in another position shown in broken lines and in a third position shown in dash and dot lines. The angular displacement of cam 16 is effected by the rotary armature 18 which is connected by shaft 17 with cam 16.

The above-described apparatus can be used on a truck or other motorcar for recording the working periods and rest periods of two operators of the truck, and more particularly for recording the time periods which each operator drives, and which are used for performing auxiliary services such as accompanying the actually driving operator. However, both operators may perform auxiliary services, such as loading, unloading, repairs, change of tires, and the like, or one or both operators may rest while the truck is stopped.

OPERATION

Line 1 of FIG. 2 contains headings selection, windings and recordings respectively identifying columns. The second line indicates in the selection column, two subcolumns representing the positions of selector switches I and II. The second line in the second column identifies the two outputs AI and AII of the multivibrator 1, and the second line of the last column identifies two subcolumns to be correlated with operator I and operator II. The following seven lines represent in the first column the selector positions of selector switches I and II, in the second column the windings which are excited and energized, and in the last two subcolumns, the shape of the recordings made by the recording means 6, 11 and 7, 12 when

the selector switches I and II, are set to the selector positions shown in the two subcolumns of the first column.

Referring first to an operational condition in which only operator I is in the car, ready to perform services, selector switch I is set to the position A, and selector switch II is set to the position P. A pulse at the output AII of impulse generator 1 flows through contact P and switch arm 20 parallel to winding 5, deenergizing the same, while windings 3 and 4, which are connected in series, are energized by the next following pulse at the output AI of impulse generator 1. Consequently, if the magnetic field of windings 3 and 4 turns the armature 18 45° in counterclockwise direction to a position located between windings 3 and 4. The next following pulse from output AII, energizes winding 5 so that armature 18 is turned back to the initial position aligned with winding 4. As long as selector switches I and II remain in the selected position, cam 16 is oscillated 45° between the normal position shown in solid lines, and the position shown in chain lines in which cam lobe 16a in the position 16a' is effective to displace recording member 7 out of the normal position in which follower 14 engages a circular cam track portion to the position shown in chain lines so that a zigzag recording 16 a'' is made. At the same time, follower 15 of recording member 6 remains in contact with the circular cam track portion, and a circular line is drawn on the rotating record carrier, as shown, in the respective line of the table of FIG. 2, in the column associated with operator II.

If operator I knows at the beginning of his working time, that he is to be the first driver, he places his selector switch I in the position in which contact arm 19 engages contact F associated with driving. Nevertheless, the recordings are made as before, since the speed-responsive switch S is open due to the fact that the motorcar does not move. When operator I now starts the car, the speed-responsive device acting on switch S closes the same so that the pulses transmitted from output AI bypass winding 4 so that winding 3 is energized by pulses from output AI, and winding 4 is energized by pulses from output AII so that armature 18 oscillates an angle of 90° between positions aligned with winding 3 and winding 4, respectively. When armature 18 turns cam 16 from the normal position shown in solid lines 90° to a position not shown, in which the high lobe 16b engages follower 14, writing point 13 is oscillated for a greater amplitude, so that a wider beam-shaped zigzag recording shown in FIG. 2 in the column of operator I is made, indicating that this operator drives as long as the wide zigzag recording is made.

In the following two lines of table 2, reversed operational conditions are illustrated in which operator I rests or is not present, while operator either waits or drives. In the first condition, windings 4, and windings 4 and 5 together are respectively energized when the pulses AI and AII are transmitted so that a narrow zigzag recording is made as shown in the sub-column associated with operator II. When this operator drives, windings 4 and 5 are energized, and armature 18 is turned 90° in clockwise direction, whereby the high lobe 16b in the position 16b' shown in broken lines in FIG. 4, effects the recording of a wide beam-shaped zigzag recording 16b'', as shown in FIGS. 2 and 4.

When both operators are present, it can be assumed that one operator, for example II, sets his associated selector switch II to a position in which contact arm 20 engages contact F. The other operator I cannot set his correlated switch I to the position F since this is prevented by the locking slide 23, as explained above.

As long as the car is at a standstill, an impulse from output AI energizes windings 3 and 4, and the next following pulse from output AII flows through windings 4 and 5 to the plus terminal of the voltage source. Consequently, armature 18 oscillates between two end positions, one of which is located between windings 3 and 4, and the other of which is located between windings 4 and 5. The oscillation angle is 90°, but cam lobes 16a and 16c alternately act on followers 14 and 15 of recording members 6 and 7 so that recording points 11 and

12 oscillate at a small amplitude and make two beam-shaped recordings of small width as shown in FIG. 2 in the columns of operators I and II, to indicate that both operators are at work, although none of the same actually drives.

When one of the operators, for example operator II starts the car, and the same begins to move, the speed-responsive switch S is closed so that winding 4 is shunted for the impulses from output AII so that the armature oscillates between a first end position between windings 3 and 4 and a second end position aligned with winding 5. In this manner, armature 18 oscillates an angle of 135°, as schematically indicated in the upper portion of FIG. 4, and cam 16 is oscillated the same angle so that in the position of cam 16 shown in broken lines, the high cam lobe 16b in the position 16b' is effective to oscillate recording member 6 so that a wide beam-shaped zigzag recording 16b'' is made, while recording member 7 is operated by lobe 16a in the position 16a' to make a narrower beam-shaped zigzag recording, as shown in the column of operator I in FIG. 2.

The reversed operational conditions, in which operator I drives and his selector switch is in the position in which switch arm 19 engages contact F, while selector switch II is in the position in which switch 20 engages contact A, causes alternate energization of winding 3 and windings 4 and 5, so that a wide zigzag recording is made by recording means 7, 12 for operator I, and a narrow zigzag recording is made by recording means 6, 11 for operator II, as shown in the last line of FIG. 2.

The apparatus of the invention permits the control of two recording members 6 and 7 by three windings 3, 4 and 5 in such a manner that each recording member is capable of making two different beam-shaped zigzag recordings, which required in the prior art at least four electromagnets. Furthermore, the provision of a rotary armature 6 saves a great deal of space, and the direct mounting of the cam 16 on the shaft 17 of armature 18, eliminates the play of other transmissions which otherwise have to be finished to very high tolerances. The accuracy of the zigzag recordings depends only on the precision of the cam 16. Since the end positions of the recording members 6 and 7 are not determined by stops, any noise produced by impacts is eliminated, and overshooting of the armature does not occur since the magnetic torque is gradually reduced as the armature moves to its respective end positions.

It is advantageous to provide electrical damping means by which the rising and descending gradients of the pulses supplied by impulse generator 1 are extended. It is also advantageous to control the generation of pulses at outputs AI and AII, so that the rising and descending periods of the pulses overlap, and the armature creeps in the region of its end positions.

It will be understood that each of the elements described above, or two or more together, may also find a useful application in other types of recording apparatus, differing from the types described above.

While the invention has been illustrated and described as embodied in apparatus for making beam-shaped zigzag recordings of different width for indicating different operational conditions, it is not intended to be limited to the details shown, since various modifications and structural changes may be made without departing in any way from the spirit of the present invention.

Without further analysis, the foregoing will so fully reveal the gist of the present invention that others can by applying current knowledge readily adapt it for various applications without omitting features, that, from the standpoint of prior art, fairly constitute essential characteristics of the generic or specific aspects of this invention and, therefore, such adaptations should and are intended to be comprehended within the meaning and range of equivalence of the following claims.

What is claimed as new and desired to be protected by Letters Patent is set forth in the appended claims.

I claim:

1. Apparatus for making zigzag recordings of different width, comprising, in combination, impulse generator means; electromagnetic operating means including a rotary armature and a plurality of windings spaced about said armature; circuit means connecting said impulse generator means with said windings, and including selector switch means having a plurality of selector positions for causing alternate energizing of different selected windings by said impulse generator means so that said armature oscillates with different amplitudes between different end positions; recording means mounted for oscillation; and motion-transmitting means driven by said armature and operatively connecting the same with said recording means for oscillating the said recording means different amplitudes so that zigzag recordings of different width are recorder when said selector switch means is set to different selector positions.

2. Apparatus as claimed in claim 1 wherein said impulse generator means has two outputs and alternately generates first and second pulses at said outlets; and wherein said circuit means connects said windings so that said first pulses energize at least one predetermined winding to turn said armature from a normal position to one of said end positions according to the position of said selector switch means, and so that said second pulses energize at least one predetermined winding to return said armature to said normal position.

3. Apparatus as claimed in claim 1 wherein said motion-transmitting means include rotary cam means connected with said armature for oscillation therewith and cooperating with said recording means for angularly displacing the same, said cam means having portions of different height for oscillating said recording means different amplitudes so that zigzag recordings of different width are recorded.

4. Apparatus as claimed in claim 1 wherein said recording means includes first and second recording members mounted for oscillation about parallel axes; and wherein said selector switch means includes first and second selector switches respectively correlated with said first and second recording members, each selector switch having a plurality of selector positions and being independently settable to the same for causing energization of different selected windings so that zigzag recordings of different width can be simultaneously recorded by said first and second recording members.

5. Apparatus as claimed in claim 4 wherein said motion-transmitting means include a rotary cam connected with said armature for oscillation therewith, and having a cam track cooperating with said first and second recording members for simultaneously oscillating the same different amplitudes.

6. Apparatus as claimed in claim 5 wherein said impulse generator means has two outputs and alternately generates first and second pulses at said outlets; and wherein said circuit means connects said windings so that said first pulses energize at least one predetermined winding to turn said armature from a normal position to one of said end positions according to the positions of said selector switches so as to cause turning of said cam means in one direction of rotation, and so that said second pulses energize at least one predetermined winding to cause turning of said armature from said end positions back to said normal position whereby said cam means turns in the opposite direction of rotation and oscillates in synchronism with

the generation of said first and second pulses.

7. Apparatus as claimed in claim 6 wherein said cam means includes a cam disc having at least on one side an endless cam groove; and wherein said recording members have portions guided in said cam groove.

8. Apparatus as claimed in claim 6 wherein said circuit means includes conductors connected in parallel with selected windings of said plurality of windings when said first and second selector switches are in predetermined selector positions so that the respective windings are deenergized and do not influence the angular positions of said armature and said cam means.

9. Apparatus as claimed in claim 8 wherein said plurality of winding has three windings, two of said windings being connected in series with the third winding, and being said selected windings, parallel to which said conductors are connected by said first and second selector switches, respectively, in said predetermined selector positions of the same.

10. Apparatus as claimed in claim 9 wherein said third winding is spaced from said two windings angles of 90°, respectively, wherein said two windings are spaced from each other an angle of 180°, wherein said windings are disposed along a circle, and wherein said armature is a permanent magnet extending diametrically to said circle and turnable about the center of the same.

11. Apparatus as claimed in claim 6 wherein said impulse generator means is an astable multivibrator having two outputs connected by said circuit means with said windings.

12. Apparatus as claimed in claim 1 wherein said circuit means includes a speed-responsive switch having open and closed positions and effecting in said open and closed positions the energization of different windings of said plurality of windings so that said armature moves between different end positions and zigzag recordings made in said open and closed positions of said speed responsive switch have different width for indicating different operational conditions in which the apparatus moves and is stopped, respectively.

13. Apparatus as claimed in claim 1 wherein said selector positions of said selector switch means include a first position for effecting energization of at least one winding, a second position for effecting energization of at least one other winding, and a third position for effecting simultaneous energization of two windings of said plurality of windings.

14. Apparatus as claimed in claim 1 wherein said recording means includes first and second recording members mounted for oscillation about parallel axes; wherein said selector switch means includes first and second selector switches respectively correlated with said first and second recording members, each selector switch having a plurality of selector positions and being independently settable to the same for causing energization of different selected windings so that zigzag recordings of different width can be simultaneously recorded by said first and second recording members, wherein each of said selector switches has a predetermined selector position representing a predetermined operational condition; and comprising locking means interlocking said selector switches so that only one of the same can be placed at any time in said predetermined selector position thereof.

* * * * *