



(86) Date de dépôt PCT/PCT Filing Date: 2016/02/08
 (87) Date publication PCT/PCT Publication Date: 2016/08/25
 (85) Entrée phase nationale/National Entry: 2017/07/21
 (86) N° demande PCT/PCT Application No.: BE 2016/000012
 (87) N° publication PCT/PCT Publication No.: 2016/131113
 (30) Priorité/Priority: 2015/02/10 (BE2015/5067)

(51) Cl.Int./Int.Cl. *B65D 1/16* (2006.01),
B32B 1/02 (2006.01), *B65D 1/02* (2006.01),
B65D 1/48 (2006.01), *B65D 23/08* (2006.01)
 (71) Demandeur/Applicant:
 CARDIFF GROUP, NAAMLOZE VENNOOTSCHAP, BE
 (72) Inventeurs/Inventors:
 STANDAERT, GEERT NORBERT R., BE;
 VANDEBRIEL, IMAR, BE
 (74) Agent: GOWLING WLG (CANADA) LLP

(54) Titre : FUT POUR BOISSONS CONTENANT DU CO2 ET UTILISATION DUDIT FUT
 (54) Title: BARREL FOR CO2-CONTAINING DRINKS AND USE THEREOF

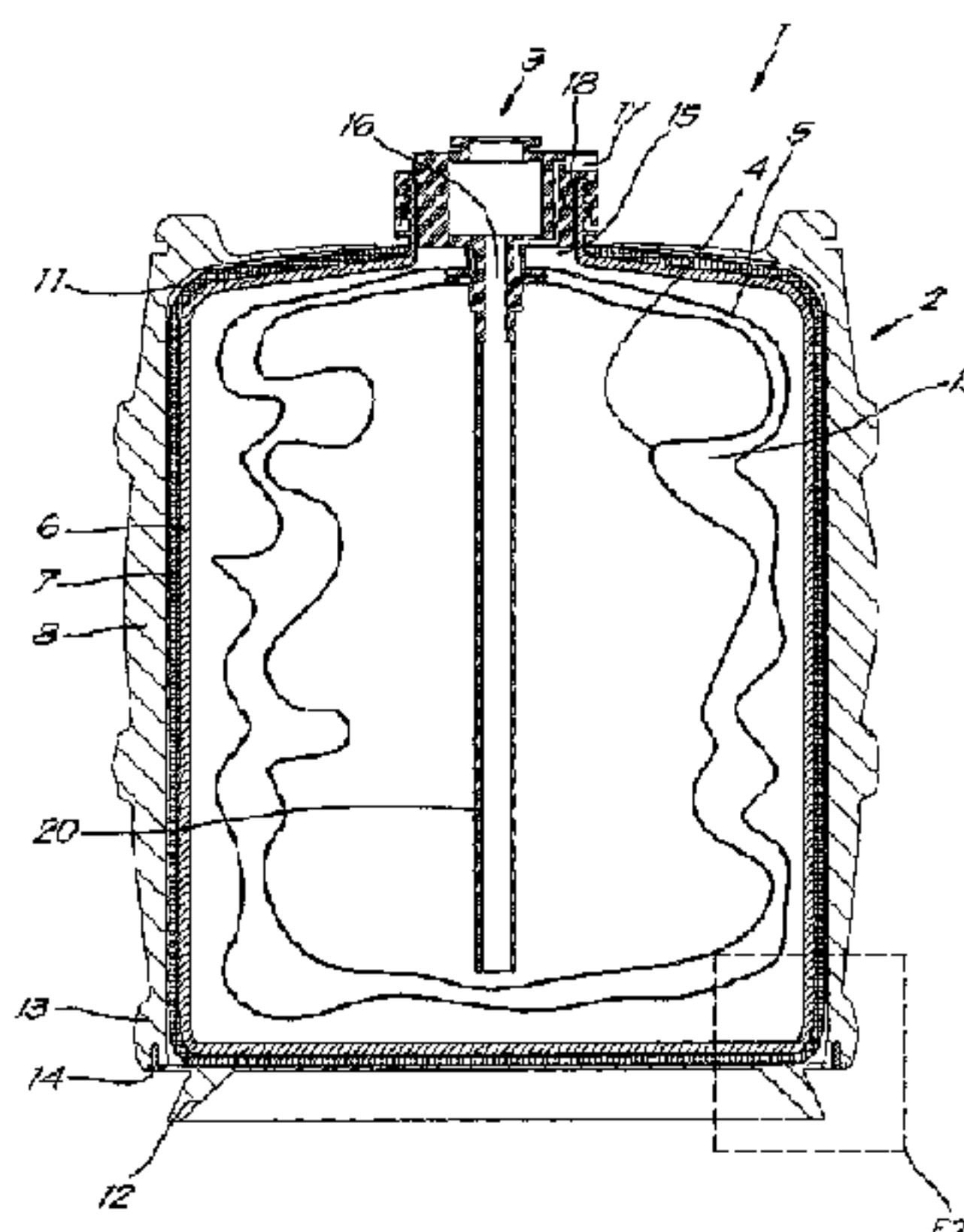


Fig. 1

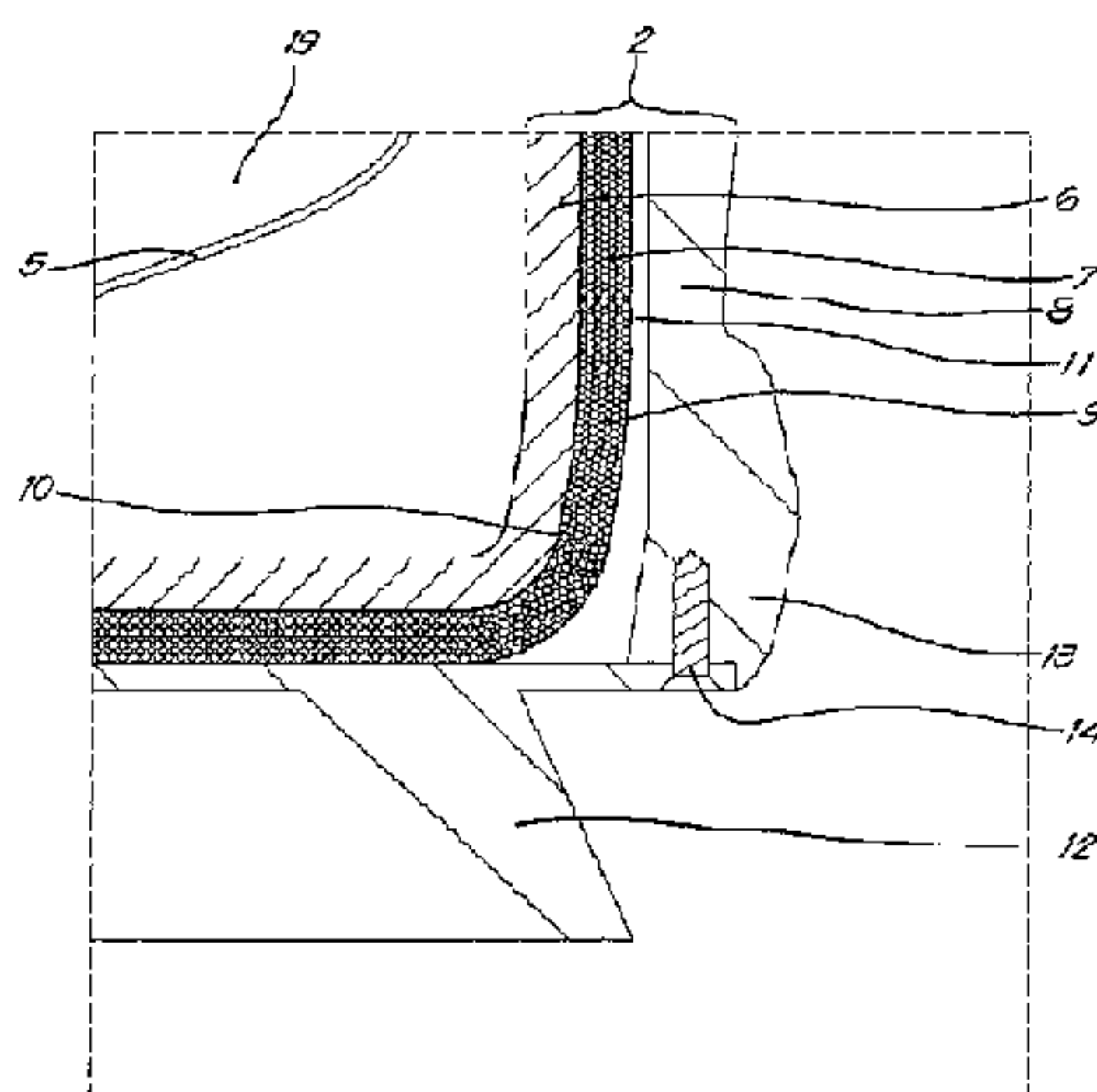


Fig. 2

(57) **Abrégé/Abstract:**

Barrel for CO₂-containing drinks, whereby the barrel comprises a rigid holder that comprises at least two layers, i.e. a first layer that is made of a polymer and a second, fibre-reinforced, layer, whereby the second layer is outside the first layer and whereby the second layer is attached to the first layer.

(12) INTERNATIONAL APPLICATION PUBLISHED UNDER THE PATENT COOPERATION TREATY (PCT)

(19) World Intellectual Property
Organization
International Bureau(10) International Publication Number
WO 2016/131113 A4(43) International Publication Date
25 August 2016 (25.08.2016)

(51) International Patent Classification:

B32B 5/02 (2006.01) **B65D 23/08** (2006.01)
B32B 5/28 (2006.01) **B65D 77/04** (2006.01)
B32B 7/00 (2006.01) **B65D 1/02** (2006.01)
B32B 27/12 (2006.01) **B65D 1/48** (2006.01)
B32B 27/32 (2006.01) **B65D 3/22** (2006.01)
B32B 1/02 (2006.01) **B65D 3/24** (2006.01)
B65D 8/00 (2006.01) **B65D 77/06** (2006.01)
B65D 1/16 (2006.01) **B65D 83/00** (2006.01)

(21) International Application Number:

PCT/BE2016/000012

(22) International Filing Date:

8 February 2016 (08.02.2016)

(25) Filing Language:

Dutch

(26) Publication Language:

English

(30) Priority Data:

2015/5067 10 February 2015 (10.02.2015) BE

(71) Applicant: **CARDIFF GROUP, NAAMLOZE VEN-
NOOTSCHAP** [BE/BE]; Bruinstraat 70, 3520 Zonhoven
(BE).(72) Inventors: **STANDAERT, Geert Norbert R.**; Bruinstraat
70, 3520 Zonhoven (BE). **VANDEBRIEL, Imar**; Heikant-
dreef 1, 3940 Hechtel (BE).(74) Agent: **VAN VARENBERG Patrick**; Bureau M.F.J.
Bockstael nv., Arenbergstraat 13, 2000 Antwerpen (BE).(81) Designated States (*unless otherwise indicated, for every
kind of national protection available*): AE, AG, AL, AM,
AO, AT, AU, AZ, BA, BB, BG, BH, BN, BR, BW, BY,

[Continued on next page]

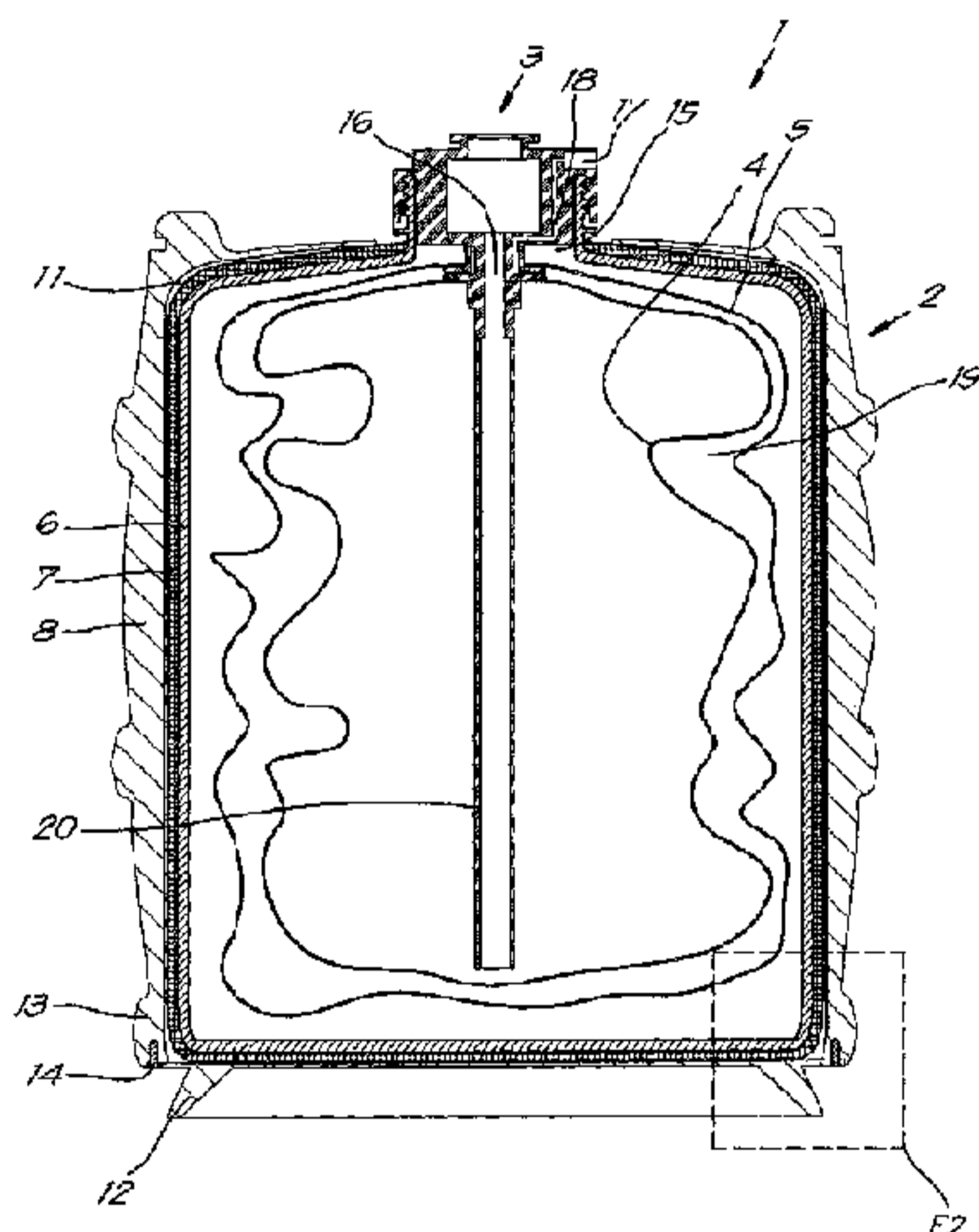
(54) Title: BARREL FOR CO₂-CONTAINING DRINKS AND USE THEREOF

Fig. 1

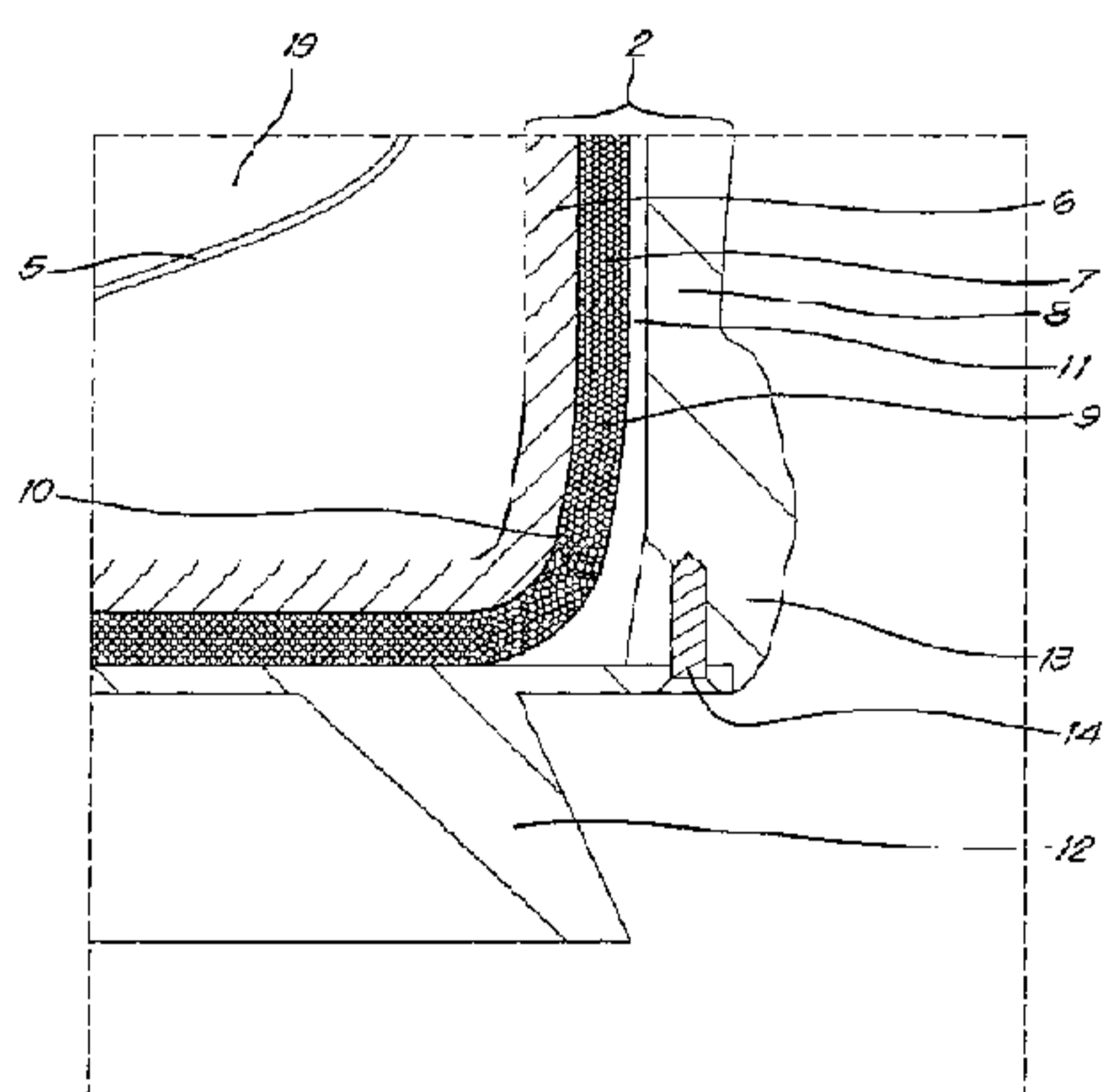


Fig. 2

(57) **Abstract:** Barrel for CO₂-containing drinks, whereby the barrel comprises a rigid holder that comprises at least two layers, i.e. a first layer that is made of a polymer and a second, fibre-reinforced, layer, whereby the second layer is outside the first layer and whereby the second layer is attached to the first layer.



WO 2016/131113 A4

WO 2016/131113 A4

BZ, CA, CH, CL, CN, CO, CR, CU, CZ, DE, DK, DM, DO, DZ, EC, EE, EG, ES, FI, GB, GD, GE, GH, GM, GT, HN, HR, HU, ID, IL, IN, IR, IS, JP, KE, KG, KN, KP, KR, KZ, LA, LC, LK, LR, LS, LU, LY, MA, MD, ME, MG, MK, MN, MW, MX, MY, MZ, NA, NG, NI, NO, NZ, OM, PA, PE, PG, PH, PL, PT, QA, RO, RS, RU, RW, SA, SC, SD, SE, SG, SK, SL, SM, ST, SV, SY, TH, TJ, TM, TN, TR, TT, TZ, UA, UG, US, UZ, VC, VN, ZA, ZM, ZW.

(84) Designated States (*unless otherwise indicated, for every kind of regional protection available*): ARIPO (BW, GH, GM, KE, LR, LS, MW, MZ, NA, RW, SD, SL, ST, SZ, TZ, UG, ZM, ZW), Eurasian (AM, AZ, BY, KG, KZ, RU, TJ, TM), European (AL, AT, BE, BG, CH, CY, CZ, DE, DK, EE, ES, FI, FR, GB, GR, HR, HU, IE, IS, IT, LT, LU, LV, MC, MK, MT, NL, NO, PL, PT, RO, RS, SE,

SI, SK, SM, TR), OAPI (BF, BJ, CF, CG, CI, CM, GA, GN, GQ, GW, KM, ML, MR, NE, SN, TD, TG).

Declarations under Rule 4.17:

- *as to applicant's entitlement to apply for and be granted a patent (Rule 4.17(ii))*
- *of inventorship (Rule 4.17(iv))*

Published:

- *with international search report (Art. 21(3))*
- *with amended claims (Art. 19(1))*

(88) Date of publication of the international search report:

5 January 2017

Date of publication of the amended claims:

9 March 2017

Barrel for CO₂-containing drinks and use thereof.

The present invention relates to a barrel for CO₂-
5 containing drinks and the use thereof.

More specifically the invention relates to a barrel or keg
for beer, in which the beer can be placed under pressure
and from which the beer can be dispensed.

10

Such a beer barrel must satisfy a number of technical
requirements. Firstly the beer must be well separated from
the outside air in order to prevent CO₂ being able to
escape from the beer whereby the flavour of the beer would
15 change, and also to prevent oxygen from the air being able
to get into the beer, because this too can detrimentally
affect the flavour to a great extent. For example,
depending on the type, even an oxygen content of 1000 ppb
(parts per billion) can be harmful for the flavour.

20

Such a separation from the outside air is important both
before the beer is used for the first time and after a part
of the beer has already been tapped off, but a proportion
to be used in the future is still present in the barrel.

25

The extent to which a beer barrel satisfies these technical
requirements depends on the gas permeability of the various
walls that are used in the beer keg, whereby walls with a
higher diffusion barrier in general cost more because they
30 are thicker or made of a more expensive material.

Secondly, the holder has a mechanical function, i.e. to resist the internal pressure, without deformation or damage, that is necessary to dispense the foodstuff out of the holder.

5

This pressure can be high, certainly in barrels in which the pressure medium, for example CO₂, for driving out the beer is already present when these barrels are in a warm environment, which can easily happen during the transport
10 of the filled barrels. In certain conditions this pressure can amount to 10 bar. It must also be considered that such barrels can fall during transport, and can thereby be exposed to high forces from the outside.

15 It goes without saying that such beer kegs must be constructed as cheaply as possible, such that current metal barrels are considered too expensive and heavy, certainly in cases where the transport distance is relatively long and/or good coordination of the supply chain is lacking,
20 such that reuse is difficult.

Beer barrels of polypropylene or polyethylene are known. However they have a limited resistance to high pressure, so that at higher pressures in particular they must be
25 constructed with very thick walls.

Also during use, the pressure resistance falls quickly, because with every significant change in pressure, such as during a temporary higher temperature for example, as
30 mentioned above, but also the repressurisation for reuse, a partially elastic and partially irreversible plastic

deformation occurs that can lead to risky weak spots after reuse a few times.

5 These materials are also relatively permeable to CO₂ and oxygen, so that special measures have to be taken to screen off the beer.

10 Currently no beer barrels are known that are cheap, have good CO₂ and oxygen protection, are resistant to high pressures, and can also be recycled dozens of times.

15 The purpose of the present invention is to provide a solution to the aforementioned and other disadvantages by providing a barrel for CO₂-containing drinks, whereby the barrel comprises a rigid holder that comprises at least two layers, i.e. a first layer that is made of a polymer and a second, fibre-reinforced, layer, whereby the second layer is outside the first layer and whereby the second layer is attached to the first layer.

20

Such a barrel is cheap to produce and is highly suitable for resisting high pressures.

25 Thanks to the second layer, which cannot expand, and the good attachment between the first and second layer, plastic deformation of the first layer does not occur, so that the barrel can be reused repeatedly. Hereby the second layer can be affixed over the entire first layer, but the second layer can also be an incomplete second layer that is only
30 affixed in places where the risk of rupture is the greatest.

In a preferred embodiment the barrel also comprises a flexible holder that is inside the rigid holder.

5 Preferably the rigid holder comprises a first outlet and the flexible holder comprises a second outlet, whereby the second outlet is provided with a connecting piece that is connected to the first outlet, and whereby the connecting piece is also provided with a tap or a connection for a
10 tap.

The flexible holder can now be filled with a CO₂-containing drink, and the space between the rigid holder and the flexible holder with a pressure medium, so that due to the
15 compression of the flexible holder the drink can be driven out of the barrel.

In another preferred embodiment the barrel is provided with a barrier layer to prevent the diffusion of oxygen from the
20 outside to the inside and the diffusion of CO₂ from the inside to the outside.

This can be done by providing the first or second layer, or the interface between the two, with a barrier layer, for
25 example a thin metal layer.

As is known from WO 2012/167333, for example, this can be done by using two flexible holders placed in one another, whereby the inner flexible holder is intended to contain
30 the drink and the outer flexible holder is intended to be pushed against the inside of the rigid holder by the

pressure medium, and as a result reduces the permeability of the rigid holder for the pressure medium, and whereby one or both of these flexible holders are made of a barrier material for CO₂ and oxygen.

5

In a further preferred embodiment the first layer is essentially made of an injection-mouldable polymer, preferably polyethylene that can be both HDPE and LDPE, or polypropylene. As a result this first layer is cheap to produce by means of injection moulding.

10

Furthermore, the said plastics have the advantage that even if the pressure rises higher than what the barrel can deal with, the barrel will not explode, but will plastically deform and tear locally, so that the pressure is reduced in a relatively controlled way so that a potentially hazardous explosion is prevented.

15

In a preferred embodiment the second layer is provided with one or more reinforcing fibres that are wound around the first layer. This means that the reinforcing fibres concerned each run completely around the barrel at least once.

20

Preferably there is or are only one or a few long reinforcing fibres that run repeatedly around the barrel.

25

As a result the resistance of the barrel to pressure from the inside is better, because the reinforcing fibres have a high tensile strength.

30

Hereby the reinforcing fibres are preferably embedded in a binder, whereby the binder is preferably polypropylene or polyethylene. Thanks to the binder a good attachment to the first layer is obtained.

5

In a further preferred embodiment the barrel is provided with a third layer that is made of plastic, whereby the third layer is outside the second layer.

10 Such a third layer is used to protect the first and second layer against impacts and other possible damage from the outside. As a result a shape can also be given to the barrel that enables a stable placement on a surface and also a stable stacking of the barrels, which would be
15 difficult or even impossible if the second, fibre-reinforced, layer is the outside layer.

The third layer also has a decorative function.

20 The third layer is preferably made of polyethylene or polypropylene by means of injection moulding.

The third layer can be attached to the second layer, but preferably the third layer is not attached to the second
25 layer and is made of two or more parts that are detachably fastened together.

This means that the third layer, in the form of a shell, is easy to affix and also easy to replace in the event of
30 damage. Such damage is to be expected, certainly in view of

the reusability of the barrels, because such barrels are moved a lot and thereby can easily be knocked or fall.

The invention further concerns the use of a barrel as described above for storing CO₂-containing drinks, in particular beer.

With the intention of better showing the characteristics of the invention, a preferred embodiment of a barrel according to the invention is described hereinafter by way of an example, without any limiting nature, with reference to the accompanying drawings, wherein:

figure 1 shows a cross-section of a barrel according to the invention;
figure 2 shows the part of the barrel of figure 1 indicated by F2 on a larger scale; and
figure 3 shows a step in the production of the barrel of figure 1.

20

The barrel 1 shown in figures 1 and 2 essentially consists of a rigid holder 2 and a connecting piece 3 affixed therein with two flexible holders 4,5.

25 The rigid holder 2 is made up of three layers, i.e. a first inner layer 6, a second middle layer 7 and a third outer layer 8.

The first layer 6 is made of high density polyethylene, HDPE, and has a thickness of approximately 3 mm. The second layer 7 is a composite layer, also with a thickness of

30

approximately 3 mm, formed by a long glass fibre 9 that is wound around the first layer 6 and which is embedded in low density polyethylene, LDPE, 10. The second layer 7 is fused onto the first layer 6, such that these two layers 6,7 are
5 attached together very firmly.

The third layer 8 is also made of HDPE and is relatively loosely affixed around the first layer 6 and second layer 7, so that there is some space 11 between the second layer
10 7 and the third layer 8. The third layer 8 consists of two parts, i.e. a base piece 12 and a top piece 13.

The base piece 12 and the top piece 13 are fastened together around the periphery by means of screws 14.

15

The rigid holder 2 has a first outlet 15 that is formed by the first layer 6, and which is provided with an external screw thread.

20 In this example, but not necessarily, the rigid holder 2 has an internal volume of 31 litres.

The connecting piece 3 is provided with two flexible holders, i.e. an inner flexible holder 4 and an outer
25 flexible holder 5. The flexible holders 4,5 are each large enough to fill the space within the rigid holder 2.

The flexible holders 4, 5 are constructed as bags with a second outlet 16 to which the connecting piece 3 is
30 fastened. The flexible holders 4, 5 are made of a

multilayer foil with a metallised layer, in order to be impermeable to CO₂ and oxygen.

The connecting piece 3 is provided with an internal screw thread that fits on the external screw thread of the rigid holder 2, and with a connection 17 for a pressure medium source, in this example a CO₂ cylinder, whereby a channel 18 is provided from the connection 17 to the space 19 between the inner flexible holder 4 and the outer flexible holder 5.

A tube 20 is fastened to the connecting piece 3 that is located in the flexible holders 4,5. A tap can be mounted on top of the connecting piece 3.

15

The use of the barrel 1 of figure 1 is simple and as follows.

The barrel 1 is assembled by sliding the tube 20 and the two flexible holders 4,5 through the first outlet 15 and screwing the connecting piece 3 onto the first outlet 15 of the rigid holder 2.

Using a special filling head the inner flexible holder 4 can now be filled, via the connecting piece 3, with such a quantity of beer that the barrel 1 is practically completely filled, in this example with 30 litres of beer.

A long shelf life of the beer is now obtained because due to the low permeability to CO₂ and oxygen of the two

30

10

flexible holders, no CO₂ can escape from the beer and no oxygen can diffuse from the outside air to the inside.

When the barrel 1 filled with beer has to be used, a CO₂
5 capsule is connected to the connection 17 provided to this end, so that CO₂ can flow into the space 19 between the inner flexible holder 4 and the outer flexible holder 5 and this space 19 can be placed under pressure. The outer flexible holder 5 is hereby pushed against the first layer
10 6 of the rigid holder 2. A tap is also affixed on the connecting piece 3.

When the tap is opened the beer flows to the outside due to the pressure applied by the tube 20.

15

When the barrel 1 is empty, the connecting piece 3 with the flexible holders 4,5 can be removed and destroyed. The combination of the connecting piece 3 and the flexible holders 4,5 is practically impossible to clean, so that
20 reuse is not possible.

The remaining rigid 2 holder is inspected for damage. If the base piece 12 is damaged, it can easily be replaced by unscrewing the screws 14, affixing a new base piece 12 and
25 tightening the screws 14 again.

If the top piece 13 is damaged it can be replaced in a similar way, whereby the first layer 6 and the second layer 7 can be slid out of the top piece 13 thanks to the space
30 11 that is between the second layer 7 and the top piece 13, and can be slid into a new top piece 13.

The rigid holder 2 can now be provided with a new connecting piece 3 with new flexible holders 4,5, and filled with beer again.

5

The rigid holder 2 can be produced as follows.

A separate holder 6, that will later form the first layer, is produced by injection moulding. The top piece 13 and the
10 base piece 12 of the third layer 8 are also separately produced by means of injection moulding.

The said separate holder 6 is wrapped with glass fibre 9, by means of a winding machine 21, and this glass fibre 9 is
15 first guided through a bath 22 of molten LDPE 10. This is shown in figure 3.

Hereby various layers of windings are placed crosswise in order to form together the second layer 7 of the rigid
20 holder 2.

Due to the fact that the LDPE 10 on the glass fibre 9 is still molten when it is wound, a very good attachment is brought about between the separate holder 6 and the wound
25 layer 7. Attention must be paid here to the positioning of the various components so that the distance between the bath 22 of molten LDPE 10 and the winding machine 22 is not so large that the LDPE 10 has already solidified when it is wound around the separate [holder].

30

12

As an alternative to molten LDPE 10, adhesive, resin and similar can be used to bring about a good attachment to the separate holder 6.

- 5 Then the wound separate holder, that is equivalent to the first layer 6 and the second layer 7, is slid in a top piece 13, after which the third layer is completed by affixing a base piece 12.
- 10 The present invention is by no means limited to the embodiment described as an example and shown in the drawings, but a barrel according to the invention can be realised in all kinds of forms and dimensions without departing from the scope of the invention.

15

AMENDED CLAIMS

received by the International Bureau on 26 January 2017 (26.01.2017)

1. - Barrel for CO₂-containing drinks, whereby the barrel comprises a rigid holder that comprises at least two layers, i.e. a first layer that is made of a polymer and a second, fibre-reinforced, layer, whereby the second layer is outside the first layer and whereby the second layer is attached to the first layer, characterised in that the barrel also comprises two flexible holders located in the rigid holder, comprising an inner flexible holder and an outer flexible holder with a space inbetween that can be placed under pressure.
- 2.- Barrel according to claim 1, characterised in that the rigid holder comprises a first outlet and that the flexible holders comprise a second outlet, whereby the second outlet is provided with a connecting piece that is connected to the first outlet and whereby the connecting piece is also provided with a tap or a connection for a tap.
3. - Barrel according to any one of the previous claims, characterised in that the first layer is essentially made of an injection-mouldable polymer, preferably polyethylene or polypropylene.
4. - Barrel according to any one of the previous claims, characterised in that the second layer is a glase-fibre reinforced layer.
- 5.-Barrel according to any one of the previous claims, characterised in that the second layer is provided with one or more reinforcing fibres are wound around the first layer.
- 6.- Barrel according to claim 6, characterised in that the reinforcing fibres are embedded in a binder, whereby the hinder is preferably polypropylene or polyethylene.
7. - Barrel according to any one of the previous claims, characterised in that it is provided with a barrier layer to

prevent the diffusion of oxygen from the outside to the inside and the diffusion of CO₂ from the inside to the outside.

8. - Barrel according to any one of the previous claims, characterised in that it has a content that is between 1 and 50 litres, and preferably between 3 and 40 litres.

9. - Barrel according to any one of the previous claims, characterised in that it is at least partially filled with beer.

10. - Use of a barrel according to any one of the claims 1 to 16 for the storage of CO₂-containing drinks, in particular beer.

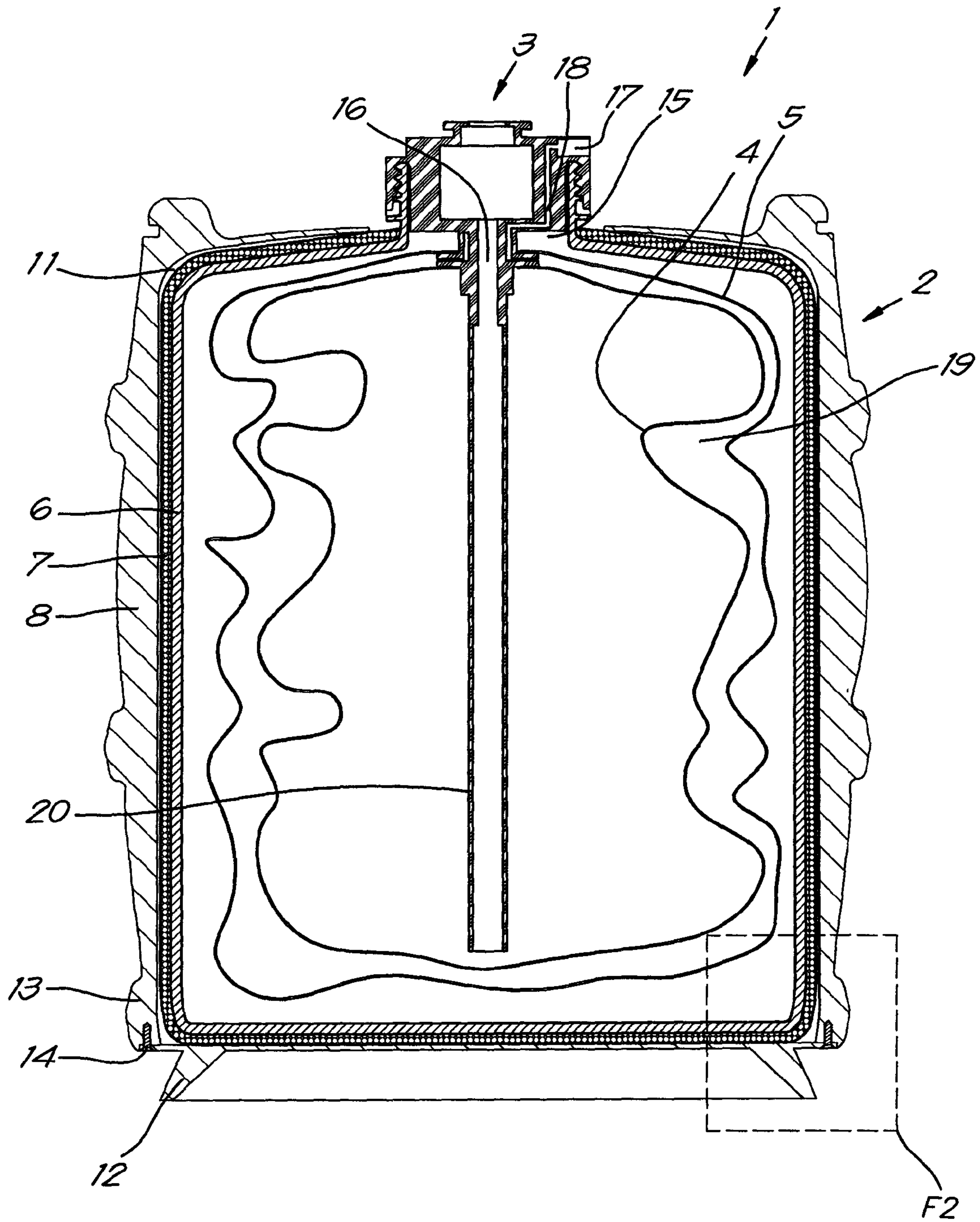


Fig. 1

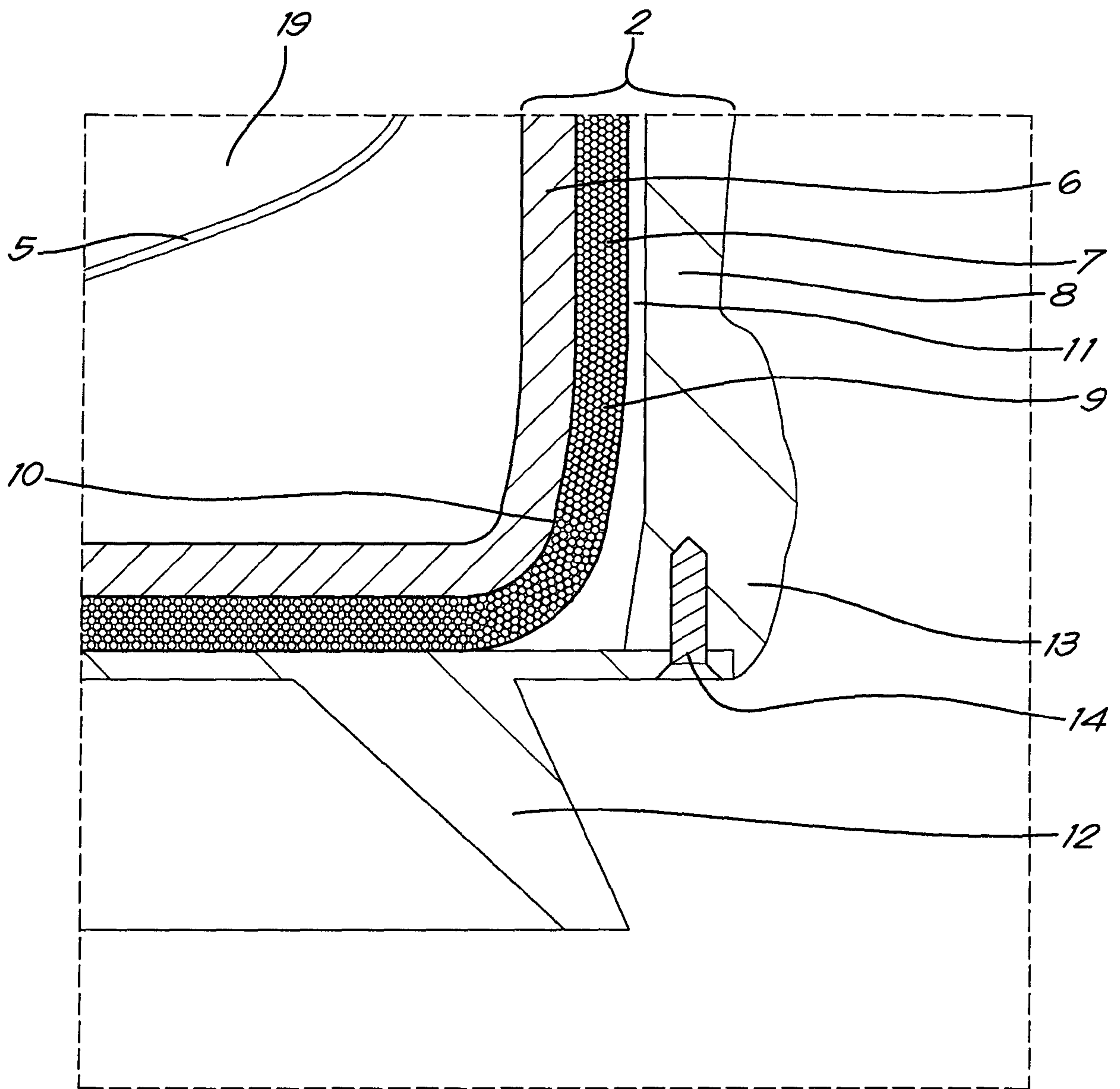


Fig. 2

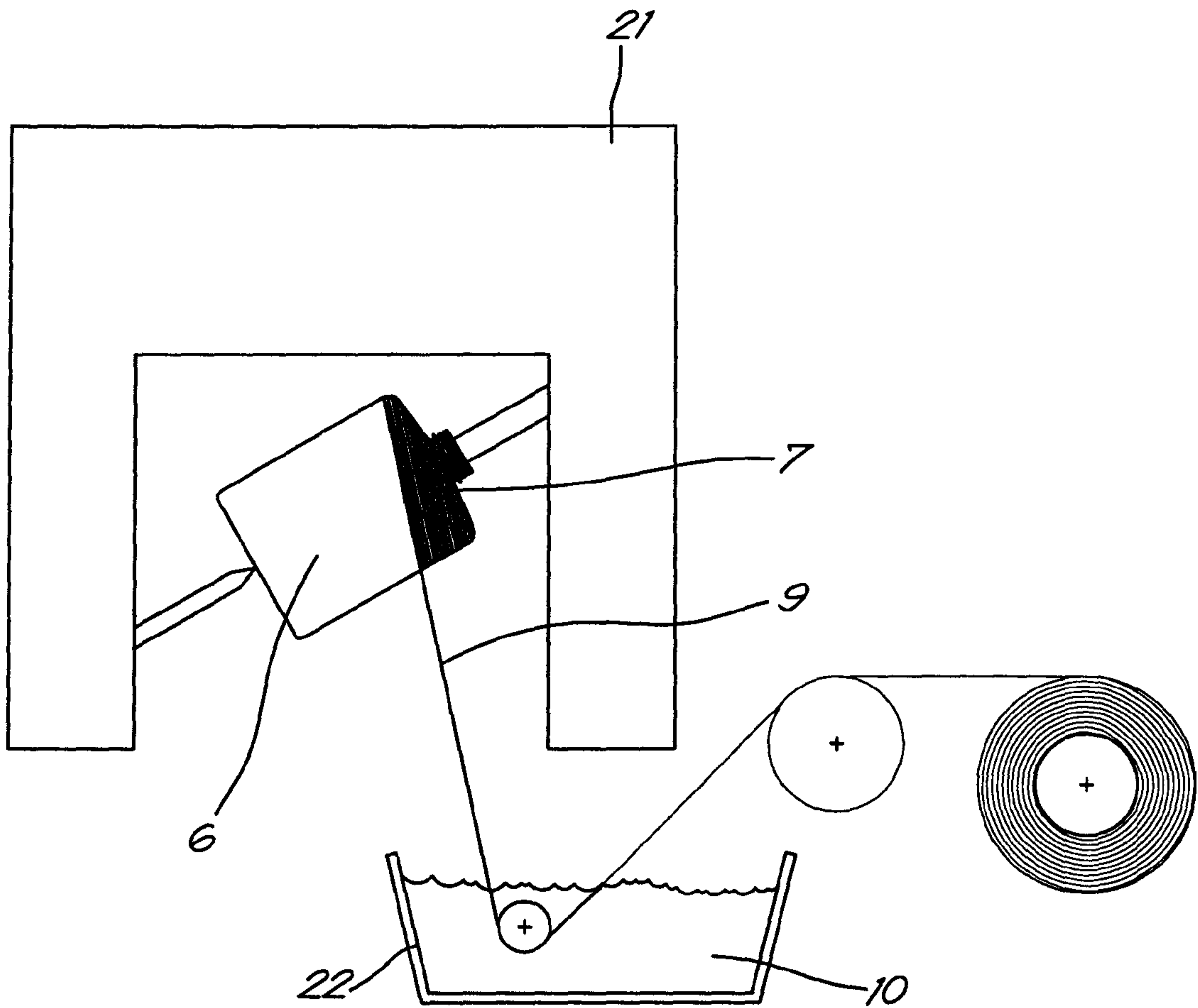


Fig. 3

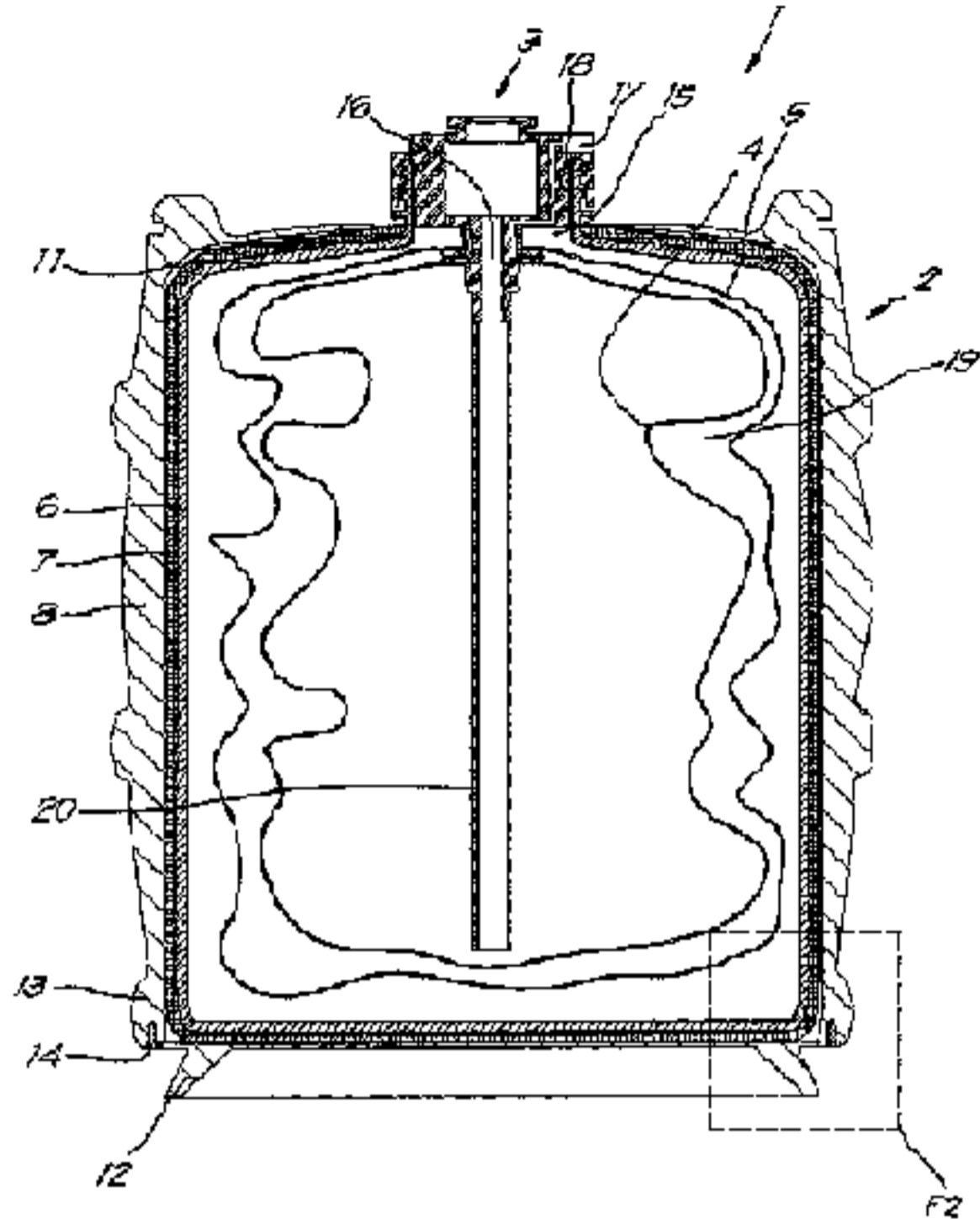


Fig. 1

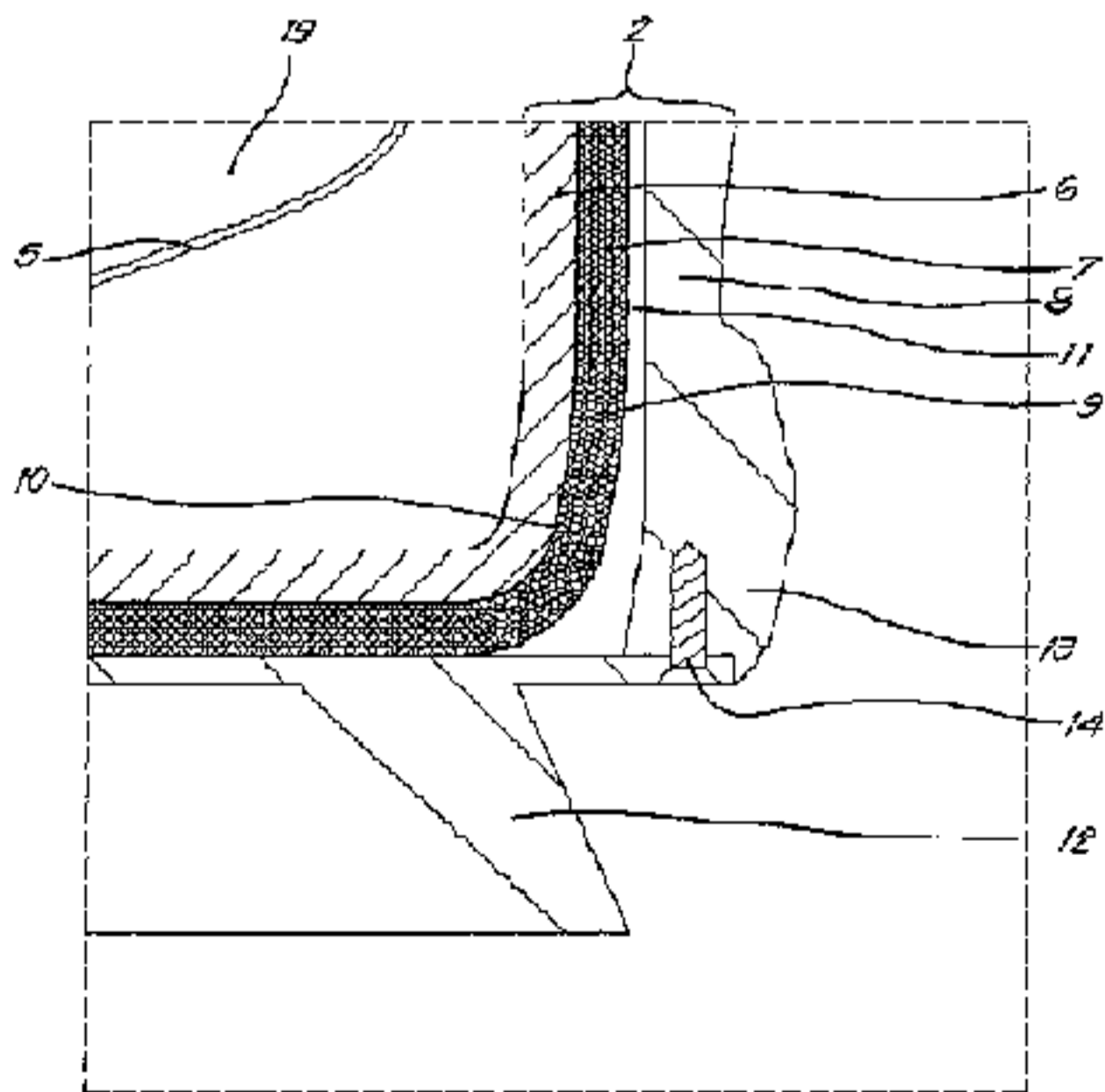


Fig. 2