

(No Model.)

2 Sheets—Sheet 1.

H. A. BARBER.  
AIR OR GAS COMPRESSOR.

No. 526,288.

Patented Sept. 18, 1894.

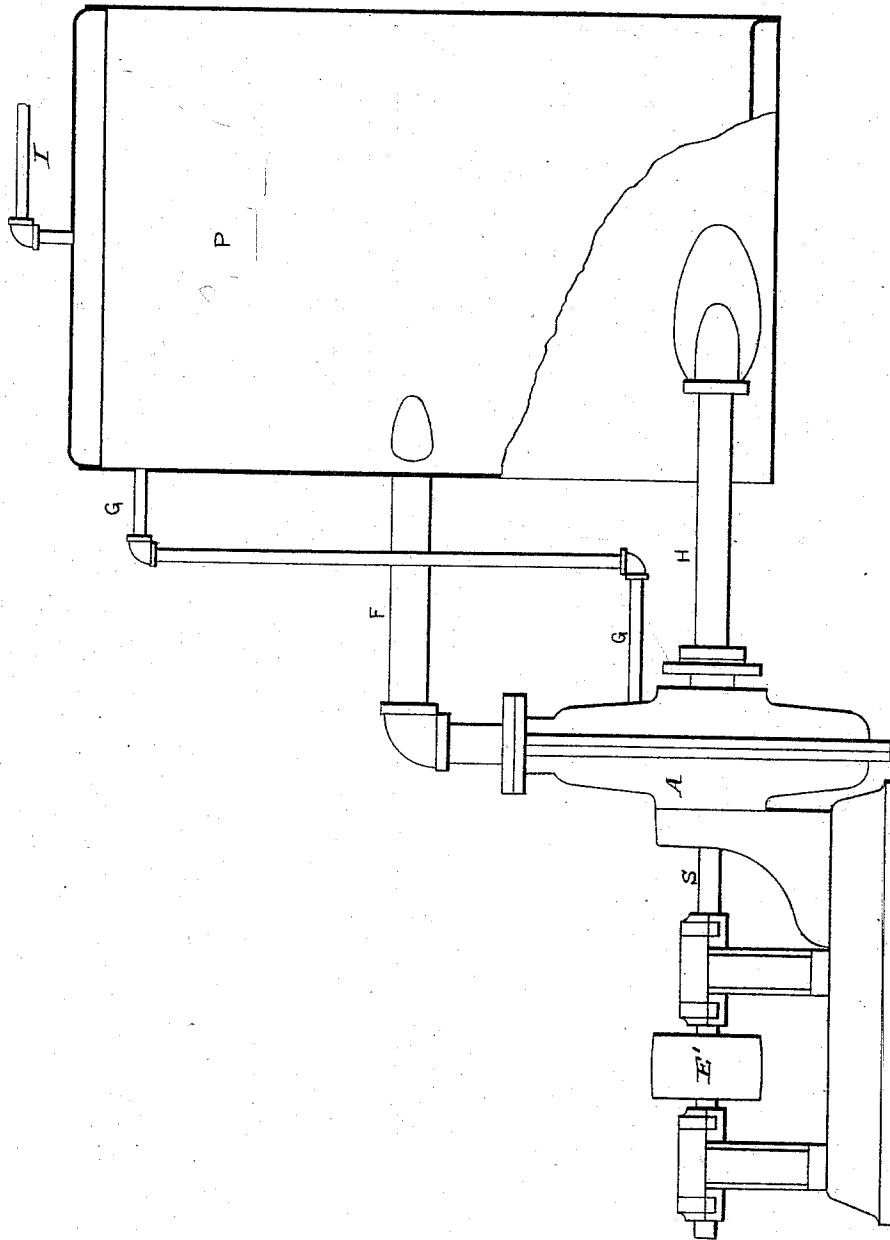

FIG. 1.

WITNESSES:

*Wm. L. Boyden*  
*Edw. S. Inwall Jr.*

INVENTOR

*Henry A. Barber*

BY

*Leuelon P. Brock*  
ATTORNEY.

(No Model.)

2 Sheets—Sheet 2.

H. A. BARBER,  
AIR OR GAS COMPRESSOR.

No. 526,288.

Patented Sept. 18, 1894.

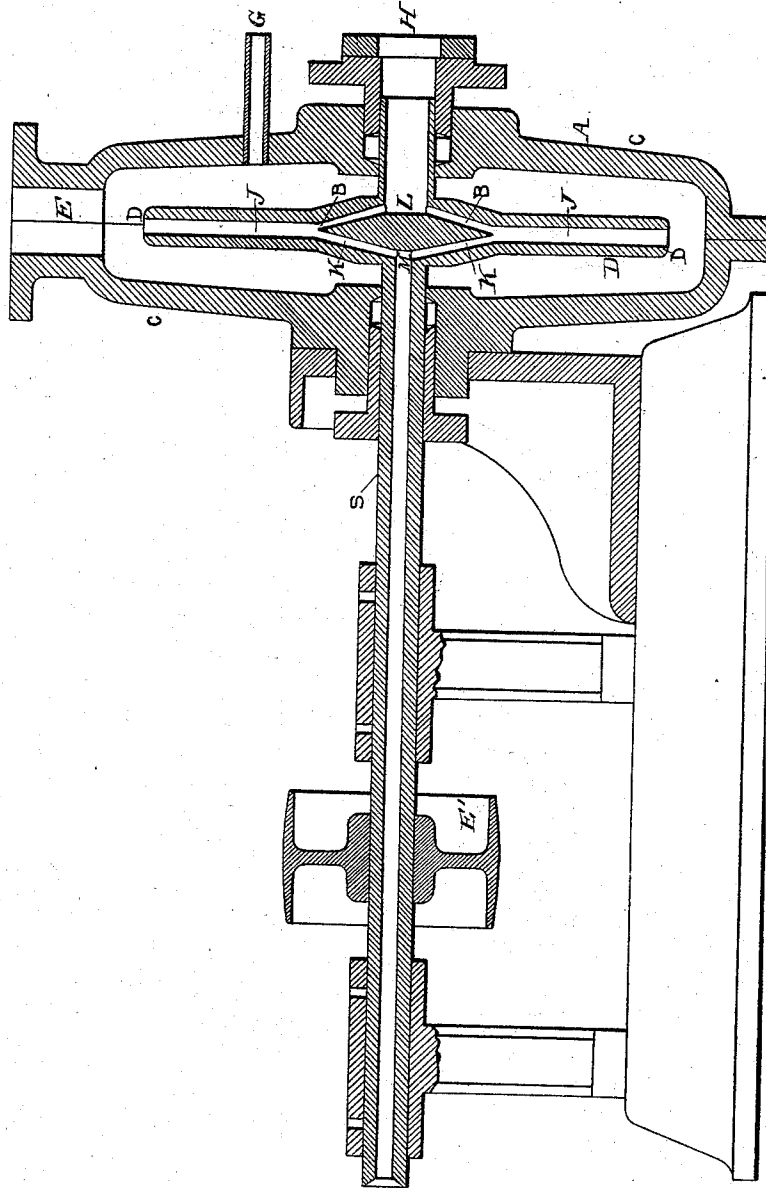

FIG. 2

WITNESSES:

*Wm L. Boydell*  
*Edw. S. Inwall, Jr.*

INVENTOR

*Henry A. Barber*  
BY  
*Leuelo R. Brock*  
ATTORNEY.

# UNITED STATES PATENT OFFICE.

HENRY A. BARBER, OF WATERTOWN, NEW YORK, ASSIGNOR OF ONE-HALF  
TO ALBERT H. LEFEBVRE, OF SAME PLACE.

## AIR OR GAS COMPRESSOR.

SPECIFICATION forming part of Letters Patent No. 526,288, dated September 18, 1894.

Application filed June 14, 1893. Serial No. 477,609. (No model.)

*To all whom it may concern:*

Be it known that I, HENRY A. BARBER, a citizen of the United States, residing at Watertown, in the county of Jefferson, State of New York, have invented certain new and useful Improvements in Air or Gas Compressors; and I do declare the following to be a full, clear, and exact description of the invention, such as will enable others skilled in the art to which it appertains to make and use the same, reference being had to the accompanying drawings, and to the letters of reference marked thereon, which form a part of this specification.

The invention relates to air or gas compressors.

The improvements consist in a new method, combination and construction of parts which will first be described in detail, and the features of novelty then set forth in the claims.

Figure 1 represents an elevation and partial section of an apparatus embodying my invention. Fig. 2 is a longitudinal vertical section of the pump.

In the drawings—A indicates the pump and P the air storage tank.

Throughout the specification where the word air is used, air, gas, or vapor or other aeriform substance is meant, and where the word water is employed, any kind of liquid is contemplated.

Reservoir P contains both air and water, the former being contained in the upper portion.

H is a pipe connecting the pump water inlet H' preferably with the bottom of reservoir P, and F, the pump discharge communicating with the reservoir preferably higher up.

G is an air pipe connecting the pump chamber with the upper end of the reservoir, and I, a pipe for tapping the compressed air.

S is the air inlet shaft of the pump, and E', a drive pulley keyed thereon for operating the pump.

C is the pump casing.

D is a centrifugal disk piston.

J is a series of preferably radial passages made in the disk, from the inner ends of which diverge focal passages B and K extending to the axis of the piston, the former communicating with the water inlet L, and the latter with the air inlet M. I prefer to choke

the water supply at the inlet L, or, in other words, the combined capacity of the passages B is less than that of the inlet pipe. The action of the centrifugal piston is thereby improved in efficiency. The air inlet M may or may not be choked.

When the air compressor is operated, the shaft S is being driven by its driving pulley, and the piston D rotated. The water fed through the pipe H to the inlet L, is caught at that point by the centrifugal action and forced out through the passages B and J into the pump casing C. Pipe F discharges the fluid back again into the reservoir.

The rapid movement and operation of the piston in pumping the liquid causes air to enter shaft S, and into passages K, where it is entrained with the water in the passages J, and both air and water discharged into the pump casing. A portion of the air in the pump is carried through the water discharge pipe F into reservoir P, and the balance through the pipe G. The air being of less specific gravity than the water, the latter is forced out against the outer walls of the casing, while the air takes possession of that portion of the chamber nearer the axis of the piston, from which it is tapped and led away by the pipe G. The water is used over and over again, constantly entraining air and storing it in the upper portion of the reservoir, to be used for any purpose desired.

I prefer to connect the pipes F and G tangentially with the reservoir in order to induce a circulation of water therein, and thereby aid in the separation of the air from the water.

Now that I have exemplified my method of compressing air or gas in an apparatus which will carry it into operation, I do not wish to confine myself to such apparatus, as I may use other devices for securing the same end in connection with my improvements.

By my invention air can be entrained with water and forced against a pressure much greater than that due to the action of centrifugal force acting alone upon air, as the latter is but slightly affected by centrifugal force owing to its being of much lighter specific gravity.

The outside of the piston is smoothly fin-

ished, and not at all in close contact with the casing. The contents of the casing are therefore but slightly effected by the piston's rotation. What slight rotary motion of the water there is in the casing aids in separating therein the air from the water, in the central portion of which the former is discharged through the air pipe G. The water seeks the outer portion of the casing.

10 In the continuous circulation of the practically solid water through the pump and separator the temperature increases according to the degree of compression of the air. The air, if desired, may be delivered at a temperature in accordance with the action of the pump.

I claim—

1. The herein described method of compressing air which consists in entraining air with a given body of water under pressure and forcing the commingled air and water continuously through a return circulating system, then separating the air from the water, and finally storing compressed air.

25 2. The improvement in the art of entraining air or gas, which consists in leading a fluid and air within an inclosed chamber to a center of centrifugal action therein, there subjecting the same to centrifugal force, then discharging the fluid from the chamber at the outer field of such action and the air from the chamber at an intermediate point and delivering both into a common reservoir, the air to be stored or held for use and the water to be supplied by suitable connection back to the center of centrifugal action.

35 3. The improvement described, which consists in constantly circulating a body of fluid, entraining air or gas at one point, subjecting

the whole to the action of centrifugal force, discharging the fluid at the outer field of the centrifugal force and discharging the air or gas from an intermediate point within the outer field into a closed reservoir.

4. The combination of a given body of water under pressure, a pump, a pump chamber, a reservoir, a pipe leading from the reservoir to the pump inlet, a discharge pipe from the pump to the reservoir, and an air or gas inlet for the pump.

5. The combination of a given body of water under pressure, a pump having a centrifugal piston, an air or gas inlet connected therewith, a reservoir and pipes leading from the pump discharge thereto, and from said reservoir to the pump inlet.

6. The combination of a pump, a pump chamber, a reservoir, a pipe connecting the pump inlet and reservoir, a pipe connecting the pump discharge and reservoir, and a pipe connecting the piston chamber at an intermediate point with the reservoir.

7. The combination of a pump, a reservoir, and pipes leading from the pump inlet and connecting tangentially with the reservoir.

8. The combination of a pump, a pump chamber, a reservoir, pipes leading from both the discharge opening and inlet of the pump and connecting tangentially with the reservoir, and a pipe connecting the pump chamber with the reservoir.

In testimony whereof I affix my signature in the presence of two witnesses.

HENRY A. BARBER.

Witnesses:

E. G. MOSHER,

GEO. V. S. CAMP.