



- (51) International Patent Classification: E21B 47/10 (2012.01)
- (21) International Application Number: PCT/US2014/012115
- (22) International Filing Date: 17 January 2014 (17.01.2014)
- (25) Filing Language: English
- (26) Publication Language: English
- (30) Priority Data: 13/747,100 22 January 2013 (22.01.2013) US
- (71) Applicant: HALLIBURTON ENERGY SERVICES, INC. [US/US]; 10200 Bellaire Boulevard, Houston, Texas 77072 (US).
- (72) Inventors: HOWELL, Matthew Todd; 2412 Mallard Drive, Duncan, Oklahoma 73533 (US). PACEY, Kendall Lee; 2008 West Club Road, Duncan, Oklahoma 73533 (US).
- (74) Agents: CONLEY ROSE, P.C. et al.; 5601 Granite Parkway, Suite 500, Plano, Texas 75024 (US).
- (81) Designated States (unless otherwise indicated, for every kind of national protection available): AE, AG, AL, AM, AO, AT, AU, AZ, BA, BB, BG, BH, BN, BR, BW, BY, BZ, CA, CH, CL, CN, CO, CR, CU, CZ, DE, DK, DM, DO, DZ, EC, EE, EG, ES, FI, GB, GD, GE, GH, GM, GT,

HN, HR, HU, ID, IL, IN, IR, IS, JP, KE, KG, KN, KP, KR, KZ, LA, LC, LK, LR, LS, LT, LU, LY, MA, MD, ME, MG, MK, MN, MW, MX, MY, MZ, NA, NG, NI, NO, NZ, OM, PA, PE, PG, PH, PL, PT, QA, RO, RS, RU, RW, SA, SC, SD, SE, SG, SK, SL, SM, ST, SV, SY, TH, TJ, TM, TN, TR, TT, TZ, UA, UG, US, UZ, VC, VN, ZA, ZM, ZW.

(84) Designated States (unless otherwise indicated, for every kind of regional protection available): ARIPO (BW, GH, GM, KE, LR, LS, MW, NA, RW, SD, SL, SZ, TZ, UG, ZM, ZW), Eurasian (AM, AZ, BY, KG, KZ, RU, TJ, TM), European (AL, AT, BE, BG, CH, CY, CZ, DE, DK, EE, ES, FI, FR, GB, GR, HR, HU, IE, IS, IT, LT, LU, LV, MC, MK, MT, NL, NO, PL, PT, RO, RS, SE, SI, SK, SM, TR), OAPI (BF, BJ, CF, CG, CI, CM, GA, GN, GQ, GW, KM, ML, MR, NE, SN, TD, TG).

Declarations under Rule 4.17:

- as to applicant's entitlement to apply for and be granted a patent (Rule 4.17(ii))
- as to the applicant's entitlement to claim the priority of the earlier application (Rule 4.17(iii))

Published:

- without international search report and to be republished upon receipt of that report (Rule 48.2(g))

(54) Title: PRESSURE TESTING VALVE AND METHOD OF USING THE SAME

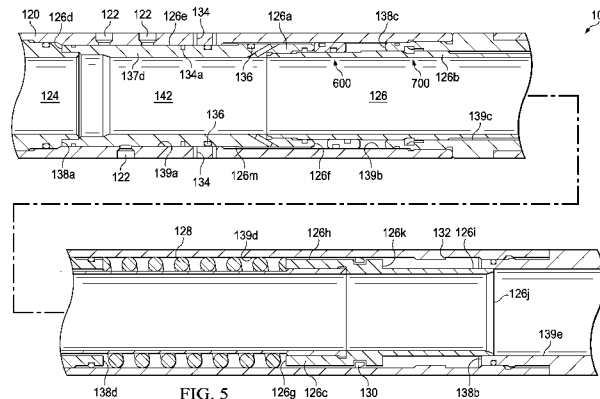

WO 2014/116525 A2

(57) Abstract: A wellbore servicing system comprising a valve comprising a housing comprising ports, and a sleeve slidably positioned within the housing and transitional from a first to a second position to a third position, when the sleeve is in the first position and the second position, the sleeves blocks fluid communication via the ports and, when in the third position the sleeve does not block such fluid communication, wherein application of a fluid pressure transitions the sleeve from the first to the second position, and a reduction in fluid pressure transitions the sleeve from the second to the third position, and a deactivatable locking assembly between the housing and the sliding sleeve and configured such that, when activated, the locking assembly inhibits movement of the sleeve toward the third position, and when deactivated, the locking assembly will not inhibit movement of the sliding sleeve toward the third position.

PRESSURE TESTING VALVE AND METHOD OF USING THE SAME

BACKGROUND

[0001] Hydrocarbon-producing wells often are stimulated by hydraulic fracturing operations, wherein a servicing fluid such as a fracturing fluid or a perforating fluid may be introduced into a portion of a subterranean formation penetrated by a wellbore at a hydraulic pressure sufficient to create or enhance at least one fracture therein. Such a subterranean formation stimulation treatment may increase hydrocarbon production from the well.

[0002] When wellbores are prepared for oil and gas production, it is common to cement a casing string within the wellbore. Often, it may be desirable to cement the casing within the wellbore in multiple, separate stages. Furthermore, stimulation equipment may be incorporated within the casing string for use in the overall production process. The casing and stimulation equipment may be run into the wellbore to a predetermined depth. Various “zones” in the subterranean formation may be isolated via the operation of one or more packers, which may also help to secure the casing string and stimulation equipment in place, and/or via cement.

[0003] Following placement of the casing string and stimulation equipment within the wellbore, it may be desirable to “pressure test” the casing string and stimulation equipment, to ensure the integrity of both, for example, to ensure that a hole or leak has not developed during placement of the casing string and stimulation equipment. Pressure-testing generally involves pumping a fluid into an axial flowbore of the casing string such that a pressure is internally applied to the casing string and the stimulation equipment and maintaining that hydraulic pressure for sufficient period of time to ensure the integrity of both, for example, to ensure that a hole or leak has not developed. To accomplish this, no fluid pathway out of the casing string can be open, for example, all ports or windows of the fracturing equipment, as well as any additional routes of fluid communication, must be closed or restricted.

[0004] Following the pressure test, it may be desirable to provide at least one route of fluid communication out of the casing string. Conventionally, the methods and/or tools employed to provide fluid pathways out of the casing string after the performance of a pressure test are configured to open upon exceeding the pressure levels achieved during pressure testing, thereby limiting the pressures that may be achieved during that pressure test. Such excessive pressure levels required to open the casing string may jeopardize the structural integrity of the casing string

and/or stimulation equipment, for example, by requiring that the casing and/or various other wellbore servicing equipment components be subjected to pressures near or in excess of the pressures for which such casing string and/or wellbore servicing component may be rated. Thus, a need exists for improved pressure testing valves and methods of using the same.

SUMMARY

[0005] Disclosed herein is a wellbore servicing system comprising a casing string, and a pressure testing valve, the pressure testing valve incorporated within the casing string and comprising a housing comprising one or more ports and an axial flowbore, and a sliding sleeve, wherein the sliding sleeve is slidably positioned within the housing and transitional from a first position to a second position, and from the second position to a third position, wherein, when the sliding sleeve is in the first position and the second position, the sliding sleeves blocks a route of fluid communication via the one or more ports and, when the sliding sleeve is in the third position the sliding sleeve does not block the route of fluid communication via the one or more ports, wherein the pressure testing valve is configured such that application of a fluid pressure of at least an upper threshold to the axial flowbore causes the sliding sleeve to transition from the first position to the second position, and wherein the pressure testing valve is configured such that a reduction of the fluid pressure to not more than a lower threshold applied to the axial flowbore causes the sliding sleeve to transition from the second position to the third position, and a deactivatable locking assembly disposed between the housing and the sliding sleeve, wherein the deactivatable locking assembly is configured such that, when activated, the deactivatable locking assembly will inhibit movement of the sliding sleeve in the direction of the third position, and when deactivated, the deactivatable locking assembly will not inhibit movement of the sliding sleeve in the direction of the third position.

[0006] Also disclosed herein is a wellbore servicing method comprising positioning casing string having a pressure testing valve incorporated therein within a wellbore penetrating the subterranean formation, wherein the pressure testing valve comprises a housing comprising one or more ports and an axial flowbore, a sliding sleeve, wherein the sliding sleeve is slidably positioned within the housing, wherein the sliding sleeve is configured to block a route of fluid communication via one or more ports when the casing string is positioned within the wellbore, and a floating piston assembly slidably disposed between the housing and the sliding sleeve, wherein the floating piston assembly is configured so as to not apply longitudinal force to the

sliding sleeve, applying a fluid pressure of at least an upper threshold to the axial flowbore, wherein, upon application of the fluid pressure of at least the upper threshold, the sliding sleeve continues to block the route of fluid communication and the floating piston assembly continues to not apply a longitudinal force to the sliding sleeve, and reducing the fluid pressure to not more than a lower threshold, wherein, upon reduction of the fluid pressure to not more than the lower threshold, the sliding sleeve allows fluid communication via one or more ports of the housing and the floating piston assembly applies a downward force to the sliding sleeve.

[0007] Further disclosed herein is a wellbore servicing tool comprising a housing comprising an axial flowbore, and a sliding sleeve, wherein the sliding sleeve is slidably, longitudinally movable within the housing; and a floating piston assembly slidably disposed between the housing and the sliding sleeve, wherein the floating piston is configured such that, when unactivated, the floating piston assembly will not apply a force to the sliding sleeve in either a first longitudinal direction or a second longitudinal direction, and when activated, the floating piston assembly will apply a force to the sliding sleeve in the first longitudinal direction.

[0008] Further disclosed herein is a wellbore servicing system comprising a casing string, and a pressure testing valve, the pressure testing valve incorporated within the casing string and comprising a housing comprising one or more ports and an axial flowbore, and a sliding sleeve, wherein the sliding sleeve is slidably positioned within the housing and transitional from a first position to a second position, and from the second position to a third position, wherein, when the sliding sleeve is in the first position and the second position, the sliding sleeves blocks a route of fluid communication via the one or more ports and, when the sliding sleeve is in the third position the sliding sleeve does not block the route of fluid communication via the one or more ports, wherein the pressure testing valve is configured such that application of a fluid pressure of at least an upper threshold to the axial flowbore causes the sliding sleeve to transition from the first position to the second position, and wherein the pressure testing valve is configured such that a reduction of the fluid pressure to not more than a lower threshold applied to the axial flowbore causes the sliding sleeve to transition from the second position to the third position, and a deactivatable locking assembly disposed between the housing and the sliding sleeve, wherein the deactivatable locking assembly is configured such that, when activated, the deactivatable locking assembly will inhibit movement of the sliding sleeve in the direction of the third position,

and when deactivated, the deactivatable locking assembly will not inhibit movement of the sliding sleeve in the direction of the third position.

[0009] Further disclosed herein is a wellbore servicing method comprising positioning casing string having a pressure testing valve incorporated therein within a wellbore penetrating the subterranean formation, wherein the pressure testing valve comprises a housing comprising one or more ports and an axial flowbore, a sliding sleeve, wherein the sliding sleeve is slidably positioned within the housing in a first position in which the sliding sleeve is configured to block a route of fluid communication via one or more ports when the casing string is positioned within the wellbore, and a deactivatable locking assembly disposed between the housing and the sliding sleeve, wherein the deactivatable locking assembly is configured so as to inhibit movement of the sliding sleeve in the direction of a third position, applying a fluid pressure of at least an upper threshold to the axial flowbore, wherein, upon application of the fluid pressure of at least the upper threshold, the sliding sleeve transitions to a second position in which the sliding sleeve continues to block the route of fluid communication, and wherein, upon movement of the sliding sleeve from the first position in the direction of the second position, the deactivatable locking assembly is configured so as to not inhibit movement of the sliding sleeve in the direction of a third position; and reducing the fluid pressure to not more than a lower threshold, wherein, upon reduction of the fluid pressure to not more than the lower threshold, the sliding sleeve transitions to a third position in which the sliding sleeve allows fluid communication via one or more ports of the housing.

[0010] Further disclosed herein is a wellbore servicing tool comprising a housing comprising an axial flowbore, and a sliding sleeve, wherein the sliding sleeve is slidably, longitudinally movable within the housing, and a deactivatable locking assembly disposed between the housing and the sliding sleeve, wherein the deactivatable locking assembly is configured such that, when activated, the deactivatable locking assembly will inhibit movement of the sliding sleeve in a first longitudinal direction and will not inhibit movement in a second longitudinal direction, wherein the first direction is generally opposite of the second direction, and when deactivated, the deactivatable locking assembly will not inhibit movement of the sliding sleeve the first direction.

BRIEF DESCRIPTION OF THE DRAWINGS

[0011] For a more complete understanding of the present disclosure and the advantages thereof, reference is now made to the following brief description, taken in connection with the accompanying drawings and detailed description:

[0012] Figure 1 is a partial cut-away view of an operating environment of a pressure testing valve depicting a wellbore penetrating a subterranean formation and a casing string having a pressure testing valve incorporated therein and positioned within the wellbore;

[0013] Figure 2 is a cut-away view of an upper portion of a pressure testing valve;

[0014] Figure 3 is a cut-away view of a lower portion of a pressure testing valve;

[0015] Figure 4A is a partial cut-away view of an embodiment of a pressure testing valve in a first configuration;

[0016] Figure 4B is a partial cut-away view of an embodiment of a pressure testing valve in a second configuration;

[0017] Figure 4C is a partial cut-away view of an embodiment of a pressure testing valve in a third configuration;

[0018] Figure 5 is a partial cut-away view of an embodiment of a pressure testing valve comprising a floating piston assembly and a deactivatable locking assembly;

[0019] Figure 6A is a partial cut-away view of an embodiment of a floating piston assembly;

[0020] Figure 6B is a partial cut-away view of an embodiment of a floating piston assembly;

[0021] Figure 7A is a partial cut-away view of an embodiment of a deactivatable locking assembly in a first configuration; and

[0022] Figure 7B is partial cut-away view of an embodiment of a deactivatable locking assembly in a second configuration.

DETAILED DESCRIPTION OF THE EMBODIMENTS

[0023] In the drawings and description that follow, like parts are typically marked throughout the specification and drawings with the same reference numerals, respectively. In addition, similar reference numerals may refer to similar components in different embodiments disclosed herein. The drawing figures are not necessarily to scale. Certain features of the invention may be shown exaggerated in scale or in somewhat schematic form and some details of

conventional elements may not be shown in the interest of clarity and conciseness. The present disclosure is susceptible to embodiments of different forms. Specific embodiments are described in detail and are shown in the drawings, with the understanding that the present disclosure is not intended to limit the invention to the embodiments illustrated and described herein. It is to be fully recognized that the different teachings of the embodiments discussed herein may be employed separately or in any suitable combination to produce desired results.

[0024] Unless otherwise specified, use of the terms “connect,” “engage,” “couple,” “attach,” or any other like term describing an interaction between elements is not meant to limit the interaction to direct interaction between the elements and may also include indirect interaction between the elements described.

[0025] Unless otherwise specified, use of the terms “up,” “upper,” “upward,” “up-hole,” “upstream,” or other like terms shall be construed as generally from the formation toward the surface or toward the surface of a body of water; likewise, use of “down,” “lower,” “downward,” “down-hole,” “downstream,” or other like terms shall be construed as generally into the formation away from the surface or away from the surface of a body of water, regardless of the wellbore orientation. Use of any one or more of the foregoing terms shall not be construed as denoting positions along a perfectly vertical axis.

[0026] Unless otherwise specified, use of the term “subterranean formation” shall be construed as encompassing both areas below exposed earth and areas below earth covered by water such as ocean or fresh water.

[0027] Disclosed herein are embodiments of a pressure testing valve (PTV) and method of using the same. Particularly, disclosed herein are one or more embodiments of a PTV incorporated within a tubular, for example a casing string or liner, comprising one or more wellbore servicing tools positioned within a wellbore penetrating subterranean formation.

[0028] Where a casing string has been placed within a wellbore and, for example, prior to the commencement of stimulation (e.g., fracturing and/or perforating) operations, it may be desirable to pressure test the casing string or liner and thereby verify its integrity and functionality. In the embodiments disclosed herein, a PTV enables the casing string to be pressure tested and subsequently allow a route of fluid communication from a flowbore of the casing string to the wellbore without the use of excessive pressure threshold levels.

[0029] Referring to Figure 1, an embodiment of an operating environment in which such a PTV may be employed is illustrated. It is noted that although some of the figures may exemplify horizontal or vertical wellbores, the principles of the methods, apparatuses, and systems disclosed herein may be similarly applicable to horizontal wellbore configurations, conventional vertical wellbore configurations, and combinations thereof. Therefore, the horizontal or vertical nature of any figure is not to be construed as limiting the wellbore to any particular configuration.

[0030] Referring to Figure 1, the operating environment comprises a drilling or servicing rig 106 that is positioned on the earth's surface 104 and extends over and around a wellbore 114 that penetrates a subterranean formation 102 for the purpose of recovering hydrocarbons. The wellbore 114 may be drilled into the subterranean formation 102 by any suitable drilling technique. In an embodiment, the drilling or servicing rig 106 comprises a derrick 108 with a rig floor 110 through which a casing string 150 generally defining an axial flowbore 115 may be positioned within the wellbore 114. The drilling or servicing rig 106 may be conventional and may comprise a motor driven winch and other associated equipment for lowering the casing string 150 into the wellbore 114 and, for example, so as to position the PTV 100 and/or other wellbore servicing equipment at the desired depth.

[0031] In an embodiment the wellbore 114 may extend substantially vertically away from the earth's surface 104 over a vertical wellbore portion, or may deviate at any angle from the earth's surface 104 over a deviated or horizontal wellbore portion. In alternative operating environments, portions or substantially all of the wellbore 114 may be vertical, deviated, horizontal, and/or curved.

[0032] In an embodiment, a portion of the casing string 150 may be secured into position against the formation 102 in a conventional manner using cement 116. In alternative embodiment, the wellbore 114 may be partially cased and cemented thereby resulting in a portion of the wellbore 114 being uncemented. In an embodiment, incorporated within the casing string 150 is a PTV 100 or some part thereof. The PTV 100 may be delivered to a predetermined depth within the wellbore. In an alternative embodiment, the PTV 100 or some part thereof may be comprised along and/or integral with a liner.

[0033] It is noted that although the PTV is disclosed as being incorporated within a casing string in one or more embodiments, the specification should not be construed as so-limiting. A

wellbore servicing tool may similarly be incorporated within other suitable tubulars such as a work string, liner, production string, a length of tubing, or the like.

[0034] Referring to Figure 1, the casing string 150 and/or PTV 100 may additionally or alternatively be secured within the wellbore 114 using one or more packers 170. The packer 170 may generally comprise a device or apparatus which is configurable to seal or isolate two or more depths in a wellbore from each other by providing a barrier concentrically about a casing string and therebetween. Non-limiting examples of a packer suitably employed as packer 170 include a mechanical packer or a swellable packer (for example, SwellPackers™, commercially available from Halliburton Energy Services).

[0035] While the operating environment depicted in Figure 1 refers to a stationary drilling or servicing rig 106 for lowering and setting the casing string 150 within a land-based wellbore 114, one of ordinary skill in the art will readily appreciate that mobile workover rigs, wellbore servicing units (e.g., coiled tubing units), and the like may be used to lower the casing string 150 into the wellbore 114. It should be understood that a PTV may be employed within other operational environments, such as within an offshore wellbore operational environment.

[0036] In an embodiment, the PTV 100 is selectively configurable to either allow or disallow a route of fluid communication from a flowbore 124 thereof and/or the casing flowbore 115 to the formation 102 and/or into the wellbore 114. Referring to Figures 4A-4C, in an embodiment, the PTV 100 may generally comprise of a housing 120, a sliding sleeve 126, and one or more ports 122. In an embodiment, the PTV 100 may be configured to be transitional from a first configuration to a second configuration and from the second configuration to a third configuration.

[0037] In an embodiment as depicted in Figure 4A, the PTV 100 is illustrated in the first configuration. In the first configuration, the PTV 100 is configured to disallow fluid communication via the one or more ports 122 of the PTV 100. Additionally, in an embodiment, when the PTV 100 is in the first configuration, the sliding sleeve 126 is located (e.g., immobilized) in a first position within the PTV 100, as will be disclosed herein.

[0038] In an embodiment as depicted in Figure 4B, the PTV 100 is illustrated in the second configuration. In the second configuration, the PTV 100 is configured to disallow fluid communication via the one or more ports 122 of the PTV 100. In an embodiment as will be disclosed herein, the PTV 100 may be configured to transition from the first configuration to the

second configuration upon the application of a pressure to the PTV 100 of at least a first or upper pressure threshold. Additionally, in an embodiment when the PTV 100 is in the second configuration, the sliding sleeve 126 is in a second position and is no longer immobilized within the PTV 100, as will be disclosed herein.

[0039] In an embodiment as depicted in Figure 4C, the PTV 100 is illustrated in the third configuration. In the third configuration, the PTV 100 is configured to allow fluid communication via the one or more ports 122 of the PTV 100. In an embodiment as will be disclosed herein, the PTV may be configured to transition from the second configuration the third configuration upon allowing the pressure applied to the PTV 100 to subside to not more than a second or lower pressure threshold. Additionally, in an embodiment when the PTV is in the third configuration, the sliding sleeve 126 is located (e.g., locked) into a third position within the PTV 100.

[0040] Figure 2 and Figure 3, together, illustrate an embodiment of the PTV 100. In an embodiment the PTV 100 comprises a housing 120. In the embodiment of Figure 2 and Figure 3, the housing 120 of the PTV 100 is a generally cylindrical or tubular-like structure. The housing 120 may comprise a unitary structure; alternatively, the housing 120 may be made up of two or more operably connected components (e.g., an upper component, and a lower component). Alternatively, a housing of a PTV 100 may comprise any suitable structure; such suitable structures will be appreciated by those of skill in the art with the aid of this disclosure.

[0041] In an embodiment the PTV 100 may be configured for incorporation into the casing string 150, for example, as illustrated by the embodiment of Figure 1, or alternatively, into any suitable string (e.g., a liner or other tubular). In such an embodiment, the housing 120 may comprise a suitable connection to the casing string 150 (e.g., to a casing string member, such as a casing joint). For example, the housing may comprise internally or externally threaded surfaces. Additional or alternative, suitable connections to a casing string will be known to those of skill in the art.

[0042] In the embodiment of Figure 2 and Figure 3, the housing 120 generally defines an axial flowbore 124. Referring to Figure 1, the PTV 100 is incorporated within the casing string 150 such that the axial flowbore 124 of the PTV 100 is in fluid communication with the axial flowbore 115 of the casing string 150. For example, a fluid may be communicated between the axial flowbore 115 of the casing string 150 and the axial flowbore 124 of the PTV 100.

[0043] In the embodiment of Figure 2, the housing 120 comprises one or more ports 122. In this embodiment, the ports 122 extend radially outward from and/or inward towards the axial flowbore 124. As such, these ports 122 may provide a route of fluid communication from the axial flowbore 124 to an exterior of the housing 120 when the PTV 100 is so-configured. For example, the PTV 100 may be configured such that the ports 122 provide a route of fluid communication between the axial flowbore 124 and the wellbore 114 and/or subterranean formation 102 when the ports 122 are unblocked (e.g., by the sliding sleeve 126, as will be disclosed herein). Alternatively, the PTV 100 may be configured such that no fluid will be communicated via the ports 122 between the axial flowbore 124 and the wellbore 114 and/or the subterranean formation 102 when the ports 122 are blocked (e.g., by the sliding sleeve 126, as will be disclosed herein).

[0044] In the embodiment of Figure 2 and Figure 3, the housing 120 comprises a recess 138. In the embodiment of Figure 2 and Figure 3, the recess 138 is generally defined by a first bore surface 139a, a second bore surface 139b, a third bore surface 139c, and a fourth bore surface 139d. In this embodiment, the first bore surface 139a generally comprises a cylindrical surface spanning between an upper shoulder 138a and a first medial shoulder 138e, the second bore surface 139b generally comprises a cylindrical surface spanning between the first medial shoulder 138e and a second medial shoulder 138c, the third bore surface 139c generally comprises a cylindrical surface spanning between the second medial shoulder 138c and a third medial shoulder 138d, and the fourth bore surface 139d generally comprises a cylindrical surface spanning between the third medial shoulder 138d and a lower shoulder 138b.

[0045] In an embodiment, the first bore surface 139a may be characterized as having a diameter less than the diameter of the second bore surface 139b. Also, in an embodiment the third bore surface 139c may be characterized as having a diameter less than either the diameter of the first bore surface 139a or the diameter of the second bore surface 139b. Also, in an embodiment, the fourth bore surface 139d may be characterized as having a diameter greater than the diameter of the third bore surface 139c.

[0046] Referring to Figure 2 and Figure 3, the sliding sleeve 126 generally comprises a cylindrical or tubular structure comprising an axial flowbore extending there-through. In the embodiment of Figure 2 and Figure 3, the sliding sleeve 126 generally comprises a first sleeve segment 126a, a second sleeve segment 126b, and a third sleeve segment 126c. In such an embodiment, the first sleeve segment 126a, the second sleeve segment 126b, and the third sleeve

segment 126c are coupled together by any suitable methods as would be known by those of skill in the art (e.g., by a threaded connection). Alternatively, the sliding sleeve 126 may comprise a unitary structure (e.g., a single solid piece).

[0047] In an embodiment, the sliding sleeve may comprise one or more of shoulders or the like, generally defining one or more outer cylindrical surfaces of various diameters. Referring to Figure 2 and Figure 3, the sliding sleeve 126 comprises an upper surface 126d, a first medial shoulder 126p, a first outer cylindrical bore face 126e extending between the upper surface 126d and the first medial shoulder 126p, a second medial shoulder 126f, and a second outer cylindrical bore surface 126m. In an embodiment, the first outer cylindrical bore surface 126e may be characterized as having a diameter less than the diameter of the second outer cylindrical bore surface 126m. Further, the sliding sleeve 126 may comprise a third medial shoulder 126g and a third outer cylindrical bore surface 126q extending between the a second medial shoulder 126f and the third medial shoulder 126g. In an embodiment, the third outer cylindrical bore surface may be characterized as having a diameter less than the diameter of either of the first or the second outer bore surfaces, 126e and 126m. Further still, the sliding sleeve 126 may comprise a fourth medial shoulder 126k and a fourth outer cylindrical bore surface 126h extending between the third medial shoulder 126g and the fourth medial shoulder 126k. In an embodiment, the fourth outer cylindrical surface 126h may be characterized as having a diameter greater than the diameter of the third outer cylindrical surface 126q. Still further, the sliding sleeve 126 may comprise a lower surface 126j and a fifth outer cylindrical surface 126i extending between the fourth medial shoulder 126k and the lower surface 126j. In an embodiment, the fifth outer cylindrical surface 126i may be characterized as having a diameter less than the diameter of the fourth outer cylindrical surface 126h.

[0048] In an embodiment, the sliding sleeve 126 may be slidably and concentrically positioned within the housing. For example, in the embodiment of Figures 2 and 3, at least a portion of the first cylindrical bore face 126e of the sliding sleeve 126 may be slidably fitted against at least a portion of the first bore surface 139a of the recess 138. Further, at least a portion of the second outer cylindrical bore face 126m of the sliding sleeve 126 may be slidably fitted against at least a portion of the second bore surface 139b of the recess 138. Further still, at least a portion of the third outer cylindrical bore face 126q of the sliding sleeve 126 may be slidably fitted against at least a portion of the third bore surface 139c of the recess 138. Further still, at least a

portion of the fourth outer bore face 126h of the sliding sleeve 126 may be slidably fitted against at least a portion of the fourth bore surface 139d of the sliding sleeve 138. Further still, at least a portion of the fifth outer cylindrical bore surface 126i may be slidably fitted against at least a portion of a fifth bore surface 139e defining the axial flowbore 124.

[0049] In an embodiment, one or more of the interfaces between the sliding sleeve 126 and the recess 138 may be fluid-tight and/or substantially fluid-tight. For example, in an embodiment, the recess 138 and/or the sliding sleeve 126 may comprise one or more suitable seals at such an interface, for example, for the purpose of prohibiting or restricting fluid movement via such an interface. Suitable seals include but are not limited to a T-seal, an O-ring, a gasket, or combinations thereof. In the embodiment of Figures 2 and 3, the PTV 100 comprises a fluid seal 136a (e.g., one or more O-rings or the like) at the interface between the first cylindrical bore face 126e of the sliding sleeve 126 and the first bore surface 139a of the recess 138 and a fluid seal 136b at and/or proximate to the interface between the second outer cylindrical bore face 126m of the sliding sleeve 126 and the second bore surface 139b of the recess 138.

[0050] In an embodiment, the sliding sleeve 126 may be movable, with respect to the housing 120, from a first position to a second position and from the second to a third position with respect to the housing 120.

[0051] In an embodiment, the sliding sleeve 126 may be positioned so as to allow or disallow fluid communication via the one or more ports 122 between the axial flowbore 124 of the housing 120 and the exterior of the housing 120, dependent upon the position of the sliding sleeve 126 relative to the housing 120. Referring to Figure 4A, the sliding sleeve 126 is illustrated in the first position. In the first position, the sliding sleeve 126 blocks the ports 122 of the housing 120 and, thereby, restricts fluid communication via the ports 122. As noted above, when the sliding sleeve 126 is in the first position, the PTV 100 may be in the first configuration. Referring to Figure 4B, the sliding sleeve 126 is illustrated in the second position. In the second position, the sliding sleeve 126 blocks the ports 122 of the housing 120 and, thereby, restricts fluid communication via the ports 122. Alternatively, referring to Figure 4C, the sliding sleeve 126 is illustrated in the third position. In the third position, the sliding sleeve 126 does not block or obstruct the ports 122 of the housing 120 and, thereby allows fluid communication via the ports 122.

[0052] In an embodiment, the sliding sleeve 126 may be configured to be selectively transitioned from the first position to the second position and/or from the second position to the third position.

[0053] For example, in an embodiment the sliding sleeve 126 may be configured to transition from the first position to the second position upon the application of a hydraulic pressure of at least a first threshold to the axial flowbore 124. In such an embodiment, the sliding sleeve 126 may comprise a differential in the surface area of the upward-facing surfaces which are fluidically exposed to the axial flowbore 124 and the surface area of the downward-facing surfaces which are fluidically exposed to the axial flowbore 124. For example, in the embodiment of Figures 2 and 3, the surface area of the surfaces of the sliding sleeve 126 which will apply a force (e.g., a hydraulic force) in the direction toward the second position (e.g., an upward force) may be greater than surface area of the surfaces of the sliding sleeve 126 which will apply a force (e.g., a hydraulic force) in the direction away from the second position. For example, in the embodiment of Figures 2 and 3 and not intending to be bound by theory, because the interface between the first cylindrical bore face 126e of the sliding sleeve 126 and the first bore surface 139a of the recess 138 and the interface between the second outer cylindrical bore face 126m of the sliding sleeve 126 and the second bore surface 139b of the recess 138, as disclosed above, are fluidically sealed (e.g., by fluid seals 136a and 136b), there is a resulting chamber 142 which is unexposed to hydraulic fluid pressures applied to the axial flowbore, thereby resulting in such a differential in the force applied to the sliding sleeve in the direction toward the second position (e.g., an upward force) and the force applied to the sliding sleeve in the direction away from the second position (e.g., a downward force). For example, the first medial shoulder 126p of the sliding sleeve 126 (e.g., which is within the chamber 142) may be unexposed to the axial flowbore 124 while all other faces capable of applying a force are exposed. In an additional or alternative embodiment, a PTV like PTV 100 may further comprise one or more additional chambers (e.g., similar to chamber 142) providing such a differential in the force applied to the sliding sleeve in the direction toward the second position (e.g., an upward force) and the force applied to the sliding sleeve in the direction away from the second position (e.g., a downward force).

[0054] Also, in an embodiment the sliding sleeve 126 may be configured to be transitioned from the second position to the third position via the operation of a biasing member. For example, in the embodiment of Figures 2 and 3, the PTV 100 comprises a biasing member 128 (e.g., a

biasing spring) configured to apply a biasing force to the sliding sleeve 126 in the direction of the third position. Examples of a suitable biasing member include, but are not limited to, a spring, a pneumatic device, a compressed fluid device, or combinations thereof.

[0055] Additionally or alternatively, in an embodiment, the sliding sleeve 126 may be configured to be transitioned from the second position to the third position via the operation of a floating piston assembly (FPA). Referring to Figure 5, an embodiment of a PTV 101 (e.g., being otherwise similar to PTV 100) comprising a FPA 600 is illustrated. In an embodiment, the FPA 600 may be generally configured such that, when unactivated (e.g., prior to activation, as will be disclosed herein), the FPA 600 will not apply a force (alternatively, will apply only an insubstantial force) to the sliding sleeve 126 in either the direction of the second position (e.g., an upward force) or in the direction of the third position (e.g., a downward force). Also, the FPA 600 may be generally configured such that, when activated (e.g., following activation, as will be disclosed herein), the FPA 600 will apply a force to the sliding sleeve 126 in the direction of the third position (e.g., a downward force).

[0056] Referring to Figures 6A and 6B, the FPA 600 is illustrated in the activated configuration. In the embodiment of Figures 5, 6A, and 6B, the FPA 600 generally comprises a floating piston 610. In an embodiment, the floating piston 610 generally comprises a cylindrical, tubular, or collar-like structure. For example, in the embodiment of Figures 5, 6A, and 6B, the floating piston 610 generally comprises an upper orthogonal surface 612, a lower orthogonal surface 614, an inner cylindrical surface 616, and an outer cylindrical surface 618.

[0057] In an embodiment, the floating piston 610 may be slidably disposed between the sliding sleeve 126 and the housing 120. For example, in the embodiment of Figures 6A and 6B, the floating piston 610 is disposed between the sliding sleeve 126 and the housing 120 such that the inner cylindrical surface 616 of the floating piston 610 is slidably disposed against a sixth outer cylindrical bore surface 126r (as will be disclosed herein) and the outer cylindrical surface 618 of the floating piston 610 is slidably disposed against the second bore surface 139b of the housing 120.

[0058] Additionally, in an embodiment the interface between the housing 120 and the floating piston 610 and/or the interface between the sliding sleeve 126 and the floating piston 610 may be fluid-tight and/or substantially fluid-tight. For example, in an embodiment the floating piston (alternatively, the housing 120 and/or sliding sleeve 126) may comprise one of more

suitable seals at such interfaces. Suitable seals include but are not limited to a T-seal, an O-ring, a gasket, or combinations thereof. For example, in the embodiment of Figures 6A and 6B, the floating piston 610 comprises a suitable seal 615a at the interface between the inner cylindrical surface 616 of the floating piston 610 and the sixth outer cylindrical bore surface 126r and another suitable seal 615b at the interface between the outer cylindrical surface 618 of the floating piston 610 and the second bore surface 139b of the housing 120.

[0059] Also, in the embodiment where the PTV 101 comprises an FPA (such as FPA 600), the sliding sleeve 126 may be configured so as to engage the floating piston 610, for example, so as to impede downward movement of the floating piston 610 with respect to the sliding sleeve 126, as will be disclosed herein. For example, in the embodiment of Figures 6A and 6B the sliding sleeve 126 comprises an upwardly-facing shoulder 126s, for example, thereby differentiating the third outer cylindrical surface 126q and the sixth outer cylindrical surface 126r. In additional or alternative embodiments, the sliding sleeve 126 may comprise one or more lugs, pins, teeth, ratchets, or the like, similarly configured to engage the floating piston 610 and restrict movement thereof.

[0060] In addition, in the embodiment where the PTV 101 comprises an FPA (such as FPA 600), the sliding sleeve 126 may be configured to control fluidic access to one or more surfaces of the floating piston 610. For example, in the embodiment of the Figures 6A and 6B, the sliding sleeve 126 further comprises a check-valve 620 (e.g., a uni-directional valve or one-way valve) generally configured to control fluidic access to the upper orthogonal surface 612 of the floating piston 610. In an embodiment, the check-valve 620 may comprise any suitable type and/or configuration of a check-valve, for example, swing check valve, a tilting disc check valve, a ball check valve, or the like. Suitable examples of the check-valve 620 are commercially available as the Lee Chek line of check valves from The Lee Company of Westbrook, CT. In an embodiment, for example, in the embodiment of Figures 6A and 6B, the check-valve 620 may be generally configured to allow fluid to be communicated from the axial flowbore 124 through the sliding sleeve 126 to the upper orthogonal surface 612 of the floating piston 610 and to not allow fluid to be communicated from the area proximate to the upper orthogonal surface 612 to the axial flowbore 124.

[0061] In an embodiment, the FPA 600 may be configured to be activated (e.g., so as to apply a downward force to the sliding sleeve 126) upon the pressurization and depressurization

(e.g., a pressurization, followed by a depressurization) of the axial flowbore 124. For example, in the embodiment of Figures 6A and 6B, upon the application of pressure (e.g., a pressure of at least the upper threshold, as disclosed herein), fluid pressure may be applied to the upper orthogonal surface 612 and the lower orthogonal surface 614 of the floating piston 610. Particularly, upon pressurization of the axial flowbore 124, the pressure applied to the upper orthogonal surface 612 of the floating piston 610 may reach about the upper threshold (e.g., fluid and/or pressure may be communicated to the upper orthogonal surface 612 via the check valve 620). Also, upon pressurization of the axial flowbore 124, the pressure applied to the lower orthogonal surface 614 of the floating piston 610 may also reach the upper threshold (e.g., fluid and/or pressure may be communicated to the lower orthogonal surface 614 via the interface between the third outer cylindrical surface 126q and the third bore surface 139c, which may not be fluid-tight). For example, upon pressurization, the pressure applied to the upper orthogonal surface 612 and the lower orthogonal surface 614 may be substantially equal.

[0062] Following pressurization of the axial flowbore 124, subsequently allowing the pressure applied to the axial flowbore 124 to dissipate may result in a differential in the pressure (e.g., and therefore, the force) applied to the upper orthogonal surface 612 and the lower orthogonal surface 614 of the floating piston 610. Particularly, upon depressurization of the axial flowbore 124, the pressure applied to the upper orthogonal surface 612 of the floating piston 610 may remain at about the upper threshold (e.g., the fluid and/or pressure applied to the upper orthogonal surface 612 may be retained by the check valve 620). Also, upon depressurization of the axial flowbore 124, the pressure applied to the lower orthogonal surface 614 of the floating piston 610 may decrease (e.g., the fluid and/or pressure applied to the lower orthogonal surface 614 may decrease to about the same pressure as the axial flowbore 124, for example, via the interface between the third outer cylindrical surface 126q and the third bore surface 139c, which may not be fluid-tight). In such an embodiment, a differential in the pressure applied to the upper orthogonal surface 612 and the lower orthogonal surface 614 of the floating piston 610 may result upon the depressurization of the axial flowbore 124 and, therefore, result in a generally downward force applied to the floating piston 610 (and, thereby, to the sliding sleeve 126, via the upwardly-facing shoulder 126s).

[0063] In an embodiment, the sliding sleeve 126 may be retained in the first position, the second position, the third position, or combinations thereof by a suitable retaining mechanism.

[0064] For example, in the embodiment of Figure 4A, the sliding sleeve 126 may be held in the first position by one or more shear pins 134. Such shear pins 134 may extend between the housing 120 and the sliding sleeve 126. The shear pin 134 may be inserted or positioned within a suitable borehole in the housing 120 and the borehole 134a in the sliding sleeve 126. As will be appreciated by one of skill in the art, the shear pin 134 may be sized to shear or break upon the application of a desired magnitude of force (e.g., force resulting from the application of a hydraulic fluid pressure, such as a pressure test) to the sliding sleeve 126, as will be disclosed herein. In an alternative embodiment, the sliding sleeve 126 may be held in the first position by any suitable frangible member, such as a shear ring or the like.

[0065] Additionally or alternatively, in an embodiment, the sliding sleeve 126 may be retained from moving from the first position in the direction of the third position by a deactivatable locking assembly (DLA). For example, in the embodiment of Figure 5, the PTV 101 comprises a DLA 700. In an embodiment, the DLA 700 is generally configured such that, when activated, the DLA 700 does not allow the sliding sleeve 126 to move from the first position in the direction of the third position but does allow the sliding sleeve 126 to move from the first position in the direction of the second position. Also, the DLA 700 may be generally configured such that, when deactivated, the DLA 700 allows the sliding sleeve 126 to move from the first and/or second position in the direction of the third position.

[0066] Referring to Figures 7A and 7B, an embodiment of the DLA 700 is illustrated in the activated and deactivated configurations, respectively. In the embodiment of Figures 5, 7A, and 7B, the DLA 700 generally comprises a locking member 710, an outer profile 720 (e.g., disposed on an outer, cylindrical surface of the sliding sleeve 126), and an inner profile 730 (e.g., disposed on an inner, cylindrical surface of the housing 120).

[0067] In an embodiment, the locking member 710 comprises a ring, for example, a snapping, a biased C-ring, or the like. For example, in the embodiment disclosed herein with respect to Figures 5, 7A, and 7B, the locking member 710 comprises an outwardly-biased ring. For example, such an outwardly-biased ring may be generally configured so as to expand radially outward to an expanded conformation when not retained in a radially contracted conformation. In an alternative embodiment (for example, in an embodiment where the outer and inner profiles are reversed, with respect to the configurations disclosed with respect to Figures 7A and 7B), a locking member may be inwardly biased. In the embodiment of Figures 7A and 7B, the locking member 710 generally

comprises an upper bevel and/or shoulder 712, a lower shoulder 714, an inner surface 716, and an outer surface 718.

[0068] In an embodiment, the outer profile 720 may be disposed within an outer surface of the sliding sleeve 126. For example, in the embodiment of Figures 7A and 7B, the outer profile is disposed in the third outer cylindrical bore surface 126q, as disclosed herein. In alternative embodiments, an outer profile like outer profile 720 may be similarly disposed within any suitable outer surface of the sliding sleeve 126, for example, at any suitable interface between the sliding sleeve 126 and the housing 120. In the embodiment of Figures 7A and 7B, the outer profile 720 generally comprises an upper bevel 722, and a lower shoulder 724. Additionally, for example, in the embodiment of Figures 7A and 7B, the outer profile also comprises an outer recessed surface 726 extending between the upper bevel 722 and the lower shoulder 724.

[0069] In an embodiment, the inner profile 730 may be disposed within an inner surface of the housing 120. For example, in the embodiment of Figures 7A and 7B, the inner profile is disposed within the third bore surface 139c of the housing 120, as disclosed herein. In alternative embodiments, an inner profile like inner profile 730 may be similarly disposed within any suitable inner surface of the housing, for example, at any suitable interface between the sliding sleeve 126 and the housing 120. In the embodiment of Figures 7A and 7B, the inner profile 730 generally comprises a an upper shoulder 731, an intermediate shoulder 733, a lower shoulder 735, a first inner recessed bore surface 732 extending between the upper shoulder 731 and the intermediate shoulder 733, and a second inner recessed bore surface 734 extending between the intermediate shoulder 733 and the lower shoulder 735. In the embodiment of Figures 7A and 7B, and as will be disclosed in greater detail herein, the first inner recessed bore surface 732 may be characterized as having a diameter greater than the diameter of the second inner recessed bore surface 734, for example, generally providing a “stair-step” like profile.

[0070] In an embodiment, when the DLA 700 is activated (e.g., as illustrated in Figure 7A), for example, while the sliding sleeve 126 is in the first position, the lower shoulder 714 of the locking member 710 engages (e.g., at least partially abuts) the lower shoulder 735 of the inner profile 730 and the upper bevel/shoulder 712 engages the upper bevel 722 of the outer profile 720. In such an embodiment, the locking member 710 is retained in the radially-inward conformation by the second inner recessed bore surface 734 (e.g., against which the outer surface 718 of the locking member 710 rests). As such, in the activated configuration, the DLA 700 may be effective to

retain the sliding sleeve 126 from movement from first position in the direction of the second position, for example, via the interaction, as disclosed herein, between the locking member 710 and the outer and inner profiles, 720 and 730, respectively. Also, when the DLA 700 is activated, the sliding sleeve 126 may be effective to hold the locking member 710 in the activated configuration; for example, the sliding sleeve 126 (e.g., the upper bevel 722 of the outer profile 720), which may be downwardly biased (e.g., by the biasing member 128, as disclosed herein), may exert a force effective to hold the locking member 710 in abutment with the inner profile (e.g., with the second inner recessed bore surface 734 and the lower shoulder 735).

[0071] Also, in an embodiment, when the DLA 700 is deactivated (e.g., as illustrated in Figure 7B), for example, by movement of the sliding sleeve 126 from the first position toward the second position as will be disclosed herein, the locking member 710 is longitudinally aligned with the first inner recessed bore surface 732, for example, such that the locking member 710 is not retained in the radially-inward conformation (e.g., by the second inner recessed bore surface 734) and, as such, the locking member 710 is allowed to expand to the radially-outward conformation, for example, such that the outer surface 718 of the locking member 710 contacts the first inner bore surface 732 of the inner profile 730. In the radially-outward conformation, the locking member 710 does not engage the sliding sleeve 126 (e.g., does not engage the outer profile 720 of the sliding sleeve 126). As such, when deactivated, the DLA 700 will allow the sliding sleeve 126 to move from the first and/or second position in the direction of the third position, for example, in that the locking member 710 does not simultaneously interact with (e.g., engage) both the outer profile 720 and the inner profile 730.

[0072] In an embodiment, the DLA 700 may be configured to be deactivated upon movement of the sliding sleeve 126 from the first position to the second position. For example, as disclosed herein, the DLA 700 generally does not impede movement of the sliding sleeve 126 from the first position in the direction of the second position. In an embodiment, upon movement of the sliding sleeve 126 from the first position in the direction of the second position (e.g., via the application of a fluid pressure to the differential in the upward-facing and downward-facing fluidly exposed surfaces of the sliding sleeve 126, as disclosed herein), the lower shoulder 724 (e.g., of the outer profile 720 of the sliding sleeve 126) may engage the lower shoulder 714 of the locking member 710 and apply a generally longitudinally upward force to the locking member 710 so as to cause the locking member 710 to become longitudinally aligned with the first inner

recessed bore surface 732. For example, upon becoming longitudinally aligned with the first inner recessed bore, the locking member 710 is not retained in the radially-inward conformation and is allowed to expand to the radially-outward conformation, for example, thereby deactivating the locking member 710.

[0073] Also, in the embodiment of Figure 4C, the sliding sleeve 126 may be retained in the third position by a locking member 130 (e.g., a snap-ring, a C-ring, a biased pin, ratchet teeth, or combinations thereof). In such an embodiment, the snap-ring (or the like) may be carried in a suitable slot, groove, channel, bore, or recess in the sliding sleeve, alternatively, in the housing, and may expand into and be received by a suitable slot groove, channel, bore, or recess in the housing, or, alternatively, in the sliding sleeve. For example, in the embodiment of Figure 4C, the locking member may be carried within a groove or channel within the sliding sleeve 126 and may expand into a locking groove 132 within the housing 120.

[0074] In an embodiment, a wellbore servicing method utilizing the PTV 100 and/or system comprising a PTV 100 is disclosed herein. In an embodiment, a wellbore servicing method may generally comprise the steps of positioning the casing string 150 comprising a PTV 100 within a wellbore 114 that penetrates the subterranean formation 102, applying a fluid pressure of at least an upper threshold within the casing string 150, and reducing the fluid pressure within the casing string 150. In an additional embodiment, a wellbore servicing method may further comprise one or more of the steps of allowing fluid to flow out of the casing string 150, communicating an obturating member (e.g., a ball or dart) via the casing string, actuating a wellbore servicing tool (e.g., a wellbore stimulation tool), stimulating a formation (e.g., fracturing, perforating, acidizing, or the like), and/or producing a formation fluid from the formation.

[0075] Referring to Figure 1, in an embodiment the wellbore servicing method comprises positioning or “running in” a casing string 150 comprising the PTV 100, for example, within a wellbore. In an embodiment, for example, as shown in Figure 1, the PTV 100 may be integrated within a casing string 150, for example, such that the PTV 100 and the casing string 150 comprise a common axial flowbore. Thus, a fluid introduced into the casing string 150 will be communicated to the PTV 100.

[0076] In the embodiment, the PTV 100 is introduced and/or positioned within a wellbore 114 (e.g., incorporated within the casing string 150) in a first configuration, for example, as shown in Figure 4A. As disclosed herein, in the first configuration, the sliding sleeve 126 is held in the

first position by at least one shear pin 134, thereby blocking fluid communication via the ports 122 of the housing 120. Also, the biasing member (e.g., spring) 128 is at least partially compressed and applies a force (e.g., a downward force) to the lower medial face 126g of the sliding sleeve 126 in the direction of the third position.

[0077] In an embodiment, positioning the PTV 100 may comprise securing the casing string with respect to the formation. For example, in the embodiment of Figure 1, positioning the casing string 150 having the PTV 100 incorporated therein may comprise cementing (so as to provide a cement sheath 116) the casing string 150 and/or deploying one or more packers (such as packers 170) at a given or desirable depth within a wellbore 114.

[0078] In an embodiment, the wellbore servicing method comprises applying a hydraulic fluid pressure within the casing string 150 by pumping a fluid into the casing via one or more typically located at the surface, such that the pressure within the casing string 150 reaches an upper threshold. In an embodiment, such an application of pressure to the casing string 150 may comprise performing a pressure test. For example, during the performance of such a pressure test, a pressure, for example, of at least an upper magnitude, may be applied to the casing string 150 for a given duration. Such a pressure test may be employed to assess the integrity of the casing string 150 and/or components incorporated therein.

[0079] In an embodiment, the application of such a hydraulic fluid pressure may be effective to transition the sliding sleeve from the first position to the second position. For example, the hydraulic fluid pressure may be applied through the axial flowbore 124, including to the sliding sleeve 126 of the PTV 100. As disclosed herein, the application of a fluid pressure to the PTV 100 may yield a force in the direction of the second position, for example, because of the differential between the force applied to the sliding sleeve in the direction toward the second position (e.g., an upward force) and the force applied to the sliding sleeve in the direction away from the second position (e.g., a downward force), for example, as provided by chamber 142.

[0080] In an embodiment, the hydraulic fluid pressure may be of a magnitude sufficient to exert a force in the direction of the second position sufficient to further compress the biasing member 128 and to shear the one or more shear pins 134, thereby causing the sliding sleeve 126 to move relative to the housing 120 in the direction of the first position, thereby transitioning the sliding sleeve 126 from the first position to the second position. In an embodiment, the sliding sleeve may continue to move in the direction of the second position until the upper shoulder face

126d of the sliding sleeve 126 contacts and/or abuts the upper shoulder 138a of the recess 138, thereby prohibiting the sliding sleeve 126 from continuing to slide.

[0081] In an embodiment, the upper threshold pressure may be at least about 8,000 p.s.i., alternatively, at least about 10,000 p.s.i., alternatively, at least about 12,000 p.s.i., alternatively, at least about 15,000 p.s.i., alternatively, at least about 18,000 p.s.i., alternatively, at least about 20,000 p.s.i., alternatively, any suitable pressure about equal to or less than the pressure at which the casing string 150 is rated.

[0082] Additionally, in an embodiment where the PTV (such as PTV 101, disclosed herein) comprises a DLA (such as DLA 700, disclosed herein), the wellbore servicing method may further comprise deactivating the DLA 700. For example, the DLA 700 may be initially provided in an activated configuration, for example, so as to inhibit movement of the sliding sleeve 126 from the first position in the direction of the third position. In such an embodiment, deactivating the DLA 700 may comprise causing the sliding sleeve 126 to move from the first position in the direction of the second position. As disclosed herein, upon movement of the sliding sleeve 126 from the first position in the direction of the second position (e.g., via the application of a fluid pressure to the differential in the upward-facing and downward-facing fluidically exposed surfaces of the sliding sleeve 126, as disclosed herein), the locking member 710 will be allowed to expand to the radially-outward conformation, for example, thereby deactivating the locking member 710. In an embodiment, and not intending to be bound by theory, the presence of a DLA (such as DLA 700) may aid in the movement of the sliding sleeve 126. For example, because the DLA 700 only impedes movement of the sliding sleeve 126 in the direction from the first position toward the third position (but not from the first position toward the second position), the DLA 700 may allow frangible members (e.g., shears pins 134) having a lesser failure rating to be used (relative to otherwise similar tools not having a DLA) or, alternatively, may allow such frangible members to not be used at all (e.g., to retain the sliding sleeve 126 from movement from the first position to the third position). Also, the presence of a DLA may allow a biasing member (e.g., biasing member 128) exerting a greater force (relative to otherwise similar tools not having a DLA) to be utilized. For example, because the DLA 700 selectively impedes movement of the sliding sleeve 126 in the direction from the first position toward the third position, the force associated with the biasing member 128 may be increased without the risk that the biasing member will inadvertently overcome the shear pins 134.

[0083] In an embodiment, the wellbore servicing method comprises allowing the application of pressure within casing string 150 and/or the PTV 100 to fall below a lower threshold. For example, upon completion of the pressure test, for example, having assessed the integrity of the casing string 150, the pressure applied to the casing string 150 maybe allowed to subside. In an embodiment, upon allowing the pressure within the casing string to fall below the lower threshold, the force exerted by the biasing member 128 against the sliding sleeve (e.g., against the third medial face 126g in the direction toward the third position is greater than the force due to hydraulic fluid pressure in the direction away from the third position (e.g., the force applied by the biasing spring 128 overcomes any frictional forces and any forces due to hydraulic fluid pressure), thereby causing the sliding sleeve 126 to move in the direction of the third position, for example until the fourth medial shoulder 126k comes to rest against the lower shoulder 138b of the recess 138, thereby transitioning the sliding sleeve 126 from the second position to the third position.

[0084] In an embodiment, the lower threshold may be less than about 6,000 p.s.i., alternatively, less than about 5,000 p.s.i., alternatively, less than about 4,000 p.s.i., alternatively, less than about 3,000 p.s.i., alternatively, less than about 2,000 p.s.i., alternatively, less than about 1,000 p.s.i., alternatively, less than about 500 p.s.i., alternatively, about 0 p.s.i..

[0085] In an embodiment, the sliding sleeve slides in the direction of the third position until the locking member 130 (e.g., a snap ring, a lock ring, a ratchet teeth, or the like) of the sliding sleeve 126 engages with an adjacent the locking groove 132 (e.g., groove, a channel, a dog, a catch, or the like) within/along the fourth bore surface 139d of the housing 120, thereby preventing or restricting the sliding sleeve 126 from further movement (e.g., from moving out of the third position). Thus, the sliding sleeve 126 is retained in the third position in which the ports 122 of the housing 120 are no longer blocked, thereby allowing fluid communication out of the casing string 150 (e.g., to the wellbore 114, the subterranean formation 102, or both) via the ports 122 of the housing 120.

[0086] In an embodiment, following the transitioning of the sliding sleeve 126 into the third position, fluid may be allowed to escape the axial flowbore 115 of the casing 150 and the axial flowbore 124 of the PTV 100 via the ports 122 of the PTV 100. In such an embodiment, allowing fluid to escape from the casing string 150 may allow an obturating member may be introduced within the casing string 150 and communicated therethrough, for example, so as to engage with a

suitable obturating member retainer (e.g., a seat) within a wellbore servicing tool incorporated within the casing string 150, thereby allowing actuation of such a wellbore servicing tool (e.g., opening of one or more ports, sliding sleeves, windows, etc., within a fracturing and/or perforating tool) for the performance of a formation servicing operation, for example, a formation stimulation operation, such as a fracturing, perforating, acidizing, or like stimulation operation.

[0087] In an embodiment, a wellbore servicing operation may further comprise performing a formation stimulation operation, for example, via one or more wellbore servicing tools incorporated within the casing string. Further still, following the completion of such formation stimulation operations, the wellbore servicing method may further comprise producing a formation fluid (for example, a hydrocarbon, such as oil and/or gas) from the formation via the wellbore.

[0088] Additionally, in an embodiment where the PTV (such as PTV 101, disclosed herein) comprises a FPA (such as FPA 600, disclosed herein), the wellbore servicing method may further comprise activating the FPA 600. For example, the FPA 600 may be initially provided in an unactivated (e.g., a not yet activated) state. In such an embodiment, activating the FPA 600 may generally comprise pressurizing the axial flowbore 124, followed by depressurizing the axial flowbore 124. For example, as disclosed herein, upon the application of pressure (e.g., a pressure of at least the upper threshold, as disclosed herein), followed by the allowing the pressure applied to the axial flowbore 124 to dissipate, the FPA 600 may yield a generally downward force. In such an embodiment, the downward force may be applied to the sliding sleeve 126 (e.g., via the interaction between the floating piston 610 and the upwardly-facing shoulder 126s of the sliding sleeve 126) such that the sliding sleeve 126 experiences an additional downward force upon the activation of the FPA 600.

[0089] In an embodiment, and not intending to be bound by theory, the presence of a FPA (such as FPA 600) may aid in the movement of the sliding sleeve 126. For example, as disclosed herein the upon activation, the FPA applies an additional force to the sliding sleeve 126 to transition the sliding sleeve 126 from the second position to the third position.

[0090] In an embodiment, a PTV 100, a system comprising a PTV 100, and/or a wellbore servicing method employing such a system and/or a PTV 100, as disclosed herein or in some portion thereof, may be advantageously employed in pressure testing a casing string. For example, in an embodiment, a PTV like PTV 100 enables a casing string to be safely pressurized (e.g., tested) at a desired pressure, but does not require that such test pressure be exceeded following the

pressure test in order to transition open a valve. For example, because PTV 100 can be configured to transitioned from the first configuration to the second configuration, as disclosed herein, upon any suitable pressure and because the PTV 100 does not allow fluid communication until the fluid pressure has subsided, a PTV as disclosed herein may be opened without exceeding the maximum value of the pressure test.

[0091] As may be appreciated by one of skill in the art, conventional methods of providing fluid communication following a pressure testing a casing string require, following the pressure test, over-pressuring a casing string to shear one or more shear pins and thereby enable fluid communication from the axial flowbore of the casing string to the wellbore formation. As such, conventional tools, systems, and/or methods do not provide a way to ensure the opening of one or more ports without the use of pressure levels which would generally exceed the maximal pressures used during pressure testing. Therefore, the methods disclosed herein provide a means by which pressure testing of a casing string can be performed only requiring pressure levels within the standard pressure testing levels.

ADDITIONAL DISCLOSURE

[0092] The following are nonlimiting, specific embodiments in accordance with the present disclosure:

[0093] A first embodiment, which is a wellbore servicing system comprising:
a casing string; and
a pressure testing valve, the pressure testing valve incorporated within the casing string and comprising:

a housing comprising one or more ports and an axial flowbore; and

a sliding sleeve, wherein the sliding sleeve is slidably positioned within the housing and transitional from:

a first position to a second position, and from the second position to a third position;

wherein, when the sliding sleeve is in the first position and the second position, the sliding sleeves blocks a route of fluid communication via the one or more ports and, when the sliding sleeve is in the third position the sliding sleeve does not block the route of fluid communication via the one or more ports;

wherein the pressure testing valve is configured such that application of a fluid pressure of at least an upper threshold to the axial flowbore causes the sliding sleeve to transition from the first position to the second position; and

wherein the pressure testing valve is configured such that a reduction of the fluid pressure to not more than a lower threshold applied to the axial flowbore causes the sliding sleeve to transition from the second position to the third position; and

a floating piston assembly slidably disposed between the housing and the sliding sleeve, wherein the floating piston assembly is configured such that,

when unactivated, the floating piston assembly will not apply a force to the sliding sleeve in either the direction of the second position or in the direction of the third position, and

when activated, the floating piston assembly will apply a force to the sliding sleeve in the direction of the third position.

[0094] A second embodiment, which is the wellbore servicing system of the first embodiment, wherein the floating piston assembly comprises a floating piston slidably disposed between the sliding sleeve and the housing.

[0095] A third embodiment, which is the wellbore servicing system of the second embodiment, wherein the sliding sleeve comprises a unidirectional valve, wherein the unidirectional valve is configured to allow fluid communication from the axial flowbore to an upper orthogonal surface of the floating piston.

[0096] A fourth embodiment, which is the wellbore servicing system of the third embodiment, wherein a lower orthogonal surface of the floating piston is fluidically exposed to the axial flowbore.

[0097] A fifth embodiment, which is the wellbore servicing system of one of the first through the fourth embodiments, wherein the floating piston assembly is configured to be activated upon the application of a fluid pressure of at least an upper threshold to the axial flowbore followed by the reduction of the fluid pressure to not more than a lower threshold applied to the axial flowbore.

[0098] A sixth embodiment, which is the wellbore servicing system of one of the first through the fifth embodiments, wherein the sliding sleeve is biased in the direction of the third position.

[0099] A seventh embodiment, which is the wellbore servicing system of the sixth embodiment, wherein the pressure testing valve comprises a spring, wherein the spring is configured to bias the sliding sleeve towards the third position.

[00100] An eighth embodiment, which is the wellbore servicing system of one of the first through the seventh embodiments, wherein the pressure testing valve comprises one or more frangible members configured to restrain the sliding sleeve in the first position.

[00101] A ninth embodiment, which is the wellbore servicing system of one of the first through the eighth embodiments, wherein the pressure testing valve comprises a locking system comprising a lock and locking groove configured to retain the sliding sleeve in the third position.

[00102] A tenth embodiment, which is the wellbore servicing system of one of the first through the ninth embodiments, where the pressure testing valve comprises a differential area chamber, wherein the differential area chamber is not fluidically exposed to the axial flowbore.

[00103] An eleventh embodiment, which is the wellbore servicing system of the tenth embodiment, wherein the differential area comprises of one or more o-rings.

[00104] A twelfth embodiment, which is the wellbore servicing system of one of the first through the eleventh embodiments, wherein the upper threshold is at least about 15,000 p.s.i.

[00105] A thirteenth embodiment, which is the wellbore servicing system of one of the first through the twelfth embodiments, wherein the lower threshold is not more than about 5,000 p.s.i.

[00106] A fourteenth embodiment, which is a wellbore servicing method comprising:
positioning casing string having a pressure testing valve incorporated therein within a wellbore penetrating the subterranean formation, wherein the pressure testing valve comprises:

a housing comprising one or more ports and an axial flowbore;

a sliding sleeve, wherein the sliding sleeve is slidably positioned within the housing, wherein the sliding sleeve is configured to block a route of fluid communication via one or more ports when the casing string is positioned within the wellbore; and

a floating piston assembly slidably disposed between the housing and the sliding sleeve, wherein the floating piston assembly is configured so as to not apply longitudinal force to the sliding sleeve;

applying a fluid pressure of at least an upper threshold to the axial flowbore, wherein, upon application of the fluid pressure of at least the upper threshold, the sliding sleeve continues to block the route of fluid communication and the floating piston assembly continues to not apply a longitudinal force to the sliding sleeve; and

reducing the fluid pressure to not more than a lower threshold, wherein, upon reduction of the fluid pressure to not more than the lower threshold, the sliding sleeve allows fluid communication via one or more ports of the housing and the floating piston assembly applies a downward force to the sliding sleeve.

[00107] A fifteenth embodiment, which is the method of the fourteenth embodiment, wherein the floating piston assembly comprises a floating piston slidably disposed between the sliding sleeve and the housing.

[00108] A sixteenth embodiment, which is the method of the fifteenth embodiment, wherein upon application of the fluid pressure of at least the upper threshold and reduction of the fluid pressure to not more than the lower threshold, a fluid pressure applied to an upper orthogonal surface of the floating piston is greater than a fluid pressure applied to a lower orthogonal surface of the floating piston.

[00109] A seventeenth embodiment, which is a wellbore servicing tool comprising:

a housing comprising an axial flowbore; and

a sliding sleeve, wherein the sliding sleeve is slidably, longitudinally movable within the housing; and

a floating piston assembly slidably disposed between the housing and the sliding sleeve, wherein the floating piston is configured such that,

when unactivated, the floating piston assembly will not apply a force to the sliding sleeve in either a first longitudinal direction or a second longitudinal direction, and

when activated, the floating piston assembly will apply a force to the sliding sleeve in the first longitudinal direction.

[00110] An eighteenth embodiment, which is the wellbore servicing tool of the seventeenth embodiment, wherein the floating piston assembly is configured to be activated upon the application of a fluid pressure to the axial flowbore followed by the reduction of the fluid pressure applied to the axial flowbore.

[00111] A nineteenth embodiment, which is the wellbore servicing tool of one of the seventeenth through the eighteenth embodiments, wherein the floating piston assembly comprises a floating piston slidably disposed between the sliding sleeve and the housing.

[00112] A twentieth embodiment, which is the wellbore servicing tool of the nineteenth embodiment, wherein the sliding sleeve comprises a unidirectional valve, wherein the unidirectional valve is configured to allow fluid communication from the axial flowbore to a first orthogonal surface of the floating piston.

[00113] A twenty-first embodiment, which is the wellbore servicing tool of the twentieth embodiment, wherein a second orthogonal surface of the floating piston is fluidically exposed to the axial flowbore.

[00114] A twenty-second embodiment, which is a wellbore servicing system comprising:
a casing string; and
a pressure testing valve, the pressure testing valve incorporated within the casing string and comprising:
a housing comprising one or more ports and an axial flowbore; and
a sliding sleeve, wherein the sliding sleeve is slidably positioned within the housing and transitional from:
a first position to a second position, and from the second position to a third position;

wherein, when the sliding sleeve is in the first position and the second position, the sliding sleeves blocks a route of fluid communication via the one or more ports and, when the sliding sleeve is in the third position the sliding sleeve does not block the route of fluid communication via the one or more ports;

wherein the pressure testing valve is configured such that application of a fluid pressure of at least an upper threshold to the

axial flowbore causes the sliding sleeve to transition from the first position to the second position; and

wherein the pressure testing valve is configured such that a reduction of the fluid pressure to not more than a lower threshold applied to the axial flowbore causes the sliding sleeve to transition from the second position to the third position; and

a deactivatable locking assembly disposed between the housing and the sliding sleeve, wherein the deactivatable locking assembly is configured such that,

when activated, the deactivatable locking assembly will inhibit movement of the sliding sleeve in the direction of the third position, and

when deactivated, the deactivatable locking assembly will not inhibit movement of the sliding sleeve in the direction of the third position.

[00115] A twenty-third embodiment, which is the wellbore servicing system of the twenty-second embodiment, wherein the deactivatable locking assembly comprises:

an outer profile, wherein the outer profile is disposed on an outer surface of the sliding sleeve;

an inner profile, wherein the inner profile is disposed on an inner surface of the housing; and

a locking member disposed between the sliding sleeve and the housing.

[00116] A twenty-fourth embodiment, which is the wellbore servicing system of the twenty-third embodiment,

wherein the outer profile comprises an upward-facing, lower shoulder and an upper bevel,

wherein the inner profile comprises a downward-facing upper shoulder, an upward-facing intermediate shoulder, an upward-facing lower shoulder, a first cylindrical surface extending between the upper shoulder and the intermediate shoulder, and a second cylindrical surface extending between the intermediate shoulder and the lower shoulder, and

wherein the locking member comprises a outwardly biased ring.

[00117] A twenty-fifth embodiment, which is the wellbore servicing system of the twenty-fourth embodiment, wherein, when the deactivatable locking assembly is activated, the locking member engages the lower shoulder of the inner profile and the upper bevel of the outer profile.

[00118] A twenty-sixth embodiment, which is the wellbore servicing system of one of the twenty-fourth through the twenty-fifth embodiments, wherein, when the deactivatable locking assembly is deactivated, the locking member engages only one of the outer profile and the inner profile.

[00119] A twenty-seventh embodiment, which is the wellbore servicing system of one of the twenty-fourth through the twenty-sixth embodiments,

wherein the first cylindrical surface of the inner profile is characterized as having a diameter greater than the second cylindrical surface of the inner profile

wherein, when the locking member is aligned with the second cylindrical surface, the deactivatable locking assembly is activated, and

wherein, when the locking member is aligned with the first cylindrical surface, the deactivatable locking assembly is deactivated.

[00120] A twenty-eighth embodiment, which is the wellbore servicing system of one of the twenty-second through the twenty-seventh embodiments, wherein the deactivatable locking assembly is configured to be deactivated upon the movement of the sliding sleeve from the first position in the direction of the second position.

[00121] A twenty-ninth embodiment, which is the wellbore servicing system of one of the twenty-second through the twenty-eighth embodiments, wherein the sliding sleeve is biased in the direction of the third position.

[00122] A thirtieth embodiment, which is the wellbore servicing system of the twenty-ninth embodiment, wherein the pressure testing valve comprises a spring, wherein the spring is configured to bias the sliding sleeve towards the third position.

[00123] A thirty-first embodiment, which is the wellbore servicing system of one of the twenty-second through the thirtieth embodiments, wherein the pressure testing valve comprises one or more frangible members configured to restrain the sliding sleeve in the first position.

[00124] A thirty-second embodiment, which is the wellbore servicing system of one of the twenty-second through the thirty-first embodiments, wherein the pressure testing valve

comprises a locking system comprising a lock and locking groove configured to retain the sliding sleeve in the third position.

[00125] A thirty-third embodiment, which is the wellbore servicing system of one of the twenty-second through the thirty second embodiments, where the pressure testing valve comprises a differential area chamber, wherein the differential area chamber is not fluidically exposed to the axial flowbore.

[00126] A thirty-fourth embodiment, which is the wellbore servicing system of the thirty-third embodiment, wherein the differential area comprises of one or more o-rings.

[00127] A thirty-fifth embodiment, which is the wellbore servicing system of one of the twenty-second through the thirty-fourth embodiments, wherein the upper threshold is at least about 15,000 p.s.i.

[00128] A thirty-sixth embodiment, which is the wellbore servicing system of one of the twenty-second through the thirty-fifth embodiments, wherein the lower threshold is not more than about 5,000 p.s.i.

[00129] A thirty-seventh embodiment, which is a wellbore servicing method comprising:
positioning casing string having a pressure testing valve incorporated therein within a wellbore penetrating the subterranean formation, wherein the pressure testing valve comprises:

a housing comprising one or more ports and an axial flowbore;

a sliding sleeve, wherein the sliding sleeve is slidably positioned within the housing in a first position in which the sliding sleeve is configured to block a route of fluid communication via one or more ports when the casing string is positioned within the wellbore; and

a deactivatable locking assembly disposed between the housing and the sliding sleeve, wherein the deactivatable locking assembly is configured so as to inhibit movement of the sliding sleeve in the direction of a third position;

applying a fluid pressure of at least an upper threshold to the axial flowbore, wherein, upon application of the fluid pressure of at least the upper threshold, the sliding sleeve transitions to a second position in which the sliding sleeve continues to block the route of fluid communication, and wherein, upon movement of the sliding sleeve from the first position in the direction of the second position, the deactivatable locking

assembly is configured so as to not inhibit movement of the sliding sleeve in the direction of a third position; and

reducing the fluid pressure to not more than a lower threshold, wherein, upon reduction of the fluid pressure to not more than the lower threshold, the sliding sleeve transitions to a third position in which the sliding sleeve allows fluid communication via one or more ports of the housing.

[00130] A thirty-eighth embodiment, which is the method of the thirty-seventh embodiment, wherein the floating piston assembly comprises:

an outer profile, wherein the outer profile is disposed on an outer surface of the sliding sleeve;

an inner profile, wherein the inner profile is disposed on an inner surface of the housing; and

a locking member disposed between the sliding sleeve and the housing.

[00131] A thirty-ninth embodiment, which is a wellbore servicing tool comprising:

a housing comprising an axial flowbore; and

a sliding sleeve, wherein the sliding sleeve is slidably, longitudinally movable within the housing; and

a deactivatable locking assembly disposed between the housing and the sliding sleeve, wherein the deactivatable locking assembly is configured such that,

when activated, the deactivatable locking assembly will inhibit movement of the sliding sleeve in a first longitudinal direction and will not inhibit movement in a second longitudinal direction, wherein the first direction is generally opposite of the second direction, and

when deactivated, the deactivatable locking assembly will not inhibit movement of the sliding sleeve the first direction.

[00132] A fortieth embodiment, which is the wellbore servicing tool of the thirty-ninth embodiment, wherein the deactivatable locking assembly comprises:

an outer profile, wherein the outer profile is disposed on an outer surface of the sliding sleeve;

an inner profile, wherein the inner profile is disposed on an inner surface of the housing; and

a locking member disposed between the sliding sleeve and the housing.

[00133] A forty-first embodiment, which is the wellbore servicing tool of the fortieth embodiment, wherein the inner profile comprises a first cylindrical surface and a second cylindrical surface, wherein the first cylindrical surface of the inner profile is characterized as having a diameter greater than the second cylindrical surface of the inner profile, and wherein the locking member comprises a outwardly biased ring.

[00134] A forty-second embodiment, which is the wellbore servicing tool of the forty-first embodiment,

wherein, when the locking member is aligned with the second cylindrical surface, the deactivatable locking assembly is activated, and

wherein, when the locking member is aligned with the first cylindrical surface, the deactivatable locking assembly is deactivated.

[00135] A forty-third embodiment, which is the wellbore servicing tool of one of the forty-first through the forty-second embodiments, wherein the first cylindrical surface of the inner profile is characterized as being located in the second direction relative to the second cylindrical surface of the inner profile.

[00136] A forty-fourth embodiment, which is the wellbore servicing system of one of the thirty-ninth through the forty-third embodiments, wherein the deactivatable locking assembly is configured to be deactivated upon the movement of the sliding sleeve in the second direction.

[00137] A forty-fifth embodiment, which is the wellbore servicing system of one of the thirty-ninth through the forty-fourth embodiments, wherein the sliding sleeve is biased in the first direction.

[00138] While embodiments of the invention have been shown and described, modifications thereof can be made by one skilled in the art without departing from the spirit and teachings of the invention. The embodiments described herein are exemplary only, and are not intended to be limiting. Many variations and modifications of the invention disclosed herein are possible and are within the scope of the invention. Where numerical ranges or limitations are expressly stated, such express ranges or limitations should be understood to include iterative ranges or limitations of like magnitude falling within the expressly stated ranges or limitations (e.g., from about 1 to about 10 includes, 2, 3, 4, etc.; greater than 0.10 includes 0.11, 0.12, 0.13, etc.). For example, whenever a numerical range with a lower limit, R_l , and an upper limit, R_u , is disclosed, any number falling

within the range is specifically disclosed. In particular, the following numbers within the range are specifically disclosed: $R = R_l + k * (R_u - R_l)$, wherein k is a variable ranging from 1 percent to 100 percent with a 1 percent increment, i.e., k is 1 percent, 2 percent, 3 percent, 4 percent, 5 percent, 50 percent, 51 percent, 52 percent,, 95 percent, 96 percent, 97 percent, 98 percent, 99 percent, or 100 percent. Moreover, any numerical range defined by two R numbers as defined in the above is also specifically disclosed. Use of the term "optionally" with respect to any element of a claim is intended to mean that the subject element is required, or alternatively, is not required. Both alternatives are intended to be within the scope of the claim. Use of broader terms such as comprises, includes, having, etc. should be understood to provide support for narrower terms such as consisting of, consisting essentially of, comprised substantially of, etc.

[00139] Accordingly, the scope of protection is not limited by the description set out above but is only limited by the claims which follow, that scope including all equivalents of the subject matter of the claims. Each and every claim is incorporated into the specification as an embodiment of the present invention. Thus, the claims are a further description and are an addition to the embodiments of the present invention. The discussion of a reference in the Detailed Description of the Embodiments is not an admission that it is prior art to the present invention, especially any reference that may have a publication date after the priority date of this application. The disclosures of all patents, patent applications, and publications cited herein are hereby incorporated by reference, to the extent that they provide exemplary, procedural or other details supplementary to those set forth herein.

CLAIMS

What is claimed is:

1. A wellbore servicing system comprising:
 - a casing string; and
 - a pressure testing valve, the pressure testing valve incorporated within the casing string and comprising:
 - a housing comprising one or more ports and an axial flowbore; and
 - a sliding sleeve, wherein the sliding sleeve is slidably positioned within the housing and transitional from:
 - a first position to a second position, and from the second position to a third position;
 - wherein, when the sliding sleeve is in the first position and the second position, the sliding sleeves blocks a route of fluid communication via the one or more ports and, when the sliding sleeve is in the third position the sliding sleeve does not block the route of fluid communication via the one or more ports;
 - wherein the pressure testing valve is configured such that application of a fluid pressure of at least an upper threshold to the axial flowbore causes the sliding sleeve to transition from the first position to the second position; and
 - wherein the pressure testing valve is configured such that a reduction of the fluid pressure to not more than a lower threshold applied to the axial flowbore causes the sliding sleeve to transition from the second position to the third position; and
 - a deactivatable locking assembly disposed between the housing and the sliding sleeve, wherein the deactivatable locking assembly is configured such that,
 - when activated, the deactivatable locking assembly will inhibit movement of the sliding sleeve in the direction of the third position, and
 - when deactivated, the deactivatable locking assembly will not inhibit movement of the sliding sleeve in the direction of the third position.

2. The wellbore servicing system of claim 1, wherein the deactivatable locking assembly comprises:
 - an outer profile, wherein the outer profile is disposed on an outer surface of the sliding sleeve;
 - an inner profile, wherein the inner profile is disposed on an inner surface of the housing; and
 - a locking member disposed between the sliding sleeve and the housing.
3. The wellbore servicing system of claim 2,
 - wherein the outer profile comprises an upward-facing, lower shoulder and an upper bevel,
 - wherein the inner profile comprises a downward-facing upper shoulder, an upward-facing intermediate shoulder, an upward-facing lower shoulder, a first cylindrical surface extending between the upper shoulder and the intermediate shoulder, and a second cylindrical surface extending between the intermediate shoulder and the lower shoulder, and
 - wherein the locking member comprises a outwardly biased ring.
4. The wellbore servicing system of claim 3, wherein, when the deactivatable locking assembly is activated, the locking member engages the lower shoulder of the inner profile and the upper bevel of the outer profile.
5. The wellbore servicing system of any of claims 3-4, wherein, when the deactivatable locking assembly is deactivated, the locking member engages only one of the outer profile and the inner profile.
6. The wellbore servicing system of any of claims 3-5,
 - wherein the first cylindrical surface of the inner profile is characterized as having a diameter greater than the second cylindrical surface of the inner profile
 - wherein, when the locking member is aligned with the second cylindrical surface, the deactivatable locking assembly is activated, and
 - wherein, when the locking member is aligned with the first cylindrical surface, the deactivatable locking assembly is deactivated.

7. The wellbore servicing system of any of claims 1-6, wherein the deactivatable locking assembly is configured to be deactivated upon the movement of the sliding sleeve from the first position in the direction of the second position.
8. The wellbore servicing system of any of claims 1-7, wherein the sliding sleeve is biased in the direction of the third position.
9. The wellbore servicing system of claim 8, wherein the pressure testing valve comprises a spring, wherein the spring is configured to bias the sliding sleeve towards the third position.
10. The wellbore servicing system of any of claims 1-9, wherein the pressure testing valve comprises one or more frangible members configured to restrain the sliding sleeve in the first position.
11. The wellbore servicing system of any of claims 1-10, wherein the pressure testing valve comprises a locking system comprising a lock and locking groove configured to retain the sliding sleeve in the third position.
12. The wellbore servicing system of any of claims 1-11, where the pressure testing valve comprises a differential area chamber, wherein the differential area chamber is not fluidically exposed to the axial flowbore.
13. The wellbore servicing system of claim 12, wherein the differential area comprises of one or more o-rings.
14. The wellbore servicing system of any of claims 1-13, wherein the upper threshold is at least about 15,000 p.s.i.
15. The wellbore servicing system of any of claims 1-14, wherein the lower threshold is not more than about 5,000 p.s.i.
16. A wellbore servicing method comprising:
 - positioning casing string having a pressure testing valve incorporated therein within a wellbore penetrating the subterranean formation, wherein the pressure testing valve comprises:
 - a housing comprising one or more ports and an axial flowbore;
 - a sliding sleeve, wherein the sliding sleeve is slidably positioned within the housing in a first position in which the sliding sleeve is configured to block a route of fluid communication via one or more ports when the casing string is positioned within the wellbore; and

a deactivatable locking assembly disposed between the housing and the sliding sleeve, wherein the deactivatable locking assembly is configured so as to inhibit movement of the sliding sleeve in the direction of a third position;

applying a fluid pressure of at least an upper threshold to the axial flowbore, wherein, upon application of the fluid pressure of at least the upper threshold, the sliding sleeve transitions to a second position in which the sliding sleeve continues to block the route of fluid communication, and wherein, upon movement of the sliding sleeve from the first position in the direction of the second position, the deactivatable locking assembly is configured so as to not inhibit movement of the sliding sleeve in the direction of a third position; and

reducing the fluid pressure to not more than a lower threshold, wherein, upon reduction of the fluid pressure to not more than the lower threshold, the sliding sleeve transitions to a third position in which the sliding sleeve allows fluid communication via one or more ports of the housing.

17. The method of claim 16, wherein the floating piston assembly comprises:

an outer profile, wherein the outer profile is disposed on an outer surface of the sliding sleeve;

an inner profile, wherein the inner profile is disposed on an inner surface of the housing; and

a locking member disposed between the sliding sleeve and the housing.

18. A wellbore servicing tool comprising:

a housing comprising an axial flowbore; and

a sliding sleeve, wherein the sliding sleeve is slidably, longitudinally movable within the housing; and

a deactivatable locking assembly disposed between the housing and the sliding sleeve, wherein the deactivatable locking assembly is configured such that,

when activated, the deactivatable locking assembly will inhibit movement of the sliding sleeve in a first longitudinal direction and will not inhibit movement in a second longitudinal direction, wherein the first direction is generally opposite of the second direction, and

when deactivated, the deactivatable locking assembly will not inhibit movement of the sliding sleeve the first direction.

19. The wellbore servicing tool of claim 18, wherein the deactivatable locking assembly comprises:

an outer profile, wherein the outer profile is disposed on an outer surface of the sliding sleeve;

an inner profile, wherein the inner profile is disposed on an inner surface of the housing; and

a locking member disposed between the sliding sleeve and the housing.

20. The wellbore servicing tool of the claim 19, wherein the inner profile comprises a first cylindrical surface and a second cylindrical surface, wherein the first cylindrical surface of the inner profile is characterized as having a diameter greater than the second cylindrical surface of the inner profile, and wherein the locking member comprises a outwardly biased ring.

21. The wellbore servicing tool of claim 20,

wherein, when the locking member is aligned with the second cylindrical surface, the deactivatable locking assembly is activated, and

wherein, when the locking member is aligned with the first cylindrical surface, the deactivatable locking assembly is deactivated.

22. The wellbore servicing tool of any of claims 20-21, wherein the first cylindrical surface of the inner profile is characterized as being located in the second direction relative to the second cylindrical surface of the inner profile.

23. The wellbore servicing system of any of claims 18-22, wherein the deactivatable locking assembly is configured to be deactivated upon the movement of the sliding sleeve in the second direction.

24. The wellbore servicing system of any of claims 18-23, wherein the sliding sleeve is biased in the first direction.

FIG. 1

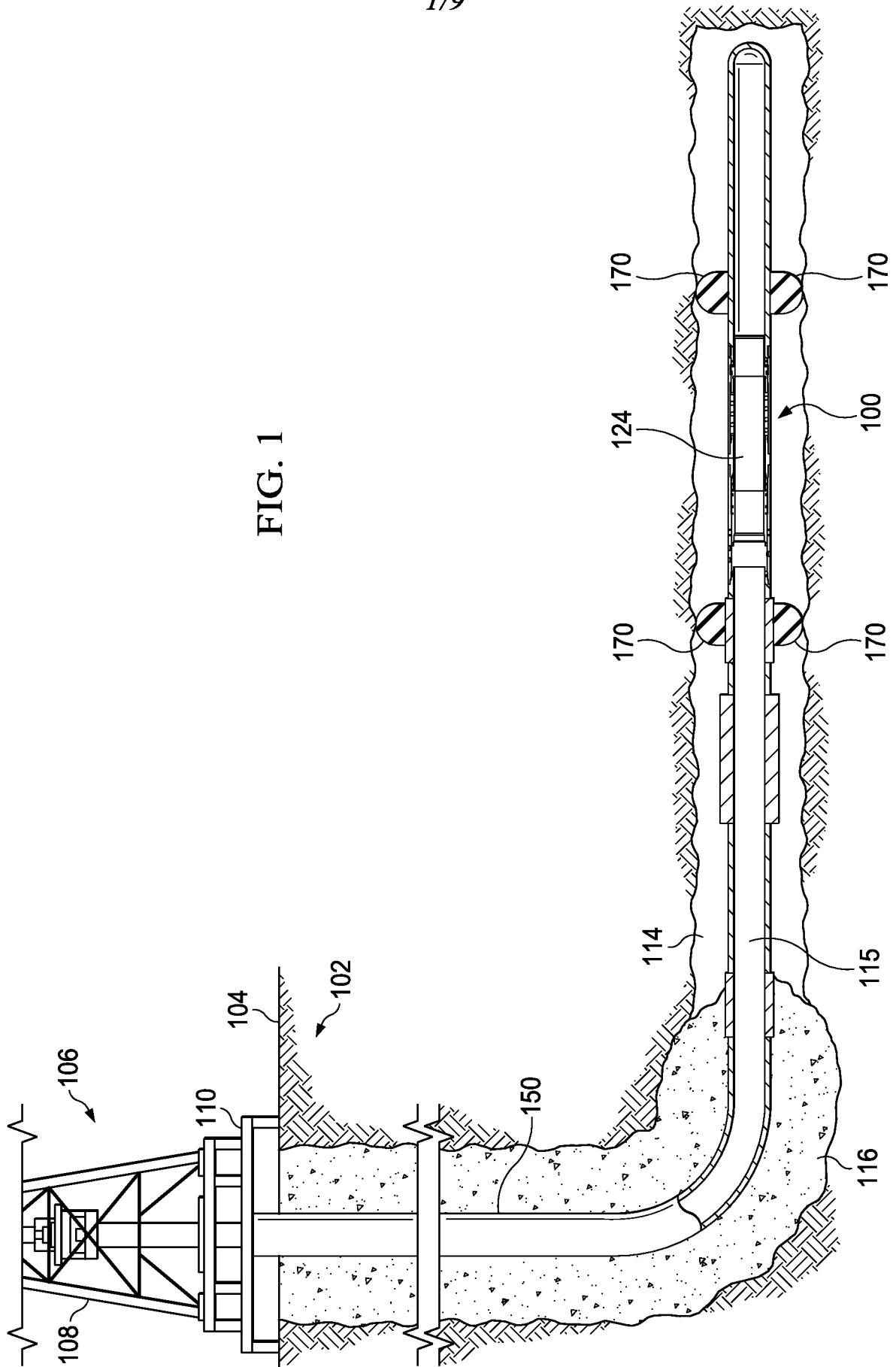

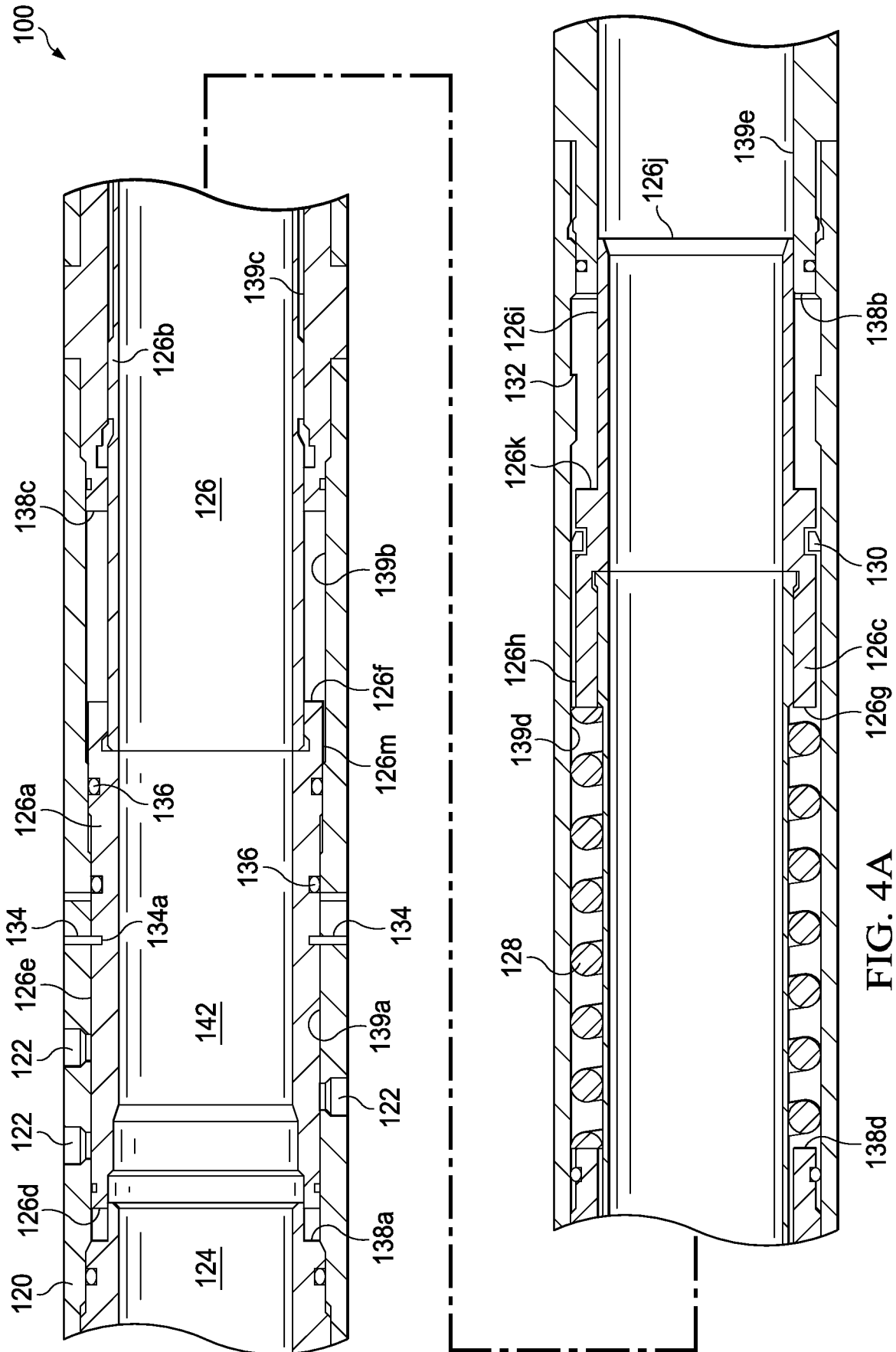
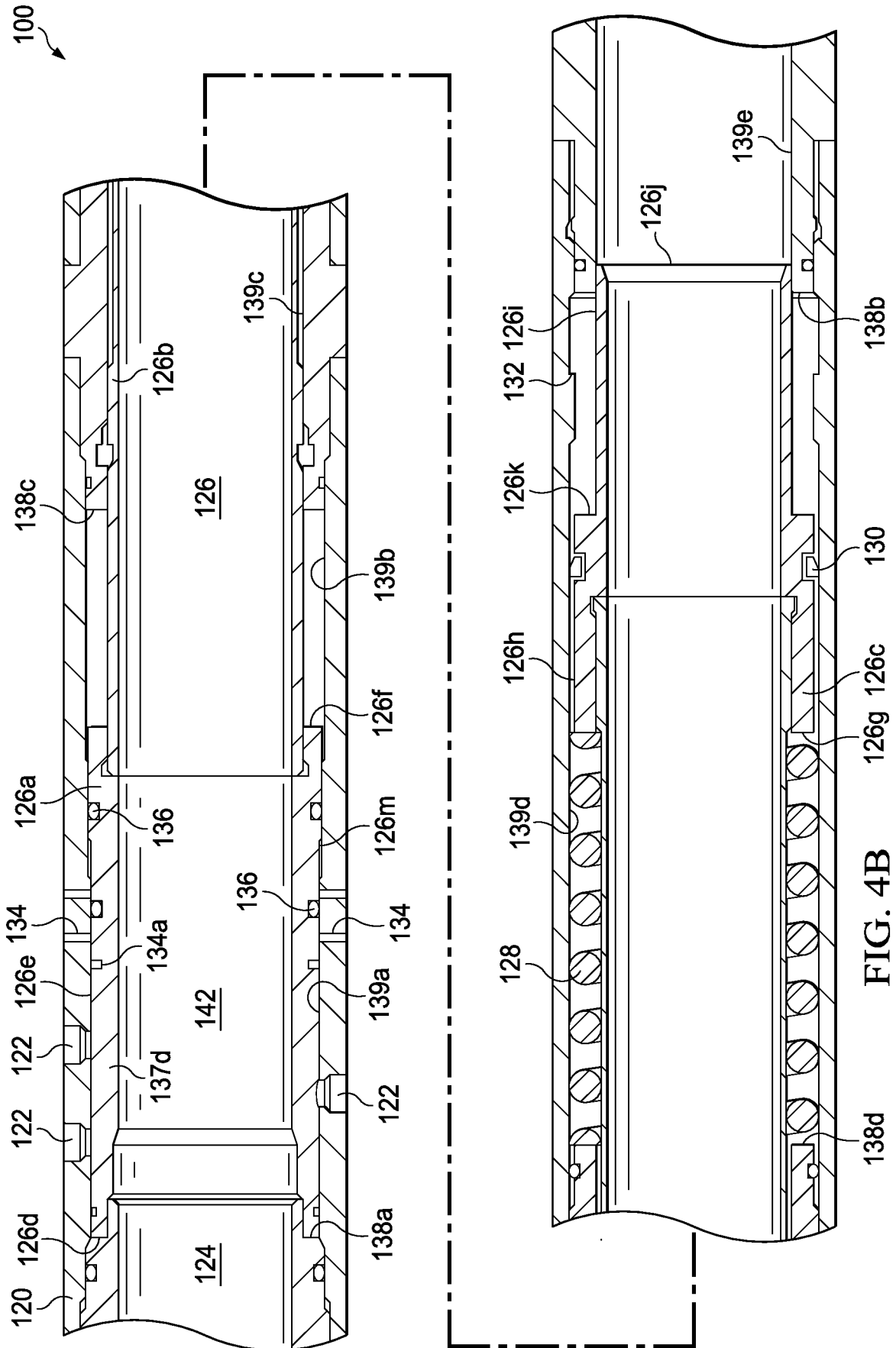

FIG. 4A



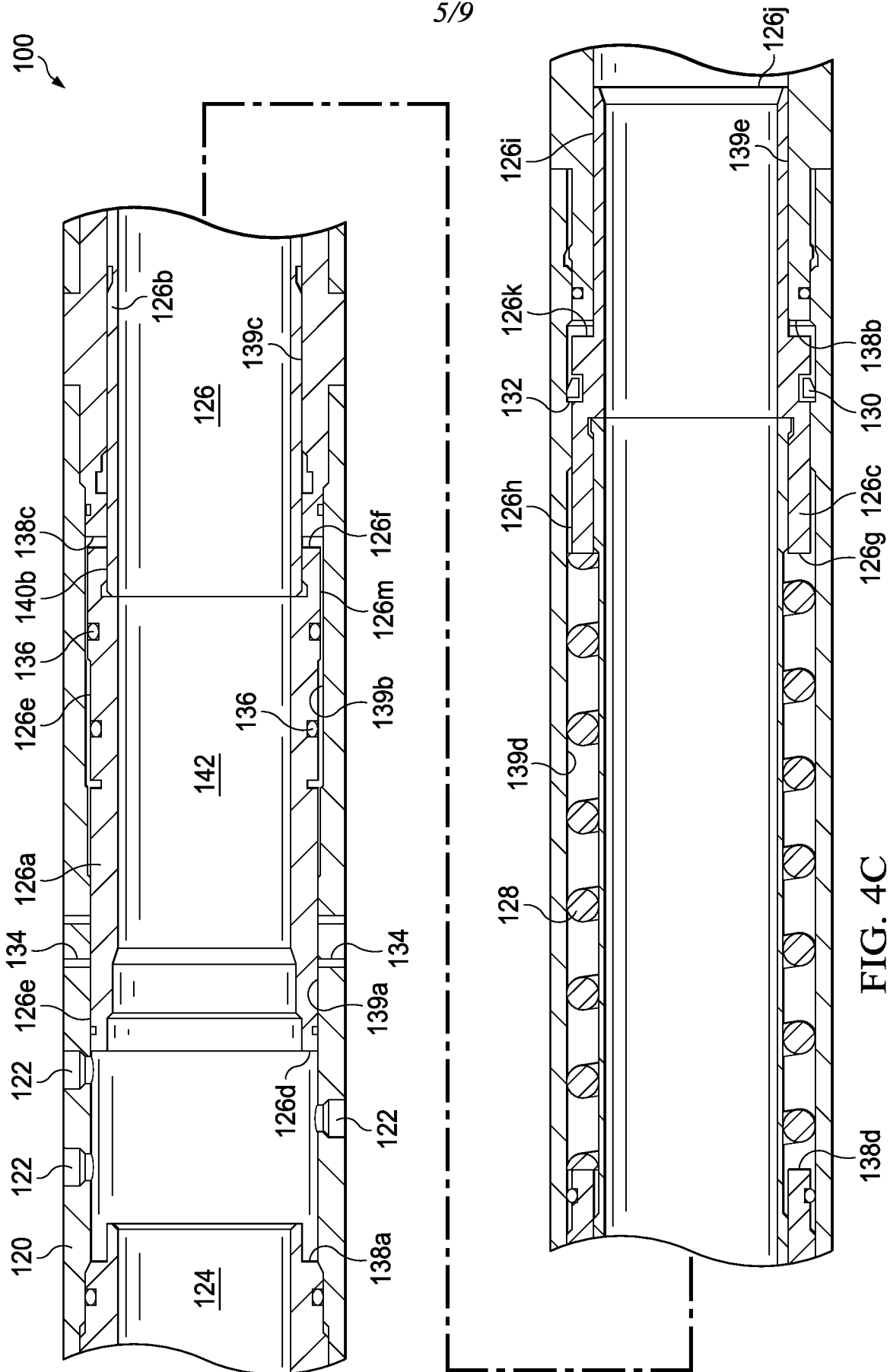

FIG. 4C

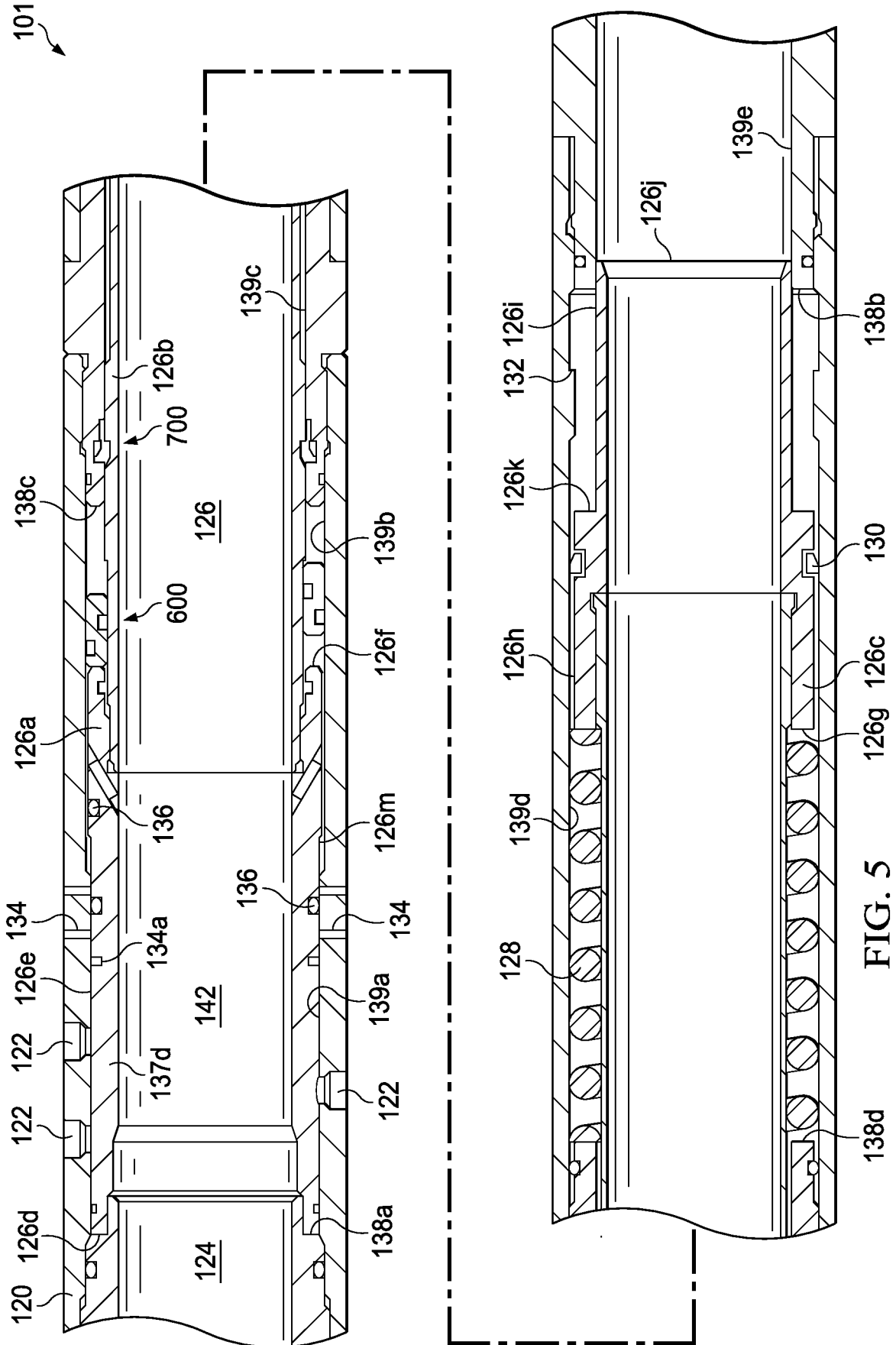

FIG. 5

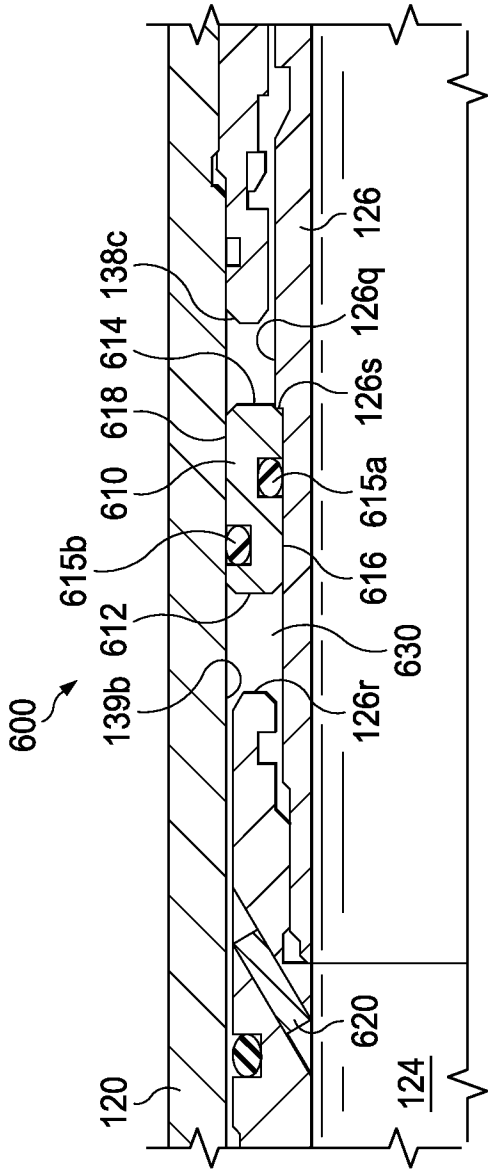

FIG. 6A

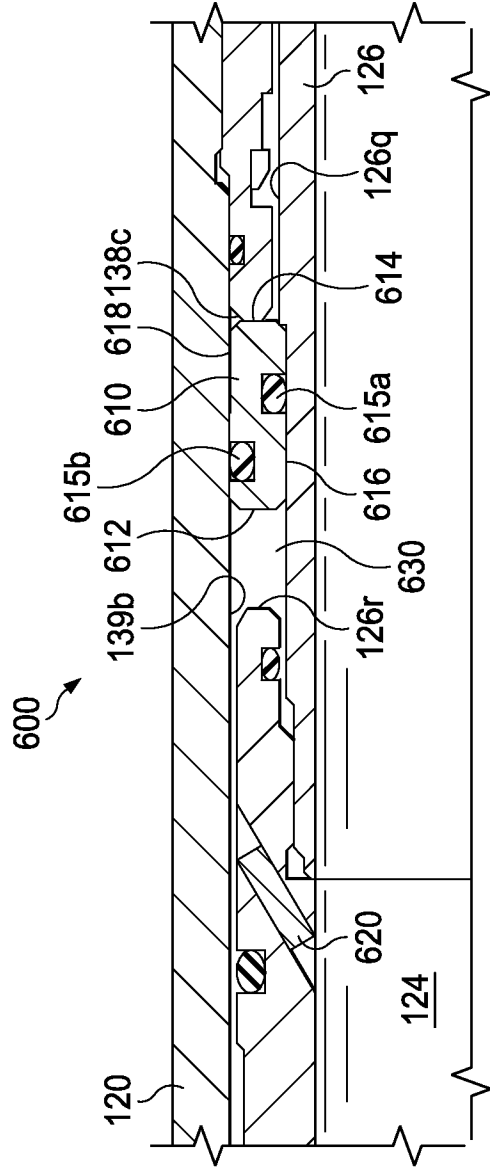

FIG. 6B

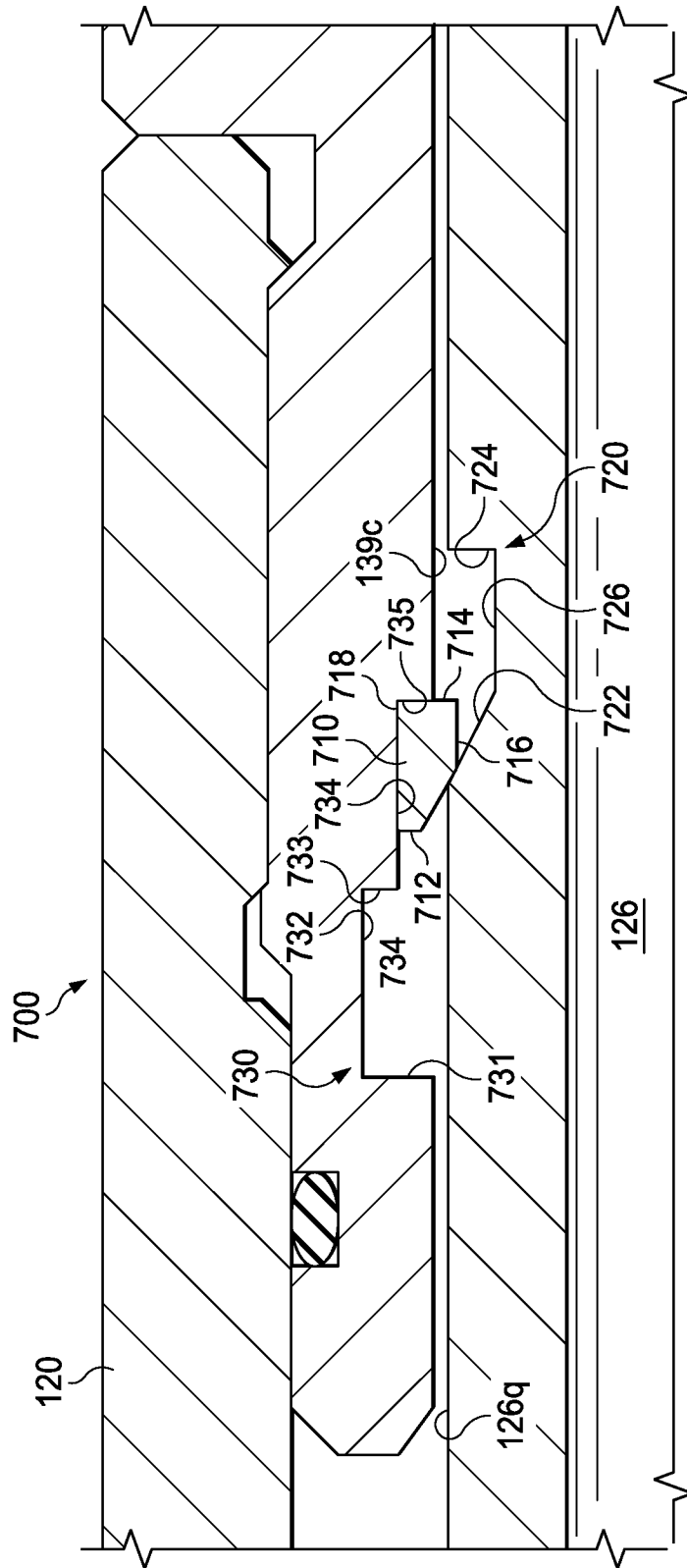

FIG. 7A

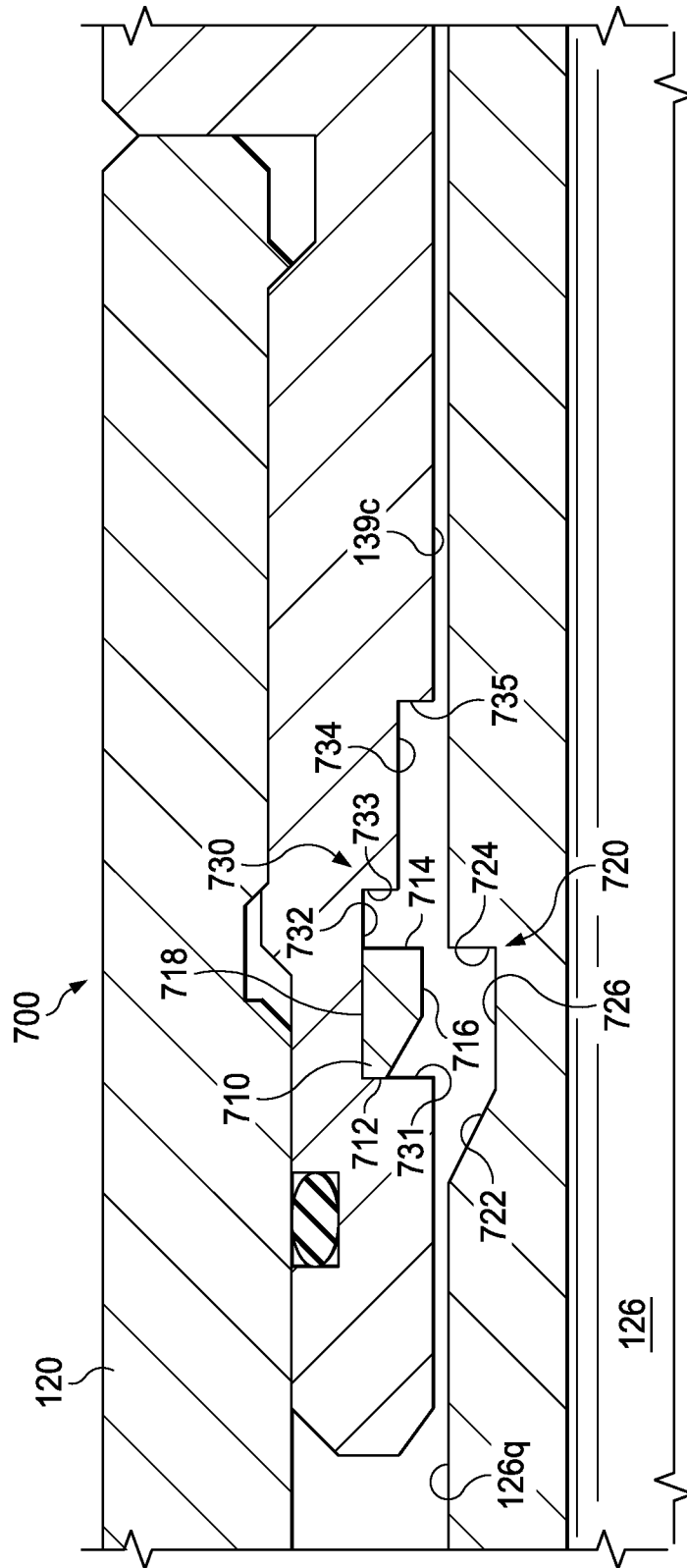

FIG. 7B