



US00D613573S

(12) **United States Design Patent**  
**Latta et al.**

(10) **Patent No.:** **US D613,573 S**

(45) **Date of Patent:** **\*\* Apr. 13, 2010**

(54) **STRAIGHT LINE CUTTER**

(76) Inventors: **Stephen Latta**, 66 Amy Dr., Gap, PA  
(US) 17527; **Thomas Lie-Nielsen**, Box  
9, Warren, ME (US) 04864

(\*\*) Term: **14 Years**

(21) Appl. No.: **29/335,202**

(22) Filed: **Apr. 10, 2009**

(51) **LOC (9) Cl.** ..... **08-03**

(52) **U.S. Cl.** ..... **D8/98**

(58) **Field of Classification Search** ..... D8/98,  
D8/101; 30/162, 293-294, 338

See application file for complete search history.

(56) **References Cited**

**U.S. PATENT DOCUMENTS**

D93,763	S *	11/1934	Dunn	.....	D8/101
D157,105	S *	1/1950	Unsinger	.....	D8/98
3,037,278	A *	6/1962	Genetti, Sr.	.....	30/2
3,448,519	A *	6/1969	Tobias	.....	30/293
3,478,427	A *	11/1969	Tims, Jr.	.....	30/293
4,064,626	A *	12/1977	Meshulam et al.	.....	30/287
D275,447	S *	9/1984	Leyman	.....	D8/98
D281,219	S *	11/1985	Best	.....	D8/98
4,649,647	A *	3/1987	Kaulfuss	.....	30/293
5,203,086	A *	4/1993	Dann	.....	30/293
5,231,764	A *	8/1993	Chang	.....	30/293
D399,402	S *	10/1998	Unruh	.....	D8/98
D422,188	S *	4/2000	Lira-Nunez	.....	D8/98
6,216,577	B1 *	4/2001	Lira-Nunez et al.	.....	83/745
6,430,817	B2 *	8/2002	Hoffman	.....	30/293

6,612,035	B2 *	9/2003	Brown et al.	.....	30/292
6,612,036	B2 *	9/2003	Frazier	.....	30/293
D499,325	S *	12/2004	McLean et al.	.....	D8/98
7,010,860	B2 *	3/2006	Gardner et al.	.....	30/310
D525,095	S *	7/2006	Marcon	.....	D8/51
D594,308	S *	6/2009	Davies et al.	.....	D8/98

**OTHER PUBLICATIONS**

Inlay Tools at Lie-Nielsen Toolworks Inc. Downloaded Nov. 6, 2009 at [http://images.google.com/imgres?imgurl=http://www.lie-nielsen.com/images/StraightCuttersm.jpg&img.\\*](http://images.google.com/imgres?imgurl=http://www.lie-nielsen.com/images/StraightCuttersm.jpg&img.*)

\* cited by examiner

*Primary Examiner*—Philip S Hyder

*Assistant Examiner*—Roselynn Cody

(74) *Attorney, Agent, or Firm*—E. J. Asbury, III, LLC

(57) **CLAIM**

The ornamental design for a straight line cutter, as shown.

**DESCRIPTION**

FIG. 1 is a perspective view of the straight line cutter;

FIG. 2 is a left side view thereof;

FIG. 3 is a front view thereof;

FIG. 4 is a right side view thereof;

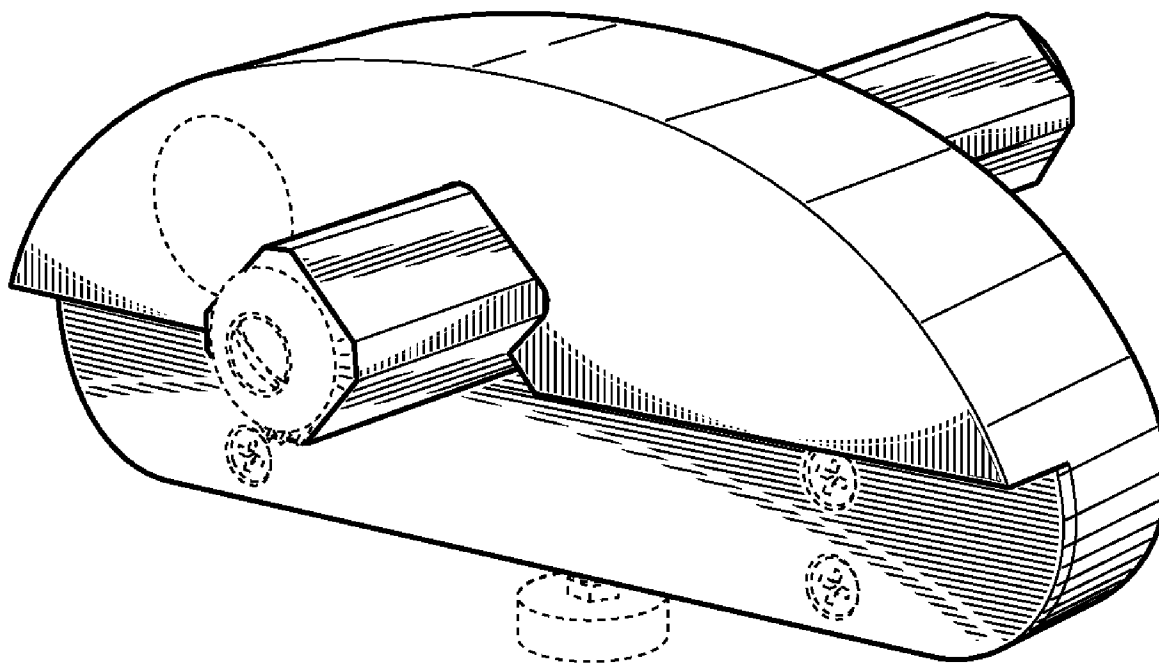
FIG. 5 is a back view thereof;

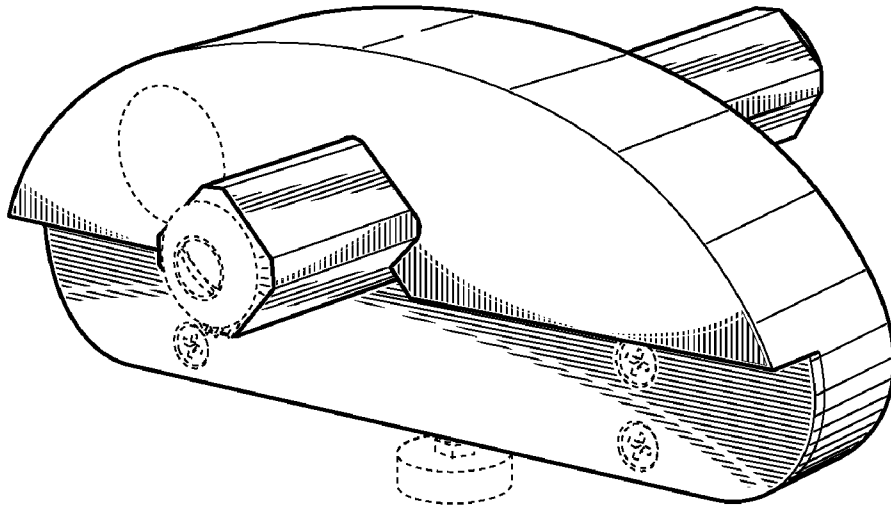
FIG. 6 is a top view thereof; and,

FIG. 7 is a bottom view thereof.

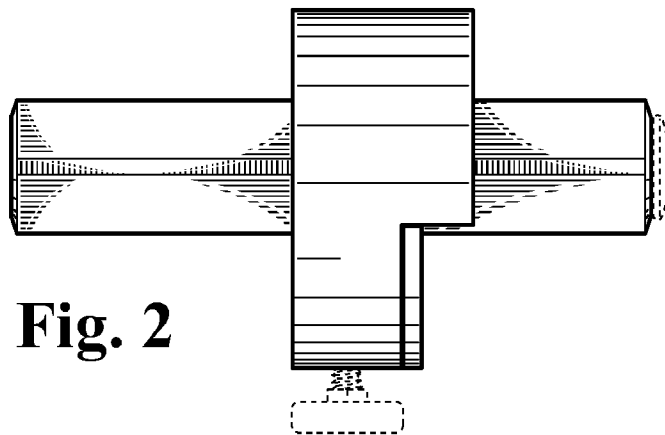
The broken lines shown in FIGS. 1-7 show environmental structure and form no part of the claimed design.

**1 Claim, 3 Drawing Sheets**

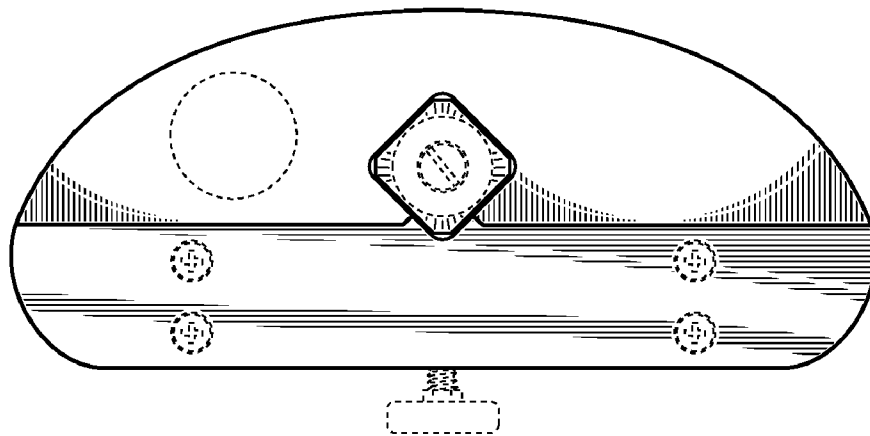




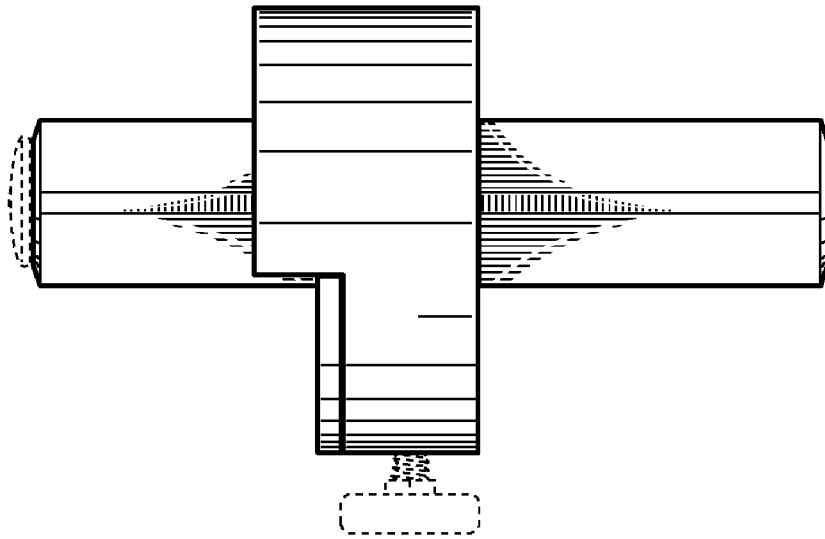
**Fig. 1**



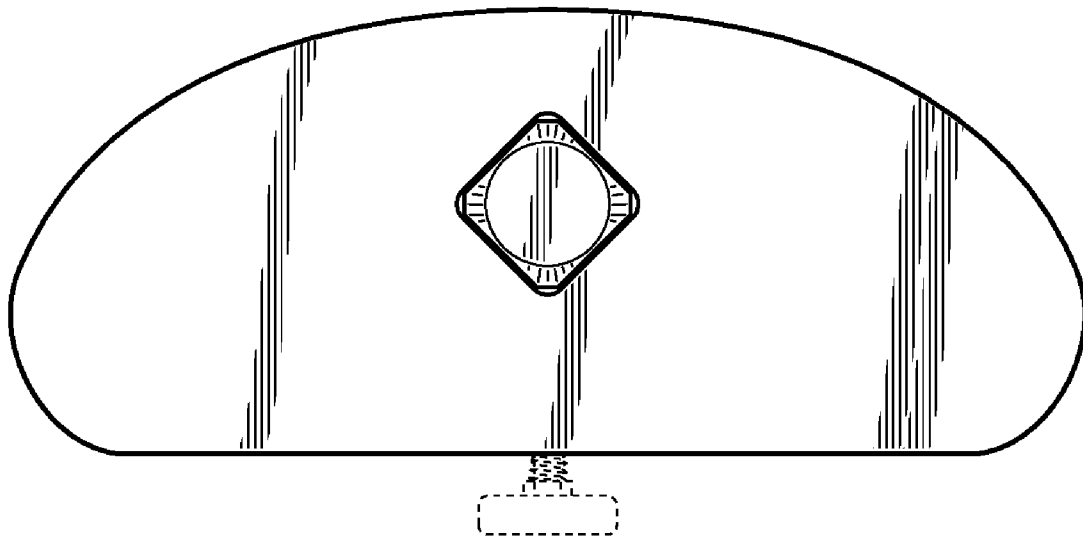
**Fig. 2**



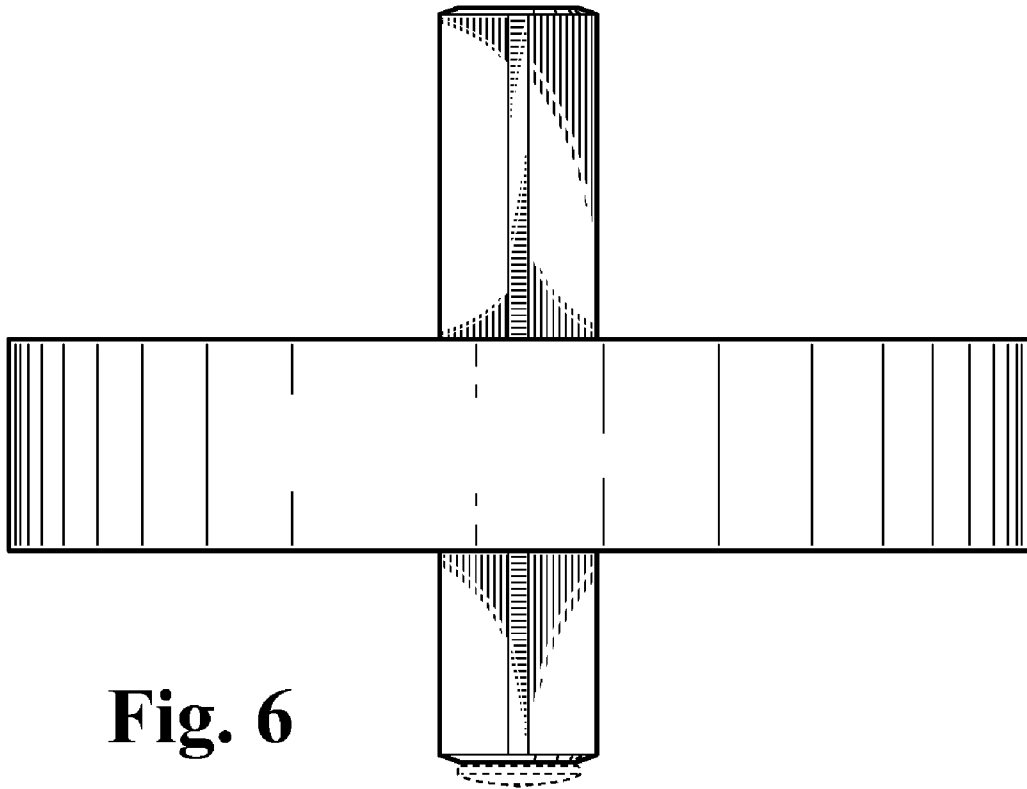
**Fig. 3**



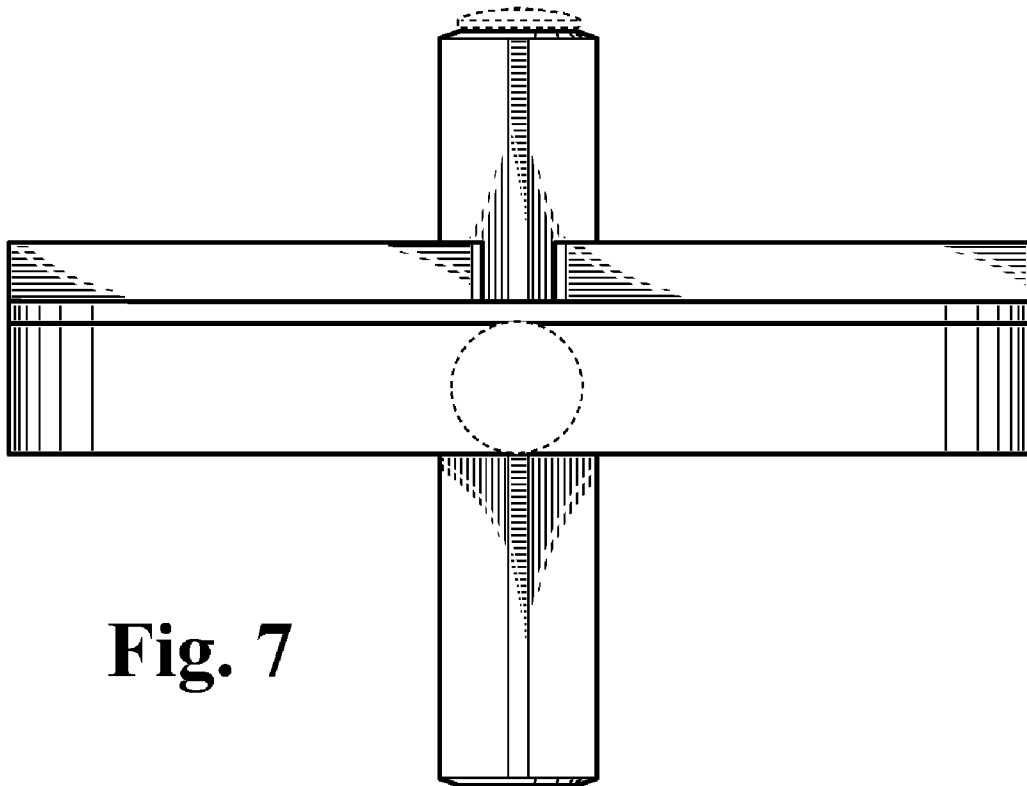
**Fig. 4**



**Fig. 5**



**Fig. 6**



**Fig. 7**