

(19)



(11)

EP 2 008 942 A1

(12)

EUROPEAN PATENT APPLICATION

(43) Date of publication:
31.12.2008 Bulletin 2009/01

(51) Int Cl.:
B65D 41/58 (2006.01) B65D 51/18 (2006.01)
B65D 41/34 (2006.01) B65D 47/12 (2006.01)

(21) Application number: **08155012.1**

(22) Date of filing: **23.04.2008**

(84) Designated Contracting States:
AT BE BG CH CY CZ DE DK EE ES FI FR GB GR HR HU IE IS IT LI LT LU LV MC MT NL NO PL PT RO SE SI SK TR
Designated Extension States:
AL BA MK RS

(71) Applicant: **Guala Closures S.p.A.**
15100 Frazione Spinetta Marengo (AL) (IT)

(72) Inventor: **Capra, Davide**
15040 Lu Monferrato (IT)

(30) Priority: **29.06.2007 IT MI20071310**

(74) Representative: **Fiorani, Giuseppe et al**
Perani Mezzanotte & Partners
Piazza San Babila, 5
20122 Milano (IT)

(54) **An oil pourer**

(57) The present invention relates to a closure (1) for a container (100) having a neck and a mouth, such as an oil bottle, the closure having snap-fitting mutual en-

agement means (8). The closure (1) has portions (10) whose deformability is such that, after the initial opening, it is no longer possible to re-engage the mutual engagement means (8) simply by reclosing the closure (1).

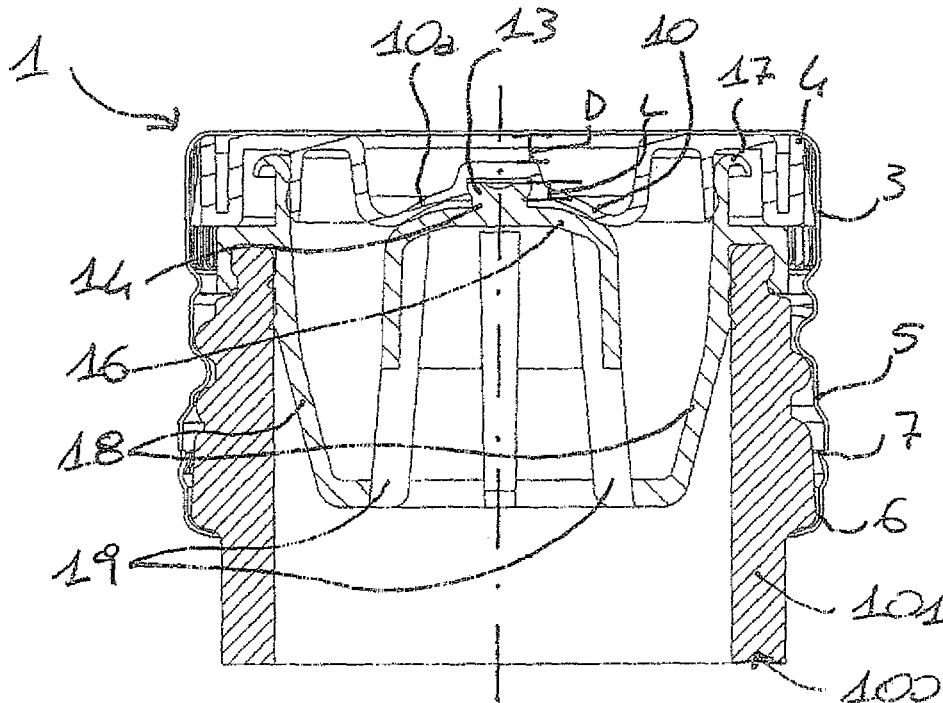

Fig. 1

EP 2 008 942 A1

Description

[0001] The present invention relates to an improved oil pourer.

[0002] A container for edible oil is generally provided with a pouring body to prevent the oil from flowing on the outer walls of the container as a result of its viscosity and its other characteristics, which would make the container particularly troublesome for the user to handle.

[0003] This pouring body is generally made from plastics material and is fixed to the container by fastening systems which act on the inner or on the outer edge of the mouth of the container.

[0004] The pouring body is generally fitted to the container when the outer sealing capsule is fitted.

[0005] The outer capsule comprises a tubular skirt of smooth aluminium which is rolled onto the container to form the securing means which finally fasten the closure to the container.

[0006] Since the minimum inner diameter of the metal capsule is larger than the maximum outer diameter of the pouring body, the pouring body must be fixed to the capsule by suitable fixing means, in such a way that the two elements remain fixed together while the closure is moved, from the time of its production until it is fitted on to the container,

[0007] Utility model IT207976U discloses an oil pourer in which the pouring body (7, in Figure 1) is fixed to inner stopper 13 of metal cap 8 by snap-fitting of the lip of the pouring body.

[0008] However, this closure has the disadvantage of fixing the two parts together whenever the container is closed, thus subjecting the pouring body to repeated stresses which may damage the pouring lip and cause it to lose its functionality.

[0009] Since the fixing takes place by the snap-fitting of the pouring lip, the oil remaining on the lip tends to adhere to it.

[0010] Furthermore, the two parts of the snap fitting have to be disengaged on each opening, causing a temporary increase in the resistance to opening perceived by the user and the production of an audible click which may be disagreeable to users.

[0011] In view of the prior art described above, the object of the present invention is to provide an improved oil pourer which does not have the disadvantages of the prior art.

[0012] Another object of the present invention is to provide a closure in which there is no perceptible resistance during the operations of opening and closing the container after the initial opening.

[0013] Another object of the present invention is to promote a regular outflow of liquid from the container without interruption and to reduce what is known as the "surge", in other words the phenomenon by which, when liquid is drawn from a partially empty container, the gravitational inertia of the liquid generates an excess force which, in the case of oil pourers, produces an undesirable spray

which may throw drops of liquid far from the desired point.

[0014] According to the present invention, this object is achieved by means of a closure according to Claim 1, and by a method for assembling such a closure according to Claim 10.

[0015] The features and advantages of the present invention will be made clear by the following detailed description of a practical embodiment, provided by way of non-limiting example, with reference to the appended drawings, in which:

- Figure 1 shows a longitudinal cross-section through a closure comprising an oil pourer according to a preferred embodiment of the present invention, before the initial opening;
- Figure 2 shows a longitudinal cross-section through the closure of Figure 1 which has been reclosed after the initial opening;
- Figure 3 shows a perspective view of the pouring body of the closure of Figure 1;
- Figure 4 shows a view from below of the pouring body of Figure 3.

[0016] Closure 1 can be fixed onto the neck 101 of a container 100, such as neck 101 of a bottle, and comprises a pouring body 2, an outer capsule 3 which fixes closure 1 to container 100, and an inner stopper 4, which is fixed to outer capsule 3 and which, when fitted to container 100, can prevent the outflow of oil from container 100. Outer capsule 3 is generally composed of a stopper 5 and a skirt 6, joined together along a breakable line 7. In an alternative embodiment, inner stopper 4 and stopper 5 are formed in one piece.

[0017] Inner stopper 4 and pouring body 2 comprise snap-fitting mutual engagement means 8, which fix them together before closure 1 is fitted on container 100.

[0018] According to the invention, inner stopper 4 and pouring body 2 are shaped so that the force required for engagement of mutual engagement means 8 is greater than the force which can be exerted on them by the reclosing of closure 1.

[0019] In other words, mutual engagement means 8 are engaged with each other before the initial opening, but after they have been separated by the initial opening it is no longer possible to engage them with each other by the normal operations of opening and closing closure 1 according to the present invention.

[0020] During the reclosing operation, inner stopper 4 is longitudinally moved towards pouring body 2 and therefore mutual engagement means 8 are brought closer together.

[0021] The maximum force that mutual engagement means 8 can exchange with each other depends on the strength of the material of inner stopper 4 and of pouring body 2; this strength is chosen in such a way that the maximum force that can be exerted is lower than the minimum force required for the engagement of mutual engagement means 8.

[0022] Advantageously, mutual engagement means 8 engage with each other along the longitudinal direction X-X, defined by longitudinal axis X-X of container 100 and of neck 101 thereof.

[0023] When stopper 5 and inner stopper 4 are separated from the rest of closure 1 (in the course of production, for example, or after closure 1 has been opened), inner stopper 4 and stopper 5 can be separated by a distance D other than zero in the longitudinal direction X-X, in the proximity of the position of said mutual engagement means 8; D can be substantially equal to or greater than the length L of the longitudinal portion of the mutual engagement means 8 which is in engagement before the initial opening.

[0024] This ensures that the deformability of inner stopper 4, which prevents engagement of mutual engagement means 8, is not limited by the presence of stopper 5, which must be more rigid than inner stopper 4.

[0025] In this preferred embodiment, inner stopper 4 comprises a portion 10 whose deformability in longitudinal direction X-X is substantially greater than the deformability of the other parts; advantageously, such a highly deformable portion 10 is shaped in the form of a bellows and/or a bell. Thus it is possible to form stopper 5 and inner stopper 4 so that they are separate but fixed together.

[0026] In an alternative preferred embodiment (not shown in the drawings), the highly deformable portion 10 is formed in pouring body 2. This second embodiment makes it possible, for example, to form inner stopper 4 in one piece with stopper 5.

The higher deformability can also be achieved, for example, by using portions of wall 10a and 10b of inner stopper 4 and/or of pouring body 2 which have a reduced thickness; the high deformability is substantially achieved by suitable shaping and reduction of the thickness of inner stopper 4 and/or of pouring body 2 respectively.

[0027] With reference to the embodiment shown in the drawing, mutual engagement means 8 comprise a female element 11, formed on inner stopper 4, and a male element 12, formed on pouring body 2. However, the opposite configuration, which is equivalent to the above, can also be used.

[0028] The male element 12 comprises a stem 13 and a flared portion 14 which becomes wider in the longitudinal direction X-X towards said inner stopper 4, while female element 11 can comprise a cavity 15 which becomes narrower in the longitudinal direction X-X towards pouring body 2. Advantageously, the volume of cavity 15 is such that it can contain flared portion 14; in other words, it is greater than the volume of this portion.

[0029] As shown in the drawings, mutual engagement means 8 can be positioned substantially in the centre of the closure 1 and/or there can be a single stem 13 coaxial with the longitudinal axis X-X

[0030] Pouring body 2 can also comprise a central portion 16, which is advantageously dome-shaped, and

which, when closure 1 is fitted on container 100, is at least partially inserted into neck 101 of container 100 and preferably lies completely inside pouring lip 17 of pouring body 2 (with respect to the longitudinal direction),

[0031] In the embodiment shown in the drawings, this central portion 16 is connected to lateral portion 18 of pouring body 2 by ribs 19 which define four corresponding radial apertures 20 for the outflow of liquid from the interior of container 100

[0032] Advantageously, the outer diameter of central portion 16 and the inner diameter of lateral portion 18 are substantially equal, and radial apertures 20 are formed along a substantially cylindrical or slightly conical surface.

[0033] In the embodiment shown in the drawings, there are four ribs 19; clearly, the number of ribs 19 can be different, for example three, five, six or more,

[0034] As shown in Figures 1 and 2, connecting ribs 19 extend radially for a distance which may be as much as twice the thickness of central portion 16, so as to form blades which provide better shaping of the flow of liquid out of container 100.

[0035] This configuration, which is particularly advantageous, also makes it possible to provide a particularly regular outflow of liquid in the case of oil, acting in a highly effective way to counteract the "surge" phenomenon described above,

[0036] As shown in Figure 2, the outer diameter of central portion 16 and the inner diameter of lateral portion 18 are substantially equal, and radial apertures 20 are formed along a substantially cylindrical or slightly conical surface.

[0037] Pouring body 2 and/or inner stopper 4 can be made from polymer material, for example PE, by injection moulding for example; on the other hand, stopper 5 and skirt 6 can be made from drawn aluminium.

[0038] Clearly, if inner stopper 4 and stopper 5 are formed in one piece, they can be made from the same materials, and by the same methods as those described previously with reference to inner stopper 4.

[0039] Since the effect of closure 1 according to the present embodiment is to prevent a simple connection of inner stopper 4 to pouring body 2, it must be assembled by exerting a force between the mutual engagement means 8 in the longitudinal direction X-X which must be obtained by using a support which is separate from closure 1.

[0040] The support for pouring body 2 and/or for inner stopper 4 enables mutual engagement means 8 to be fully engaged by snap-fitting, after which the support is removed.

[0041] When closure 1 has been assembled, it can be fitted on mouth 102 of a container 100 having a neck 101 and a mouth 102, and skirt 6 of closure 1 can then be rolled on so as to securely fix closure 1 to container 100. When closure 1 is reclosed, the deformability of inner stopper 4 and/or of pouring body 2 can prevent the transmission between them of a sufficient force for mutual

engagement means 8 to mutually engage anew, even when stopper 5 is fully screwed onto container 100.

[0042] Clearly, a person skilled in the art can make numerous modifications and variations to the configurations described above, in order to meet contingent and specific requirements, all such modifications and variations being contained within the scope of protection of the invention as defined in the following claims.

Claims

1. A closure (1) suitable for being fixed to the neck (101) of a container (100) having a neck (101), such as a bottle, said closure (1) comprising:

- a pouring body (2),
- an outer capsule (3), for fixing the closure (1) to said container (100), comprising a stopper (5) connected to a skirt (6) by a breakable line (7);
- an inner stopper (4), securely fixed to or made in one piece with said stopper (5), and capable of preventing the outflow of liquid from said container (100) when fitted on said container (100);
- said inner stopper (4) and said pouring body (2) comprising snap-fitting mutual engagement means (8) which fix them to each other before said closure (1) is fitted on said container (100),

characterized in that

said inner stopper (4) and said pouring body (2) are shaped in such a way that the force required for the engagement of said mutual engagement means (8) is greater than the force which can be exerted on them by reclosing said closure (1).

2. A closure (1) according to the preceding claim, in which, when the stopper (5) and the inner stopper (4) are at rest, in other words when they are separated from the rest of the closure (1), said inner stopper (4) and said stopper (5) are separated from each other, in the proximity of the position of said mutual engagement means (8), by a distance D, which is substantially equal to or greater than the length of the engagement portion by which the mutual engagement means (8) are in engagement before the initial opening.

3. A closure (1) according to either one of the preceding claims, in which said inner stopper (4) and/or said pouring body (2) comprise a portion (10) whose deformability in the longitudinal direction (X-X) is substantially greater than the deformability of the other parts.

4. A closure (1) according to the preceding claim, in which said highly deformable portion (10) is shaped in the form of a bellows and/or a bell.

5. A closure (1) according to any one of the preceding claims, in which said mutual engagement means (8) comprise a female element (11), formed on the inner stopper (4), and a male element (12), formed on the pouring body (2).

6. A closure (1) according to the preceding claim, in which said male element (12) comprises a stem (13) and a flared portion (14) which becomes wider in the longitudinal direction (X-X) towards said inner stopper (4).

7. A closure (1) according to any one of the preceding claims, in which said mutual engagement means (8) are positioned substantially in the centre of said closure (1)

8. A closure (1) according to any one of the preceding claims, in which said pouring body (2) and/or said stopper (4) are made from polymer material.

9. A closure (1) according to any one of the preceding claims, in which said outer capsule (3) is made from drawn aluminium.

10. A method of assembling a closure (1) according to any one of the preceding claims, comprising the steps of:

- a) providing a pouring body (2) and an inner stopper (4) according to any one of the preceding claims;
- b) providing a support in the longitudinal direction (X-X) for the pouring body (2) and/or for the inner stopper (4);
- c) supporting the pouring body (2) and/or the inner stopper (4) in the longitudinal direction (X-X) by means of the support;
- d) bringing the pouring body (2) and/or the inner stopper (4) towards each other in the longitudinal direction (X-X) until the snap-fitting mutual engagement means (8) are fully engaged;
- e) removing the support.

11. A method according to the preceding claim, additionally comprising the step of:

- e) fitting the closure (1) according to any one of Claims 1 to 6 to the mouth of a container (100) provided with a neck (101) and a mouth, after steps a), b), c) and d).

12. A method according to either claim 10 or claim 11, additionally comprising the step of:

- g) rolling the skirt (6) of said closure (1) so as to fix it securely to said container (100).

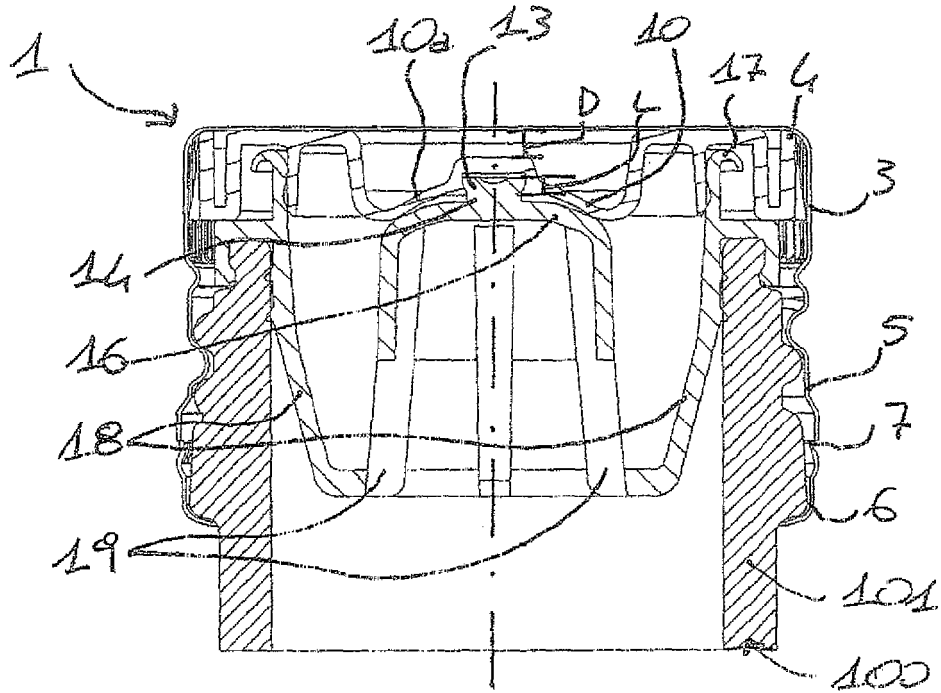

Fig. 1

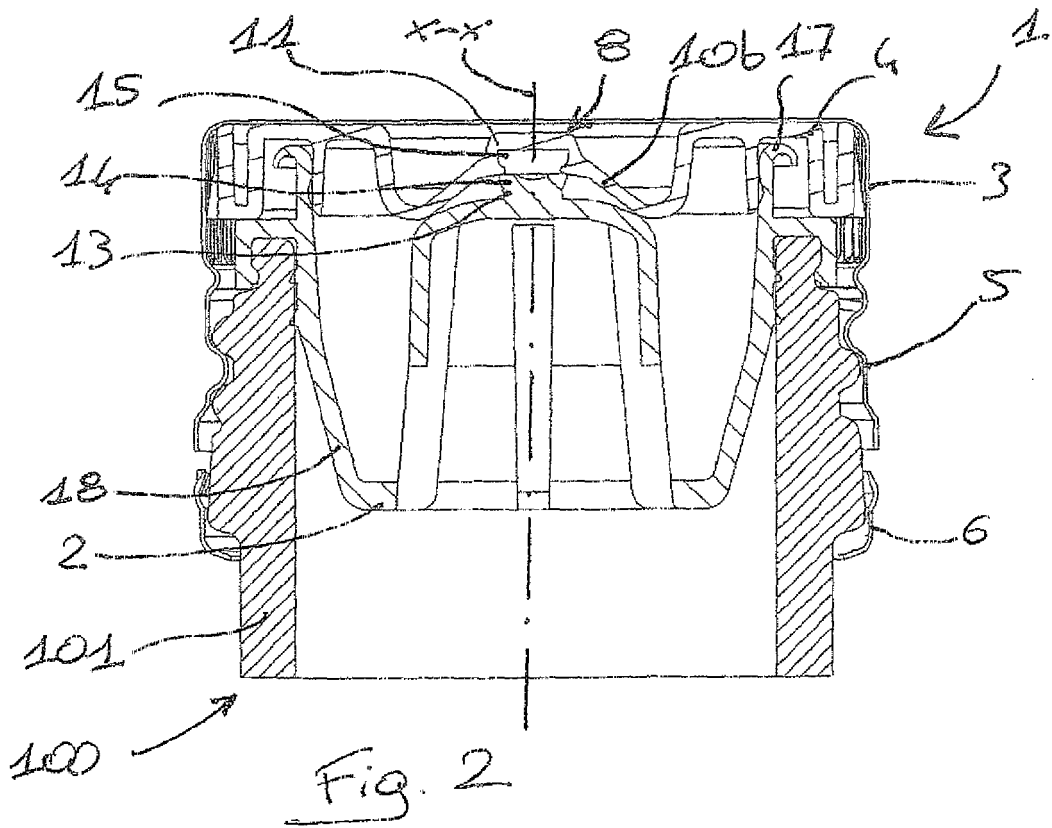

Fig. 2

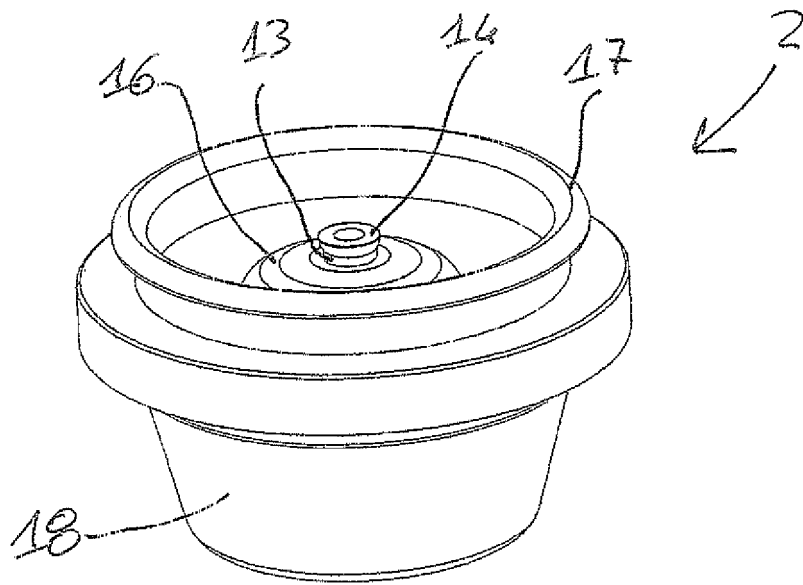

Fig. 3

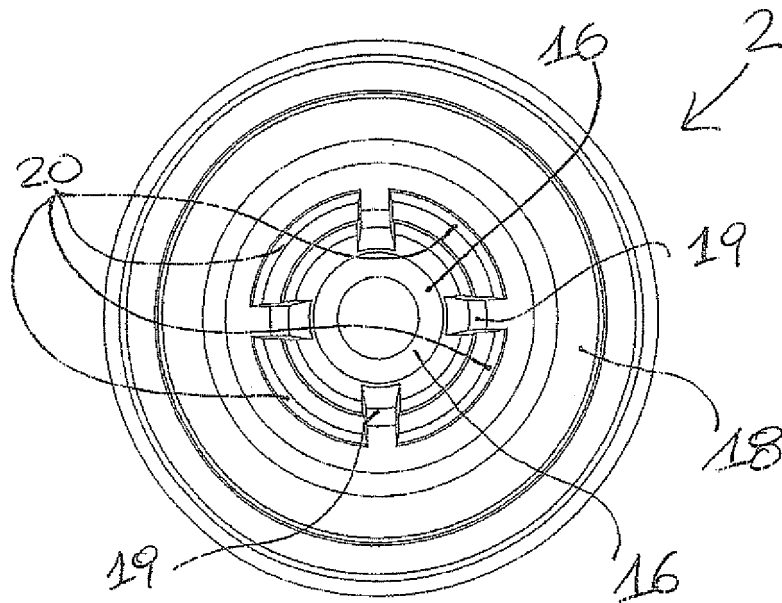

Fig. 4



EUROPEAN SEARCH REPORT

Application Number
EP 08 15 5012

DOCUMENTS CONSIDERED TO BE RELEVANT			
Category	Citation of document with indication, where appropriate, of relevant passages	Relevant to claim	CLASSIFICATION OF THE APPLICATION (IPC)
X	GB 2 296 911 A (GUALA UK LTD [GB]) 17 July 1996 (1996-07-17)	10-12	INV. B65D41/58
A	* page 2 - page 3; figures 1-3 * -----	1-9	B65D51/18
A	FR 2 271 134 A (BOUCHAGE MECANIQUE [FR]) 12 December 1975 (1975-12-12)	1-12	ADD. B65D41/34 B65D47/12
A	* page 2 - page 3; figures 1,3 * -----		
A	GB 2 280 895 A (VICTORY MALCOLM GORDON [GB]) 15 February 1995 (1995-02-15)	1-12	
	* page 12 - page 27; figures 1-25 * -----		
			TECHNICAL FIELDS SEARCHED (IPC)
			B65D
The present search report has been drawn up for all claims			
Place of search Munich		Date of completion of the search 7 October 2008	Examiner Fitterer, Johann
CATEGORY OF CITED DOCUMENTS X : particularly relevant if taken alone Y : particularly relevant if combined with another document of the same category A : technological background O : non-written disclosure P : intermediate document T : theory or principle underlying the invention E : earlier patent document, but published on, or after the filing date D : document cited in the application L : document cited for other reasons & : member of the same patent family, corresponding document			

2
EPO FORM 1503 03/82 (P04C01)

**ANNEX TO THE EUROPEAN SEARCH REPORT
ON EUROPEAN PATENT APPLICATION NO.**

EP 08 15 5012

This annex lists the patent family members relating to the patent documents cited in the above-mentioned European search report. The members are as contained in the European Patent Office EDP file on
The European Patent Office is in no way liable for these particulars which are merely given for the purpose of information.

07-10-2008

Patent document cited in search report	Publication date	Patent family member(s)	Publication date
GB 2296911	A	17-07-1996	NONE
FR 2271134	A	12-12-1975	NONE
GB 2280895	A	15-02-1995	NONE

EPO FORM P0459

For more details about this annex : see Official Journal of the European Patent Office, No. 12/82

REFERENCES CITED IN THE DESCRIPTION

This list of references cited by the applicant is for the reader's convenience only. It does not form part of the European patent document. Even though great care has been taken in compiling the references, errors or omissions cannot be excluded and the EPO disclaims all liability in this regard.

Patent documents cited in the description

- IT 207976 U [0007]