

Tinker and Sprague,  
Mower.

No 17945

Patented Aug. 4. 1857.

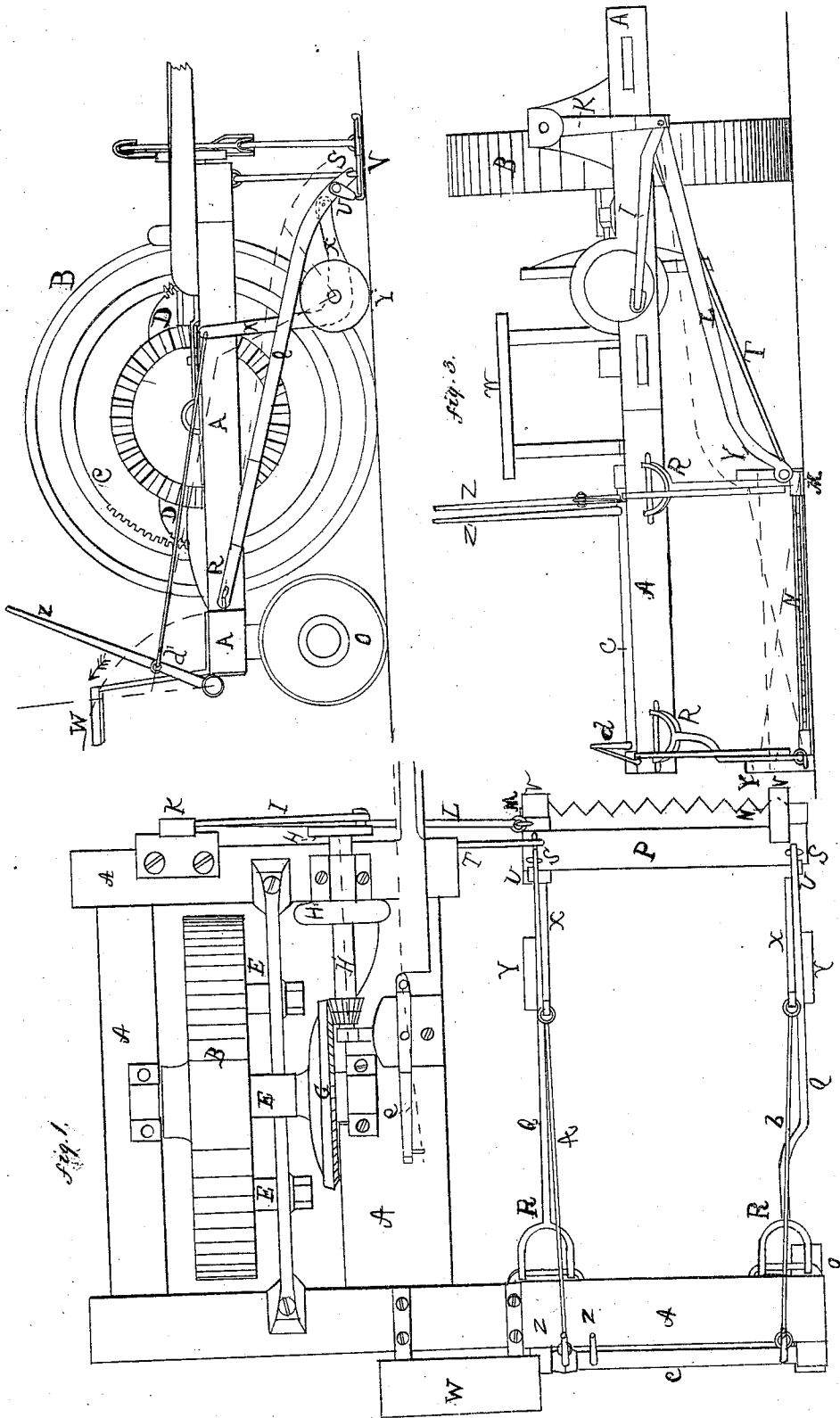

# UNITED STATES PATENT OFFICE.

CHARLES TINKER AND J. A. SPRAGUE, OF MANTUA, OHIO.

## IMPROVEMENT IN HARVESTERS.

Specification forming part of Letters Patent No. 17,945, dated August 4, 1857.

*To all whom it may concern:*

Be it known that we, C. TINKER and J. A. SPRAGUE, of Mantua, in the county of Portage and State of Ohio, have invented new and useful Improvements in the Construction of Grass and Grain Harvesters; and we do hereby declare that the following is a full and exact description thereof, reference being had to the accompanying drawings, in which—

Figure 1 is a top view of the machine. Fig. 2 is a side elevation, and Fig. 3 a front elevation.

Like letters refer to like parts in the several views.

A represents the frame of the machine, and B the driving or ground wheel. This has an interior rim, C, Fig. 2, furnished with cogs upon its inner surface. These cogs drive two pinions D D, which are supported on journals E E, that pass through the bar F, which is bent downward so as to let the shaft of the main wheel pass above it, as seen at E', Fig. 1. The shaft of the main wheel forms the journal or bearing of the bevel-wheel G, which has a hollow shaft through which the main shaft passes. A small leading-wheel, that cannot be seen in any of the views, gears into both the wheels D D. Standing, as it does, between them, and being concentric with the main wheel, it receives its power equally from both the wheels D D, this power and motion being communicated to the bevel-wheel G, which is situated upon the same shaft, and which is also concentric with the main wheel. This bevel-wheel G drives the crank-shaft H, upon which is the balance-wheel H' and the crank-wheel H'', Fig. 3. The connecting-rod I extends from the crank to the vibrating suspension-rod K. By this means another connecting-rod, L, is put in motion, and this, by its connection with the cutter-bar M N, gives motion to that part, as seen in Figs. 1 and 3. The end of the frame that carries the cutter-bar and its appendages is supported by a ground-wheel, O, Figs. 1 and 2. The cutter-bar M N and the finger-bar P are supported upon or by long arms Q Q. These arms divide before reaching the frame-timber A, as seen at R R, and are secured to that piece by a long staple or its equivalent, that passes through holes in the branching ends, and then, turning at right angles, enters the frame A.

The holes through which the staple passes

are oblong on the outer end of each arm, as seen at R', Fig. 2, to allow of a little vibration, necessary to the free action of the several parts, as hereinafter described. The finger-bar P is attached at each end to one of the arms Q by a link or universal joint, as seen at S S, Figs. 1 and 2, thus allowing the cutter and finger bar to rise and fall with the inequalities of the ground; or one end can rise while the other falls, or vice versa, and thus the cutter-bar can adapt itself to elevations and depressions in every direction.

For the purpose of guarding against a side-wise strain we attach a long rod, T, by a link or joint, to the inner end of the finger-bar P, as seen at T'. The opposite end of this rod is attached to the under side of the forward part of the frame A by a link-joint at a point exactly coinciding in its position with the union of the two connecting-rods I and L—that is, the rod T has just the same length as the connecting-rod L, which drives the cutter-bar. By this arrangement the cutter-bar and its appendages are free to move in any direction except sidewise.

In order to prevent the cutter and finger bar from tipping forward and thus digging into the ground, we apply stops U U to the under side of the forward part of the arms Q Q, which strike upon the heel of the shoe V. This allows the cutter-bar to vibrate upward from a horizontal position, but will not allow the forward edge to drop below the horizontal plane.

For the purpose of placing the cutter-bar entirely under the control of the driver, as he sits upon his seat W, so that he may raise it from the ground in order to avoid coming in contact with a stone or other obstruction, either in the middle or at either end of the cutter-bar, we attach bent levers X X, by the shorter arm, to the forward end of the arms Q Q. The fulcrum of this bent lever consists of the wheel Y, the journal of which passes through the angle of the lever and the face of the wheel resting upon the ground, thus forming the fulcrum. The long arms of the levers X extend upward, each being united to or coupled with the hand-levers Z and Z' (shown in Fig. 3 by the side of the seat W, and at Z and Z' in Figs. 1 and 3) by means of connecting-rods a and b, Fig. 1.

The rod a connects with the lever Z, and by drawing back the upper end of this lever in the direction of the arrow to a vertical posi-

tion (see red line in Fig. 2) the inner or left-hand end of the cutter-bar can be elevated to avoid any obstacle that may be seen ahead by the driver. The lever *Z'* being attached to a rock-shaft, *c*, that extends along the frame-work *A* from the seat *W* toward the right, and having an arm, *d*, extending upward about a foot—a distance corresponding to the point of attachment of the rod *a* to the lever *Z*, as seen at *d'*, Fig. 2—the lever *Z'* being drawn backward, in the same manner as has been described in reference to the lever *Z*, the outer end of the cutter-bar can in like manner be raised from the ground at the pleasure of the driver, in order to avoid any obstruction, or the whole cutter-bar and its appendages can be raised so as to entirely clear the ground. In this movement of one, or either, or both of the levers *Z* and *Z'* the weight of the cutter-bar and its appendages is transferred, in whole or in part, as one or both the levers are drawn back from the shoes *V V* to the wheels *Y Y*, which form the fulcrums of the bent levers *X X*.

In moving the machine from place to place, or from one field to another, both the levers *Z* and *Z'* are drawn backward as described, and secured. At the same time the bevel-wheel upon the crank-shaft *H* is thrown out of gear by the

sliding lever *e*, and the whole machine is drawn over the ground upon the four wheels *B O Y Y*, as described. The bevel-wheel upon the shaft *H* being now slipped into gear and the levers *Z* and *Z'* released, the machine is ready for operation.

In backing the machine out of the grass or grain, in turning a corner, or in passing over mown grass, the advantages of this arrangement become most apparent.

What we claim as our improvement, and desire to secure by Letters Patent, is—

The vibrating arm *K*, parallel rod *I*, and connecting-rod *T*, in combination with the bent levers *X X*, fulcrum-wheels *Y Y*, levers *Z Z'*, and stops *U U*, when the same are arranged to operate in relation to each other and used in connection with a self-adjusting cutter and finger bar substantially in the manner and for the purpose set forth.

CHARLES TINKER.  
J. A. SPRAGUE.

Witnesses:

JOHN T. ESTY,  
BILLINGS P. FINCH,  
J. E. RIDDLE,  
ANDREW J. SQUIRE.