

J. D. Elliot.
Cloth Folding and Measuring Mach.

N^o 13,543.

Patented Sep. 11. 1855

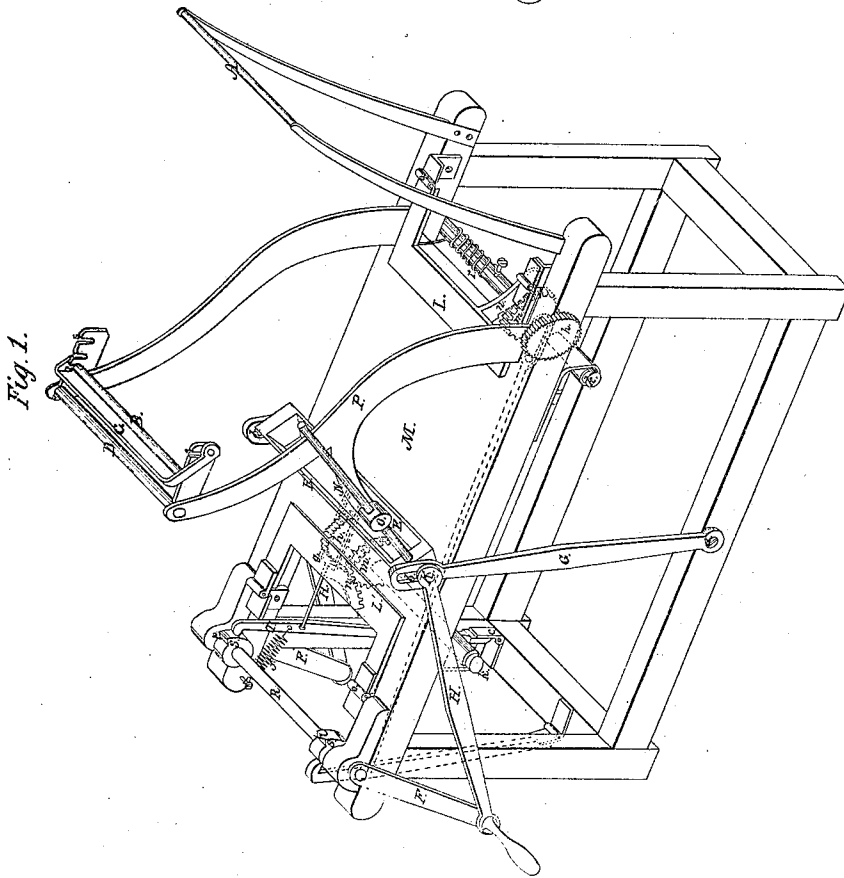
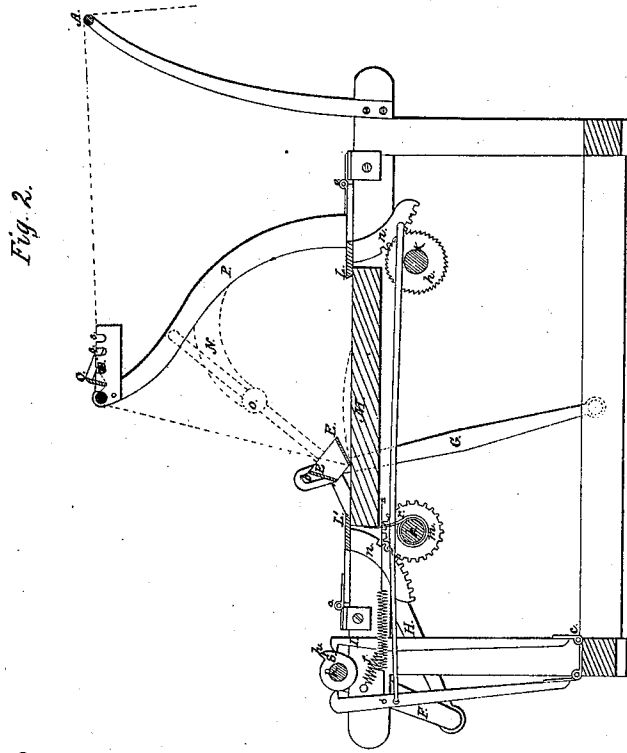

UNITED STATES PATENT OFFICE.

JOS. D. ELLIOT, OF LEICESTER, MASSACHUSETTS.

MACHINERY FOR FOLDING AND MEASURING CLOTH.

Specification of Letters Patent No. 13,543, dated September 11, 1855.

To all whom it may concern:

Be it known that I, JOSEPH D. ELLIOT, of Leicester, in the county of Worcester and State of Massachusetts, have invented certain new and useful Improvements in Machines for Folding and Measuring Cloth; and I do hereby declare the following to be a full, clear, and exact description of the same, reference being had to the accompanying drawings, making a part thereof, in which—

Figure 1, represents a perspective view of the cloth folder; Fig. 2, a longitudinal vertical section.

The nature of this invention relates to an arrangement of machinery, for folding and measuring cloth the particulars of which will be seen from the following description.

The cloth which is indicated by a red dotted line in Fig. 2, passes first over a roller A, thence to a roller B, thence underneath a bar C, on to roller D, down to the blades E, E'. The shape of these blades is more particularly shown in the perspective view in Fig. 1, but also seen in the cross section in Fig. 2. They are set in motion by means of a crank F, which imparts to the upper end of the arm G, a reciprocating motion by means of the pitman H, the arm G turning on a pin *a*, as its fulcrum. The crank, pitmen and arms G, are attached to each side of the frame, and are connected with the blades by means of pins K, which are fixed to the ends of the blades, but which can play in the slots *b*, of the arms G, for the purpose hereafter described.

The cloth is supposed to be held on one end by the pressure of the jaw L to the bed plate M; it passes around the edge of the blade E up to the roller D; the blade E carries it to the jaw L', which by a device hereafter described, is lifted at the same moment when the blade E, meets it and then is pressed down again so as to take hold of the cloth.

It is obvious that when the blades return to L, the blade E', has to assume a similar position respectively to L, as E holds now to L'. To accomplish this the blades must turn on the pin K, as fulcrum when passing between L and L'; this is done by means of a rod N, which being attached to one end of the blades as shown in Fig. 1, passes through a movable nut or swivel O, in such manner that it can slide in it. The swivel

O, is cylindrically shaped and can turn freely on a pivot in its axis which turns in the frame P.

The blades in passing from L to L' are guided by the arm G, and thus the swivel O, can be considered as a second fulcrum through which the rod N, can slide to allow the blades the motion of the pin K. When the cloth increases on the bed plate M, the blades can rise with it by means of the slot *b*, in which the pin K, slides as above described; this is very essential, as the machine could not work if the point K was a fixed one.

The following arrangement can serve to lift the jaws L, L'; the same object can be accomplished by other equivalents. On the driving shaft R, are the cams S and S'. The cam S' acts on a pawl T, which can turn at its lower end on hinges *c*; and is pressed to the cams by means of a spiral spring *f*; the dog *g* is attached to the pawl T, by means of a rod and operates on a ratch wheel *h*, which is keyed on to the shaft *k*. A cog wheel *m*, is also keyed to the same shaft which acts on the toothed sector *n* attached to the jaw L' which is thus lifted up by each motion of the wheel, the jaw turning on its hinges *o*. As soon as the edge of the blade E, brings the cloth to the jaw L', the point *p* of the cam S, operates on the pawl T, and by the arrangement just described it lifts the jaw L'; it is necessary that the jaw L' be pressed down again directly so as to hold the cloth. This is done by means of a spiral spring *r* which is wound up and fixed by means of a screw on the shaft *k*, and which with its loose end bears on the bed plate M thus forcing the shaft *k* to revolve in a direction opposite to the one produced by the pawl *g* and ratch *h*, and thus as soon as the action of the latter ceases for a short time, which is the case when the circular part of the cam S', operates on the pawl T, then the spiral spring will force the shaft back, and thus press down the jaw L', and hold the cloth. The same motion just described takes place to the jaw L, which is moved by a similar arrangement by means of cam S.

The space between the jaws L and L' can be made for a certain measure, for instance one yard; thus the cloth will be measured at the same time it is folded. When the machine is running the blades do not move

with a uniform motion but stop momentarily when they arrive at the jaws; the cloth is rolled off from a roller and the impetus imparted to it is so great that more cloth
5 is fed into the blades than they can fold up, which would impede the working of the machine, to cause the cloth to be stretched between the roller D and the blades, the cross bar C presses it down between the rollers
10 B and D, thus causing sufficient friction and not letting the cloth pass faster over the roller D, than the blades can fold it up. This friction can be regulated by setting the roller B in the holes s, when the friction
15 will be moderate which may be necessary according to the quality of the cloth.

Having thus fully described the nature of

my invention, what I claim therein as new and desire to secure by Letters Patent is—

1. In connection with the pivoted vibrating blades E, E', the rod and swivel for causing said blades to make a half revolution during each vibration substantially as described. 20

2. I also claim the friction bar or brake 25 C, in combination with the rolls B, D, for preventing the cloth by the momentum of the blades from paying off faster than it is folded substantially as described.

J. D. ELLIOT.

Witnesses:

GEORGE JENKS,
LUTHER HILL.