



INTERNATIONAL APPLICATION PUBLISHED UNDER THE PATENT COOPERATION TREATY (PCT)

<p>(51) International Patent Classification ⁶ : F02B 75/32, F02F 7/00, F01B 1/06</p>	<p>A1</p>	<p>(11) International Publication Number: WO 95/13464 (43) International Publication Date: 18 May 1995 (18.05.95)</p>
---	-----------	--

<p>(21) International Application Number: PCT/GB94/02484 (22) International Filing Date: 11 November 1994 (11.11.94) (30) Priority Data: 9323291.6 11 November 1993 (11.11.93) GB (60) Parent Application or Grant (63) Related by Continuation US 08/165,969 (CIP) Filed on 10 December 1993 (10.12.93) (71)(72) Applicant and Inventor: GALVIN, George, Frederic [GB/GB]; 9 Christchurch Road, Sidcup, Kent DA15 7HG (GB). (74) Agent: PRATT, David, Martin; David Pratt & Co., 7 Parkhill Road, Sidcup, Kent DA15 7NW (GB).</p>	<p>(81) Designated States: AU, CA, GB, JP, US, European patent (AT, BE, CH, DE, DK, ES, FR, GB, GR, IE, IT, LU, MC, NL, PT, SE). Published With international search report.</p>
--	---

(54) Title: CRANK MECHANISM

(57) Abstract

A crank mechanism for an internal combustion engine comprises a cylinder (1), a piston (2) reciprocable within the cylinder, and a rotatable shaft (4). The piston (2) is in drivable connection with the shaft (4) via a connecting rod (3), a drive ring (5) and a torque lobe (6). The connecting rod (3) is pivotally fixed to the piston (2), and the drive ring (5) is rigidly attached to the free end of the connecting rod (3). The torque lobe (6) is a circular plate eccentrically mounted on the shaft (4) for rotation therewith about the axis thereof. The drive ring (5) is an annular sleeve which is a rotatable sliding fit around the rim of the torque lobe (6). The axis of the piston (2) is offset with respect to the centre of the output shaft (4), whereby rectilinear movement of the piston (2) is converted to rotary movement of the torque lobe (6) or vice versa.

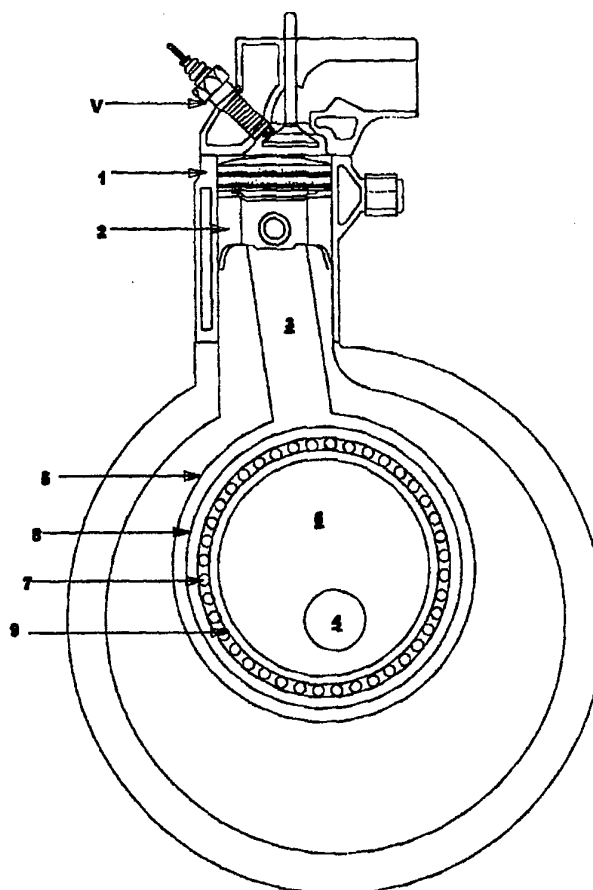

FOR THE PURPOSES OF INFORMATION ONLY

Codes used to identify States party to the PCT on the front pages of pamphlets publishing international applications under the PCT.

AT	Austria	GB	United Kingdom	MR	Mauritania
AU	Australia	GE	Georgia	MW	Malawi
BB	Barbados	GN	Guinea	NE	Niger
BE	Belgium	GR	Greece	NL	Netherlands
BF	Burkina Faso	HU	Hungary	NO	Norway
BG	Bulgaria	IE	Ireland	NZ	New Zealand
BJ	Benin	IT	Italy	PL	Poland
BR	Brazil	JP	Japan	PT	Portugal
BY	Belarus	KE	Kenya	RO	Romania
CA	Canada	KG	Kyrgystan	RU	Russian Federation
CF	Central African Republic	KP	Democratic People's Republic of Korea	SD	Sudan
CG	Congo	KR	Republic of Korea	SE	Sweden
CH	Switzerland	KZ	Kazakhstan	SI	Slovenia
CI	Côte d'Ivoire	LI	Liechtenstein	SK	Slovakia
CM	Cameroon	LV	Latvia	SN	Senegal
CN	China	LU	Luxembourg	TD	Chad
CS	Czechoslovakia	ML	Mali	TG	Togo
CZ	Czech Republic	MN	Mongolia	TJ	Tajikistan
DE	Germany			TT	Trinidad and Tobago
DK	Denmark			UA	Ukraine
ES	Spain			US	United States of America
FI	Finland			UZ	Uzbekistan
FR	France			VN	Viet Nam
GA	Gabon				

-1-

CRANK MECHANISM

This invention relates to a crank mechanism for an internal combustion engine.

A conventional internal combustion engine employs a crankshaft to convert the reciprocating motion of the piston(s) into output torque to propel a vehicle or to act upon any other load. The crankshaft is inefficient in terms of converting the power available from the fuel combustion into usable output torque. This is because combustion of the fuel/air mixture takes place at approximately the top dead centre (TDC) position of the piston. Not only the crankpin, but also the crankshaft main bearings, are consequently subjected to periodic heavy stresses. What is of greater significance, however, is that, with an internal combustion engine provided with conventional drive gear, the ignited fuel/air pressure forces cannot produce torque when the piston is either at TDC or bottom dead centre (BDC), as the connecting rod and the crankpin are practically in a straight line so that there is no force component tangential to the crank circle. This results in most of the available energy being lost as heat. The torque necessary to carry the crankshaft through these two dead centre positions is supplied by the inertia of the flywheel of the engine. Moreover, by the time the crankshaft has rotated through almost 90° beyond TDC, where the turning moment is a maximum, the piston force is greatly reduced, so that the resulting torque is relatively small.

My International patent application WO91/10848

-2-

describes a crank mechanism for an internal combustion engine, the crank mechanism comprising a cylinder, a piston reciprocable within the cylinder, and a rotatable shaft. The piston is in drivable connection with the shaft via a
5 connecting rod, a drive ring and a torque lobe. The connecting rod is pivotally fixed to the piston, and the drive ring is pivotally attached to the free end of the connecting rod. The torque lobe is a circular plate eccentrically mounted on the shaft for rotation therewith
10 about the axis thereof. The drive ring is slidable along, but restrained to, the rim of the torque lobe, and the drive ring is constrained to move around a closed path whereby rectilinear movement of the piston is converted to rotary movement of the torque lobe or vice versa. The drive
15 ring is provided with cam follower means which engage with associated cam track means adjacent to the torque lobe, the cam follower means and the cam track means constituting means for constraining the drive ring to move round the closed path.

20 A disadvantage of this crank mechanism is the need for the cam track means and the cam follower means, which complicate the design. Moreover, this mechanism requires an anti-reverse device for preventing the torque lobe from rotating in the reverse direction at BDC at the end of the
25 induction stroke.

The present invention provides a crank mechanism for an internal combustion engine, the crank mechanism comprising a cylinder, a piston reciprocable within the

-3-

cylinder, and a rotatable shaft, the piston being in drivable connection with the shaft via a connecting rod, a drive ring and a torque lobe, the connecting rod being pivotally fixed to the piston, and the drive ring being
5 rigidly attached to the free end of the connecting rod, wherein the torque lobe is a circular plate eccentrically mounted on the shaft for rotation therewith about the axis thereof, wherein the drive ring is an annular sleeve which is a rotatable sliding fit around the rim of the torque
10 lobe, and wherein the axis of the piston is offset with respect to the centre of the output shaft whereby rectilinear movement of the piston is converted to rotary movement of the torque lobe or vice versa.

This mechanism has the advantages of not requiring
15 either cam track/cam follower means or an anti-reverse device, and so is a simpler and more reliable mechanism than my earlier crank mechanism, whilst still having improved torque characteristics.

The invention also provides a crank mechanism for an
20 internal combustion engine, the crank mechanism comprising a plurality of cylinders, a respective piston reciprocable within each of the cylinders, and a rotatable shaft, each of the pistons being in drivable connection with the shaft via a respective connecting rod, a respective drive ring
25 and a respective torque lobe, each connecting rod being pivotally fixed to the associated piston, and each drive ring being rigidly attached to the free end of the associated connecting rod, wherein each torque lobe is a

-4-

circular plate eccentrically mounted on the shaft for rotation therewith about the axis thereof, wherein each drive ring is an annular sleeve which is a rotatable sliding fit around the rim of the associated torque lobe, and wherein the axis of each piston is offset with respect to the centre of the output shaft whereby rectilinear movement of the pistons is converted to rotary movement of the torque lobe or vice versa.

Preferably, the or each drive ring is a rolling fit on the rim of the associated torque lobe. In this case, the or each drive ring is mounted on the rim of the associated torque lobe by means of a respective rolling element bearing, whereby the rolling elements and the torque lobe rotate in the same direction, thereby increasing the turning moment of the torque lobe and hence that of the crank mechanism.

Advantageously, the axis of the or each piston is offset from the axis of the output shaft by a distance equal to substantially half the stroke of the associated piston.

In a preferred embodiment, the or each connecting rod is constituted by a main connecting rod and at least one auxiliary connecting rod, the or each auxiliary connecting rod being slidably fixed to the main connecting rod for axial movement relative thereto, the associated piston being fixed to the or each auxiliary connecting rod, and the main connecting rod being fixed to the associated drive ring. Conveniently, a respective pair of auxiliary

-5-

connecting rods are associated with the or each main connecting rod, the auxiliary connecting rods of the or each pair being positioned one on each side of the associated main connecting rod and being slidably fixed thereto by axial slots formed in the main connecting rod and pins projecting from the auxiliary connecting rods and passing through the slots. The or each auxiliary connecting rod may be associated with a respective cam fixed to the associated torque lobe. Where there are two auxiliary connecting rods associated with the or each main connecting rod, the two associated cams are fixed to opposite sides of the associated torque lobe.

Preferably, the or each cam is formed with a cam drive face which engages with the free end of the associated auxiliary connecting rod over the first 90° of movement of the associated piston during its power stroke, thereby applying a turning moment to said cam and hence to said cam and hence to said torque lobe. The or each cam may be formed with a return cam face which engages the free end of the associated auxiliary connecting rod during the movement of the associated piston in its exhaust stroke, and over the last 90° of movement of the said piston during its compression stroke.

Advantageously, the mechanism further comprises a respective spring associated with the or each auxiliary connecting rod, the or each spring being effective to hold the associated auxiliary connecting rod out of contact with its cam during the induction stroke of the associated

-6-

piston.

The addition of the auxiliary connecting rod(s) arranged to run parallel to the main connecting rod leads to a further improvement in the crank mechanism. This is because the or each piston imparts high turning moments via the associated cam(s) to the output shaft for the first 90° travel on the power stroke. The turning moment is closely matched to the power curve, thereby maximising the output power. The mechanism then reverts to the arrangement previously described for the second 90° travel of the power stroke, utilising the advantages of that system. The cam arrangement which includes the spring(s) has the advantage of a smooth action, as well as resetting the auxiliary connecting rods. It also creates a situation where resonance can occur provided by the rotating mass and spring compliance, such that the system will have a very high efficiency at a particular rotational speed.

Conveniently, there are six cylinders arranged in two banks of three cylinders, the cylinders in each bank being in a flat radial configuration. In this case, the three torque lobes associated with each bank of three cylinders may all be fixed to the output shaft in such a manner that the lines joining the centre of the output shaft to the centres of said torque lobes are angled to one another by 120°.

The invention will now be described in greater detail, by way of example, with reference to the accompanying drawings, in which:-

-7-

FIG. 1 is a schematic part-sectional elevation of a simplified form of internal combustion engine which illustrates the principle of the invention;

5 FIG. 2 is a schematic, partially broken away, perspective view of the engine of Fig. 1;

FIGS. 3a to 3d are diagrams illustrating different stages of the operation of the engine of Figs. 1 and 2;

10 FIGS. 4a to 4e are diagrams illustrating how improved torque is achieved with the engine of Figs. 1 and 2;

FIG. 5 is a perspective view of an internal combustion engine incorporating a modified form of the crank mechanism of Figs. 1 and 2;

15 FIG. 6 is a side elevation of the crank mechanism of Fig. 5, and shows the connecting rod in more detail; and

20 FIG. 7 is a plan view of a practical form of internal combustion engine incorporating the crank mechanism of Figs. 1 and 2.

Referring to the drawings, Figs. 1 and 2 show a simple form of internal combustion engine. The engine has a single cylinder 1 in which a piston 2 is reciprocable.

25 The piston-and-cylinder arrangement 1, 2 has a conventional valve arrangement indicated generally by the reference V, and can be powered by petrol, diesel or any other acceptable fuel. A connecting rod 3 is pivotally fixed to

-8-

the piston 2, the connecting rod rotatably driving an output shaft 4 via a drive ring 5 and a torque lobe 6. The connecting rod 3 is rigidly fixed to the drive ring 5. The torque lobe 6 is constituted by a circular plate, which is eccentrically mounted on the shaft 4. As shown best in Figs. 1 and 3, the axis of the piston 2 is offset with respect to the centre of the output shaft 4, that is to say the line of action of the piston does not pass through the centre of the output shaft.

10 As shown best in Fig. 2, the drive ring 5 is an annular sleeve which can slide round the torque lobe 6 as it rotates. The drive ring 5 is attached to a ring (not shown) fixed to the outer race 8 of a ball bearing 7 whose inner race 9 is fixed to the peripheral edge of the torque lobe 6. A roller bearing could be used in place of the ball bearing.

The operation of the single cylinder engine of Figs. 1 and 2 will now be described with reference to Figs. 3a to 3d. The operating cycle is best understood by describing the operation of a four-stroke cycle starting with the piston 2 at TDC. In this position (see Fig. 3a), the piston 2 has just completed its compression stroke, ignition having taken place just before TDC. The expanding gases formed by the ignition explosion force the piston 2 to descend rapidly within the cylinder 1, whereby the connecting rod 3 and the drive ring 5 force the torque lobe 6 to rotate to the position shown in Fig. 3b. This movement of the piston 2 is the power stroke of the engine. Further

-9-

rotation of the torque lobe 6 carries the piston 2 past BDC (see Fig. 3c), where appropriate action of the valve arrangement (not shown in this figure) causes the spent gases to be exhausted from the engine. The momentum of the torque lobe 6 and/or a flywheel (not shown) on the output shaft 4 carries the piston 2 upwards through the position shown in Fig. 3d and towards TDC. After the piston 2 is carried past TDC, the momentum of the flywheel forces the piston and the drive ring 5 down into the induction stroke (see Figs. 3a and 3b).

Once the piston 2 has passed BDC, it is carried upwards into the compression stroke (see Figs. 3c and 3d) by the momentum of the torque lobe 6 and/or the flywheel. The operating cycle then starts again with the piston 2, the drive ring 5 and the torque lobe 6 in the positions shown in Fig. 3a.

During the four strokes, the drive ring 5 is constrained to follow the rotation of the torque lobe 6 twice (see Fig. 6a), the TDC position of the piston 2 being offset from the axis of the shaft 4 by a distance equal to half the length of the stroke of the piston, or by a distance chosen to match the characteristics of the input energy. This enhances the torque produced by the engine by increasing the moment of the descending piston 2 about the axis of rotation (the axis of the shaft 4), in a manner described below with reference to Figs. 4a to 4e.

Figs. 4a to 4e show the principle underlying the derivation of the improved torque of the engine of Figs. 1

-10-

and 2. Fig 4a shows a conventional ball bearing 10, this bearing normally rotating about its own geometric axis 11 with either its inner ring 12 or its outer ring 13 held. However, if an external force F (see Fig. 4b) is applied to the outer ring 13, thereby causing the bearing 10 to rotate, this force produces a two-link mechanism whereby the balls 14 of the bearing 10 are rotated about their own axes in the direction opposite to that in which the inner ring 12 rotates, such that the balls rotate on the outer ring (which is not free to move). The combined effect of the external force F and the rotation of the balls 14 has the effect of moving the centre of the turning circle of the ball cage (not shown) by an amount x equal to the radius of the balls (see Fig. 4c).

Applying this theory to a conventional crank mechanism 15 (see Fig. 4d), it can be seen that the crank pin 16 rotates in the direction of the arrow A, this direction being opposite to the direction B of rotation of the output shaft 17 of the mechanism 15. Thus, the output shaft 17 rotates in the opposite direction to that (C) in which the balls of the bearing rotate. The resultant shift (not shown) of the centre of the turning circle of the ball cage, therefore, has the effect of reducing the overall turning moment of the output shaft by the ratio of ball radius to crank throw radius (that is to say the distance between the centres of the crank pin 16 and the output shaft 17). If, however, this principle is applied to the torque lobe mechanism of Figs. 1 and 2, the output shaft 4

-11-

(see Fig. 4e) rotates in the same direction B as that (A) in which the torque lobe 6 rotates. Thus, the output shaft 4 rotates in the same direction as that (C) in which the balls of the bearing 7 rotate. The shift (not shown) of the centre of the turning circle of the balls will, therefore, assist the overall turning moment of the output shaft 4 by the ratio of ball radius to centre-of-lobe to centre-of-output shaft distance (that is to say the turning moment). As the piston 2 is offset with respect to the centre of the output shaft 4, this assists the overall improvement by increasing the force applied to the torque lobe 6 by the inverse cosine (secant) of the angle between the axes of the connecting rod 3 and the piston.

Clearly, the larger the bearing ball diameter for a given torque lobe turning moment the greater the overall power output from the engine within engineering limits.

Fig. 5 shows an internal combustion engine incorporating a modified form of the crank mechanism of Figs. 1 and 2. This engine has a further increase in turning moment when compared with the engine which incorporates the crank mechanism of Figs. 1 and 2. This modified crank mechanism is similar to that of Figs. 1 and 2, so like reference numerals will be used for like parts, and only the modifications will be described in detail. Thus, the connecting rod 3 of the Fig. 5 embodiment is provided with a pair of auxiliary connecting rods 21 which are constrained to move parallel to the main connecting rod by pins 22a and 23a projecting from the auxiliary

-12-

connecting rods and passing through axial slots 23a and 23b formed in the main connecting rod. The upper pin 22a is a gudgeon pin connecting the auxiliary connecting rods 21 to the piston 2. The lower pin 22b constrains the auxiliary
5 connecting rods 21 to be parallel to the main connecting rod 3 which is in rigid connection with the drive ring 5.

Two external cams 24 are provided, being fixed to the torque lobe 6 on opposite sides thereof. The cams 24 each have a curved drive face 24a and a curved return face
10 24b which meet at an apex portion 24c, the portion of the cam between the drive and return faces constituting a non-camming face 24d. As shown in Fig. 6, the apex portion 24c is coincident with the axis of the movement of the piston 2 at TDC. The piston 2 is at TDC at the commencement of
15 its power stroke. Pressure in the cylinder 1 will cause the piston 2 to move down, thereby driving the auxiliary connecting rods 21 along the inclined drive faces 24a of the cams 24. A considerable turning moment will be exerted on these cam faces 24a which, in turn, will rotate the
20 torque lobe 6, the cams 24, the bearing 7 and the drive ring 5.

When the torque lobe 6 and attachments are at approximately 90° after TDC, the pins 22a and 22b will reach the lower ends of the slots 23a and 23b. Here, the cam
25 faces 24d have been relieved such that the auxiliary connecting rods 21 no longer apply force to the cams 24. This force is now transferred to the main connecting rod 3 by the engagement of the pins 22a and 22b with the lower

-13-

ends of the slots 23a and 23b. The mechanism now behaves for the remaining 90° of the power stroke as the mechanism shown in Figs. 1 and 2. This transfer of force from the cams 24 to the drive ring 5 and the torque lobe 6 is necessary because the turning moment exerted by the auxiliary connecting rods 21 at this point (90° after TDC) reduces below that which can be exerted by the main connecting rod 3. This maximises the overall turning moment on the power stroke.

On completion of the power stroke, the piston 2 is required to be returned to its starting position (with the pins 22a and 22b at the upper ends of the slots 23a and 23b) during the exhaust stroke. The return faces 24b of the cams 24 provide this function, enabling the auxiliary connecting rods 21 to be raised by the cams 24 such that all are returned to their same positions as at the commencement of the power stroke. As the engine continues to rotate past TDC, it commences its induction stroke, the inlet valve is open and the piston is descending. A partial vacuum is created in the cylinder 1 holding the auxiliary connecting rods 21 and the piston 2 such that the pins 22a and 22b are held at the upper ends of the slots 23a and 23b. It is necessary to hold the piston 2 and the auxiliary connecting rods 21 in this position to prevent physical contact of the auxiliary connecting rods with the cams 24 which would otherwise be caused by the inertia gained by these rods and the piston, their having been accelerated over the first 90° of the induction stroke.

-14-

Springs 25 (one for each auxiliary connecting rod) provide the function of holding the auxiliary connecting rods 21 and the piston 2 in the positions where the pins 22a and 22b are at the upper ends of the slots 23a and 23b for the 5 180° rotation of the induction cycle. This also ensures that the induction stroke is not increased, which could occur, due to the descent of the piston 2 and the auxiliary connecting rods 21 had the springs 25 not been provided.

On completion of the induction stroke, the 10 compression stroke commences. As the torque lobe 6 passes through BDC, the increasing compression in the cylinder 1 will cause the auxiliary connecting rods 21 and the piston 2 to descend gradually. By about 90° before TDC, the auxiliary connecting rods 21 will touch the return faces 15 24b of the cams 24 and thereafter will be lifted on these cam faces to TDC for the next power stroke.

Clearly the inclusion of the springs 25 in this mechanism will cause the storing of some energy during the power stroke, but this energy will be returned to the 20 system on the exhaust stroke as the springs return to their rest positions.

Because the auxiliary connecting rods 21 and the piston 2 are free to move relative to the main connecting rod 3, the power stroke is increased by 50%. This extra 25 movement does not occur on the induction stroke due to the springs 25 holding the auxiliary connecting rods 21 with the pins 22a and 22b at the upper ends of the slots 23a and 23b. This means that the pressure that would have been

-15-

released in a conventional engine when the exhaust valve opens at approximately 20°-30° before BDC, is able to be utilised to create turning moment, thereby expending more energy in output as opposed to exhaust heat.

5 Clearly, the engine of Figs. 1 and 2 produces an average torque which is substantially larger than that of the conventional engine, with the engine of Fig. 5 being even further improved. To summarise, the torque lobe arrangement of the crank mechanism of the present
10 invention, in utilising the turning moment of the balls, and by the piston offset more closely matching the 'moment curve' to the 'pressure curve', greatly enhances the mechanical efficiency of the process of converting
reciprocating motion to output torque.

15 Fig. 7 shows a practical form of internal combustion engine incorporating the crank mechanism of Figs. 1 and 2, this engine having two banks (only one of which can be seen - the other being directly behind) of three cylinders 31, each acting on a respective torque lobe 36. Each cylinder
20 31 has a respective piston 32, connecting rod 33 and drive ring 35, and its torque lobe 36 is eccentrically mounted on a common output shaft 34. A respective drive ring 35 is attached to a ring (not shown) fixed to the outer race of a respective roller bearing 37 whose inner race is fixed to
25 the peripheral edge of the associated torque lobe 36. Each drive ring 35 is rigidly attached to its associated connecting rod 33. The torque lobes 36 of each bank are rigidly attached to each other and to the output shaft 34

-16-

for rotation therewith. Each bank of cylinders 31 is a flat radial configuration with the output shaft 34 acting vertically downwards into a gear box (not shown). The six cylinders 31 are arranged to fire in the order 1 4 2 5 3 6.

5 This would require a distributor (not shown) to initiate a spark on both exhaust and compression strokes, and would enable the distributor to be driven directly from the output shaft 34 with no gearing. The whole arrangement, if applied to a four-stroke engine, would need inertia

10 (provided by the lobe masses) to conserve momentum. Balancing for the oscillating mass of the pistons 32 can be provided by arranging the two banks of cylinders 31 such that the cylinders diametrically opposite one another fire together.

15 Obviously, the engine of Fig. 7 could, alternatively, incorporate the crank mechanism of Figs. 5 and 6 in place of the crank mechanism of Figs. 1 and 2.

A particular advantage of either of the crank mechanisms described above is that, by improving the

20 overall efficiency of the associated engine, the loss of energy in the form of heat is substantially reduced, thereby reducing (or even eliminating) the need for engine cooling. This will lead to further improvements in the efficiency with which an associated vehicle is propelled,

25 as the overall weight of the vehicle can be reduced by removing the need for components such as a cooling fan, a water pump, a water jacket and a radiator.

Each of the crank mechanisms described above has a

-17-

reduced crankshaft length compared with a conventional crankshaft, and so can be used in any of the presently accepted multi-cylinder arrangements, that is to say radial, straight, flat or V-formation. This type of mechanism can also be used with any appropriate number of cylinders.

It would also be possible to operate any of the engines described above on a two-stroke cycle. The crank mechanism of the invention could also be incorporated in other forms of reciprocating engine such as a steam engine. Obviously, such a crank mechanism could also form part of a pump, for converting rotary motion of an input shaft to reciprocatory motion of a piston within a cylinder. Such a pump would have a much greater efficiency than a conventionally-cranked device. Indeed, the crank mechanism of the invention can be used with considerable advantage in any form of reciprocating/rotary or rotary/reciprocating arrangement, in any single or multi-cylinder configuration, and with any suitable fuel.

The engine of Figs. 5 and 6, which uses cams and springs, would be particularly suitable for a constant-speed engine arrangement running at its "resonant frequency", and may be applied as an "on-board" engine for an electrically-propelled car where the engine can be used very efficiently to charge the car batteries whilst the car is running.

CLAIMS

1. A crank mechanism for an internal combustion engine, the crank mechanism comprising a cylinder, a piston reciprocable within the cylinder, and a rotatable shaft, the piston being in drivable connection with the shaft via a connecting rod, a drive ring and a torque lobe, the connecting rod being pivotally fixed to the piston, and the drive ring being rigidly attached to the free end of the connecting rod, wherein the torque lobe is a circular plate eccentrically mounted on the shaft for rotation therewith about the axis thereof, wherein the drive ring is an annular sleeve which is a rotatable sliding fit around the rim of the torque lobe, and wherein the axis of the piston is offset with respect to the centre of the output shaft whereby rectilinear movement of the piston is converted to rotary movement of the torque lobe or vice versa.

2. A crank mechanism for an internal combustion engine, the crank mechanism comprising a plurality of cylinders, a respective piston reciprocable within each of the cylinders, and a rotatable shaft, each of the pistons being in drivable connection with the shaft via a respective connecting rod, a respective drive ring and a respective torque lobe, each connecting rod being pivotally fixed to the associated piston, and each drive ring being rigidly attached to the free end of the associated connecting rod, wherein each torque lobe is a circular plate eccentrically mounted on the shaft for rotation therewith about the axis thereof, wherein each drive ring

-19-

is an annular sleeve which is a rotatable sliding fit around the rim of the associated torque lobe, and wherein the axis of each piston is offset with respect to the centre of the output shaft whereby rectilinear movement of the pistons is converted to rotary movement of the torque lobe or vice versa.

3. A crank mechanism as claimed in claim 1 or claim 2, wherein the or each drive ring is a rolling fit on the rim of the associated torque lobe.

10 4. A crank mechanism as claimed in claim 3, wherein the or each drive ring is mounted on the rim of the associated torque lobe by means of a respective rolling element bearing, whereby the rolling elements and the torque lobe rotate in the same direction, thereby increasing the turning moment of the torque lobe and hence that of the crank mechanism.

15 5. A crank mechanism as claimed in any one of claims 1 to 4, wherein the axis of the or each piston is offset from the axis of the output shaft by a distance equal to substantially half the stroke of the associated piston.

20 6. A crank mechanism as claimed in any one of claims 1 to 5, wherein the or each connecting rod is constituted by a main connecting rod and at least one auxiliary connecting rod, the or each auxiliary connecting rod being slidably fixed to the main connecting rod for axial movement relative thereto, the associated piston being fixed to the or each auxiliary connecting rod, and the main connecting rod being fixed to the associated drive ring.

-20-

7. A crank mechanism as claimed in claim 6, wherein a respective pair of auxiliary connecting rods are associated with the or each main connecting rod, the auxiliary connecting rods of the or each pair being
5 positioned one on each side of the associated main connecting rod and being slidably fixed thereto by axial slots formed in the main connecting rod and pins projecting from the auxiliary connecting rods and passing through the slots.

10 8. A crank mechanism as claimed in claim 6 or claim 7, wherein the or each auxiliary connecting rod is associated with a respective cam fixed to the associated torque lobe.

15 9. A crank mechanism as claimed in claim 8 when appendant to claim 7, wherein the two cams associated with the or each torque lobe are fixed to opposite sides of said torque lobe.

20 10. A crank mechanism as claimed in any one of claims 7 to 9, wherein the or each cam is formed with a cam drive face which engages with the free end of the associated auxiliary connecting rod over the first 90° of movement of the associated piston during its power stroke, thereby applying a turning moment to said cam and hence to said torque lobe.

25 11. A crank mechanism as claimed in claim 10, wherein the or each cam is formed with a return cam face which engages the free end of the associated auxiliary connecting rod during the movement of the associated piston in its

-21-

exhaust stroke, and over the last 90° of movement of the said piston during its compression stroke.

12. A crank mechanism as claimed in claim 10 or claim 11, further comprising a respective spring associated
5 with the or each auxiliary connecting rod, the or each spring being effective to hold the associated auxiliary connecting rod out of contact with its cam during the induction stroke of the associated piston.

13. A crank mechanism as claimed in claim 2, or in
10 any one of claims 3 to 12 when appendant to claim 2, wherein there are six cylinders arranged in two banks of three cylinders, the cylinders in each bank being in a flat radial configuration.

14. A crank mechanism as claimed in claim 13,
15 wherein the three torque lobes associated with each bank of three cylinders are all fixed to the output shaft in such a manner that the lines joining the centre of the output shaft to the centres of said torque lobes are angled to one another by 120°.

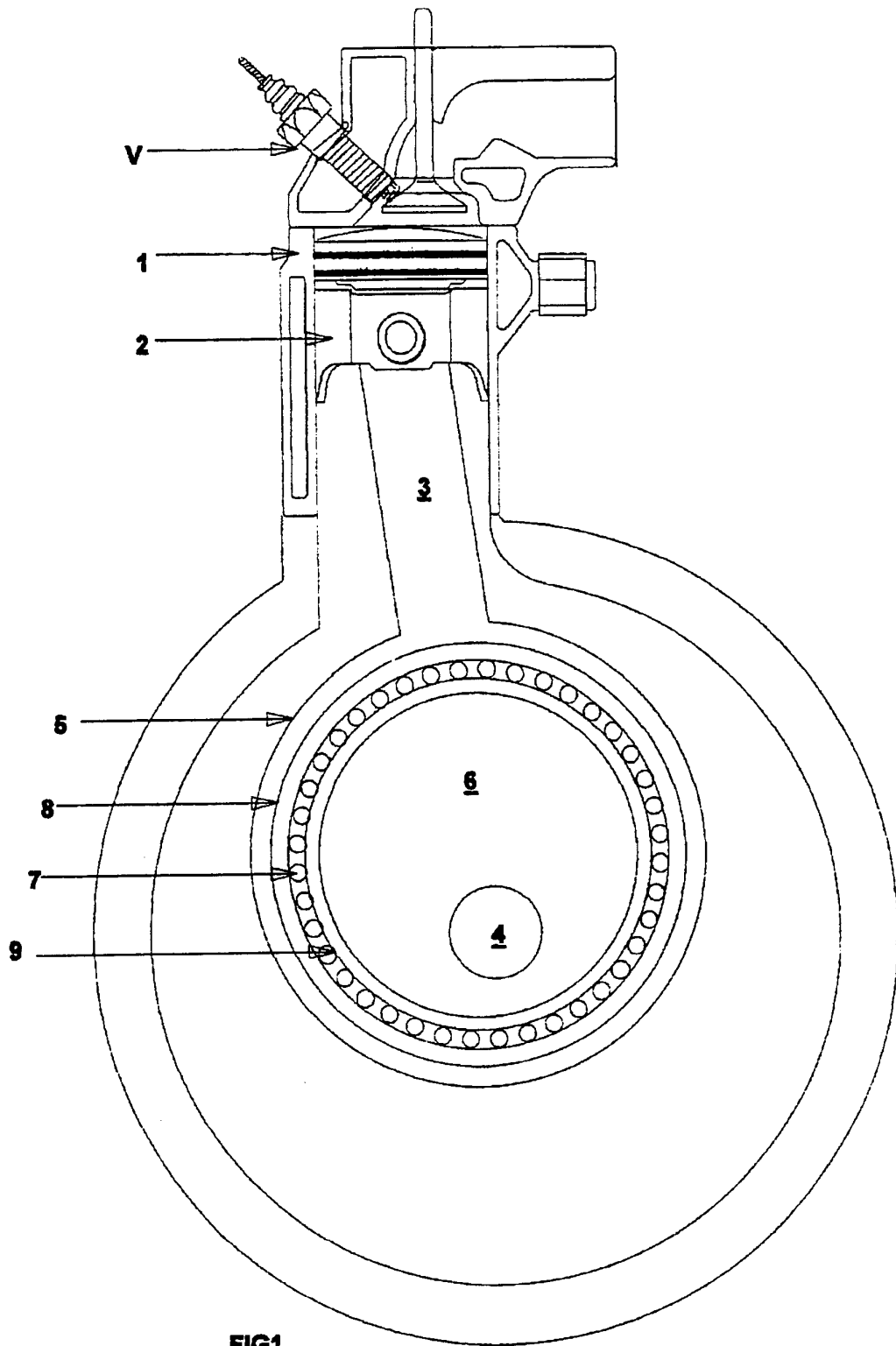

FIG1

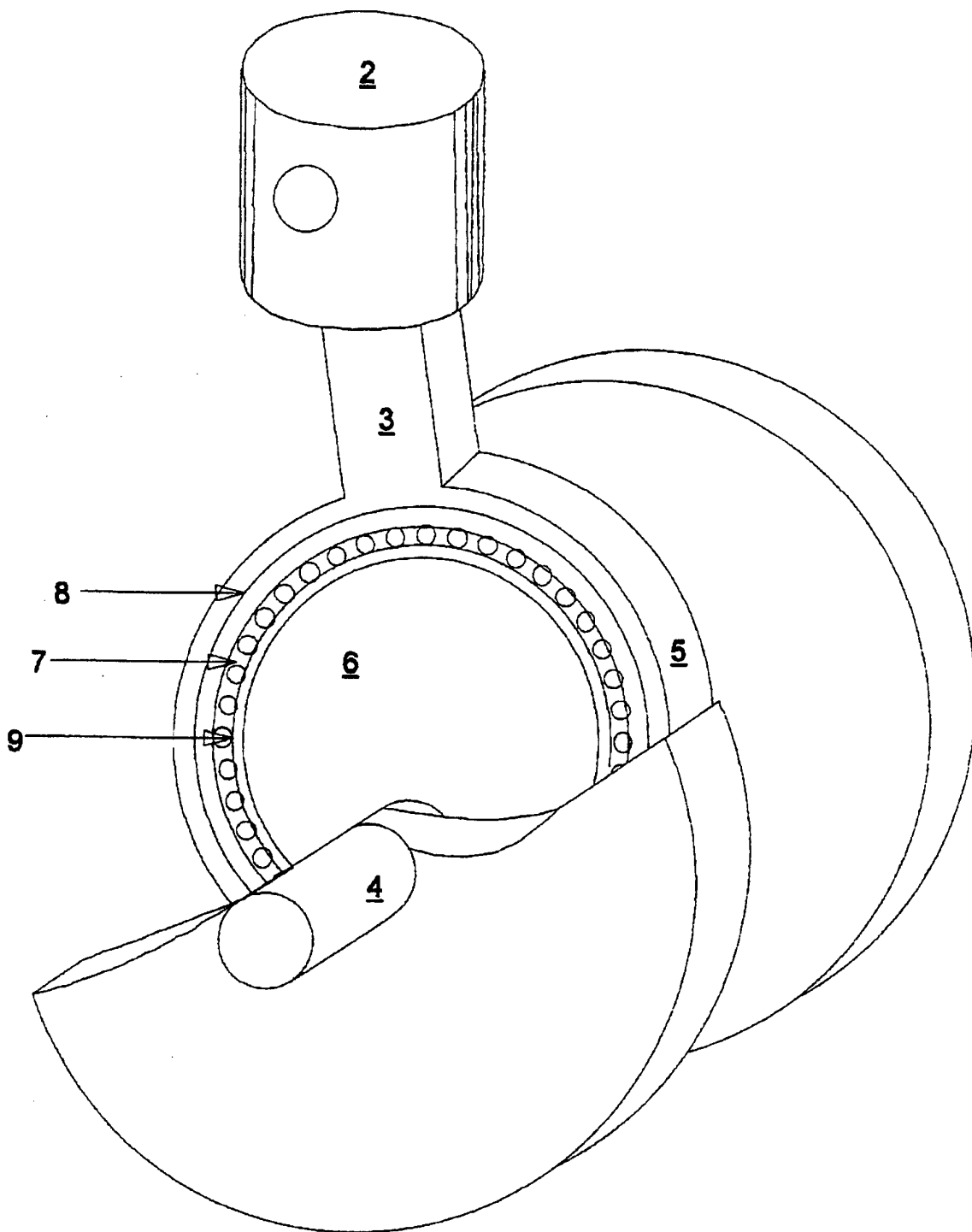

FIG 2

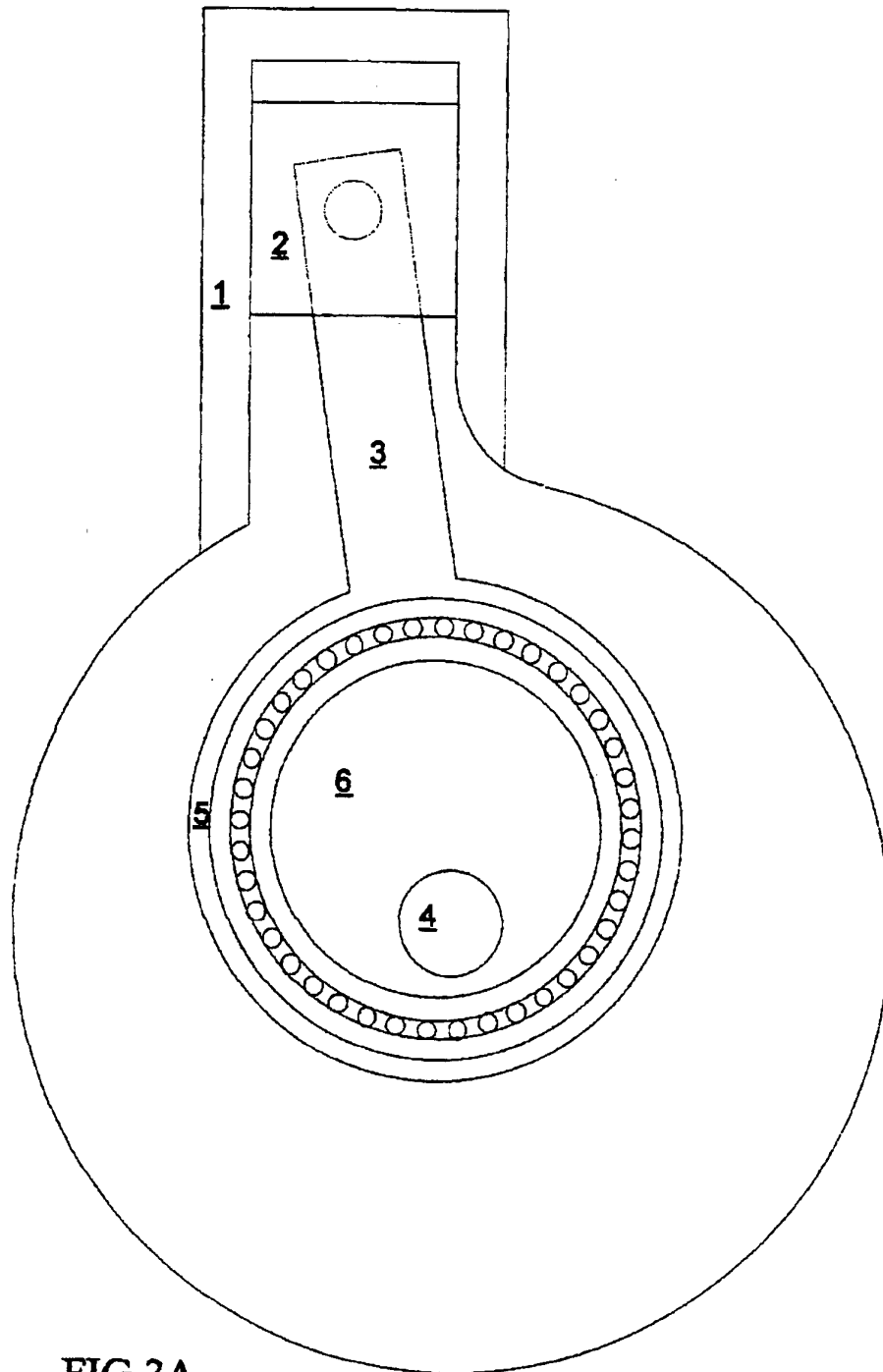

FIG 3A

4/11

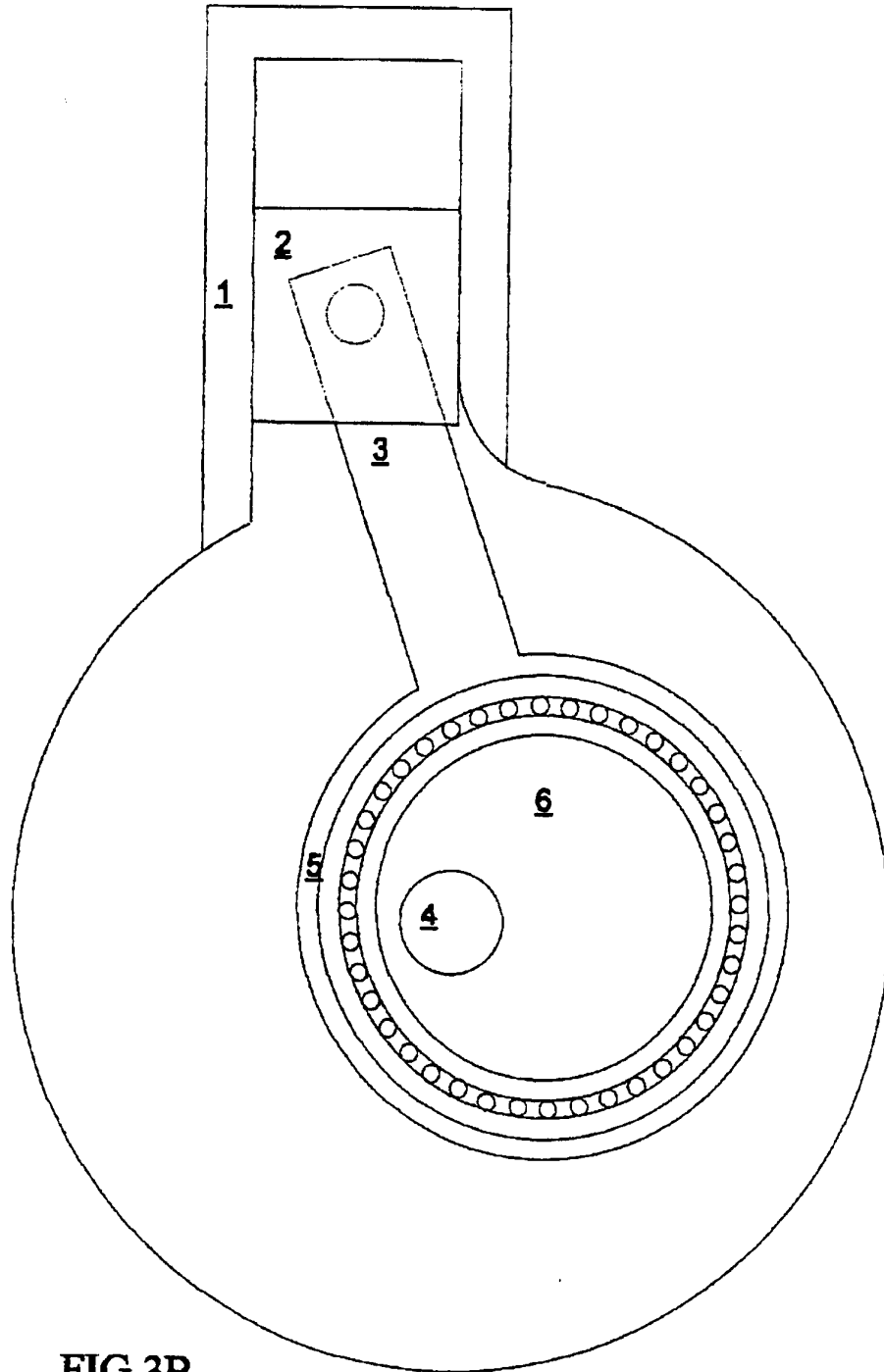

FIG 3B

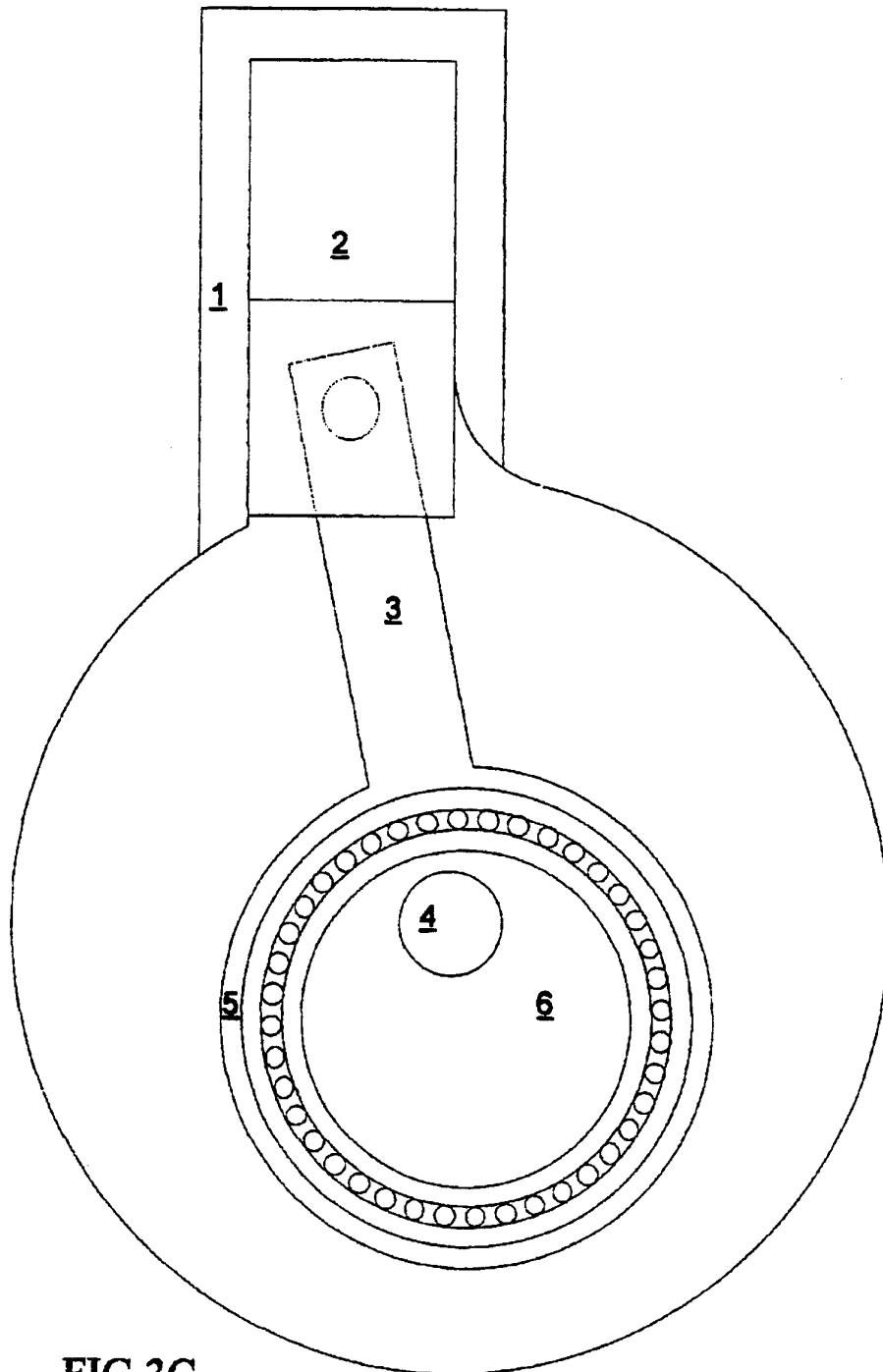

FIG 3C

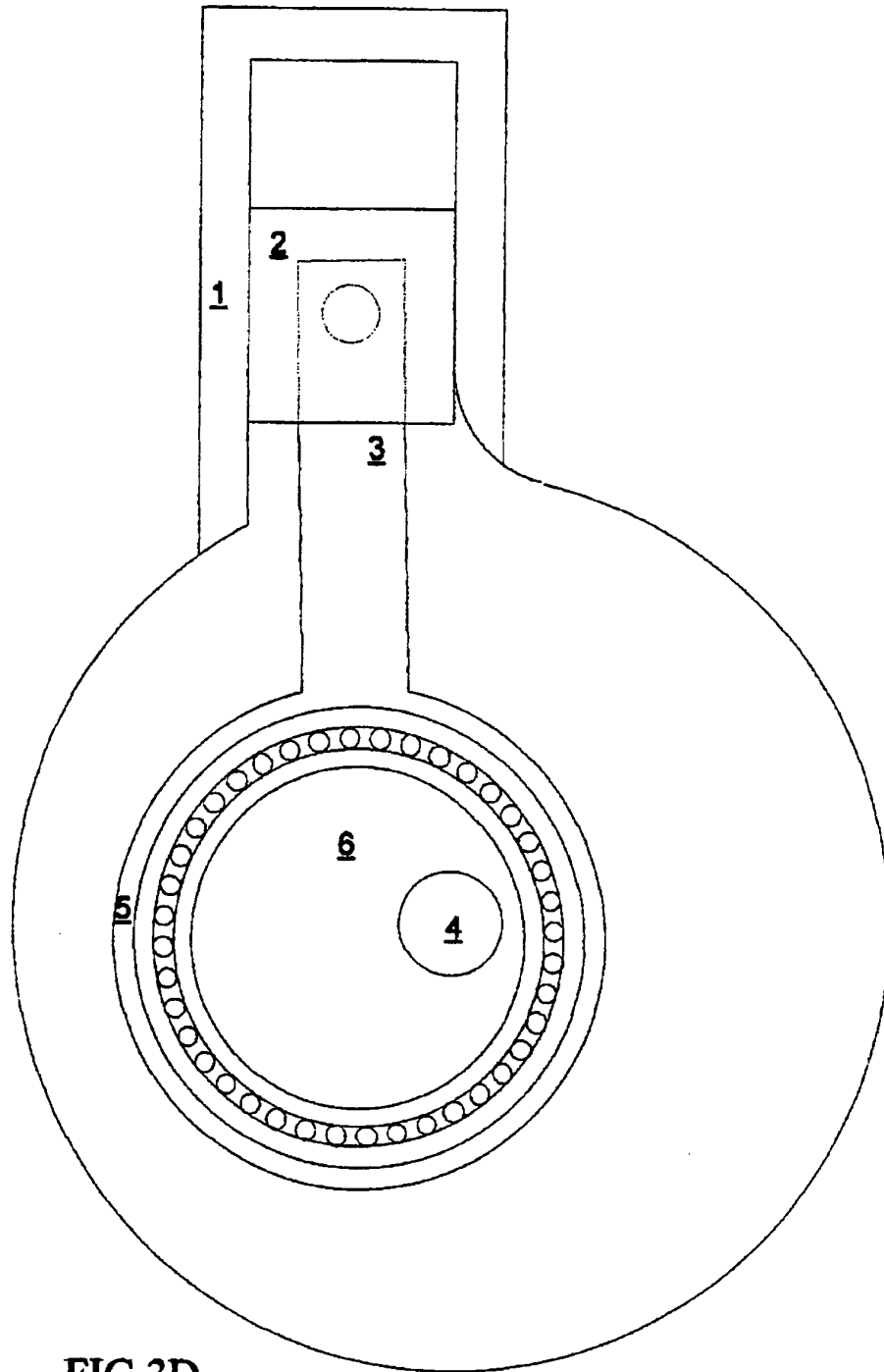

FIG 3D

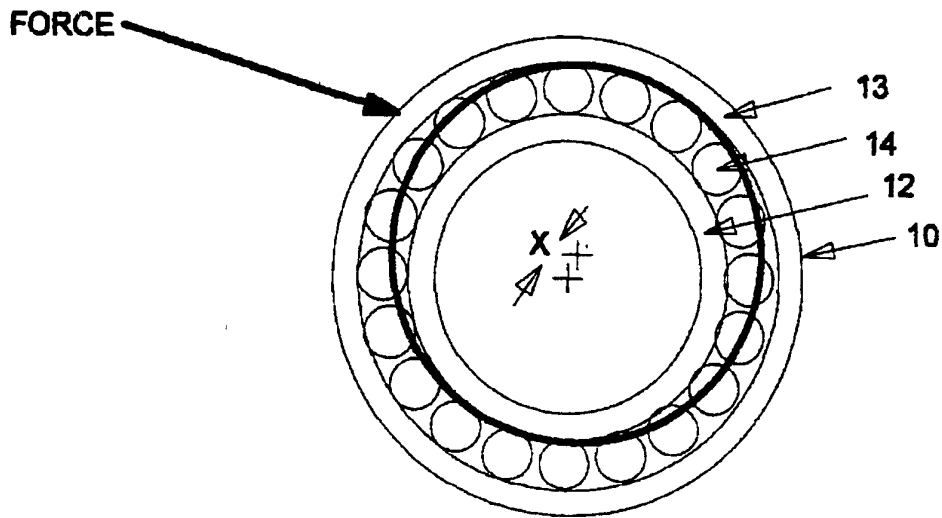
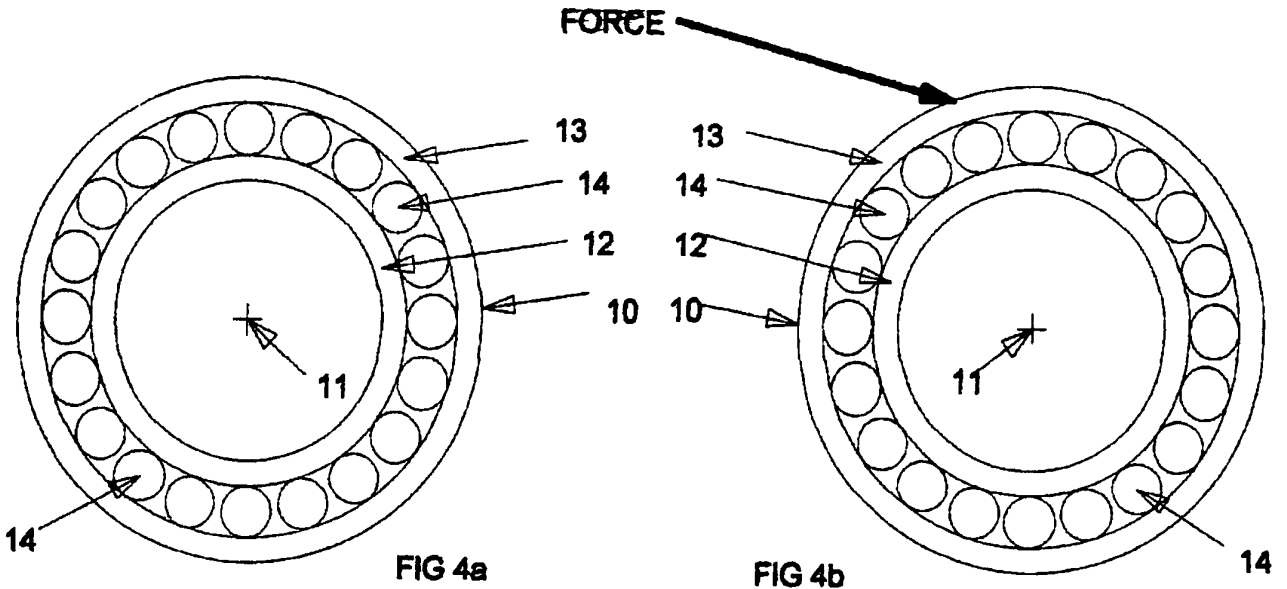

FIG 4c

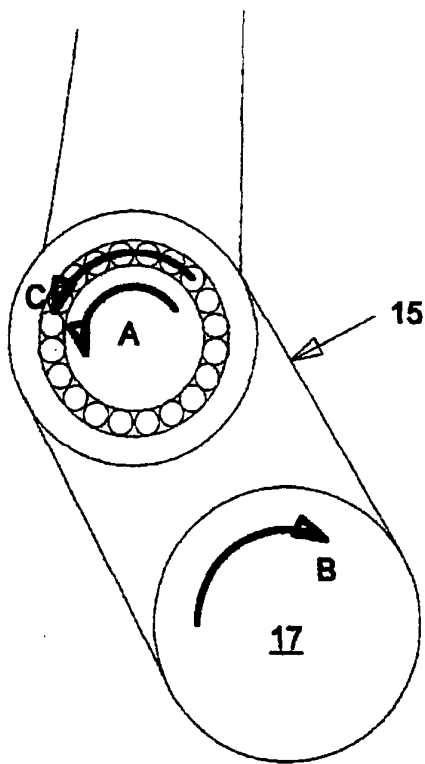

FIG 4d

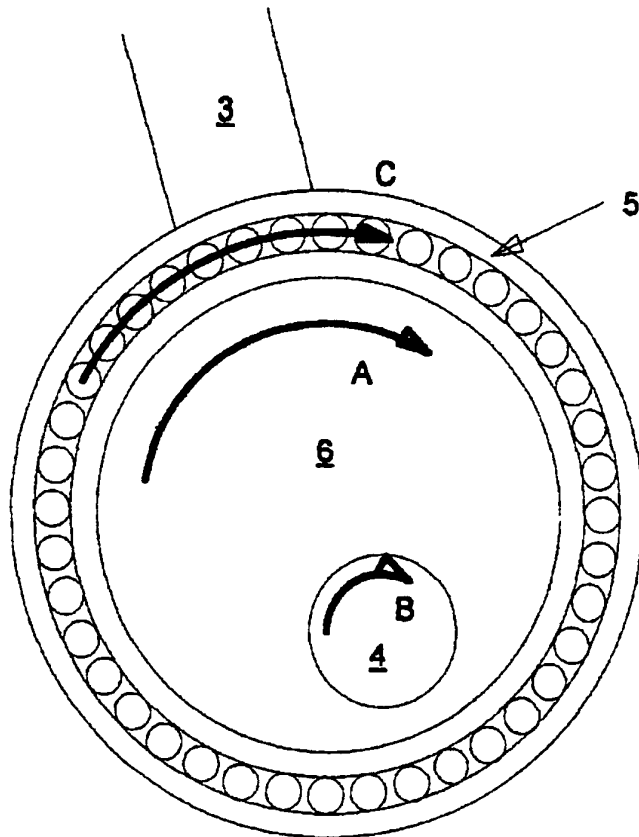

FIG 4e

9/11

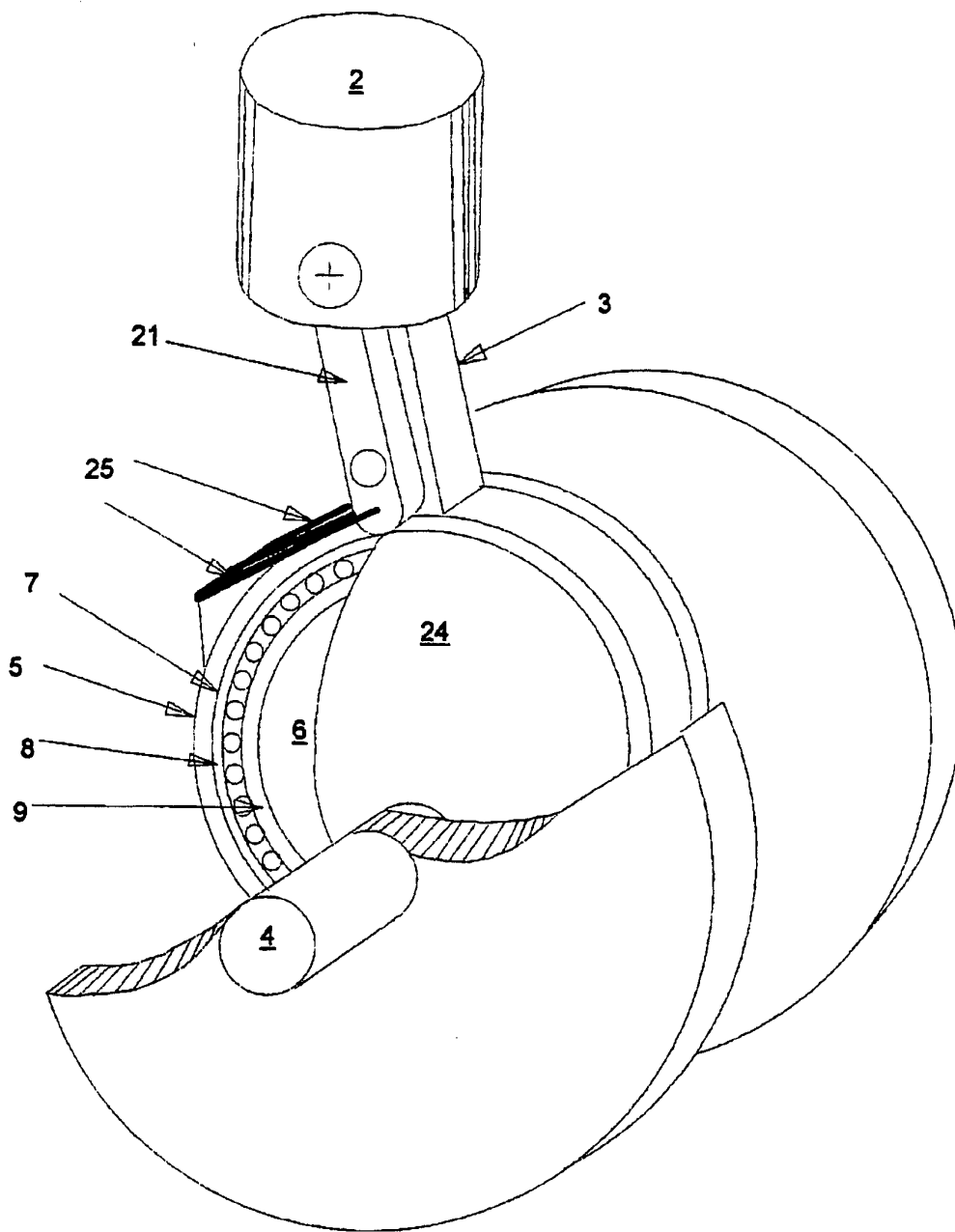

FIG 5

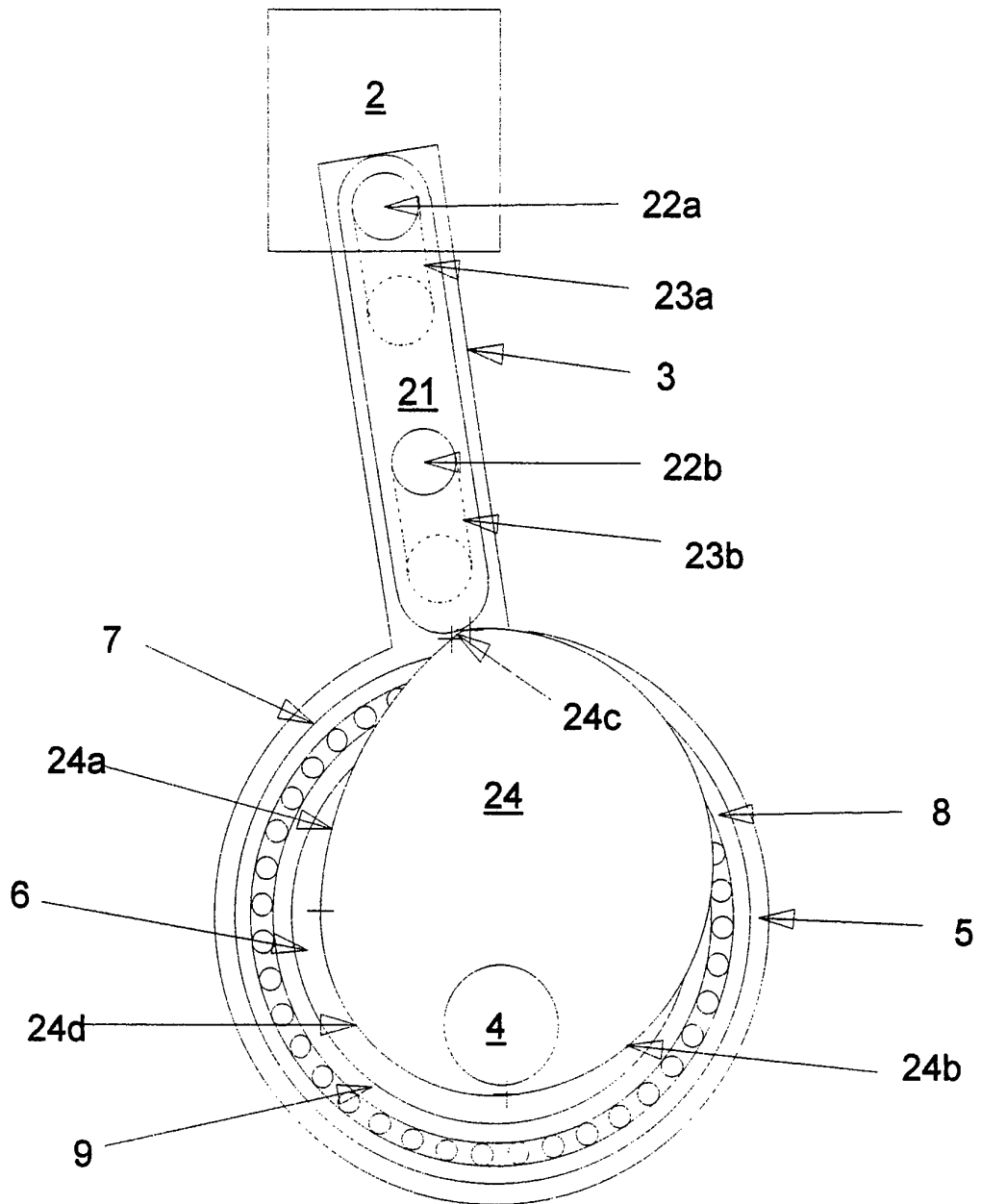

FIG 6

11/11

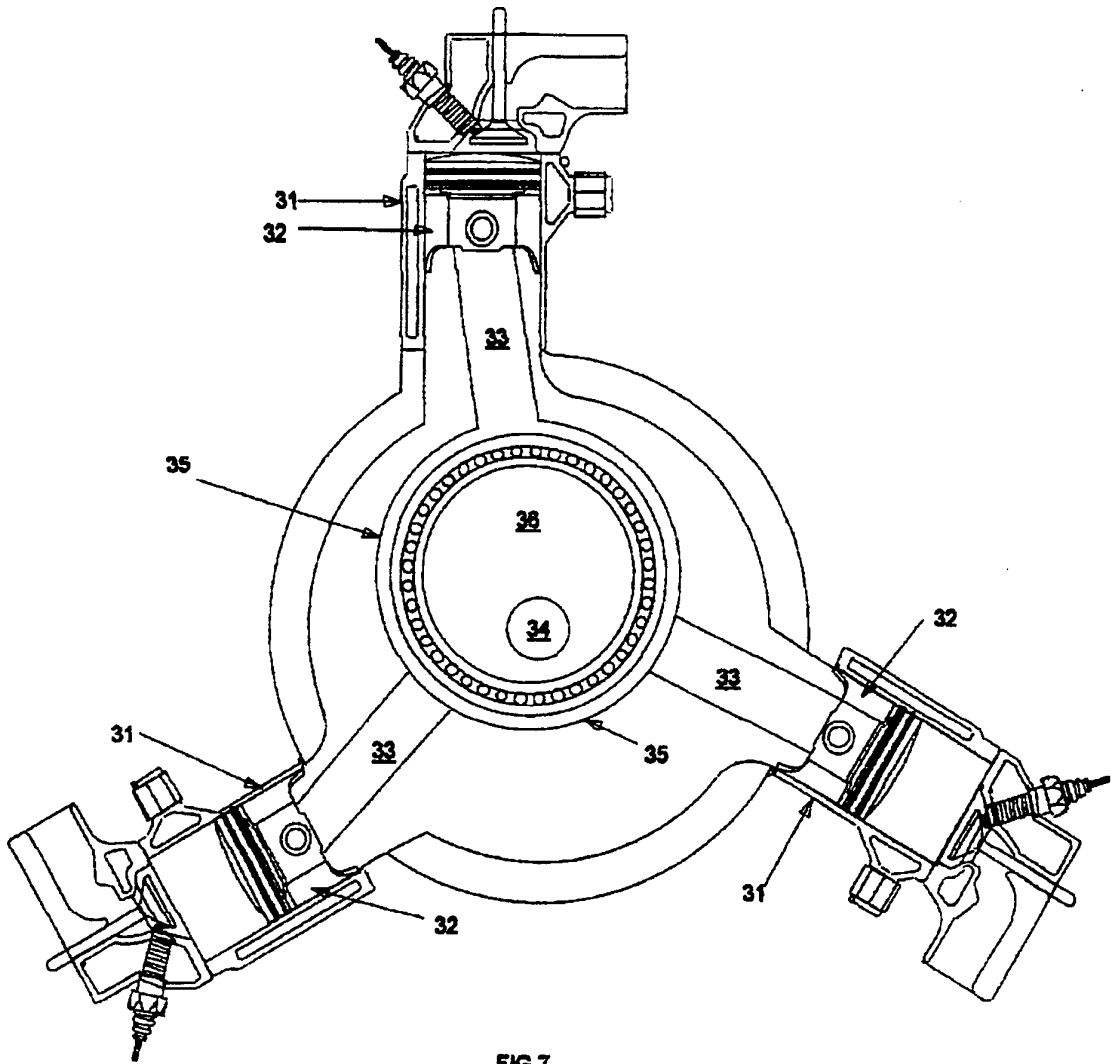

FIG 7

INTERNATIONAL SEARCH REPORT

Internat'l Application No
PCT/GB 94/02484

A. CLASSIFICATION OF SUBJECT MATTER
IPC 6 F02B75/32 F02F7/00 F01B1/06

According to International Patent Classification (IPC) or to both national classification and IPC

B. FIELDS SEARCHED

Minimum documentation searched (classification system followed by classification symbols)
IPC 6 F02B F02F F01B

Documentation searched other than minimum documentation to the extent that such documents are included in the fields searched

Electronic data base consulted during the international search (name of data base and, where practical, search terms used)

C. DOCUMENTS CONSIDERED TO BE RELEVANT

Category *	Citation of document, with indication, where appropriate, of the relevant passages	Relevant to claim No.
X	DE,U,89 14 968 (HÄBERLE) 17 May 1990 see the whole document ---	1
A	US,A,3 366 073 (DOWTY TECHNICAL DEVELOPMENTS LTD) 30 January 1968 see abstract; figures ---	2
A	GB,A,496 501 (THE WHITEHEAD TORPEDO COMPANY LTD) 1 December 1938 see page 1, line 29 - line 78 see figures -----	3,4

Further documents are listed in the continuation of box C.

Patent family members are listed in annex.

* Special categories of cited documents :

- *A* document defining the general state of the art which is not considered to be of particular relevance
- *E* earlier document but published on or after the international filing date
- *L* document which may throw doubts on priority claim(s) or which is cited to establish the publication date of another citation or other special reason (as specified)
- *O* document referring to an oral disclosure, use, exhibition or other means
- *P* document published prior to the international filing date but later than the priority date claimed

- *T* later document published after the international filing date or priority date and not in conflict with the application but cited to understand the principle or theory underlying the invention
- *X* document of particular relevance; the claimed invention cannot be considered novel or cannot be considered to involve an inventive step when the document is taken alone
- *Y* document of particular relevance; the claimed invention cannot be considered to involve an inventive step when the document is combined with one or more other such documents, such combination being obvious to a person skilled in the art.
- * & * document member of the same patent family

Date of the actual completion of the international search

1 February 1995

Date of mailing of the international search report

24.02.95

Name and mailing address of the ISA
European Patent Office, P.B. 5818 Patentlaan 2
NL - 2280 HV Rijswijk
Tel. (+ 31-70) 340-2040, Tx. 31 651 epo nl,
Fax: (+ 31-70) 340-3016

Authorized officer

Klinger, T

INTERNATIONAL SEARCH REPORT

Information on patent family members

International Application No

PCT/GB 94/02484

Patent document cited in search report	Publication date	Patent family member(s)	Publication date
DE-U-8914968	05-04-90	NONE	
US-A-3366073	30-01-68	NONE	
GB-A-496501		NONE	