

*J. A. Bradsham,*  
*Planing Shingles.*

*N<sup>o</sup> 11,774.*

*Patented Oct. 10, 1854.*

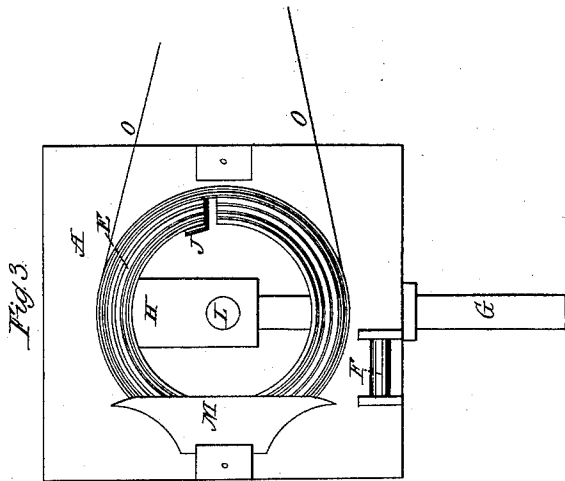
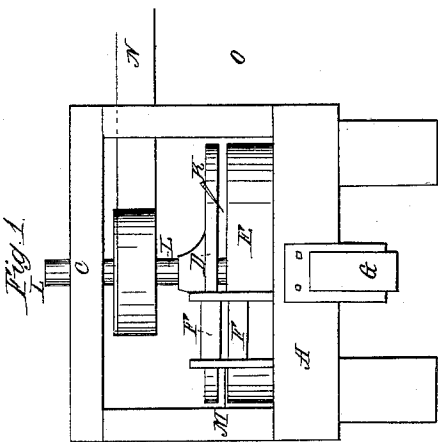
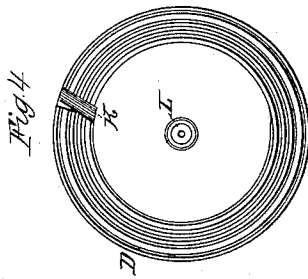
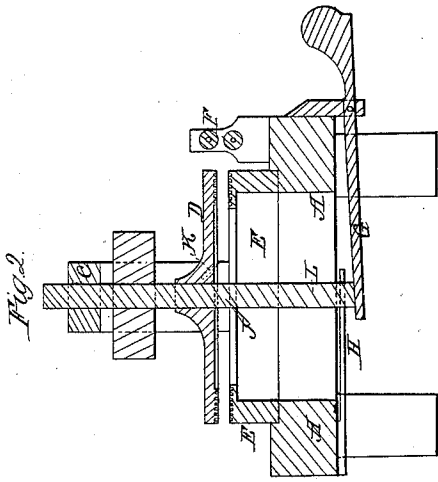

*Witnesses*  
*A. S. L. Davis*  
*M. G. Merrick*

*Inventor*  
*John A. Bradsham*

# UNITED STATES PATENT OFFICE.

JOHN A. BRADSHAW, OF LOWELL, MASSACHUSETTS.

## SHINGLE-MACHINE.

Specification of Letters Patent No. 11,774, dated October 10, 1854.

*To all whom it may concern:*

Be it known that I, J. A. BRADSHAW, of Lowell, in the State of Massachusetts, have invented a new and useful Improvement in the Machine for Shaving or Planing Shingles, of which the following is a full, clear, and exact description, reference being had to the accompanying drawings, making part of this specification, in which—

Figure 1, is an elevation of the machine; Fig. 2, a vertical section; Fig. 3, a horizontal section just below the upper cutter wheel, and Fig. 4, an inverted view of the upper cutter wheel.

The same letters indicate like parts in all the figures.

In my improved machine, the shingle bolts are fed into the machine by means of two feed rollers, and thence pass between two revolving rims, armed with cutters, and having their annular surfaces cut into a scroll or volute formed thread, cut in reversed directions on the two, the action of which on the opposite surfaces of the shingle block will tend constantly to carry it forward and laterally toward a fixed guide at the side and lying between the two cutter rims.

The accompanying drawings represent a suitable frame with a table (A,) having a circular aperture in the center. To the upper part of this aperture is fitted a rim (E) or annulus, which is fitted to turn therein freely, but accurately. It projects sufficiently above the table (A) to receive a strap (O) from some suitable motor. The upper surface of this rim is formed with a volute or scroll thread extending from the outer to the inner periphery, and a recess is formed in this rim to which is fitted a plane iron, (J) of suitable construction. Above this rim, and concentric therewith, is a corresponding rim (D) inverted, and with a thread in like manner but in the reverse direction, and also provided with a cutter or plane iron, (K). This rim forms part of a wheel, mounted on a vertical shaft (L), journaled in a cross bar (C), of the frame at top and one (H), at bottom; the journals are of sufficient length to slide up and down in the boxes, the lower end resting on a step at one end of a balance lever (G) so weight-

ed at the other end as nearly to balance the weight of the wheel and shaft, that the rim may have just sufficient tendency to descend to keep the surface in cutting contact with the surface of the shingle, and yet be free to follow the varying thickness of the shingle as it passes through. Between the two rims there is a guide (M) to keep the shingle in the proper direction, as it passes between the two cutters. And in front there is a pair of feed rollers (F) mounted, and operated, in the usual manner of feed rollers, and therefore not necessary to be described.

The shaft (L) is provided with a pulley to receive a strap (N) from some suitable motor. The speed of the two rims should be about equal and in the same directions.

The shingle blocks are fed in successively by the feed rollers, and as they enter one by one, between the two rims, the action of the two volute threads will not only carry them forward, but also laterally, against the guide (M) to insure their proper position as they are planed.

The rotation of the two rims, with their cutters, will shave the two opposite surfaces of the shingles, which are finally discharged through the central aperture. The two cutters moving in the same direction there will be no tendency of the shingle to vibrate, but the rotary motion of both rims will force the shingle against the guide piece M. As the upper rim is free to move up and down it will adapt itself to the varying thickness of the shingle blocks.

I do not wish to limit myself to the precise construction herein specified but to cover all merely formal changes.

What I claim as my invention and desire to secure by Letters Patent is—

Shaving shingles by causing them to pass between the faces of two revolving rims having volute threads cut thereon, and armed with suitable cutters, or plane irons, and one of the said cutter rims being so hung as to be self adapting to the varying thickness of the shingles, substantially as specified, and for the purpose set forth.

JOHN A. BRADSHAW.

Witnesses:

M. G. HOWE,  
A. F. L. NORRIS.