



US006490068B1

(12) **United States Patent**  
**Heflinger et al.**

(10) **Patent No.:** **US 6,490,068 B1**  
(45) **Date of Patent:** **\*Dec. 3, 2002**

(54) **LINEAR ANALOG OPTICAL COMMUNICATION SYSTEM WITH TWO TRANSMITTED BEAMS AND PHASE MODULATION**

6,243,168 B1 \* 6/2001 Heflinger et al. .... 356/484

\* cited by examiner

(75) Inventors: **Donald G. Heflinger**, Torrance, CA (US); **Lee O. Heflinger**, Torrance, CA (US)

*Primary Examiner*—Jason Chan  
*Assistant Examiner*—Agustin Bello  
(74) *Attorney, Agent, or Firm*—Robert W. Keller

(73) Assignee: **TRW Inc.**, Redondo Beach, CA (US)

(57) **ABSTRACT**

(\*) Notice: Subject to any disclaimer, the term of this patent is extended or adjusted under 35 U.S.C. 154(b) by 0 days.

An optical communication system uses a radio frequency (RF) signal for communicating an analog communication signal. It comprises an optical transmitter and receiver. The optical transmitter comprises means for generating a first reference light beam, and means responsive to the analog communication signal to produce a communication light beam having phase modulation corresponding to the analog communication signal. The optical receiver comprises first means responsive to the reference light beam and the RF signal to develop a shifted light beam that is shifted in frequency by the RF frequency, second means to interferometrically combine the communication light beam with the shifted light beam to provide a heterodyne signal including information regarding the state of phase of the communication light beam, third means responsive to said heterodyne signal to produce an electrical signal at the optical beat frequency corresponding to the RF and with a phase corresponding to the state of phase of the communication light beam, and fourth means responsive to the RF signal and the electrical signals to provide an output signal that has a linear correspondence to the state of optical phase of the communication light beam and the analog communication signal. The optical transmitter and optical receiver are also invented.

This patent is subject to a terminal disclaimer.

(21) Appl. No.: **09/285,207**

(22) Filed: **Apr. 1, 1999**

(51) **Int. Cl.**<sup>7</sup> ..... **H04B 10/00**; H04B 10/04; H04B 10/06

(52) **U.S. Cl.** ..... **359/154**; 359/192; 359/156

(58) **Field of Search** ..... 359/162, 183, 359/191, 154, 156, 173, 181, 182, 192; 455/42, 523, 103, 137, 141, 151.2, 205, 259

(56) **References Cited**

**U.S. PATENT DOCUMENTS**

3,600,587 A	*	8/1971	Smith	.....	359/156
3,699,463 A	*	10/1972	Stone	.....	329/300
4,769,853 A	*	9/1988	Goodwin et al.	.....	359/156
6,147,755 A	*	11/2000	Heflinger et al.	.....	356/491

**43 Claims, 3 Drawing Sheets**

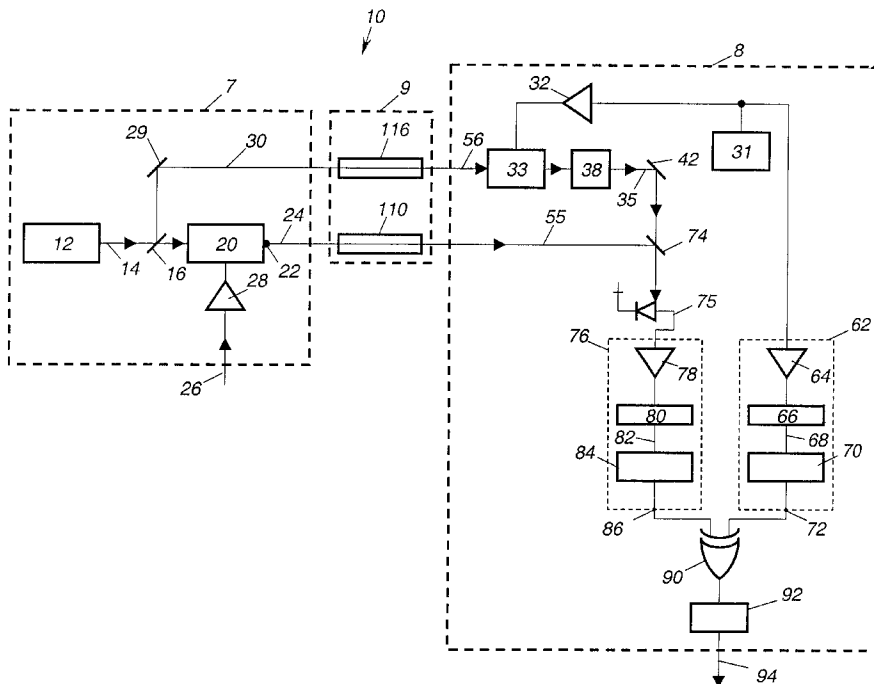

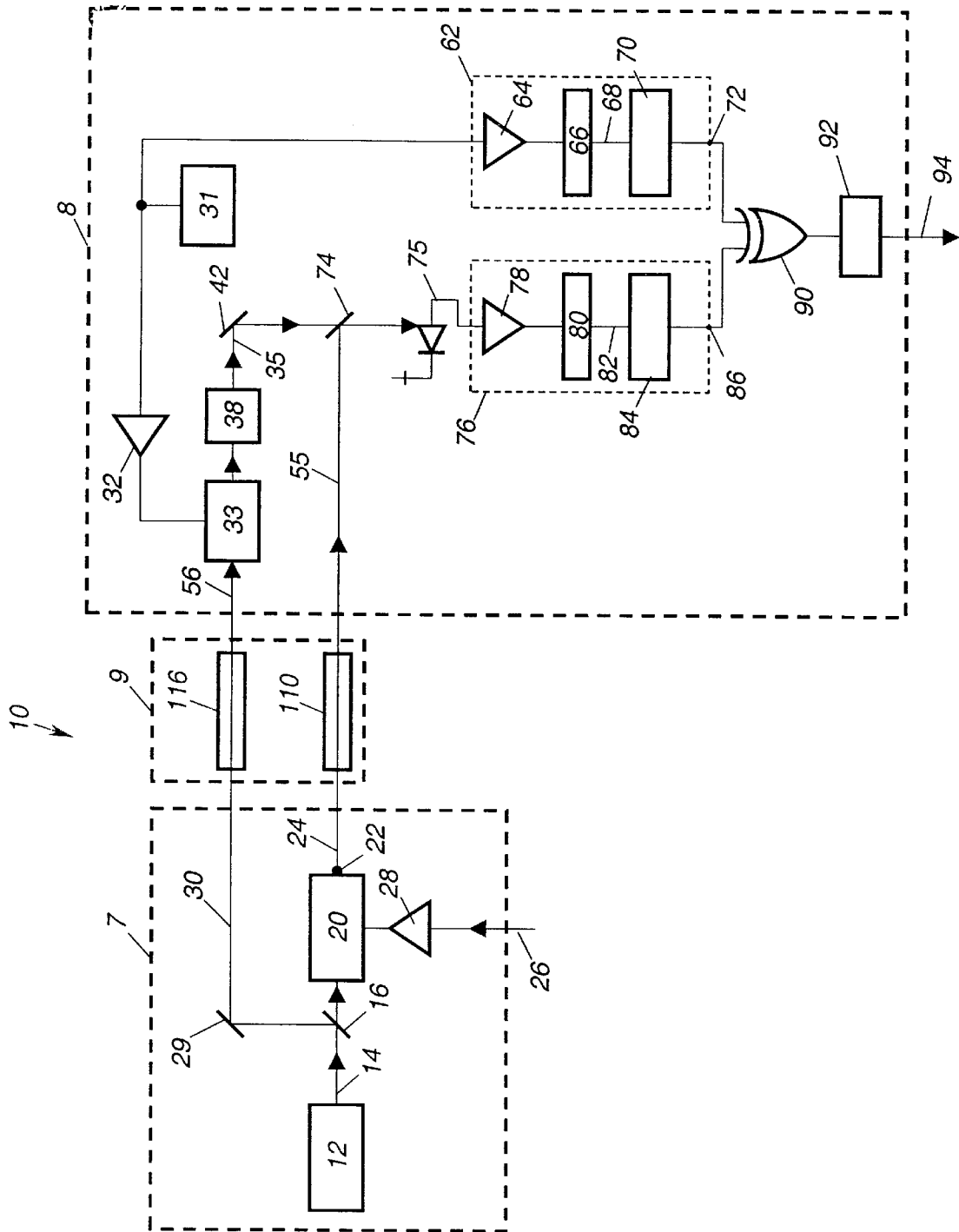

Figure 1.

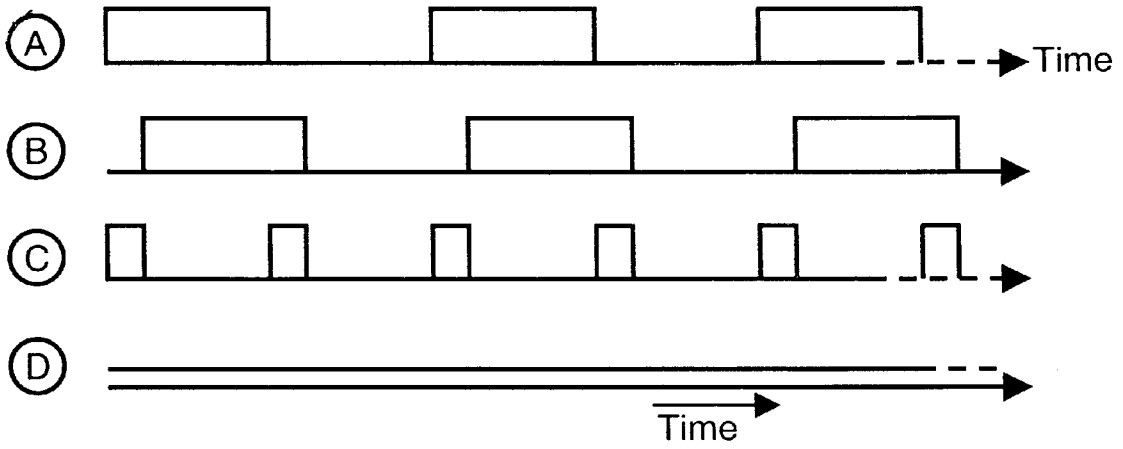

Figure 2.

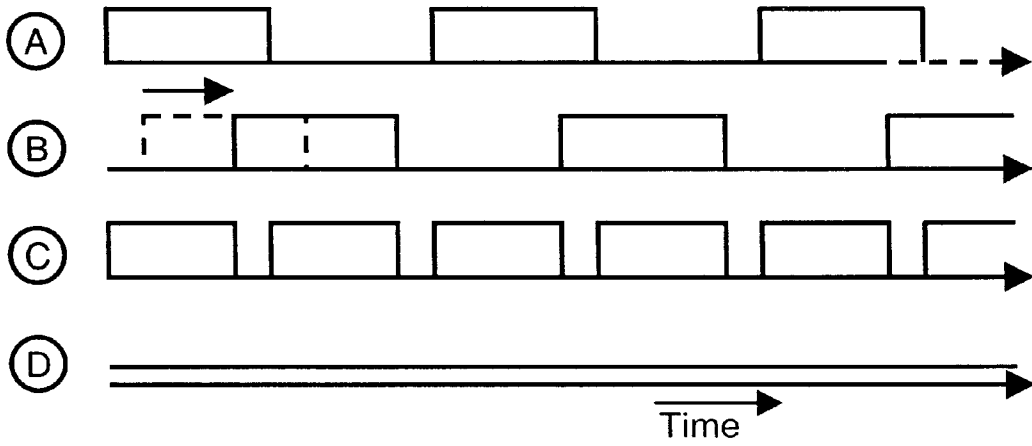

Figure 3.

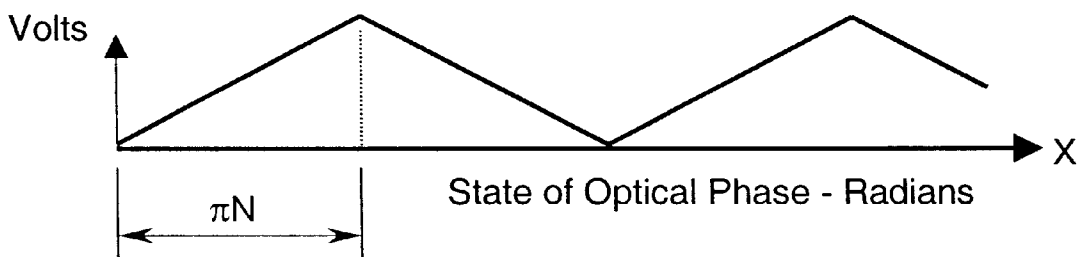

Figure 4.

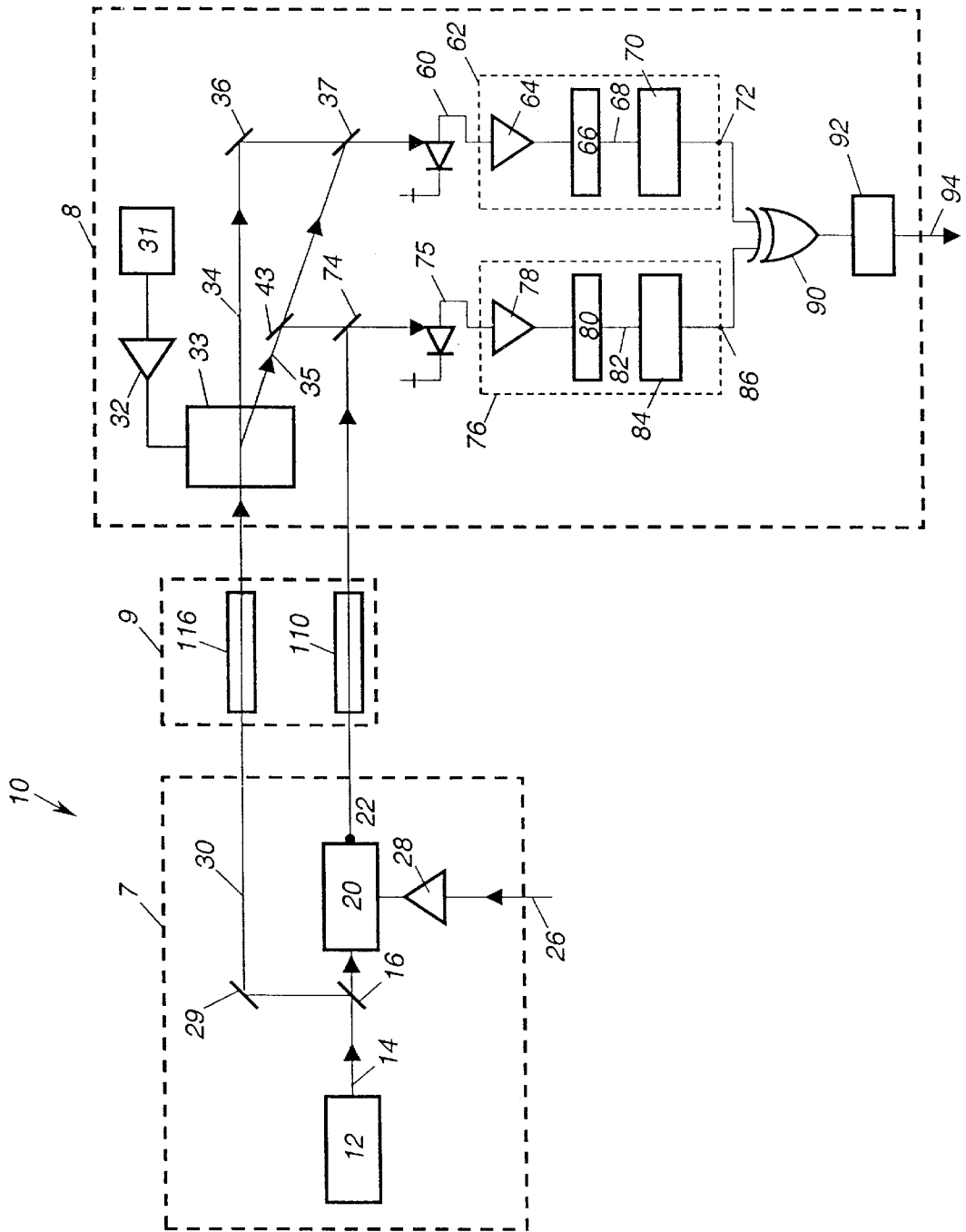

Figure 5.

**LINEAR ANALOG OPTICAL  
COMMUNICATION SYSTEM WITH TWO  
TRANSMITTED BEAMS AND PHASE  
MODULATION**

**CROSS-REFERENCE TO RELATED  
APPLICATIONS**

This application is related to the following commonly assigned applications: "A Dynamic Optical Micrometer", Ser. No. 09/283,484, having inventors Donald Heflinger and Lee Heflinger; "A Dynamic Optical Phase State Detector", Ser. No. 09/282,946, having inventors Donald Heflinger and Lee Heflinger; "Optical Communication System With Phase Modulation", Ser. No. 09/285,215, having inventors Donald Heflinger and Lee Heflinger; and "Optical Communication System With A Single Polarized, Phase Modulated Transmitted Beam", Ser. No. 09/283,053, having inventors Donald Heflinger and Lee Heflinger; filed concurrently with this patent application.

**BACKGROUND OF THE INVENTION**

**1. Field of the Invention**

The present invention is generally related to optical communication systems, and more particularly to an optical communication system utilizing two transmitted beams and phase modulation that provides substantially linear recovery of an analog communication signal.

**2. Description of the Prior Art**

Analog optical communication links are known in the prior art. Conventional optical analog links employ intensity modulation techniques to convey the analog information on an optical beam of light. Such analog optical links are utilized by the cable television industry to transmit video images using the conventional RF analog modulation format for television video. Intensity detection at the receiver using conventional photodetectors enables the light intensity to be linearly converted to an analog voltage corresponding to the signal that is to be transmitted by the link. However, inherent to these analog intensity modulation optical links is an acceptance of a non linearity associated with the intensity modulators used in the transmitter. Mach-Zehnder intensity modulators, which are commonly employed in optical intensity modulation analog links, have a non linear transfer function that yields a sinusoidal intensity variation with a linearly changing applied analog modulation voltage. Similarly, electro absorption modulators also yield a non linear intensity variation to a linearly applied analog modulation voltage.

This inherent non linearity associated with intensity modulators has led to a consideration of using optical phase modulation in the transmitter as an alternative to intensity modulation. Optical phase modulators that can achieve a linear change in the state of the optical phase with a linearly changing analog modulation voltage are known in the art. Modulators can be made from electro optic materials that change their refractive index linearly with applied electric field supplied by a linearly changing analog modulation voltage. The linearly changing refractive index causes the optical path length through the modulator to linearly change. This linearly changing optical path length causes a linearly changing state of optical phase corresponding with a linearly changing analog modulation voltage. Thus, an optical phase modulator can be used in the transmitter to deliver a linearly varying optical signal in contrast to the inherent non linearity associated with intensity modulators.

The utilization of a linear phase modulator in an analog optical communication link requires that the state of optical phase be detected at the receiver. Conventional approaches for this utilize optical interference techniques that cause the phase varying light to become detectable with photodetectors as intensity variations. A common approach used for optical phase state detection is to interfere the phase modulated communication light with an unmodulated reference beam of light that has been split from the initial light source prior to applying the phase modulation. The process of utilizing optical interference techniques to detect the state of optical phase leads to a non linear sinusoidal intensity variation that corresponds to the linearly varying state of optical phase. Thus, this conventional phase detection process leads to a non linearity in the detected analog signal. This non linearity inherent in the conventional phase detection process negates the linearity achieved by the phase modulator and results in an analog optical communication link that is as non linear as the conventional intensity modulation analog optical link. Thus, all analog optical communication links are degraded in performance by an inherent non linearity that distorts the original analog signal that is to be conveyed.

What is needed, therefore, is an analog optical communications system that is capable of detecting the state of optical phase of a phase modulated communication signal in a way so as to produce an analog voltage signal that is linearly related to the state of optical phase of the phase modulated optical signal. Such an analog optical communications system thus will be capable of conveying an analog signal without any non linear distortion.

**SUMMARY OF THE INVENTION**

The preceding and other shortcomings of the prior art are addressed and overcome by the present invention which provides generally a linear optical communication system for communicating an analog communication signal.

Briefly, the linear analog optical communication system comprises an optical transmitter and an optical receiver separated by an analog optical link. The transmitter comprises means for generating a reference light beam and means responsive to the analog communication signal to generate a phase modulated communication beam.

The receiver comprises means responsive to the transmitted reference light beam and an RF signal and operative to develop a shifted light beam that is shifted by the RF frequency, means responsive to the communication light beam and the shifted light beam and operative to interferometrically combine the communication light beam with the shifted light beam to provide a heterodyne signal including information regarding the state of phase of the communication light beam, means responsive to the heterodyne signal and operative to produce an electrical signal at the optical beat frequency corresponding to the RF and with a phase corresponding to the state of phase of the communication light beam, and means responsive to the RF signal and the electrical signal and operative to provide an output signal that has a linear correspondence to the state of optical phase of the communication light beam and the analog communication signal.

More particularly, the detection of the relative phase of the electrical signal includes means for converting the RF signal into a first digital waveform, a first digital divider for dividing the first digital waveform by a predetermined integer to form a first square wave, means for converting the electrical signal into a second digital waveform, a second

digital divider for dividing the second digital waveform by the same predetermined integer to form a second square wave, an exclusive OR circuit for processing the first and the second divided square waves to form a pulse waveform, and means for integrating the pulse waveform to provide the output signal having a magnitude that varies linearly relative to the state of optical phase of the communication light beam and the analog communication signal.

Other aspects of the invention separately describe the transmitter and the receiver.

The foregoing and additional features and advantages of this invention will become apparent from the detailed description and accompanying drawing figures below. In the figures and the written description, numerals indicate the various elements of the invention, like numerals referring to like elements throughout both the drawing figures and the written description.

### BRIEF DESCRIPTION OF THE DRAWINGS

FIG. 1 is a schematic block diagram of the optical communication system in accordance with the present invention.

FIG. 2 is a timing diagram illustrating the waveforms developed at several elements in the receiver of the optical communication system illustrated in FIG. 1.

FIG. 3 is a timing diagram illustrating the waveforms developed at several elements in the receiver of the optical communication system after the state of phase of the pulse modulated signal has been changed.

FIG. 4 is a plot of voltage versus state of optical phase representing the output signal produced by the optical receiver.

FIG. 5 is a schematic block diagram of an alternative embodiment of the optical communication system in accordance with the present invention.

### DETAILED DESCRIPTION OF THE PREFERRED EMBODIMENTS

As illustrated in the schematic block diagram of FIG. 1, the present invention provides a linear analog optical communication system, generally designated by the numeral 10, including an optical transmitter 7 and an optical receiver 8 separated by an analog optical link 9. As will be described the linear analog optical communication system 10 utilizes two transmitted light beams and generates a voltage signal that linearly corresponds to the state of the phase of the phase modulated communication light beam, which in turn corresponds to the voltage of an analog communication signal. The dynamic state of the phase modulated light beam is also referred to as a particular wavefront state. The particular embodiment shown in FIG. 1 uses free-space optical interconnections, however, as will be described, an all fiber optic embodiment is also possible.

In the optical transmitter 7, an optical source 12 generates a beam of coherent light at an optical frequency  $\nu$ , which is applied on an optical fiber or a free-space beam 14 to a beam splitter or fiber optic coupler 16. Preferably, the optical source 12 is a semiconductor laser diode such as a distributed feedback (DFB) laser, although any coherent source such as a helium neon (HeNe) laser can also be used.

The beam splitter or fiber coupler 16 sends a portion of the optical source beam into a first input port of a straight optical phase modulator 20 having an optical output 22. An analog communication voltage signal 26, such as a signal in the radio frequency (RF) range or a video signal, is amplified by

analog signal driver 28 and applied to the electrical modulation input terminal of the straight optical phase modulator 20.

The straight phase modulator 20 is a linear optical device that comprises an electro-optic medium that has a refractive index that depends linearly on the voltage applied across the medium. Thus, the refractive index of the optical medium is dynamically changed according to the applied voltage signal. When the refractive index of the optical medium is changed, the "optical path length" is changed and this causes a change in the relative optical phase of the light delivered by the straight phase modulator (relative optical phase refers to the state of the phase at the output when there is an applied voltage compared to the state of the phase at the output when there is no applied voltage). Accordingly, the straight phase modulator 20 effects the state of the optical phase of the light delivered at output 22 so as to have a linear dependence with the applied voltage. By changing the optical path length it produces a phase modulated communication beam 24 that corresponds linearly with the analog communication voltage signal that is applied at 26.

In this patent the phrase "optical path length" is characterized and mathematically defined as the product of the physical propagation distance and the associated refractive index of the medium through which the light propagates. It should be recognized that adjusting the optical path length can be accomplished by adjusting the physical propagation distance or adjusting the index of refraction of the medium.

The remaining portion of the optical source beam is sent by beam splitter or fiber optic coupler 16 to optical path 30 by either fiber or reflector 29 which is preferably an approximately 45° mirror and reflects the optical signal. This light is now referred to as the reference light beam 30 and is delivered out of the transmitter 7 and through one of the two beams of the analog optical link 9. The other transmitted beam is the phase modulated communication beam 24. These two light beams must remain separated, either by having independent non overlapping free-space paths or by each being carried by a separate optical fiber. In the preferred embodiment, the light beams 30 and 24 transmitted by the transmitter 7 through the analog optical link 9 are carried by separate optical fibers.

The receiver 8 receives the light beams 55 and 56 after they pass through the analog optical link 9. In the receiver 8, a radio frequency (RF) oscillator 31 generates an RF fixed frequency electrical signal which is applied through an amplifier or RF driver 32 to an optical frequency shifter 33. The optical frequency shifter 33 is positioned to receive the reference light beam 56 and serves to shift the optical frequency of the beam 56 by an amount corresponding to the RF. In the preferred embodiment, the optical frequency shifter 33 is an optical modulator such as a Mach-Zehnder modulator followed by a narrow pass band optical filter to extract the shifted side band light, but it can be an acousto-optic modulator.

In the case of using a Mach-Zehnder modulator as an optical frequency shifter 33, the modulator is biased at the minimum light transmission so that the delivered light will be directed into just the upper and lower side bands at an optical frequency that is shifted either up or down by the RF. By filtering this light with a narrow pass band optical filter 38, such as a Fabry Perot filter or a Bragg grating filter, it is possible to extract just the light that is either upshifted or down shifted in frequency.

In the case of an acousto-optic modulator, an acoustic sound wave is generated in an optically transparent medium

by a piezoelectric transducer and the applied RF. This sound wave provides a traveling Bragg grating with a period that corresponds the RF and diffracts the incident light into an upshifted and/or down shifted light beam. The first order of diffraction is shifted in optical frequency by the RF, the second order of diffraction is shifted in optical frequency by twice the RF and so on.

The RF drive signal from oscillator **31** must be well above the highest frequency component of the analog communication signal. In the case of an acousto-optic modulator, this RF signal is limited to roughly 2 GHz. For the Mach-Zehnder modulator this RF signal can be as high as 40 GHz. It should be recognized that any fixed RF frequency can be used as long as it is higher in frequency than the highest analog frequencies in the communication signal.

The RF drive signal from oscillator **31** is also sent to the divide chain **62**. An amplifier **64** amplifies the RF drive signal to a sinusoid at a preselected amplitude that can trigger a digitizing circuit. More particularly, a Schmidt trigger **66** converts the sinusoid into a digital waveform at the RF drive signal frequency. However, other components that are functionally equivalent to a Schmidt trigger and that yield a signal that can be sent to a digital divider also can be used.

The digital waveform signal at **68** is then provided to a digital divider **70** that creates at its output **72** a square wave that is lower in frequency by the particular integer divisor used in the divide chain. Simple digital flip-flop dividers make it convenient to divide by a particular power of two. Mathematically, the square wave frequency is:

$$f/2^m, \text{ where } m=1,2,3,4 \dots,$$

and  $f$  is the RF drive signal frequency. The power of two used for the division depends on the desired resolution of the phase. It will be apparent that division by integers, denoted as  $N$ , other than powers of two also will result in similar performance provided the output of the divider chain is a square wave and that both chains **62** and **76** divide identically. Division by powers of two is the preferred embodiment because of its simplicity and ease of implementation.

The upshifted light **35** that has been frequency shifted by optical frequency shifter **33** and filtered by narrow pass band optical filter **38** is conveyed by optical fiber or mirror **42** to beam combiner **74**. Beam combiner **74** can be a 50—50 beam splitter or a fiber optic coupler. Similarly, the phase modulated communication beam **55** is applied to the beam combiner **74**. The beam combiner **74** interferometrically combines the beams and applies the results to photodetector **75**. The beam combiner **74** combines the light from the frequency upshifted and the phase modulated communication beams so that the optical interference between the beams performs an optical heterodyne that generates the beat frequency representative of the RF drive signal from oscillator **31**. Preferably, the optical path length of the two beams are equal. The beam splitter achieves this optical interference by making the two beams co-linear and superimposed on each other, but other techniques, including fiber optic combining techniques can be used.

The photodetector **75** responds to the intensity variation in the interference of the combined beams by optically heterodyning the two optical frequencies to create the RF beat frequency signal. This is applied to path **76** as shown in dashed lines. The particular state of phase of the detected RF beat frequency relative to the original RF driver signal from oscillator **31** corresponds directly to the particular state of phase of the phase modulated communication light beam **24**.

An amplifier **78** amplifies the detected RF beat frequency signal to a sinusoid at a preselected amplitude that can trigger a digitizing circuit. More particularly, a Schmidt trigger **80** converts the sinusoid into a digital waveform signal at **82** which corresponds to the RF beat frequency. However, other components that are functionally equivalent to a Schmidt trigger and yield a signal that can be sent to a digital divider also can be used.

The digital signal waveform at **82** is then provided to a digital divider **84** that creates at its output **86** a square wave that is lower in frequency by the particular integer divisor used in the divide chain. Just as was the case in divide chain **62**, simple digital flip-flop dividers make it convenient to divide by a particular power of two. Mathematically, the square wave frequency is:

$$f/2^m, \text{ where } m=1,2,3,4 \dots,$$

and  $f$  is the RF driver signal frequency. The power of two used for the division must be identical to that used in divider **70**. It will be apparent that division by integers, denoted as  $N$ , other than powers of two also will result in similar performance provided the output of the divider chain is a square wave and that both chains **62** and **76** divide identically.

For analog communication signal frequencies less than 1 MHz, the digital dividers **70** and **84** can be fast TTL flip-flops manufactured by Fairchild Corporation and designated as Model 74F74. For higher analog communications signal frequencies, the digital dividers **70** and **84** are made from ECL logic or digital GaAs or InP high speed integrated circuit logic which will enable analog communication signal frequencies up to 2 GHz. The two resulting square waves at **72** and **86** have an offset in their relative phase dependent on the original offset in phase that was created by the straight optical phase modulator **20**.

With reference now to FIG. 2 timing diagrams are shown for the signals appearing at the outputs **72** and **86** as they are processed through successive stages of the optical receiver. More particularly, the offset is shown by the displacement in the transitions in the timing diagram between the signal **72** at FIG. 2A, which is the divided square wave signal derived from the RF drive signal, and the signal **86** at FIG. 2B, which is the divided square wave signal from the phase modulated communication signal beat frequency. As illustrated, one period of the square waves shown in FIGS. 2A and 2B is  $2^m/f$ . When these square wave signals are combined by an exclusive OR gate **90** it produces a pulse wave form shown by the signal at FIG. 2C, with a duty cycle dependent on the changed phase due to the straight optical phase modulator **20**. This duty cycle is then sent through a low pass filter **92** that develops a DC voltage on its output as shown in FIG. 2D, having a magnitude that is dependent on the duty cycle. Preferably, the filter **92** is a conventional resistor capacitor integrator circuit that has a time constant that is less than the time transitions in the analog communication voltage signal applied at **26**.

As shown in FIG. 3, new waveforms are created as a new interference pattern is developed by the optical interferometer. This results in the square wave signal at FIG. 3B being developed by the digital divider **70**. As shown its signal is displaced relative to the signal at FIG. 3A (and also to the signal shown in FIG. 2B as illustrated by the dashed lines) and corresponds to the phase change. This leads to a new pulse wave form at the output of the exclusive OR gate **90** with an increased duty cycle as shown by the signal at FIG. 3C. This increased duty cycle creates a larger DC voltage at the output **94** of the low pass filter **92** as shown in FIG. 3D

that has a linear dependence on the actual phase change. Plotting the voltage at the output **94** as a function of the state of optical phase in radians of the phase modulated communication beam leads to a repeating linear triangular wave form that spans several wavelengths of phase change as shown in FIG. **4**. Note that in FIG. **4** the independent variable is the state of optical phase in radians not time as shown in FIGS. **2** and **3** and that the voltage increases linearly from a minimum to a maximum when the state of optical phase is changed by  $\pi N$  radians. For the special case of division by powers of two this is equal to  $\pi 2^m$  radians, where  $m$  is the integer power of two used in the divide chains. Also note that the linear triangular pattern repeats after the phase has changed by several wavelengths of optical phase. In normal use the division ratio will be chosen so that the multiple wavelength of phase change all takes place on a single slope or segment of the response curve of FIG. **4**, thus giving a linear response without passing over the peaks or valleys of the triangle wave, thereby avoiding ambiguity. Since the state of optical phase in the phase modulated communication beam has a direct linear correspondence to the analog communication signal, the output voltage at **94** will have a direct linear correspondence to the analog communication voltage signal applied at input **26**.

Referring now to FIG. **5**, an alternative embodiment of the linear analog optical communication system **10** is illustrated. Many of the parts of the system **10** are identical in construction to like parts in the system illustrated in FIG. **1** described above, and accordingly, there have been applied to each part of the system in FIG. **5** a reference numeral corresponding to the reference numeral that was applied to the like part of the system described above and shown in FIG. **1**.

The fundamental difference between the system **10** of FIGS. **1** and **5** is that this embodiment shows the application of an acousto optic modulator as a frequency shifter and an optical interference means for obtaining the RF drive signal reference. This type of frequency shifter **33** does not require a narrow band optical filter.

The acousto-optic modulator **33** creates an acoustic sound wave that forms a traveling Bragg grating and generates two optical beams **34** and **35** from the modulated beam of light. The optical beam **34** is denoted as the reference beam and comprises the unshifted zeroth order beam of transmitted coherent light at frequency  $\nu$  that passes directly through the modulator. The optical beam **35** is a first order Bragg diffracted beam that is up shifted in optical frequency by the RF modulation frequency ( $\nu+2$  GHz for the upper frequency limit of an acousto optic modulator) and is directed at the Bragg diffraction angle. Alternatively, both beams can be shifted. In any event, the beam **35** is separated from the beam **34**.

The reference beam **34** is reflected off  $45^\circ$  mirror **36** to a beam combiner **37**. Simultaneously, the upshifted light beam **35** is applied through beam splitter **43** to the beam combiner **37** where it interferometrically combines with the reference beam **34** and is applied to photodetector **60**. The beam combiner **37** combines the light from the frequency upshifted and the frequency unshifted beams so that the optical interference between the beams performs a heterodyne of the two optical frequencies which generates the beat frequency representative of the RF drive signal generated by oscillator **31**. Preferably, the optical path length of the two beams are equal. The beam splitter achieves this optical interference and performs the heterodyne by making the two beams co-linear and superimposed on each other, but other techniques, including fiber optic combining techniques, also can be used.

It should be recognized that the degree of coherence provided by the particular source used dictates the optical path lengths and the particular beam recombination geometry. Thus sources at various wavelengths, optical paths of different lengths and different mirror geometries may be employed. It is important, however, that the light from the two beams be combined so that the optical interference that occurs between the two beams generates the beat frequency corresponding to the RF drive signal frequency from oscillator **31**.

In addition, the acousto-optic modulator **33** can generate other beams that can be used besides the unshifted beam and the upshifted beam shown in FIG. **5**. In particular, it is possible to use a down-shifted beam (not shown) that can be generated by the acousto-optic modulator in place of the upshifted beam or to shift both beams.

The photodetector **60** responds to the intensity variations of the combined beams that are generated by optically heterodyning the two optical frequencies to create the reference RF beat frequency signal. This is applied to divide chain path **62** as shown in dashed lines. The photodetectors in this invention are preferably PIN photodiodes, but other photodetectors such as avalanche photodiodes or photomultiplier tubes can be used.

In this way, the RF drive signal reference is generated using optical interference in this alternative embodiment instead of being provided by a direct connection as was done in the embodiment shown in FIG. **1**. The RF drive signal reference generated from optical interference is used exactly as it was in the embodiment shown in FIG. **1** once it is applied to divide chain path **62**. Beam splitter **43** provides a portion of the upshifted light **35** for use at beam combiner **74**, in a similar manner to mirror **42** in the embodiment of FIG. **1**. Accordingly, the present invention provides a linear voltage signal that represents the optical state of phase of the phase modulated communication light beam.

Obviously, many modifications and variations of the present invention are possible in view of the above teachings. Thus, it is to be understood that, within the scope of the appended claims, the invention may be practiced otherwise than as specifically described above.

What is claimed is:

1. An optical communication system for communicating an analog communication signal comprising:
  - an optical transmitter comprising:
    - means for generating a first reference light beam; and
    - means responsive to the analog communication signal and operative to produce a communication light beam having phase modulation corresponding to the analog communication signal; and
  - an optical receiver comprising:
    - first means responsive to said reference light beam and an RF signal and operative to develop a shifted light beam that is shifted in frequency relative to the frequency of said reference light beam by an amount corresponding to the RF signal;
    - second means responsive to said communication light beam and said shifted light beam and operative to interferometrically combine said communication light beam with said shifted light beam to provide a heterodyne signal including information regarding the state of phase of the communication light beam;
    - third means responsive to said heterodyne signal and operative to produce an electrical signal at the optical beat frequency corresponding to the RF signal and with a phase corresponding to the state of phase of the communication light beam; and

fourth means responsive to said RF signal and said electrical signal and operative to provide an output signal that has a linear correspondence to the state of optical phase of said communication light beam and the analog communication signal.

2. The optical communication system as set forth in claim 1, wherein said output signal has a magnitude that varies linearly relative to the state of optical phase of said communication light beam.

3. The optical communication system as set forth in claim 1, wherein said receiver comprises means for generating the RF signal and optical frequency shifting means responsive to said reference light beam and said RF signal and operative to provide said shifted light beam which is shifted in frequency by an amount corresponding to the RF signal.

4. The optical communication system as set forth in claim 1, wherein said optical receiver comprises means for generating said RF signal.

5. The optical communication system as set forth in claim 3, wherein said optical frequency shifting means comprises an acousto-optic modulator.

6. The optical communication system as set forth in claim 3, wherein said optical frequency shifting means includes a Mach-Zehnder modulator and a narrow pass band optical filter.

7. The optical communication system as set forth in claim 3, wherein said optical frequency shifting means shifts the frequency of said reference light beam.

8. The optical communication system as set forth in claim 1, wherein said means responsive to the analog communication signal comprises a straight optical phase modulator.

9. The optical communication system as set forth in claim 1, wherein said fourth means includes fifth means for converting said RF signal into a first digital waveform, a first digital divider for dividing said first digital waveform by a predetermined integer to form a first square wave, sixth means for converting said electrical signal into a second digital waveform, a second digital divider for dividing said second digital waveform by said same predetermined integer to form a second square wave, seventh means includes an exclusive OR circuit for processing said first and said second divided square waves to form a pulse waveform, and eighth means for integrating said pulse waveform to provide said output signal having a magnitude that varies linearly relative to the state of optical phase of the communication light beam and the analog communication signal.

10. The optical communication system as set forth in claim 9, wherein said exclusive OR circuit provides a pulse waveform having a duty cycle that reflects the relative phase between the divided RF signal and the divided electrical signal and an integrating circuit for developing said output signal.

11. The optical communication system as set forth in claim 1, wherein said output signal has an increasing magnitude over the change in the state of optical phase equal to the product of  $\pi$  radians of phase change and the divisor of the said digital dividers.

12. The optical communication system as set forth in claim 1, wherein said output signal magnitude varies linearly from a minimum to a maximum when the state of optical phase is changed by  $\pi 2^m$  radians, where m is any integer.

13. The optical communication system as set forth in claim 1, wherein said output signal magnitude varies linearly from a minimum to a maximum when the state of optical phase is changed  $\pi N$  radians, where N is an integer.

14. The optical communication system as set forth in claim 1, wherein said fourth means includes means for

generating a pulse waveform having a duty cycle that reflects the relative optical phase state of the analog communication signal.

15. The optical communication system as set forth in claim 14, and further comprising means for filtering said pulse waveform to produce said output signal.

16. An optical receiver for receiving a reference light beam and a communication light beam having phase modulation corresponding to an analog communication signal, comprising:

first means for generating a radio frequency (RF) signal; second means responsive to said reference light beam and said RF signal and operative to develop a shifted light beam that is shifted in frequency from the frequency of the reference light beam by said RF signal; and

third means responsive to said phase modulated communication light beam and said shifted light beam and operative to interferometrically combine said communication light beam with said shifted light beam to provide a heterodyne signal including information regarding the state of phase of the communication light beam;

fourth means responsive to said heterodyne signal and operative to produce an electrical signal at the optical beat frequency corresponding to the RF signal and with a phase corresponding to the state of phase of communication light beam, and

fifth means responsive to said RF signal and said electrical signal and operative to provide an output signal that has a linear correspondence to the state of optical phase of said communication light beam and the analog communication signal.

17. The optical receiver as set forth in claim 16, wherein said output signal has a magnitude that varies linearly relative to the state of optical phase of said communication light beam.

18. The optical receiver as set forth in claim 16, wherein said fifth means includes sixth means for converting said RF signal into a first digital waveform, a first digital divider for dividing said first digital waveform by a predetermined integer to form a first square wave, seventh means for converting said electrical signal into a second digital waveform, a second digital divider for dividing said second digital waveform by said same predetermined integer to form a second square wave, eighth means includes an exclusive OR circuit for processing said first and said second divided square waves to form a pulse waveform, and ninth means for integrating said processed pulsed waveform to provide said output signal having a magnitude that varies linearly relative to the state of optical phase of said communication light beam and the analog communication signal.

19. The optical receiver as set forth in claim 18, wherein said output signal magnitude varies linearly from a minimum to a maximum when the state of optical phase is changed by  $\pi 2^m$  radians, where m is an integer.

20. The optical receiver as set forth in claim 18, wherein said output signal magnitude varies linearly from a minimum to a maximum when the state of optical phase is changed by  $\pi N$  radians, where N is an integer.

21. The optical receiver as set forth in claim 16, wherein said fifth means includes a first digital divider and a second digital divider, said digital dividers serving to divide the RF frequency of said RF signal and said electrical signal by N, where N=1, 2, 3, 4 to form said first and second square waves, and circuit means responsive to the divided RF signal

and the divided electrical signal and operative to produce said output signal.

22. The optical receiver as set forth in claim 16, wherein said fifth means includes a first digital divider and a second digital divider, said digital dividers serving to divide the RF frequency of said RF signal and said electrical signal by  $2^m$ , where m is any integer to form said first and second square waves, and circuit means responsive to the divided RF signal and the divided electrical signal and operative to produce said output signal.

23. The optical receiver as set forth in claim 22, wherein said circuit means includes an exclusive OR circuit for providing a pulse waveform having a duty cycle that reflects the relative phase between the divided RF signal and the divided electrical signal and an integrating circuit for developing said output signal.

24. The optical receiver as set forth in claim 23, wherein said output signal has a magnitude that varies linearly relative to the state of optical phase of said communication light beam.

25. The optical receiver as set forth in claim 18, wherein said output signal has an increasing magnitude over the change in the state of the optical phase equal to the product of  $\pi$  radians of phase change and the divisor of the said digital dividers.

26. The optical receiver as set forth in claim 18, wherein said output signal magnitude varies linearly from a minimum to a maximum when the state of optical phase is changed  $\pi 2^m$  radians, where m is an integer.

27. The optical receiver as set forth in claim 18, wherein said output signal magnitude varies linearly from a minimum to a maximum when the state of optical phase is changed  $\pi N$  radians, where N is an integer.

28. The optical receiver as set forth in claim 18, wherein said fifth means includes means for generating a pulse waveform having a duty cycle that reflects the relative optical phase state of the analog communication signal.

29. The optical receiver as set forth in claim 28, and further comprising means for filtering said pulse waveform to produce said output signal.

30. An optical receiver for receiving a reference light beam and a communication light beam having phase modulation corresponding to an analog communication signal, comprising:

first means for generating a radio frequency (RF) signal; second means responsive to said reference light beam and said RF signal and operative to produce a shifted light beam that is relatively shifted in frequency from the frequency of the reference light beam by said RF signal;

third means responsive to the reference light beam and the shifted light beam and operative to interferometrically combine the reference beam with said shifted light beam to provide a first heterodyne signal;

fourth means responsive to said heterodyne signal and operative to produce a first electrical signal at the optical beat frequency corresponding to the RF signal;

fifth means responsive to said communication light beam and shifted light beam and operative to interferometrically combine said communication light beam with said shifted light beam to provide a second heterodyne signal including information regarding the state of phase of the communication light beam;

sixth means responsive to said second heterodyne signal and operative to produce a second electrical signal at the optical beat frequency corresponding to the RF

signal and with a phase corresponding to the state of phase of the communication light beam; and seventh means responsive to said first and said second electrical signals and operative to provide an output signal that has a linear correspondence to the state of optical phase of said communication light beam and the analog communication signal.

31. The optical receiver as set forth in claim 30, wherein said output signal has a magnitude that varies linearly relative to the state of optical phase of said communication light beam.

32. The optical receiver as set forth in claim 30, wherein said seventh means includes eighth means for converting said first electrical signal into a first digital waveform, a first digital divider for dividing said first digital waveform by a predetermined integer to form a first square wave, ninth means for converting said second electrical signal into a second digital waveform, a second digital divider for dividing said second digital waveform by said same predetermined integer to form a second square wave, and tenth means includes an exclusive OR circuit for processing said first and said second divided square waves to form a pulse waveform, and tenth means includes eleventh means for integrating said processed pulse waveform to provide said output signal having a magnitude that varies linearly relative to the state of optical phase of said communication light beam and the analog communication signal.

33. The optical receiver as set forth in claim 30, wherein said output signal magnitude varies linearly from a minimum to a maximum when the state of optical phase is changed by  $\pi 2^m$  radians, where m is an integer.

34. The optical receiver as set forth in claim 30, wherein said output signal magnitude varies linearly from a minimum to a maximum when the state of optical phase is changed  $\pi N$  radians, where N is an integer.

35. The optical receiver as set forth in claim 30, wherein said seventh means includes a first digital divider and a second digital divider, said digital dividers serving to divide the first and second digital waveforms by N, where N=1, 2, 3, 5 to form said first and second square waves, and circuit means responsive to the divided said square waves and operative to produce said pulse waveform.

36. The optical receiver as set forth in claim 30, wherein said seventh means includes a first digital divider and a second digital divider, said digital dividers serving to divide the first and second digital waveforms by  $2^m$ , where m is any integer to form first and second square waves, and circuit means responsive to the divided said square waves and operative to produce said pulse waveform.

37. The optical receiver as set forth in claim 30, wherein said circuit means includes an exclusive OR circuit for providing a pulse waveform having a duty cycle that reflects the relative phase between the divided RF signal and the divided electrical signal and an integrating circuit for developing said output signal.

38. The optical receiver as set forth in claim 30, wherein said output signal has a magnitude that varies linearly relative to the state of optical phase of said communication light beam.

39. The optical receiver as set forth in claim 30, wherein said output signal has an increasing magnitude over the change in the state of the optical phase equal to the product of  $\pi$  radians of phase change and the divisor of the said digital dividers.

40. The optical receiver as set forth in claim 30, wherein said output signal magnitude varies linearly from a minimum to a maximum when the state of optical phase is changed by  $\pi 2^m$  radians, where m is an integer.

**13**

**41.** The optical receiver as set forth in claim **30**, wherein said output signal magnitude varies linearly from a minimum to a maximum when the state of optical phase is changed  $\pi N$  radians, where N is an integer.

**42.** The optical receiver as set forth in claim **30**, wherein said sixth means includes means for generating a pulse waveform having a duty cycle that reflects the relative optical phase state of the analog communication signal.

**14**

**43.** The optical receiver as set forth in claim **30**, and further comprising means for filtering said pulse waveform to produce said output signal.

\* \* \* \* \*