

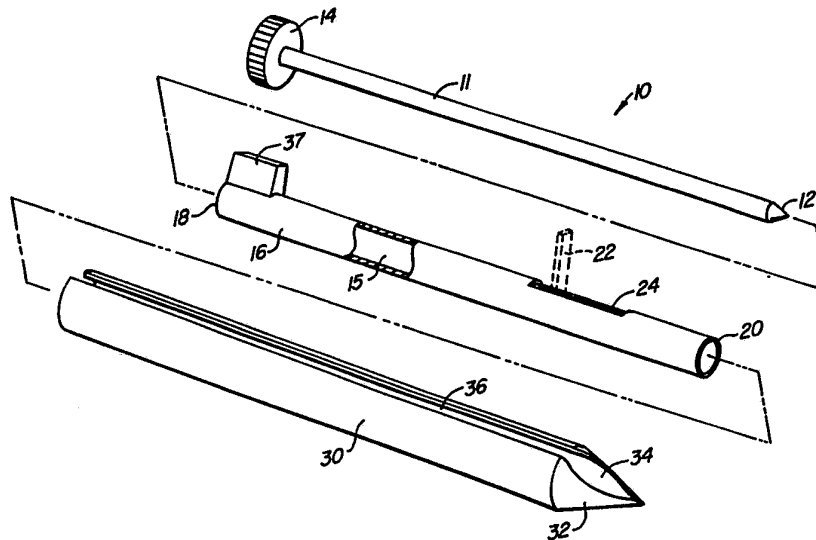

INTERNATIONAL APPLICATION PUBLISHED UNDER THE PATENT COOPERATION TREATY (PCT)

<p>(51) International Patent Classification ⁵ : A61M 29/00</p>	<p>A1</p>	<p>(11) International Publication Number: WO 92/08513 (43) International Publication Date: 29 May 1992 (29.05.92)</p>
<p>(21) International Application Number: PCT/US91/08435 (22) International Filing Date: 12 November 1991 (12.11.91) (30) Priority data: 616,122 20 November 1990 (20.11.90) US (71) Applicant: INTERVENTIONAL THERMODYNAMICS, INC. [US/US]; 2685 Marine Way, Suite 1211, Mountain View, CA 94043 (US). (72) Inventor: BEHL, Robert, S. ; 361 Tioga Court, Palo Alto, CA 94306 (US). (74) Agent: HESLIN, James, M.; Townsend and Townsend, One Market Plaza, 2000 Steuart Tower, San Francisco, CA 94105 (US).</p>		<p>(81) Designated States: AT (European patent), AU, BE (European patent), CA, CH (European patent), DE (European patent), DK (European patent), ES (European patent), FR (European patent), GB (European patent), GR (European patent), IT (European patent), JP, LU (European patent), NL (European patent), SE (European patent). Published <i>With international search report.</i></p>

(54) Title: TENSION GUIDE AND DILATOR



(57) Abstract

A dilator assembly (10) for forming and enlarging percutaneous penetrations into body cavities includes an elongate guide member (20) and one or more elongate dilation members (30). The guide member includes a retractable anchor (22) near its distal end so that an outward force or tension may be maintained on the body cavity wall as successively larger dilators are introduced over the guide member (20). In this way, the alignment of the guide member (20) is maintained along the initial penetration and the tendency for the wall of the body cavity to separate from and invaginate into the surrounding fascia is reduced. Alternatively, means may be provided for internally tensioning or stiffening the guide member so that the guide member will remain aligned and resist withdrawal, buckling, and kinking as a dilator or working catheter is introduced.

FOR THE PURPOSES OF INFORMATION ONLY

Codes used to identify States party to the PCT on the front pages of pamphlets publishing international applications under the PCT.

AT	Austria	ES	Spain	MG	Madagascar
AU	Australia	FI	Finland	ML	Mali
BB	Barbados	FR	France	MN	Mongolia
BE	Belgium	GA	Gabon	MR	Mauritania
BF	Burkina Faso	GB	United Kingdom	MW	Malawi
BG	Bulgaria	GN	Guinea	NL	Netherlands
BJ	Benin	GR	Greece	NO	Norway
BR	Brazil	HU	Hungary	PL	Poland
CA	Canada	IT	Italy	RO	Romania
CF	Central African Republic	JP	Japan	SD	Sudan
CG	Congo	KP	Democratic People's Republic of Korea	SE	Sweden
CH	Switzerland	KR	Republic of Korea	SN	Senegal
CI	Côte d'Ivoire	LI	Liechtenstein	SU ⁺	Soviet Union
CM	Cameroon	LK	Sri Lanka	TD	Chad
CS	Czechoslovakia	LU	Luxembourg	TG	Togo
DE*	Germany	MC	Monaco	US	United States of America
DK	Denmark				

+ Any designation of "SU" has effect in the Russian Federation. It is not yet known whether any such designation has effect in other States of the former Soviet Union.

TENSION GUIDE AND DILATOR
BACKGROUND OF THE INVENTION

1. Field of the Invention

5 The present invention relates generally to
apparatus and methods for providing percutaneous access
into the interior of body cavities. More particularly,
the present invention relates to the construction and use
of an apparatus for introducing one or more dilating
10 members to provide a relatively large penetration to the
hollow body cavity.

 The need to percutaneously penetrate a
patient's skin in order to provide access into the
interior of a hollow body organ arises under a variety of
15 circumstances. For example, various catheters, cannulas,
and the like, may be introduced in order to aspirate the
body cavity, introduce medication into the body cavity,
perform an interventional procedure within the body
cavity, and the like. Numerous devices and methods have
20 been developed in order to provide suitable penetrations
for different procedures.

 One common approach for providing access to the
interior of a body cavity utilizes a trocar and cannula
assembly. The trocar is a metal rod with a sharp tip,
25 while the cannula is a hollow tube which receives the
trocar in its axial lumen. With the trocar in place so
that its sharpened tip extends forward of the cannula,
the assembly can be introduced into the body cavity,
typically through a small puncture hole. The trocar is
30 then removed, and the cannula remains in place with its
lumen providing access to the interior of the body
cavity.

 Such trocar and cannula assemblies have been
used for many years and continue to be adequate for many
35 conventional procedures. A major limitation exists,
however, when it is desired to introduce a relatively
large catheter or other device through the puncture hole

surrounding the cannula. The initial puncture hole is typically small and must be dilated so that larger devices can be introduced. Dilation is typically accomplished by successively introducing one or more
5 dilating rods having increasingly large diameters through the puncture hole and into the hollow organ, typically over a flexible guide wire which has been introduced through the cannula, with the cannula then being removed. Dilating rods typically have a tapered distal end in
10 order to facilitate their introduction and a small central lumen to receive the guide wire. The use of such conventional dilating rods is generally successful when entering cavities which are relatively close to the skin and/or which are restrained from axial movement by their
15 structure or by attachment to surrounding fascia.

The use of dilating rods is less successful with body organs which are not axially constrained, such as the gall bladder, urinary bladder, stomach, and the like, and which have a tendency to move away from and
20 resist entry of even a highly tapered dilating rod. This problem is worsened by the tendency of the flexible guide wire to buckle or bow slightly at the point of entry and for the unconstrained distal of the guide wire to be pulled out of position within the hollow body organ. The
25 resulting misalignment of the guide wire and the entry path formed by the guide wire can exacerbate the problem of dilating the puncture access by causing bowing and invagination of the structure wall and tearing of the body organ away from the surrounding fascia.

30 Various techniques and devices have been developed to at least partly overcome these problems. For example, dilators having very small incremental increases in diameter combined with very gradually tapered distal ends can reduce the incidence of fascial
35 detachment. That approach, however, is not always successful and the need to employ longer, more tapered dilators and/or a greater number of dilators greatly

increases difficulty of manipulating the dilators and/or the time necessary for performing the procedure.

An alternate approach to prevent fascial detachment of the internal body organ has been the use of multiple separate anchors or toggles which are placed peripherally about the site of the primary puncture in order to more strongly attach the body organ to its surrounding fascia. Such an approach is generally workable, but requires a separate puncture for each anchor and subsequent suturing of each anchor in place. Again, such an approach increases patient discomfort as well as the time necessary to perform the procedure.

For these reasons, it would be desirable to provide improved methods and apparatus for forming and enlarging percutaneous penetrations into hollow body organs and cavities. The apparatus and methods should minimize additional time and complexity required for performing any associated interventional procedure, and in particular should avoid the need to make secondary penetrations in order to help secure the body organ to the surrounding fascia. The methods should be suitable for introducing dilators of virtually any diameter, including very large diameters on the order of 20 French, 24 French, and larger while avoiding buckling and misalignment of the dilator guide member. Moreover, the methods and apparatus should be compatible with virtually any type of interventional procedure which requires the formation of a percutaneous penetration for access to the interior of a body cavity.

30 2. Description of the Background Art

U.S. Patent No. 4,772,266, describes a dilator/sheath assembly that may be passed over an indwelling guide wire in order to enlarge an access hole, with entry of the sheath further enlarging the hole.

35 U.S. Patent No. 1,213,001, describes a trocar and cannula assembly which includes an intermediate tube to form a three-piece structure. U.S. Patent No. 3,742,958,

discloses a cannula having an axial slot to allow the cannula to be stripped from a working catheter which has been introduced through the cannula. U.S. Patent Nos. 4,888,000; 4,865,593; 4,581,025; 3,545,443; and 1,248,492, each describe devices suitable for percutaneous penetration of a body cavity, blood vessel, or solid tissue. The disclosures of each of the U.S. Patents cited in this paragraph are hereby incorporated herein by reference. Huibregtse, *Endoscopic Biliary and Pancreatic Drainage*, pages 3-5, (1988) describes the use of a Fogarty balloon catheter to introduce an endoprosthesis through a bile duct stenosis. National-Standard Medical Products, Gainesville, Florida, sells a marking needle with a retractable barb for insertion near a tumor mass, as described in a product description sheet entitled "Hawkins™ Breast Localization Needle."

Methods which rely on the percutaneous introduction of a catheter into the gall bladder and other hollow body organs are described in copending application serial nos. 07/407,839; 07/529,077; and 07/551,971, the disclosures of which are incorporated herein by reference.

SUMMARY OF THE INVENTION

According to the present invention, improved apparatus and procedures for forming and enlarging percutaneous penetrations into hollow body organs and cavities are provided. The apparatus comprises an elongate guide member having proximal and distal ends and means for maintaining the guide member under tension during the enlargement phase of the procedure. Conveniently, the tension means may be a means for anchoring the guide member within the body cavity. Alternatively, the tension means may be a means for controlling the stiffness of the guide means along all or part of its length. The apparatus further comprises one or more elongate dilation members which may be introduced to the body cavity over a path defined by the guide

member. Tension on the guide member is advantageous in at least two respects. First, such tension causes the anchor means to pull outwardly against the inner surface of the body cavity proximate the penetration, reducing the tendency for the organ wall to deform or detach from surrounding fascia as the dilation member(s) are introduced. Second, the tension minimizes the tendency for flexible guide members to buckle or become misaligned as the dilation members are introduced. Such buckling and misalignment can cause the dilation members to deviate from the desired penetration path.

The specific structure of the guide member and the dilator(s) will vary depending on the nature of the organ which is to be accessed. The guide member and/or dilators may be substantially rigid or substantially flexible, depending on the tortuosity of the entry route to the body cavity. For relatively accessible organs which can be approached over a generally straight path, the guide member will usually be rigid and be introduced by means of an integrally sharpened end or an interior stylet in a manner similar to the introduction of a cannula using a trocar. For less accessible organs which require a tortuous approach path, the guide member will usually be flexible in the manner of a flexible guide wire. In either case, the anchor means on the guide member will usually be retractable or collapsible so that the guide member can be inserted (or removed) with the anchor retracted, and the anchor extended only after the distal end of the guide member has reached the interior of the body cavity. A suitable stiffening means may be an internal stiffening wire which is selectively introduced to the guide member to exert tension over the length of the member by application of force on the distal end of the member. The dilator(s) will usually be introduced directly over the guide member, typically using a passage or slot formed axially in the dilator to receive the exterior of the guide member. Alternatively,

a separate rail, track, guide wire, or the like, may be attached to the guide member and the dilators introduced over said separate element.

5 In a first specific embodiment, the guide member is tubular having a central lumen. The anchoring means is a deflectable element which is secured near the distal end of the tubular guide member and which is able to assume a retracted configuration within the lumen or an extended configuration where it projects radially
10 across the lumen and out an aperture formed in the opposite wall of the cylindrical guide member. Usually, the deflectable element is spring-mounted so that it assumes the radially-projecting configuration when unconstrained. In the latter case, a stylet will be
15 slidably disposed within the lumen so that it can move (and maintain) the deflectable element into its retracted configuration. Thus, the assembly of the tubular guide member and stylet can be first introduced in the body cavity, typically with the stylet having a sharpened end
20 to facilitate entry. Once the anchor member is in place, the stylet is removed so that the deflectable element assumes its extended configuration. The guide member can then be pulled outwards or backwards so that the deflectable element is urged against the inner surface of
25 the body cavity and tension maintained on the guide member. While maintaining such tension, a dilator having an axial slot can be introduced over the guide member. The axial slot slidably receives the guide member and is aligned to accommodate the deflectable element as the
30 dilator reaches the distal end of the guide member. The dilator can be removed and replaced by successively larger dilators in a similar manner until a penetration having a desired diameter is formed. Tension will be maintained on the guide member during the entire
35 procedure so that pressure applied by the deflectable element will inhibit detachment of the proximal wall of the body organ or cavity from the surrounding fascia.

Such tension further maintains alignment of the guide member through the initial path of the puncture through the successive layers of tissue and resists buckling of the guide member caused by the applied compressive force of the dilator(s). In this way, the enlarged penetration will be formed along the desired path defined by the initial placement of the guide member.

In an alternate embodiment, the elongate guide member may be a flexible hollow member, such as a flexible catheter or flexible guidewire. The flexible elongate member may be introduced to a desired hollow body organ, either through a penetration, through internal ducts and passages which naturally connect to the hollow body organ, or through a combination thereof. After the flexible elongate member is in place, an internal stiffening member, such as a solid core wire, is introduced through a central lumen of the flexible elongate member so that the distal end of the stiffening member engages the distal end of the flexible elongate member. The stiffening member may then be used to apply tension on to the distal end of the flexible elongate member, thus stiffening the resulting assembly which includes both the flexible elongate member and the internal stiffening member. The stiffened elongate member assembly may then be used in order to introduce a larger dilator and/or working catheter over its exterior in a conventional manner. In this way, a guiding path is defined by the assembly which is much stiffer than that which could be introduced initially, particularly if passing through a tortuous path. The stiffened assembly may provide additional benefits in certain anatomies. For tortuous paths, the stiffened member will tend to straighten the path, frequently reducing the curvature and facilitating the introduction of the catheter/dilator. The stiffened assembly may also tend to imbed or lock itself in place within a restricted

passage further anchoring the member in place as a catheter/dilator is introduced thereover.

In an exemplary method according to the present invention, the flexible guide member assembly just
5 described is introduced to the gall bladder through the duodenum, common bile duct, and cystic duct.

BRIEF DESCRIPTION OF THE DRAWINGS

10 Fig. 1 illustrates a specific dilator assembly constructed in accordance with the principles of the present invention.

Fig. 2 is an elevational view of the guide member and stylet of the dilator assembly of Fig. 1, shown with the guide member in section.

15 Fig. 3 is a front end view of the dilator element of the dilator assembly of Fig. 1.

Fig. 4 is a cross-sectional view of the dilator element shown with the guide member in place.

Fig. 5 is a cross-sectional view taken along line 5-5 of Fig. 4.

20 Fig. 6 is an alternate embodiment of the guide member which can be used with the dilator of Figs. 1-5.

Fig. 7 is a second alternate embodiment of the guide member of the present invention that can be used with the dilator of Figs. 1-5.

25 Figs. 8 and 9 illustrate a third alternate embodiment of the guide member of the present invention that can be used with the dilator of Figs. 1-5.

30 Figs. 10-12 illustrate a method performed in accordance with the principles of the present invention utilizing the dilator assembly of Figs. 1-5.

Fig. 13 illustrates an apparatus constructed in accordance with the principles of the present invention useful for introducing dilators and/or working catheters to hollow body organs through tortuous paths.

35 Fig. 14 is a detailed view of the proximal end of the apparatus of Fig. 13, shown in cross-section.

Fig. 15 is a detailed view of the distal end of the apparatus of Fig. 13, shown in cross-section.

Figs. 16-18 illustrate the use of the apparatus of Figs. 13-15 in introducing a working catheter to the gall bladder in a retrograde manner.

DESCRIPTION OF THE PREFERRED EMBODIMENT

The present invention is useful for forming and dilating percutaneous penetrations into a variety of hollow organ bodies and cavities for a multiplicity of purposes. The sizes of the initial penetrations and subsequent dilations are not critical and may vary widely. The initial penetration will usually be a very small puncture formed using a needle or other small instrument in order to minimize trauma to the patient. Depending on the target organ, the puncture instrument may have a size in the range from about 3 French (F) (where one French equals 0.33 millimeters) to about 8 F, and usually being in the range from about 4 F to 6 F. The initial penetration will typically be dilated to a final diameter from about 10 F to about 30 F, typically being from about 12 F to 28 F and usually being from about 14 F to 24 F, with the present invention being particularly useful for the formation of larger diameter penetrations. The purpose of the penetration can be for drainage, intraorgan drug administration, feeding, perfusion, aspiration, or the like, but will usually be for the introduction of a relatively large working catheter, such as those intended for interventional procedures. Such interventional procedures include laparoscopy, balloon dilatation of ducts, placement of stents, and the like. Penetrations are particularly suitable for the placement of gastrointestinal feeding tubes as well as for the introduction of thermal ablation catheters, such as those described in co-pending applications serial nos. 07/407,829; 07/529,077; and 07/551,971, previously incorporated herein by reference.

The percutaneous penetrations may be formed into virtually any hollow body organ or cavity, particularly including the gall bladder, stomach, urinary bladder, uterus, kidney, portions of the lung, and the like. The methods and apparatus of the present invention are also useful for providing penetrations into blood vessels and other small hollow body structures and ducts. The latter penetrations will often require a flexible guide member to gain access while the former penetrations can frequently be achieved with a relatively rigid guide member.

A dilation assembly according to the present invention includes an elongate guide member which defines a path for the introduction of one or more dilation members into the body cavity. The guide member will have proximal and distal ends, and may have a generally flexible or rigid structure, depending on the particular application. Rigid guide members will generally be employed when the target organ may be approached along a substantially straight path, while flexible guide members will normally be used when a tortuous path must be followed. Rigid guide members may be formed from metals, typically stainless steel, rigid plastics, and the like, while flexible guide members will typically be formed from coiled stainless steel or Nitinol™ wire or from extruded organic polymers, such as silicone rubber, polyurethane, polyvinylchloride, nylon, and the like. In the latter case, reinforcement may be provided in order to provide a particular degree of flexibility suitable for the intended application.

The length of the guide member will vary, with shorter guide members having length in the range from about 10 to 20 cm being suitable for accessing body cavities which are near the surface of the skin, such as the stomach. Longer guide members having a length in the range from about 20 to 40 cm will be suitable for body cavities, such as the kidney. Even longer flexible

members in the nature of a guide wire may be employed for inserting dilating members to blood vessels and other remote ducts. In such cases, the length of the guide wire may be in the range from about 40 cm to 150 cm, or longer.

Generally, the shorter guide members which are used for accessing less remote body organs along a straight path will have a generally rigid structure, while longer guide members intended for accessing more remote body organs and ducts along a tortuous path will have a flexible structure. This correlation, however, will not always be the case, and it may frequently be desirable to utilize a flexible guide member to access hollow body organs along short, straight access paths.

The guide member may have a solid cross-section, i.e. in the form of a solid rod or wire, but more usually will be tubular having a central or axial lumen therethrough. The axial lumen allows the guide member to be introduced using a stylet (as described in more detail hereinbelow) or in the case of flexible guide members, to be introduced over a movable guide wire in a conventional manner. In some cases, of course, the guide member itself may be in the nature of a guide wire, e.g., being formed from nested coils in a known manner.

Means for maintaining the guide member under tension will be provided in combination with the guide member. Usually, the tension means will comprise an anchor means located near the distal end of the guide member, whereby the distal end may be secured within the hollow body organ or other remote location and tension may be applied by pulling outwardly on the proximal end of the guide member which remains external to the patient. Other tension means, however, may also find use. For example, a separate elongate stiffening member may be inserted coaxially within or outside of the guide member in order to provide a desired tension thereon. Alternatively, the tension means may comprise means for

internally pressurizing the guide member in order to provide the desired elongating tension. Other approaches for tensioning the guide member will be obvious to those skilled in the art in view of the teachings herein.

5 Means for anchoring the guide member within the hollow body organ will provided at or near the distal end of the guide member. The anchoring means will be typically retractable or collapsible so that the guide member can be introduced and withdrawn without
10 interference from the anchor. The anchor means is selectively extended or expanded outward from the guide member so that it can engage a structure within the hollow body organ or a nearby region. Tension is then applied by pulling or drawing outwardly on the guide
15 member. In a situation where the guide member penetrates a body cavity, the anchor will usually engage a region of the inner surface of the body cavity proximate the penetration. By thus maintaining a constant tension on the anchoring means, the wall of the body cavity can be
20 held in place and prevented from detaching from the proximal and surrounding fascia during subsequent dilation procedures.

 The structure of the anchoring means is not critical. For example, the anchoring means may be an
25 inflatable balloon which, when in place within a restricted region of the body organ or adjacent duct, may be inflated to become lodged therein. Alternatively, the anchor may be a portion of a flexible guide member, where the portion may be stiffened so that it will become
30 lodged within a tortuous region of a duct or hollow organ to prevent withdrawal of the guide member. Conveniently, the anchor can be a deflectable element which is actuated mechanically, such as using a cable or other actuation means within the guide member. Alternatively, the
35 deflectable element can be formed from a shape memory alloy which is released from a restraining structure or

selectively actuated by a heater which is externally powered.

5 In an exemplary embodiment, the anchoring means is a spring-mounted deflectable finger which is mounted on the inner wall of a tubular or cylindrical guide member. When unconstrained, the finger extends laterally through an aperture in the opposing wall so that it may engage the inner surface of the body organ. Numerous alternative mechanical, electromechanical, and other systems for providing a deflectable element or other anchor means will be apparent to those skilled in the art.

10 The system of the present invention will include one or more dilation members which include a means for following the path defined by the guide member when it extends percutaneously into the hollow body organ. In a preferred embodiment, the system will include a plurality of dilation members which are generally similar in construction, but which have successively larger cross-sectional areas so that the size of the percutaneous penetration can be increased by introducing successively larger dilators over the guide member. Usually, the path following means will be an axial channel formed on one side of the dilator so that it can be passed over the guide member while allowing clearance for the deflectable element. When the dilation member includes an axial channel, it will be desirable to provide keying means near the proximal end of the guide member so that the slot on the axial channel may be radially aligned with the anchor means on the distal end of the guide member. In this way, the slot will necessarily be able to pass the anchoring means, e.g., a radially extending deflectable element, when the dilator reaches the anchoring means. Usually, the dilator will be tapered at its distal end to facilitate penetration, and the dilator may optionally include one or more additional lumens for other purposes, such as the

introduction of a separate movable guide wire which can remain in place after the dilator and guide member are removed from the enlarged penetration. The dilation members will typically have circular cross-sections, although other cross-sectional shapes might also find use.

The size of the dilation members will typically vary from relatively small, i.e. as low as about 10 F, to relatively large, i.e., as large as about 30 F. The incremental increase in size between successfully larger dilators will typically be on the order of about 3 F to 6 F, more usually being about 4 F to 5 F. Thus, it may be necessary to employ as many as about five dilators to form a relatively large penetration on the order of about 30 F. Of course, the permissible incremental increase in the dilator size will depend greatly on the elasticity of the tissue being dilated, the fragility of the attachment of the body organ to the surrounding fascia, and the bearing surface area of the anchor being utilized. Where the tissue elasticity is lower, fascia attachment more fragile, and/or the bearing surface area reduced, the incremental increase in dilator diameter should be smaller.

Referring now to Figs. 1-5, a dilator assembly constructed in accordance with the principles of the present invention includes a stylet 11 having a sharpened distal end 12 and a handle 14 at its proximal end. The stylet 11 is received in an axial lumen 15 of a tubular guide member 16 having a proximal end 18 and distal end 20. A deflectable element 22 is disposed in the lumen 15 having its length generally aligned with the axis of the lumen (when the stylet 11 is in position). An aperture 24 is formed in the wall of the tubular guide member 16 at a location generally opposite to that from the deflectable element 22. The deflectable element is a spring which in its unconstrained configuration (i.e., with the stylet 11 removed from axial lumen 15), assumes

the radially extended position illustrated in broken line in Fig. 2 and in solid line in Fig. 5. With the stylet in place, however, the deflectable element 22 is deflected downward in a retracted position, as illustrated in full line in Fig. 2. In this way, the deflectable element 22 is in its retracted configuration when the assembly of the guide member 16 and stylet 11 is introduced to or withdrawn from the body cavity, as described in more detail hereinafter. The deflectable element 22 may be released into its extended configuration by simply withdrawing the stylet 11 which allows the deflectable element to assume its unconstrained configuration, as illustrated in Fig. 5.

The third component of the dilator assembly 10 is a dilator 30 which is a generally cylindrical tube having a tapered distal end 32 and an axial slot 36. The axial lumen 34 is sized so that it may pass over the exterior of guide member 16, while the slot 34 will be sufficiently large to snap over the guide member. The opening of slot 36 provides clearance so that the dilator 30 may be advanced past the deflectable element 22 when the dilator 30 is introduced into the body cavity, as described hereinafter. Such clearance is best observed in Fig. 4. Keying means, such as tab 37 formed on the distal end of guide member 16 (Figs. 1 and 2), assures that the slot 36 will be properly aligned with the deflectable element 22 as the dilator 30 is advanced forwardly down the guide member. A lumen 40 is optionally provided in the dilator 30, and can be used for introducing a guide wire into the percutaneous penetration after the dilation procedure has been completed. Once passing the guide wire in through the lumen 40, the entire dilator assembly including the dilator 30, guide member 16, and stylet 11 may be removed leaving the guide wire in place.

While only one dilator 30 is illustrated, it will be appreciated that a plurality of dilators having

successively larger diameters may be provided in order to practice the method of the present invention, as described in more detail hereinafter. A particular advantage of the present invention derives from the maintenance of tension on the guide member which results in a compressive force on the tissues which are being penetrated. Such a compressive force tends to hold various layers of the tissue together as the dilator(s) are introduced, allowing the use of larger diameter dilators than would otherwise be possible without tearing or separating tissue layers. Thus, the total number of dilators required to achieve the penetration of a given size may be reduced.

Referring now to Figs. 6-9, construction of several alternative anchoring means will be described. In Fig. 6, a guide member 50 comprises a hollow needle having a sharpened distal tip 52. An aperture 54 in the side of the guide member 50 allows a spring tip 56 of an anchor wire 58 to project outwardly, as illustrated in broken line. Initially, the spring tip 56 is fully doubled-back (as shown in the right hand broken line position), and the spring tip moves out through the aperture as the anchor wire is drawn proximally (to the left in Fig. 6). In this way, the guide member 50 may be introduced through a pre-formed incision and dilator(s) similar to those illustrated in Figs. 1-5, introduced thereover after the spring tip 56 has been released.

The guide member of Fig. 6 can be modified to permit introduction using a removable stylet, similar to stylet 11 in Figs. 1 and 2. In such a modification (not illustrated), sharpened tip 52 would be removed from the shaft, and the distal tip left open. The guide member 50 would then be introduced with the stylet providing the sharpened tip. After placement of the guide member, the stylet would be removed and the anchor wire 58 will be inserted into the lumen of the guide wire. Optionally, the anchor wire could be contained in a loading tube

which maintains the wire in its folded configuration as it is inserted into the guide member.

5 A second alternative anchoring means is illustrated in Fig. 7, where a guide member 60 having an open distal end 62 receives an anchor wire 64 which has an "L" shaped tip when unconstrained. The guide member 60 may be introduced to a hollow body cavity over a separate guide wire, removable hub, or needle in a conventional manner. Conversely, the guide member 60 may be introduced with a sharpened stylet which is subsequently removed. After optionally removing the stylet, guide wire or needle, the anchor wire 64 may be inserted so that a forward spring tip 66 is released from the open distal end 62 and assumes the deflected configuration shown in broken line. Conveniently, the anchor wires 58 (Fig. 6) and 64 (Fig. 7) may be formed from a conventional spring stainless steel or from a high memory alloy, such as Nitinol™. A loader tube which constrains the spring in an appropriate attitude could be used to simplify loading.

10 Referring now to Figs. 8 and 9, a third alternate embodiment for a guide member 70 is illustrated. Guide member 70 includes an outer rigid cannula 72 and an inner segmented rod 74. Rod 74 includes a distal segment 76 having a sharpened distal tip 78, an intermediate segment 80, and a proximal segment 82. The segments 76, 80, and 82, are generally hollow and held together by an elastic member 84 which is secured within the distal segment 76 by a swaged region 86 formed in the distal segment. After the guide member is in place with its distal end within the desired region of the hollow body cavity, the outer cannula 72 may be withdrawn in the proximal direction so that the distal segment 76 and intermediate segment 80 of the inner rod 74 are exposed. In order to collapse the distal structure of the rod 74, tension may be applied to a suture 88 which is secured to the tip of distal segment

76 of the rod member 74. In this way, the distal segment 76 and intermediate segment 80 may be collapsed to the configuration illustrated in Fig. 9. Dilating members (not illustrated) may then be advanced over the outer cannula 70 with the collapsed segments 76 and 80 of the inner rod serving as the anchor means.

Referring now to Figs. 10-12, use of the dilator assembly 10 of Figs. 1-5 for forming a percutaneous penetration through the abdomen A into a stomach S is illustrated. Initially, the assembly 10 including the guide member 16 and stylet 11 is introduced through the abdominal wall A using the sharp protruding end 12 of the stylet to provide access. Optionally, an initial penetration could be made using a needle or other penetrating device. After the guide member 16 has been introduced, the stylet 11 is removed, allowing the deflectable element 22 to assume its extended configuration from guide member 16, as illustrated in Fig. 11. The guide member 16 is then pulled outwardly in the direction of arrow 90 so that the deflectable element 22 engages the inner surface IS of the stomach in the region of the penetration. As illustrated in Fig. 7, placing the guide member 16 under tension pulls the inner wall of the stomach S against the overlying fascia. A first dilation member 30 may then be introduced over the guide member 16 while maintaining tension on the guide member 16, as illustrated in Fig. 8. The number and size of dilators 30 which are finally used will depend on the desired size of the percutaneous penetration. After the desired size is achieved, the tension is released by moving guide member 16 forward to disengage element 22 from the inner surface IS of stomach S. A guide wire may optionally be introduced through a second lumen 40 (Figs. 2-5) that may be incorporated into the larger dilators. The stylet 11 will be reintroduced to the guide member 16 so that the deflectable element 22 is retracted. The dilator 30, guide member 16, and stylet 11 may then be

withdrawn from the penetration, leaving the guide wire in place within a relatively large tract suitable for insertion of a large sheath or working catheter.

5 Referring to Figs. 13-15, an elongate guide member assembly 100 includes an outer flexible tubular assembly 102 and an inner stiffening member 104. The outer flexible tubular member 102 terminates in a threaded receptacle 106 at its proximal end and in a flange element 108 at its distal end. Conveniently, a
10 metallic ring 110 is provided in order to provide a stop member for the inner stiffening member 104, as described in more detail hereinafter.

The nature of the outer flexible tubular member is not critical, and it may be in the form of a hollow
15 polymeric tube, a metallic guidewire, or the like. The tubular member 102, however, should be sufficiently flexible so that it can be introduced through a relatively tortuous passage to a hollow body organ, as will be described with specific reference to retrograde
20 access to the gall bladder hereinafter.

The inner stiffening member 104 terminates at a male thread element 112 at its proximal end, further having a knob attached to facilitate turning. A pin 116 having a rounded head projects from the distal end of the
25 inner stiffening member 104, and the pin 116 and stiffening member 104 together define a shoulder 120, as best observed in Fig. 15. In this way, the inner stiffening member 104 may be inserted into lumen 122 of the flexible tubular member 102 until the shoulder 120
30 engages the stop ring 110. By then tightening down on the threaded member 112 within the housing 106, tension can be applied to the flexible guide member, causing a stiffening of the member along its entire length. Such a stiffened guide assembly 100 provides an excellent path
35 for introducing a working catheter, dilator, or the like to hollow body organ. The stiffened guide member resists buckling, misalignment, and other deformation which might

occur as the working catheter, dilator, or the like is introduced thereover. The stiffened member will additionally tend to straighten the tortuous path, improving access, and can further result in anchoring of the stiffened distal end, particularly when the stiffened end becomes lodged in restricted passages.

Referring now to Figs. 16-18, the introduction of a working catheter to the gall bladder GB through the duodenum D, common bile duct CBD, and cystic duct CD, will be described. The outer flexible tube member 102 is first introduced through the path just described. The high flexibility of the outer flexible tube member 102, along with its small diameter relative to the working catheter WC, allows it to easily pass through the tortuous path which is encountered (Fig. 16). After the outer flexible tubular member 102 has been introduced, the inner stiffening member 104 will be inserted through the lumen 122, and tension will be applied in order to stiffen the resulting assembly 100. As can be seen in Fig. 17, sufficient tension will be applied to generally straighten the resulting assembly 100, particularly through the tortuous cystic duct.

Finally, referring to Fig. 18, a working catheter WC (or flexible slotted dilator) can be introduced over the exterior of the elongate guide member assembly 100 in a conventional manner. The tension provided by inner stiffening member 104 helps maintain the alignment of the guide member assembly 100 while the working catheter WC is being introduced, preventing withdrawal, buckling, kinking, and other deformation of the guide member as the catheter is advanced in the distal direction. Conveniently, the working catheter WC (or equivalent dilator) may include a slotted lumen (not illustrated) along all or part of its length to facilitate introducing the catheter over the guide member assembly 100. Alternatively, the working catheter WC (or dilator) may be pre-loaded on a proximal length of the

guide member assembly 100 while the assembly is introduced and stiffened. The working catheter WC could then be moved forward after the distal end of the guide member assembly 100 is in place.

5 Although the foregoing invention has been described in detail for purposes of clarity of understanding, it will be obvious that certain modifications may be practiced within the scope of the appended claims.

WHAT IS CLAIMED IS:

1. An apparatus for forming a percutaneous penetration into a body cavity, said apparatus
5 comprising:

an elongate guide member having a proximal end, a distal end, means near the distal end for anchoring the guide member against a surface of the body cavity near the penetration; and

10 an elongate dilation member including a tapered distal tip and means for following the guide member into the body cavity.

2. An apparatus as in claim 1, wherein the
15 guide member is rigid.

3. An apparatus as in claim 1, wherein the guide member is flexible.

20 4. An apparatus as in claim 1, wherein the means for anchoring includes a deflectable element having a retracted position substantially within the elongate guide member and an radially projecting position, whereby the guide member may be percutaneously introduced with
25 the deflectable element in its retracted position and anchored against the body cavity surface with the deflectable element in its radially projecting position.

30 5. An apparatus as in claim 4, wherein the deflectable element is a spring or is spring-mounted so that it assumes its radially projecting configuration when unconstrained, said apparatus further comprising means for constraining the deflectable element in its retracted position.

35 6. An apparatus as in claim 5, wherein the elongate guide member includes an axial lumen wherein the

deflectable element is mounted and wherein the means for
constraining the deflectable element comprises a stylet
which is slidably received in the lumen and which engages
the deflectable element to urge said element into its
retracted position.

5

7. An apparatus as in claim 1, comprising at
least two elongate dilation members having different
sizes so that the dilation members may be successively
introduced over the guide member to incrementally enlarge
the percutaneous penetration.

10

8. An apparatus as in claim 4, wherein the
means for following is an axial lumen having an axial
slot for accommodating the deflectable element.

15

9. An apparatus comprising:
a tubular guide member having a proximal end, a
distal end, and an axial lumen therethrough;
a stylet which is slidably received in the
axial lumen of the guide member;
a deflectable element near the distal end of
the guide member, wherein said deflectable element
assumes a retracted configuration when the stylet is in
place and assumes a radially projecting configuration
when the stylet is removed; and
an elongate dilation member having means for
passing over the guide member and clearing the
deflectable element when said element is in its
projecting configuration.

20

25

30

10. An apparatus as in claim 9, wherein the
stylet is sharpened at one end and is sufficiently long
so that said sharpened end will extend beyond the distal
end of the cylindrical guide member when the stylet is in
place within the central lumen, whereby the sharpened end

35

of the stylet facilitates percutaneous penetration into a body cavity.

5 11. An apparatus as in claim 9, wherein the deflectable element is a spring-mounted finger that is retained in an axial orientation when the stylet is in place and assumes a radially projecting configuration when the stylet is removed.

10 12. An apparatus as in claim 11, wherein the tubular guide member has an axially elongate aperture near its distal end and the spring-mounted finger is disposed on the inner lumen wall opposite the aperture so that the finger will project radially outward through the
15 aperture when the stylet is removed.

13. An apparatus as in claim 10, wherein the means for passing the elongate dilator over the guide member includes an axial lumen and slot which slidably
20 receives the guide member while allowing clearance for the deflectable element in its laterally projecting configuration.

14. An apparatus as in claim 10, including at
25 least one additional elongate dilation member having a larger cross-sectional area than the first dilator.

15. An apparatus comprising:
a tubular guide member having a proximal end, a
30 distal end, and an axial lumen therethrough; and
an anchor wire slidably received in the lumen of the tubular guide member, said anchor wire having a spring tip which projects laterally from the guide member when the wire is moved to a preselected axial position
35 within the guide member.

16. An apparatus as in claim 15, wherein the guide member has an aperture in its side wall, wherein the spring tip passes through the aperture where the anchor wire is in its preselected axial position.

5

17. An apparatus as in claim 16, wherein the spring tip is constrained within the guide member in a doubled-back configuration and is released by drawing the anchor wire proximally within the guide member.

10

18. An apparatus as in claim 15, wherein the distal end of the guide member terminates in a sharpened tip.

15

19. An apparatus as in claim 15, wherein the spring tip is constrained within the guide member in an elongated configuration and is released through a distal port on the guide member by extending the anchor wire in the distal direction, whereby the spring tip folds back upon the anchor wire to project laterally.

20

20. A method for forming a percutaneous penetration into a body cavity, said method comprising:
introducing an elongate guide member into the
body cavity through a penetration;
applying tension to the guide member;
advancing a dilation member over the guide member, wherein the tension applied to the guide member inhibits buckling and misalignment of the guide member.

30

21. A method as in claim 20, wherein tension is applied by anchoring the distal end of the guide member and pulling outwardly on the proximal end.

35

22. A method as in claim 20, wherein tension is applied by passing a stiffening member through or over the guide member.

23. A method as in claim 20, wherein tension is applied by internal pressurization of the guide member.

5

24. A method for forming a percutaneous penetration into a body cavity, said method comprising:
introducing an elongate guide member into the body cavity through a penetration;

10

positioning the guide member so that an anchor near its distal end is drawn against a surface of the body cavity near the penetration; and

15

introducing a dilation member over a path defined by the guide member, whereby the diameter of the penetration may be increased.

25. A method as in claim 24, wherein the elongate guide member is introduced with the anchor in a retracted configuration and is positioned by extending the anchor and thereafter drawing the extended anchor against the body cavity surface.

20

26. A method as in claim 25, wherein the guide member is positioned by pulling outward so that the anchor engages the body cavity surface.

25

27. A method as in claim 24, wherein the dilation member is introduced directly over the guide member.

30

28. A method as in claim 24, wherein the dilation member is introduced over a separate track element which is secured to the guide member.

35

29. A method as in claim 24, wherein the guide member is introduced over a guide wire.

30. A method as in claim 24, wherein at least a second dilation member having an increased diameter relative to the first dilation member is introduced over the path defined by the guide member.

5

31. A method for introducing a catheter to a hollow body organ, said method comprising
introducing an elongate guide member through a passage to the interior of the hollow body organ;
10 tensioning the guide member to increase the bending stiffness thereof; and
passing the catheter over the guide member while maintaining the tension.

15

32. A method as in claim 31, further comprising passing at least one additional catheter having a larger cross-sectional size over the guide member while maintaining the tension, whereby the size of the passage may be dilated.

20

33. A method as in claim 31, wherein the guide member is tensioned by inserting a wire core through an axial lumen of the guide member and engaging a distal end of the core against a distal end of the guide member.

25

34. A method as in claim 33, further comprising withdrawing the catheter from the guide member while maintaining the guide member under tension and thereafter introducing a second catheter having a larger
30 cross-sectional area over the guide member while maintaining the guide member under tension, whereby the size of the passage may be increased.

35

35. A method as in claim 31, wherein the hollow body organ is the gallbladder and the passage includes the cystic duct and the common bile duct.

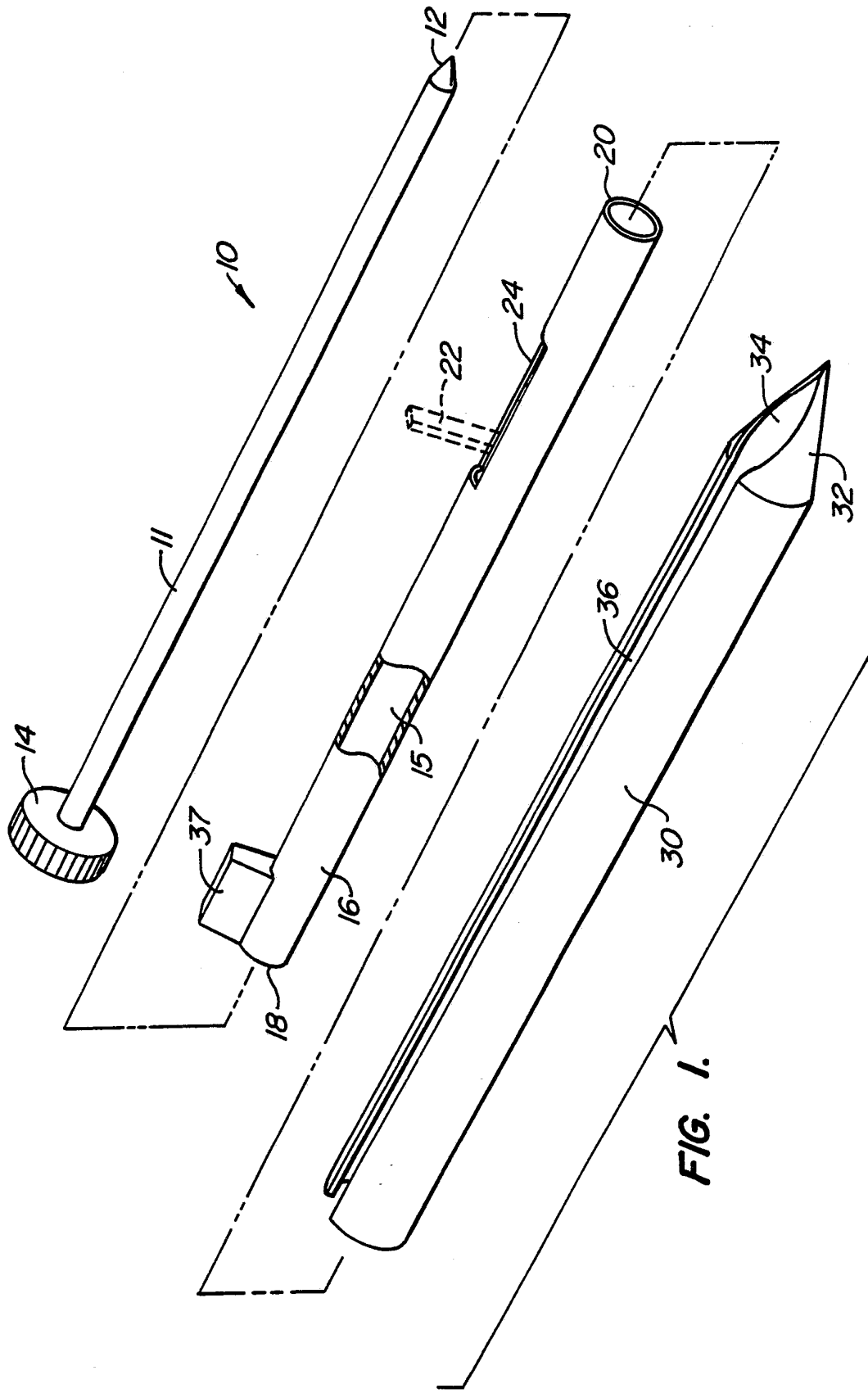

FIG. 1.

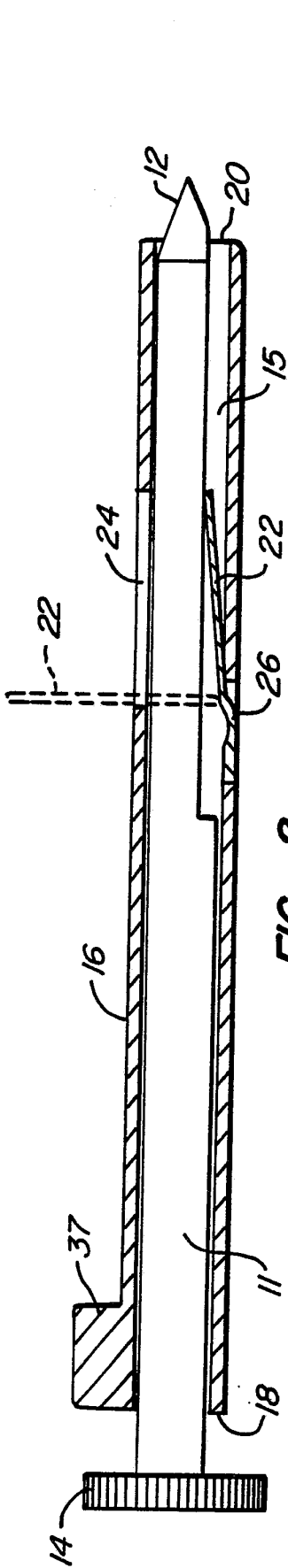

FIG. 2.

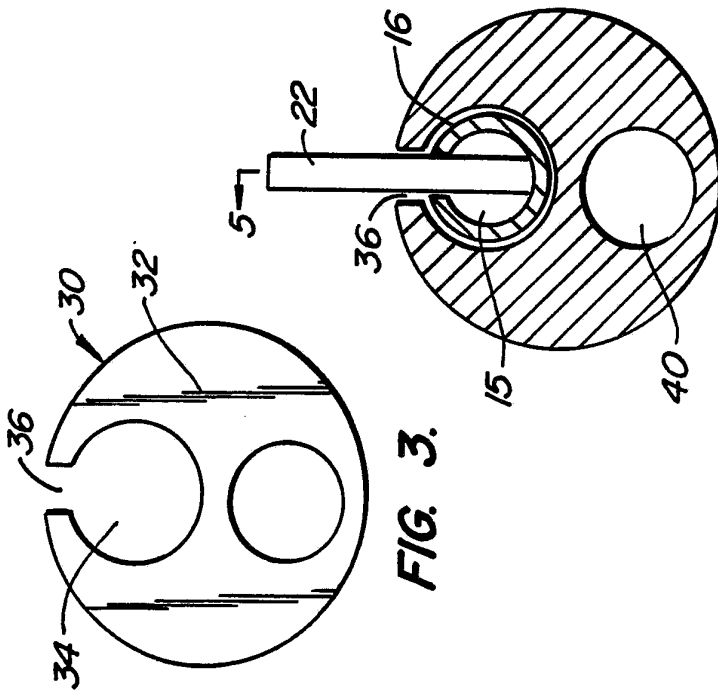

FIG. 3.

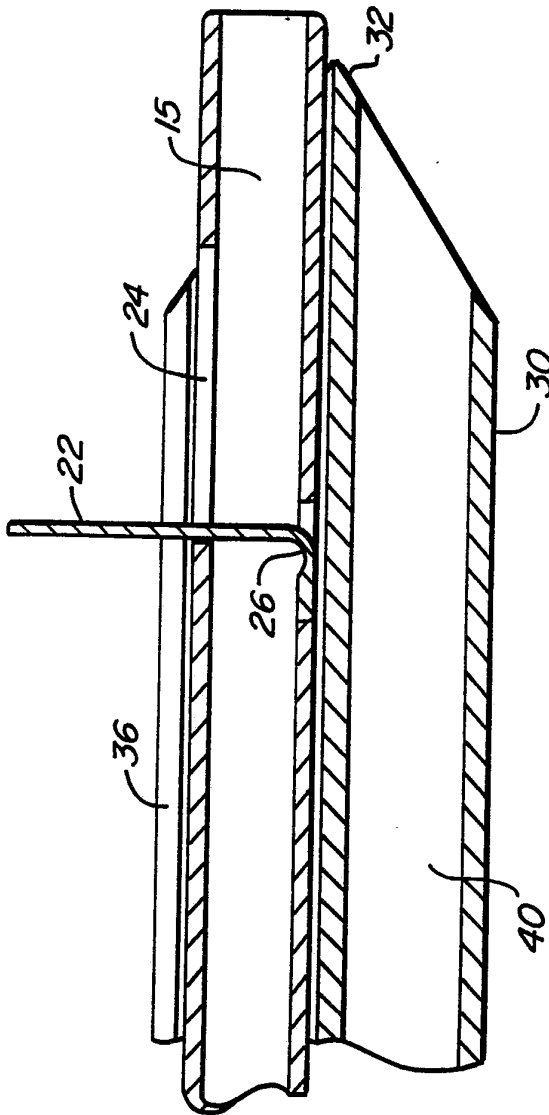

FIG. 5.

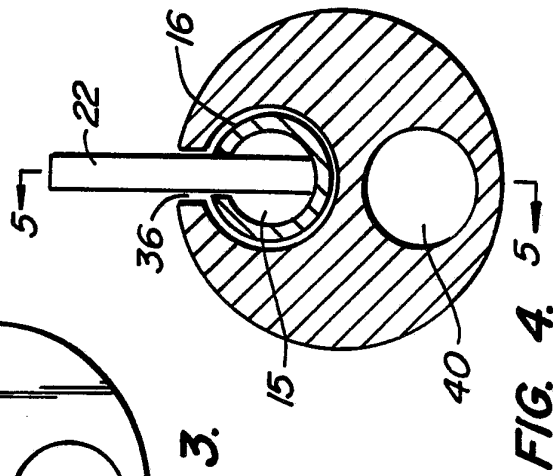

FIG. 4.

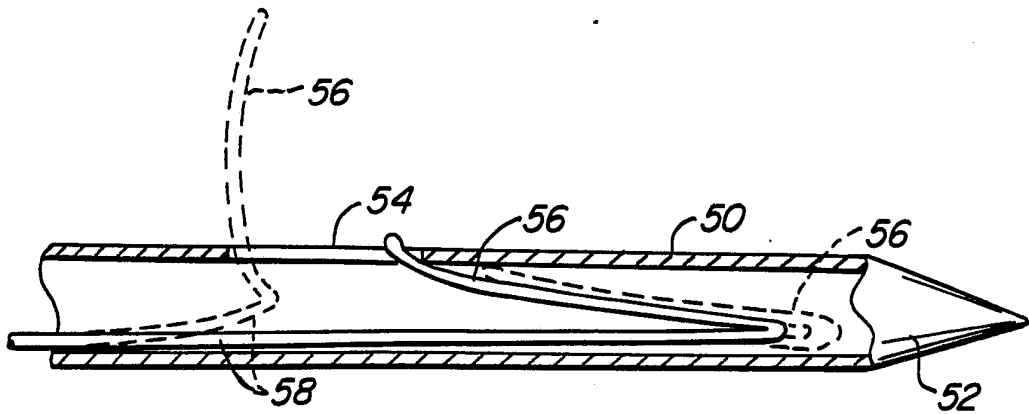

FIG. 6.

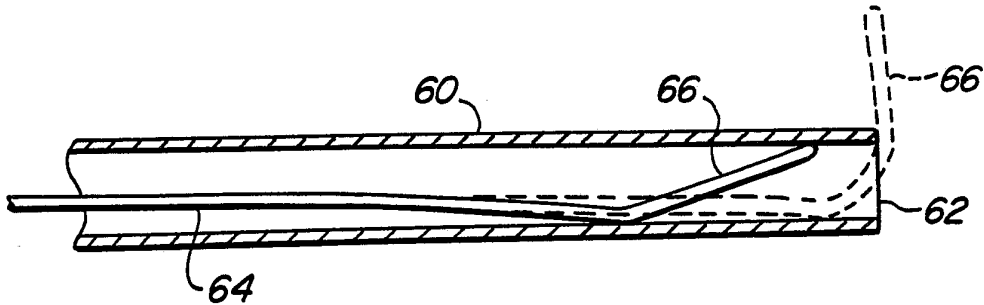

FIG. 7.

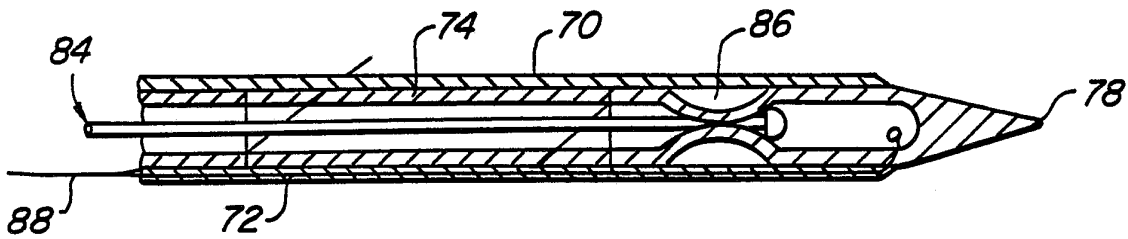

FIG. 8.

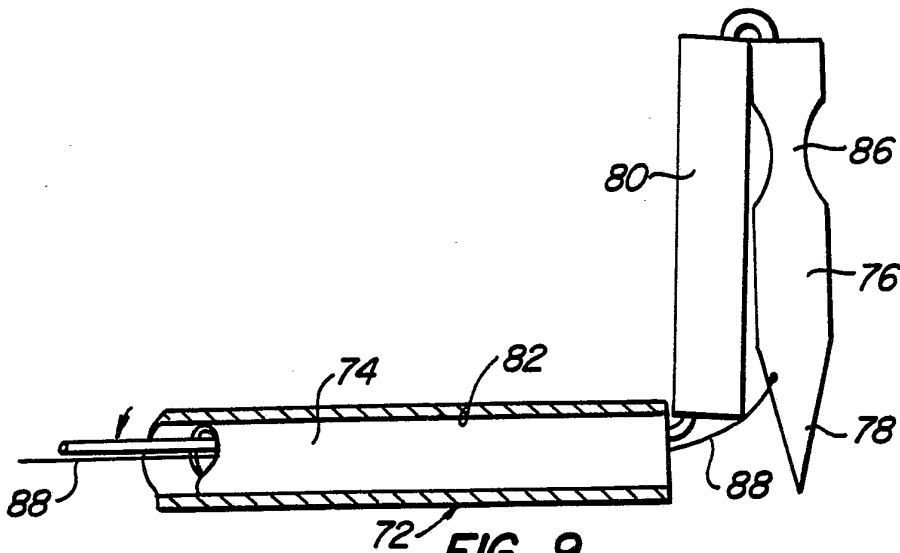

FIG. 9.

SUBSTITUTE SHEET

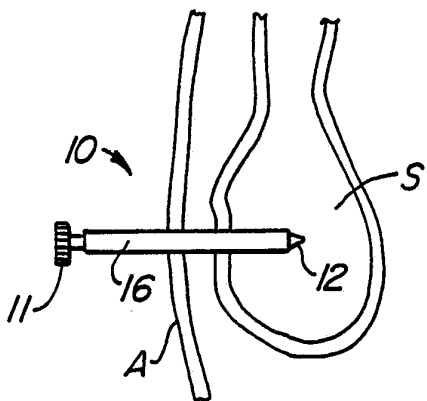

FIG. 10.

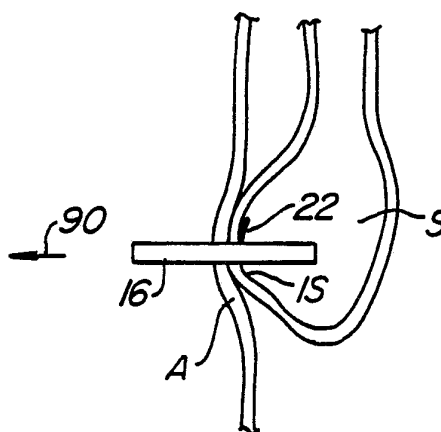

FIG. 11.

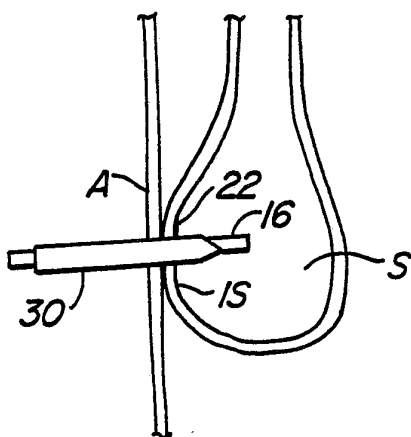

FIG. 12.

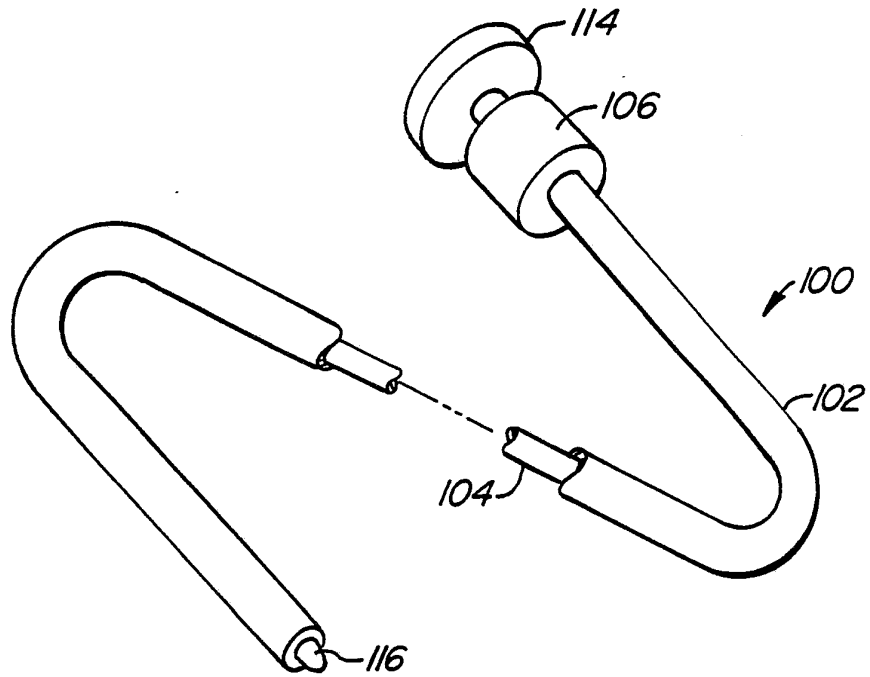

FIG. 13.

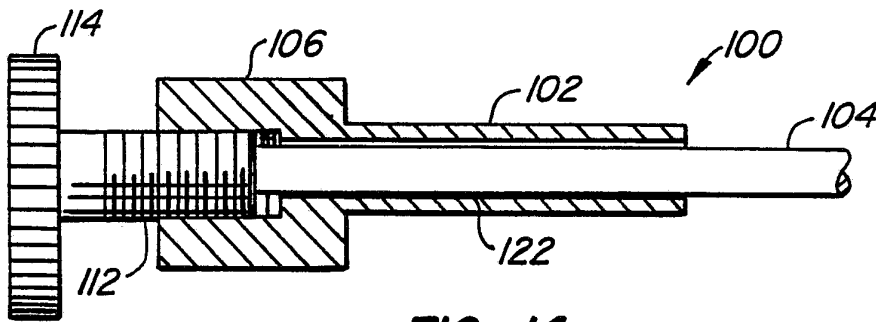

FIG. 14.

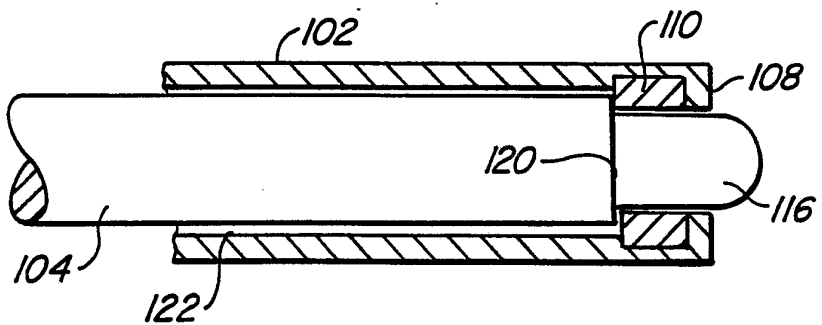

FIG. 15.

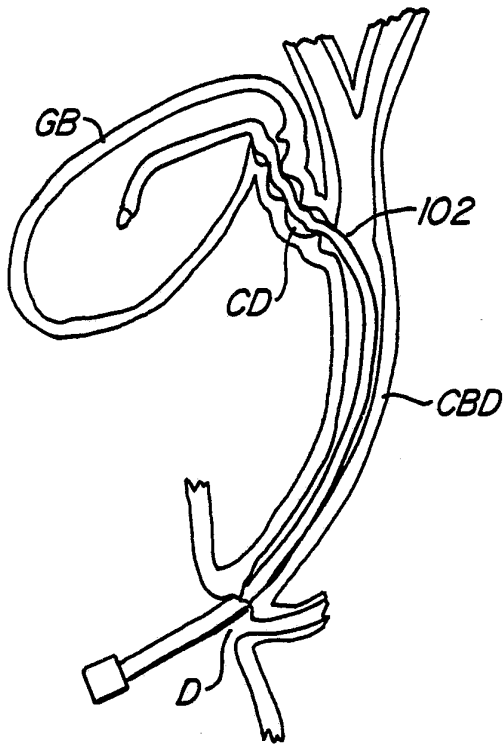

FIG. 16.

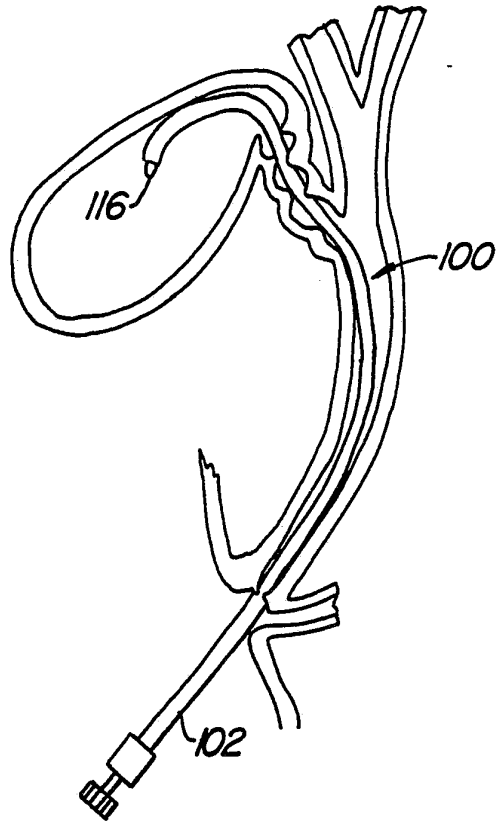

FIG. 17.

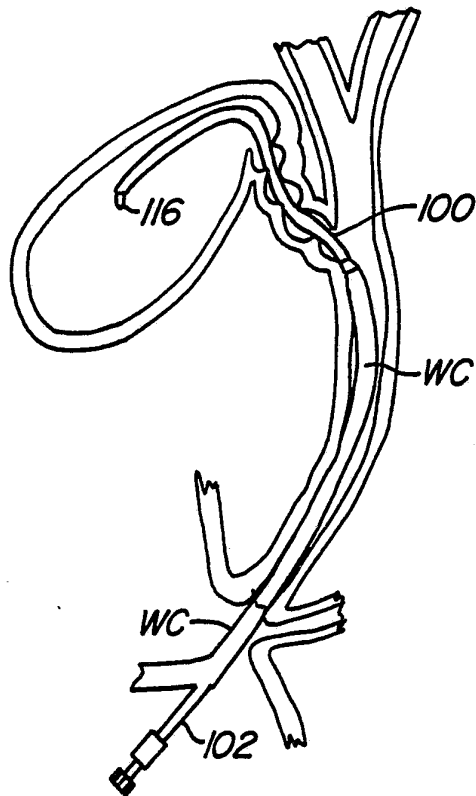

FIG. 18.
SUBSTITUTE SHEET

INTERNATIONAL SEARCH REPORT

International Application No. PCT/US91/08435

I. CLASSIFICATION OF SUBJECT MATTER (if several classification symbols apply, indicate all) ⁶		
According to International Patent Classification (IPC) or to both National Classification and IPC		
U.S. 604/264	IPC(5) A61M 29/00	
II. FIELDS SEARCHED		
Minimum Documentation Searched ⁷		
Classification System	Classification Symbols	
	604/164-166,158-160, 264,174,175,104-106	
US.	606/198	128/657,772
Documentation Searched other than Minimum Documentation to the Extent that such Documents are included in the Fields Searched ⁸		
III. DOCUMENTS CONSIDERED TO BE RELEVANT ⁹		
Category ¹⁰	Citation of Document, ¹¹ with indication, where appropriate, of the relevant passages ¹²	Relevant to Claim No. ¹³
X	US, A, 4,043,346 (MOBLEY ET. AL.) 23 AUGUST 1977 See Fig. 2: guide member (18), anchor (26), dilation member (40) and body cavity(50).	1-5, 8, 15 18,20,21,24-27 31 and 35.
Y	US, A, 4,757,827 (BUCHBINDER) 19 JULY 1988 See stiffening member (3) comprising rigid wire, providing tension to the steerable guide member.	20,23 and 33
Y, P	US, A, 4,994,027 (FARRELL) 19 FEBRUARY 1991 See Figure 2A: teaches successive dilation members of varying diameter.	6,7,9-11,13-15, 17-19, 29,30, 32, and 34.
A	US, A, 4,932,959 (HORZEWSKI) 12 JULY 1990. See entire document.	all
A	US, A, 4,649,916 (FRIMBERGER) 17 MARCH 1987. See entire document.	all
A	US, A, 4,798,593 (IWATSCHENKO) 17 JANUARY 1989 See entire document.	all
A	US, A, 4,844,092 (RYDELL ET. AL.) 4 JULY 1989 See entire document.	all
A	US, A, 4,654,028 (SUMA) 31 MARCH 1987 See entire document.	all
<p>¹⁰ Special categories of cited documents:</p> <p>"A" document defining the general state of the art which is not considered to be of particular relevance</p> <p>"E" earlier document but published on or after the international filing date</p> <p>"L" document which may throw doubts on priority claim(s) or which is cited to establish the publication date of another citation or other special reason (as specified)</p> <p>"O" document referring to an oral disclosure, use, exhibition or other means</p> <p>"P" document published prior to the international filing date but later than the priority date claimed</p> <p>"T" later document published after the international filing date or priority date and not in conflict with the application but cited to understand the principle or theory underlying the invention</p> <p>"X" document of particular relevance: the claimed invention cannot be considered novel or cannot be considered to involve an inventive step</p> <p>"Y" document of particular relevance: the claimed invention cannot be considered to involve an inventive step when the document is combined with one or more other such documents, such combination being obvious to a person skilled in the art.</p> <p>* document member of the same patent family</p>		
IV. CERTIFICATION		
Date of the Actual Completion of the International Search		Date of Mailing of this International Search Report
21 JANUARY 1992		13 FEB 1992
International Searching Authority		Signature of Authorized Officer
ISA/US		NGUYEN HO INTERNATIONAL DIVISION CHALLIN SMITH

FURTHER INFORMATION CONTINUED FROM THE SECOND SHEET

A US, A, 4,737,141 (SPITZ) 12 APRIL 1988
See entire document.

all

V. OBSERVATIONS WHERE CERTAIN CLAIMS WERE FOUND UNSEARCHABLE

This international search report has not been established in respect of certain claims under Article 17(2) (a) for the following reasons.

- 1 Claim numbers _____ because they relate to subject matter not required to be searched by this Authority, namely:
- 2 Claim numbers _____ because they relate to parts of the international application that do not comply with the prescribed requirements to such an extent that no meaningful international search can be carried out¹³, specifically:
- 3 Claim numbers _____ because they are dependent claims not drafted in accordance with the second and third sentences of PCT Rule 6.4(a).

VI. OBSERVATIONS WHERE UNITY OF INVENTION IS LACKING

This International Searching Authority found multiple inventions in this international application as follows:

- 1 As all required additional search fees were timely paid by the applicant, this international search report covers all searchable claims of the international application.
- 2 As only some of the required additional search fees were timely paid by the applicant, this international search report covers only those claims of the international application for which fees were paid, specifically claims:
- 3 No required additional search fees were timely paid by the applicant. Consequently, this international search report is restricted to the invention first mentioned in the claims; it is covered by claim numbers:
- 4 As all searchable claims could be searched without effort justifying an additional fee, the International Searching Authority did not invite payment of any additional fee.

Remarks on Protest:

- The additional search fees were accompanied by applicant's protest.
- No protest accompanied the payment of additional search fees.