



US006957627B1

(12) **United States Patent**
Knippelmeir

(10) **Patent No.:** **US 6,957,627 B1**

(45) **Date of Patent:** **Oct. 25, 2005**

(54) **WATER TRAY DRINKER FOR PIGS**

(76) Inventor: **Bradley W. Knippelmeir**, 611 E. 5th,
Fremont, NE (US) 68025

(*) Notice: Subject to any disclaimer, the term of this
patent is extended or adjusted under 35
U.S.C. 154(b) by 0 days.

(21) Appl. No.: **11/013,947**

(22) Filed: **Dec. 16, 2004**

Related U.S. Application Data

(62) Division of application No. 10/649,245, filed on Aug.
27, 2003, now Pat. No. 6,843,206.

(51) **Int. Cl.⁷** **A01K 7/02**

(52) **U.S. Cl.** **119/77; 119/72**

(58) **Field of Search** **119/72, 74, 77-79,**
119/81, 51.5, 61.2, 61.1

(56) **References Cited**

U.S. PATENT DOCUMENTS

1,227,366 A 5/1917 Bazinet 119/77

2,576,154 A	11/1951	Trautvetter	119/72
2,711,715 A	6/1955	Thale	119/515
4,260,286 A *	4/1981	Buchanan	405/82
4,281,625 A	8/1981	Kasai	119/77
4,824,579 A	4/1989	George	210/703
5,139,364 A *	8/1992	Takahashi et al.	405/81
5,870,970 A *	2/1999	Katz	119/72
6,192,831 B1	2/2001	Brunse	119/51.5
6,588,370 B1 *	7/2003	Odeh	119/219

* cited by examiner

Primary Examiner—Michael J. Carone

Assistant Examiner—Kimberly S. Smith

(74) *Attorney, Agent, or Firm*—Thomte, Mazour &
Niebergall; Dennis L. Thomte

(57) **ABSTRACT**

A water tray drinker for pigs comprising a tray wherein the water compartment thereof is divided into water compartment portions by divider walls of different heights. An adjustable valve water supply mechanism is positioned above the tray for automatically filling one or more of the compartment portions of the tray depending upon the vertical adjustment of the adjustable valve water supply.

2 Claims, 5 Drawing Sheets

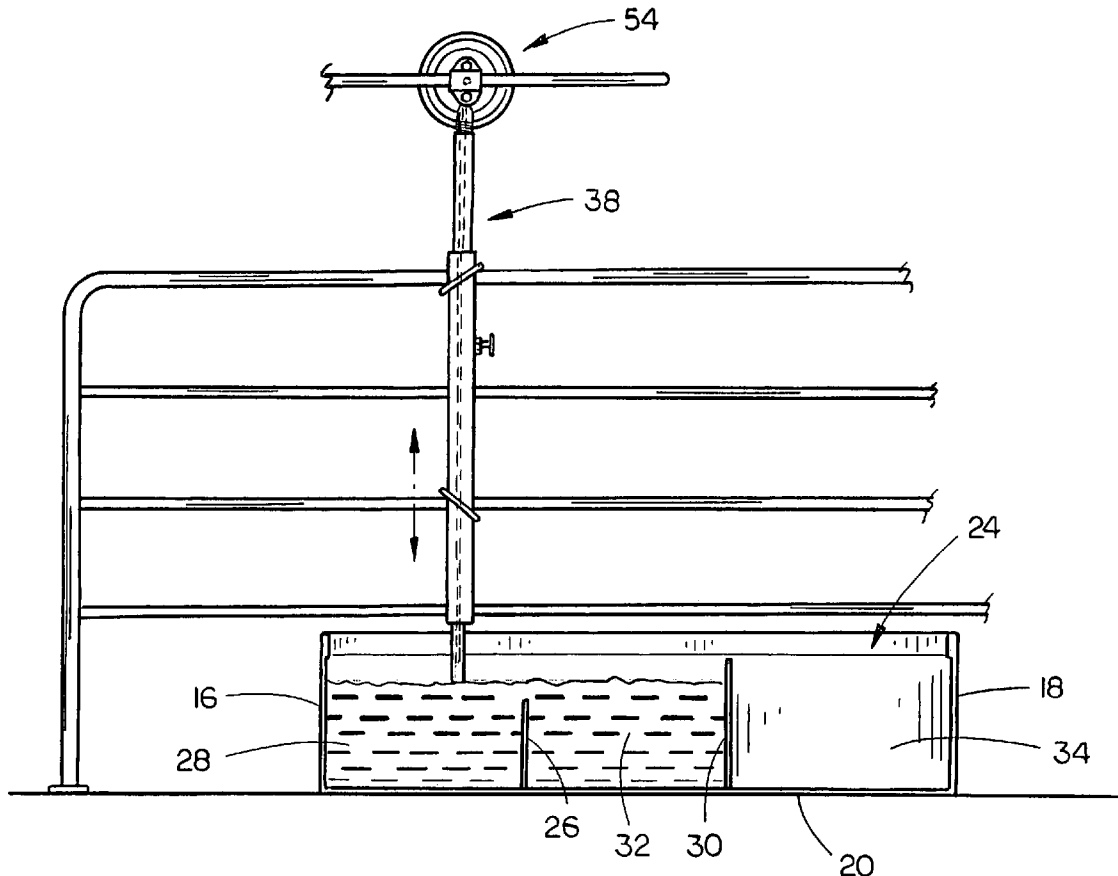

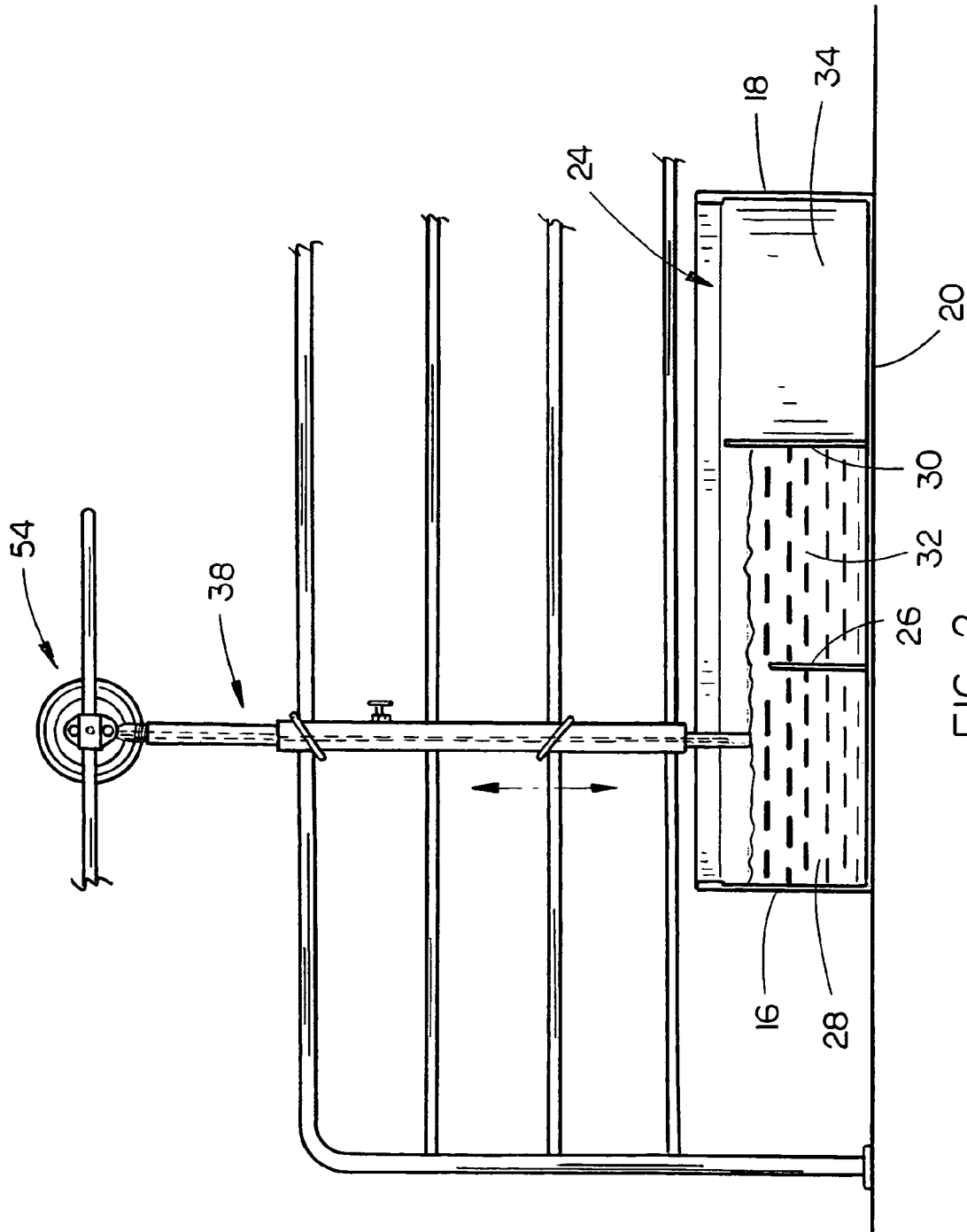

FIG. 2

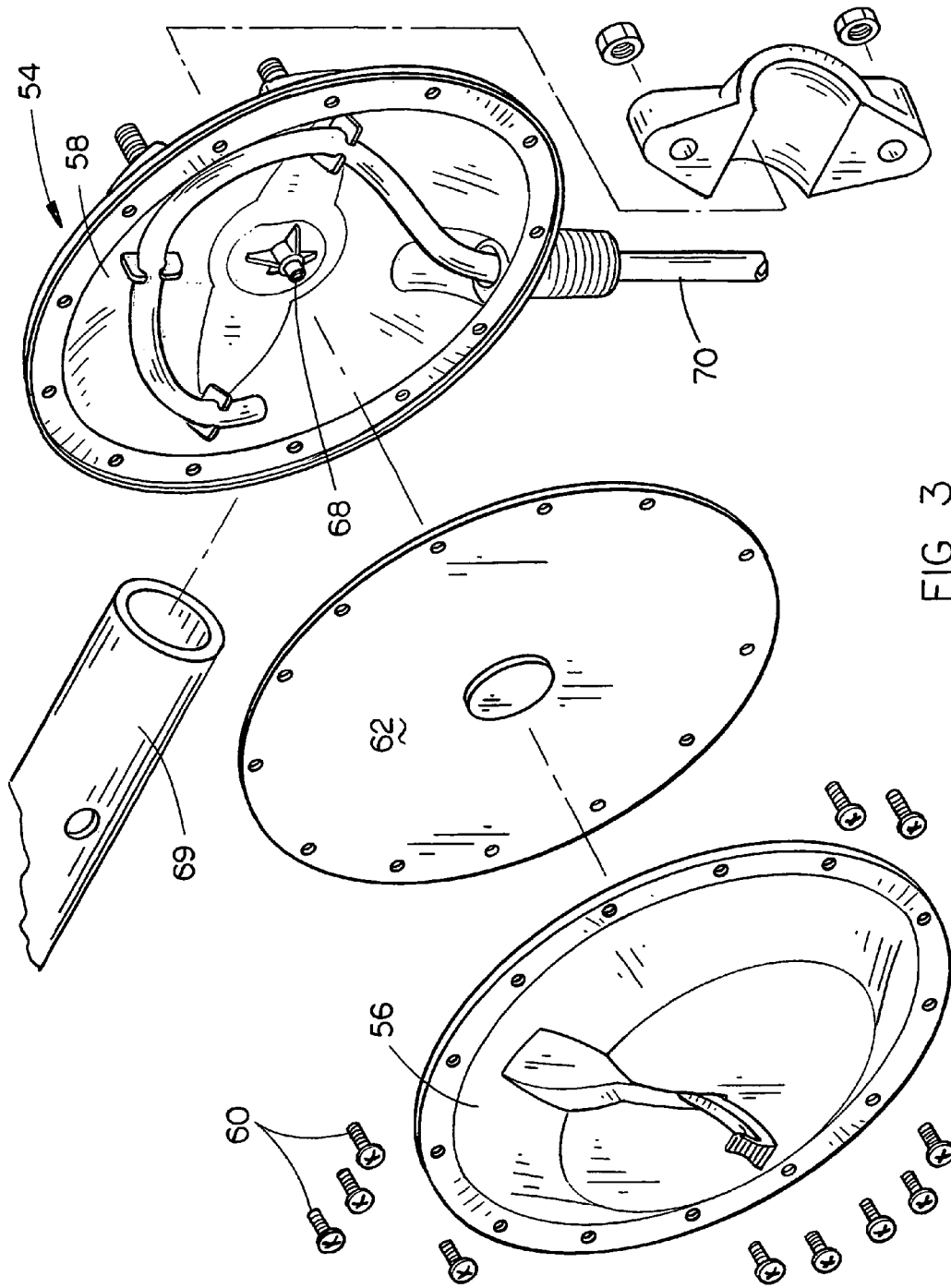

FIG. 3

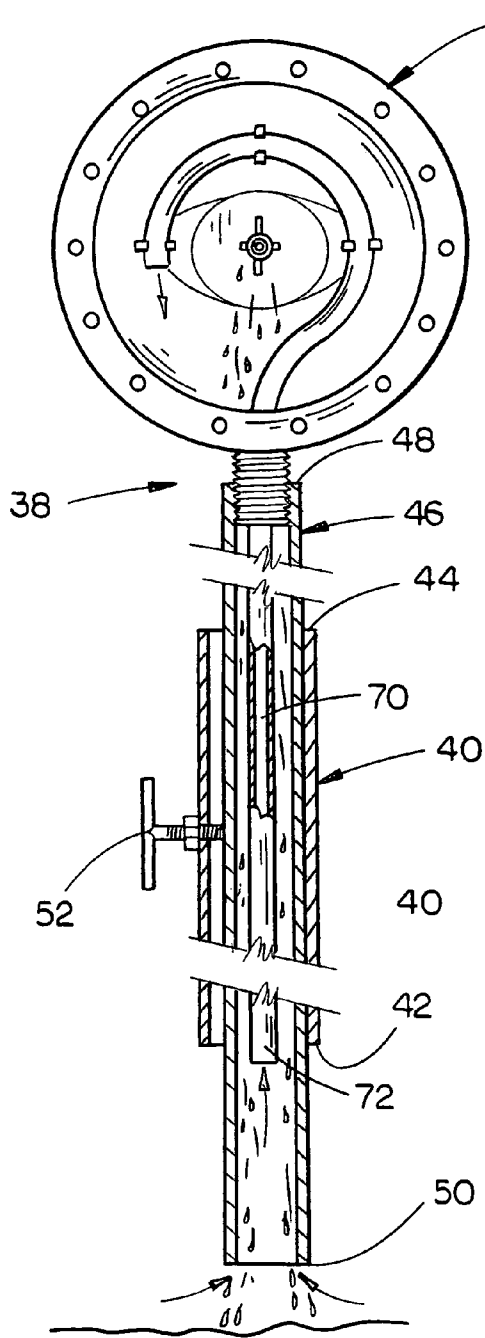

FIG. 4

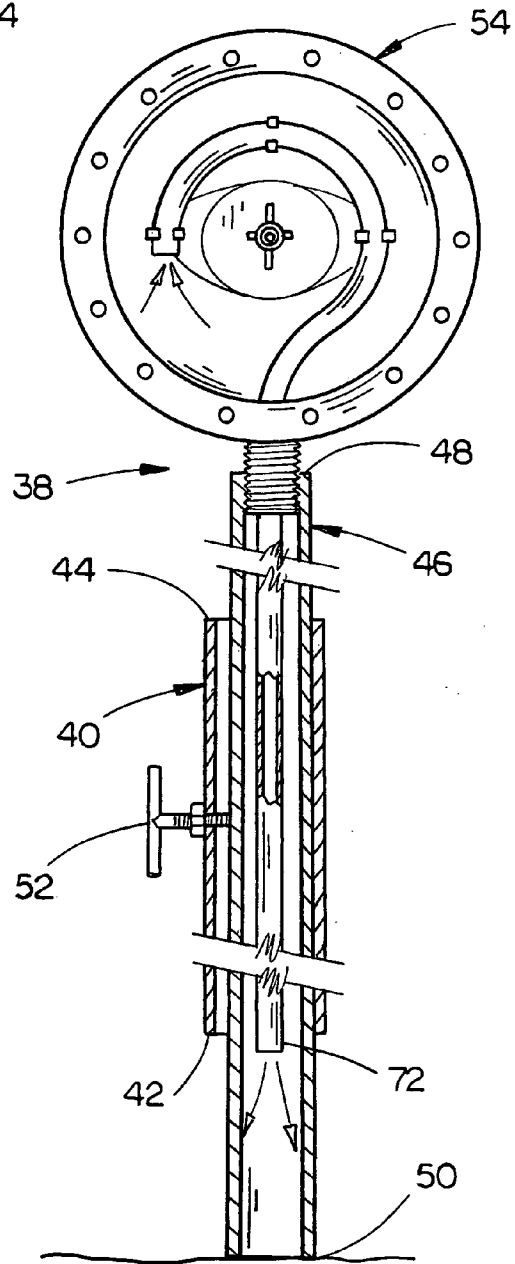

FIG. 5

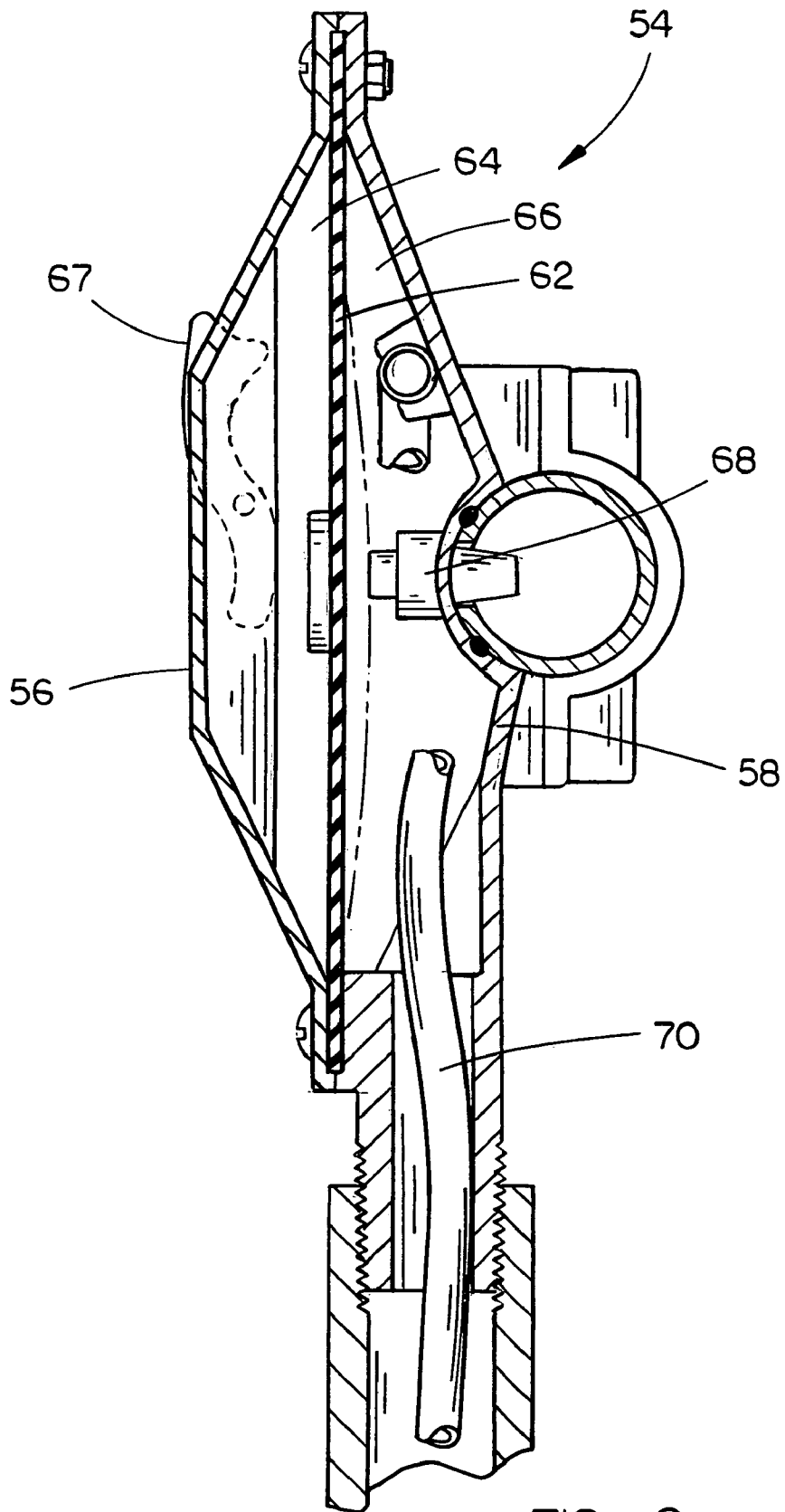

FIG. 6

WATER TRAY DRINKER FOR PIGS**CROSS-REFERENCE TO RELATED APPLICATION**

This is a divisional application of Petitioner's earlier application Ser. No. 10/649,245 filed Aug. 27, 2003, now U.S. Pat. No. 6,843,206 entitled "A WATER TRAY DRINKER FOR PIGS".

BACKGROUND OF THE INVENTION**1. Field of the Invention**

This invention relates to a watering device for animals and more particularly to a water tray drinker for pigs.

2. Description of the Related Art

The swine industry has traditionally used nipple drinkers for water presentation to the pigs within a confinement pen. The nipple drinkers have been mounted in various ways to make water available to the pigs. The primary ways are: (1) nipple drinkers mounted in the fence-line; (2) swinging nipple drinkers suspended from the ceiling in the middle of a pen; (3) nipples mounted along side tube feeders; and (4) nipples mounted in cups on the fence-line. The above-identified systems rely upon the nipple dispensing the correct water flow rate to satisfy the pigs' needs for all conditions (hot weather, over-stocking of pens and bigger pigs with increased water requirements). It is evident based upon the social and vice issues of pigs that those systems do not meet the needs of the pigs in all situations. Flow rates of nipple drinkers are highly dependent upon water pressure within the lines, orifice size of the nipples for dispensing water and the cleanliness of the screens in the nipples. If any of those elements change, the amount of water being made available to the pigs impacts social and performance of the pigs. The typical pig manager is not capable of determining flow rates at a given point in time. Those conditions can be highly variable at any point, thus creating problems with flow rates that are not discernable to the manager of the pigs.

SUMMARY OF THE INVENTION

A water tray drinker for animals such as pigs is disclosed comprising a water tray having a bottom wall, upstanding opposite first and second side walls, and upstanding opposite third and fourth side walls which define a water compartment for receiving and maintaining water therein. A plurality of horizontally spaced-apart and vertically disposed divider walls, preferably two, extend upwardly from the bottom wall and extend between the first and second side walls to separate the water compartment into a plurality of water compartment portions. If two divider walls are utilized, first, second and third water compartment portions are defined. The divider walls have progressively increasing heights from the third side wall toward the fourth side wall whereby the water compartment portions may fill progressively from the third side wall to the fourth side wall. The water compartment portion which is positioned adjacent the third side wall is in communication with a selectively adjustable valve water supply which will only fill the water compartment adjacent the third side wall unless it is adjusted upwardly to also fill the water compartment adjacent to the water compartment portion which is adjacent to the third side wall. Further upward vertical adjustment of the adjustable valve water supply will cause the water compartment portion adjacent the fourth side wall to also fill.

It is therefore a principal object of the invention to provide an improved watering tray for pigs and an associated vacuum valves system which does not rely on constant water pressure for a uniform flow rate to dispense water to pigs.

A further object of the invention is to provide a water tray for presenting water to pigs wherein the reservoir of water within the tray provides the pigs the ability to consume water quickly so that they may get in and out of a high activity area of the pen.

Still another object of the invention is to provide a water tray of the type described which reduces potential aggression and vice problems associated with inadequate water being supplied to the pigs.

Still another object of the invention is to provide an invention of the type described wherein the producer may readily observe the height of the water in the water tray to determine if the system is working correctly.

Still another object of the invention is to provide an invention of the type described above wherein water is readily available for presentation to the pigs.

Still another object of the invention is to provide watering tray of the type described which includes progressively increasing height divider walls which enables different amounts of water to be presented to the pigs.

Yet another object of the invention is to provide a water tray system of the type described above which includes a vacuum water valve which is readily adjustable.

A further object of the invention is to provide a watering tray which results in less water wastage while making a large amount of water available for individual pigs to drink.

Still another object of the invention is to provide a water tray drinker for pigs which results in fewer social, vice and aggressive behavior problems of the pigs utilizing the water tray drinker.

Yet another object of the invention is to provide a water tray drinker for pigs including a water reservoir in the tray which permits the pigs to get in and out of the water quickly, thereby minimizing the potential for aggressive and vices.

Still another object of the invention is to provide a water tray drinker for pigs of the type described which enables the producer to easily provide increased water for pig intake during peak activity periods resulting in increased feed consumption and better growth rates.

These and other objects will be apparent to those skilled in the art.

BRIEF DESCRIPTION OF THE DRAWINGS

FIG. 1 is a perspective view of the water tray drinker for pigs of this invention with the water tray being positioned between adjacent confinement pens;

FIG. 2 is a side elevational view of FIG. 1;

FIG. 3 is an exploded perspective view of the vacuum valve utilized with the invention herein;

FIG. 4 is a vertical sectional view of the adjustable valve water supply;

FIG. 5 is a view similar to FIG. 4 except that the adjustable valve water supply has discontinued the supply of water to the tray; and

FIG. 6 is a sectional view of the vacuum valve utilized in this invention.

DESCRIPTION OF THE PREFERRED EMBODIMENT

The water tray which is utilized in this invention is referred to generally by the reference numeral **10** and

includes a first side wall **12**, a second side wall **14**, a third side wall **16** and a fourth side wall **18** which extend upwardly from a bottom **20**. Preferably, the tray **10** has mounting brackets **22** extending therefrom which enable the tray to be secured to the floor of the pen by means of screws or the like extending through the brackets **22**.

The side walls **12**, **14**, **16** and **18** generally define a water compartment **24**. A first divider wall **26** extends upwardly from bottom **20** between walls **12** and **14** and it preferably has a height of 1.5 inches. As seen in the drawings, divider wall **26**, side walls **12**, **14** and **16** define a first water compartment portion **28**. A second divider wall **30** extends upwardly from bottom **20** between side walls **12** and **14** between divider wall **26** and fourth side wall **18**, as seen in the drawings, and preferably has a height of 2.0 inches. The height of walls **12**, **14**, **16** and **18** is somewhat greater than the height of divider wall **30**, as seen in FIG. 2. Divider walls **26** and **30** define a water compartment portion **32** while divider wall **30** and fourth side wall **18** define a water compartment portion **34** therebetween. Although the drawings illustrate a pair of spaced-apart divider walls, any number of divider walls could be utilized although two divider walls are preferred.

The water tray **10** is positioned on the floor of the confinement area so that it is positioned beneath the pen divider **36** with the side walls **16** and **18** and the divider walls **26** and **30** being disposed transversely to the pen divider **36**. Thus, approximately one-half of the water compartment portions **28**, **32** and **34** are accessible by the pigs on either side of the pen divider **36**.

The means for supplying water to the tray **10** is generally referred to by the reference numeral **38**. Means **38** includes a vertically disposed pipe **40** having a lower end **42** and an upper end **44**. Pipe **40** is selectively vertically adjustably secured to the pen divider wall **36** by U-clamps **45** or the like. The numeral **46** refers to a vertically disposed pipe which is selectively adjustable positioned within pipe **40** and which has an upper end **48** and a lower end **50**. The lower end **50** of pipe **46** is positioned above water compartment portion **28**, as illustrated in the drawings. The pipe **46** is selectively vertically adjustably mounted with respect to the pipe **40** by means of a set screw **52** which threadably extends through pipe **40** for engagement with the pipe **46** to maintain the pipe **46** in selective vertical positions with respect to pipe **40**.

A conventional vacuum water valve **54**, such as manufactured by Rotecna S. A., Poligono Industrial. Nave n.3, 25310 Agramunt (Lleida) Spain, is mounted to the upper end of pipe **46**, as illustrated in the drawings. Valve **54** includes casing members **56** and **58** which are secured together at their peripheries by means of bolts **60**. A diaphragm **62** is secured to the peripheries of casing members **56** and **58** to define compartment portions **64** and **66** within valve **54**. A water inlet port **68** extends inwardly through casing member **58** so that the inner end thereof is in communication with compartment portion **66** (FIG. 6). Port **68** is in fluid communication with the interior of water pipe or tube **69** which is in fluid communication with a source of water so that water is supplied to compartment portion **66**. Diaphragm **62** is adapted to seal the inner end of port **68** to prevent water from entering the interior of compartment portion **66**. Valve **54** includes a conventional water shut-off mechanism **67**.

A flexible plastic tube **70** is provided in the water vacuum valve **54**, as illustrated in FIG. 3, and has its lower end **72** positioned approximately nine inches above the lower end **50** of pipe **46**, as seen in the drawings. The lower end **50** of pipe **46** is initially positioned slightly below the upper end

of divider wall **26**. In normal operation, water is supplied to port **68** and flows downwardly between tube **70** and the interior of pipe **46** (FIG. 4) and continues to flow until water in compartment portion **28** reaches the lower end **50** of pipe **46**. When the water in water compartment portion **28** reaches the lower end **50** of pipe **46**, the vacuum within compartment **66** in the valve **54** causes the diaphragm **62** to seal upon the inner end of the inlet port **68** thereby preventing further water from flowing into compartment portion **28**. As the pigs consume water from the water compartment portion **28**, the water level in compartment portion **28** will drop below the lower end **50** of pipe **46** which will cause the diaphragm **62** to unseat from the inner end of the inlet port **68** so that additional water will be supplied to compartment portion **28** until the water level in water compartment portion **28** reaches the lower end **50** of pipe **46** which will again cause the diaphragm **62** to seal or close the inner end of water inlet port **68**.

If additional water is desired to be furnished to the pigs, the set screw **52** is loosened and the pipe **46** is raised with respect to the pipe **40** so that the lower end **50** of pipe **46** is positioned above the upper end of divider wall **26** but is positioned below the upper end of divider wall **30**. Water flowing from the lower end of pipe **46** will fill compartment portion **28** with the overflow therefrom flowing into water compartment portion **32** until the water level within the tray **10** reaches the lower end **50** of the pipe **46** which will again cause the inner end of the inlet port **68** to be sealed by the diaphragm so that additional water is not supplied to the water tray.

If even additional water is desired to be supplied to the water tray **10**, the pipe **46** is further raised with respect to pipe **40** so that the lower end **50** of pipe **46** is positioned above the upper end of divider wall **30** but is positioned below the upper end of the side walls **12**, **14**, **16** and **18** so that water compartment portion **34** will also be filled.

It can therefore be seen that the invention accomplishes at least all of its stated objectives.

I claim:

1. A watering device for animals, comprising:
 - a water tray having a bottom wall, upstanding opposite first and second side walls, and upstanding opposite third and fourth side walls which define a water compartment for receiving and maintaining water therein;
 - a plurality of horizontally spaced-apart and vertically disposed divider walls extending upwardly from said bottom wall and extending between said first and second side walls to separate said water compartment into a plurality of water compartment portions;
 - said divider walls having progressively increasing heights from said third side wall towards said fourth side wall whereby the water compartment portions may fill progressively from said third side wall to said fourth side wall;
 - said water compartment portion which is positioned adjacent said third side wall being in communication with a selectively adjustable valved water supply which will only fill said water compartment adjacent said third side wall unless it is adjusted to also fill the water compartment portion adjacent to said water compartment portion which is adjacent to said third side wall.
2. A water device for animals, comprising:
 - a water tray having a bottom wall, and upstanding opposite first and second side walls, and upstanding opposite third and fourth side walls which define a water compartment for receiving and maintaining water therein;

5

a first divider wall extending upwardly from said bottom wall and extending between said first and second side walls to define a first water compartment portion between said third side wall and said first divider wall; a second divider wall extending upwardly from said bottom wall and extending between said first and second side walls to define a second water compartment between said first and second divider walls; said second divider wall and said fourth side wall defining a third water compartment portion therebetween; said first divider wall having a height less than the height of said second divider wall;

6

said second divider wall having a height less than the height of said side walls; said first water compartment portion being in communication with a selectively adjustable valved water supply which will only fill said first water compartment portion unless it is adjusted to also fill said second water compartment portion and which will only fill said first and second water compartment portions unless it is adjusted to also fill said third water compartment portion.

* * * * *