

Nov. 18, 1924.

1,515,705

F. SHORT

BOMB

Filed May 4, 1923

2 Sheets-Sheet 1

Fig. 1

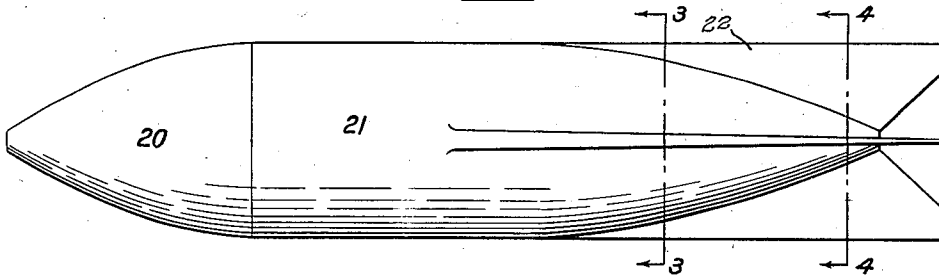

Fig. 2.

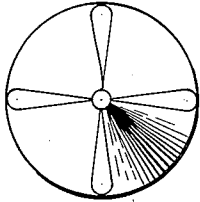

Fig. 3.

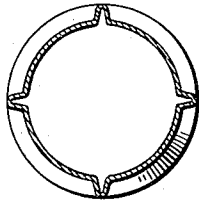

Fig. 4.

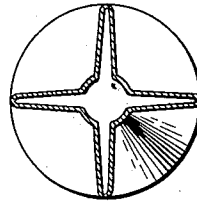

Fig. 5.

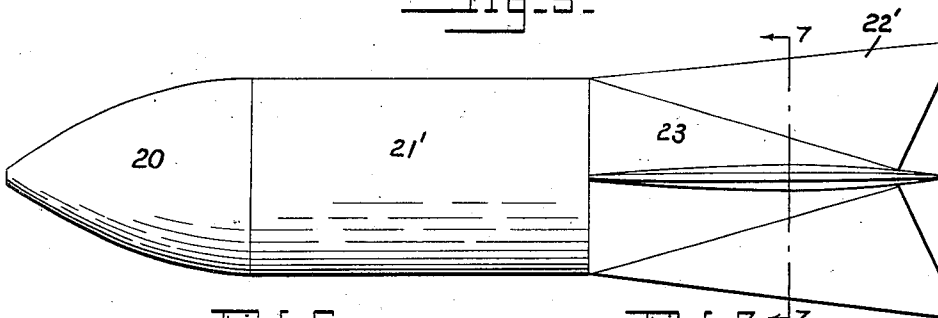

Fig. 6.

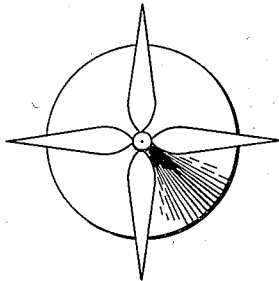
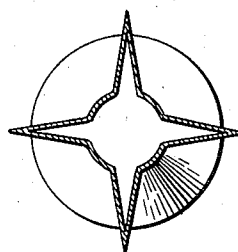

Fig. 7.



INVENTOR  
*Frank Short*  
BY *W. M. Roach*  
ATTORNEY

Nov. 18, 1924.

1,515,705

F. SHORT

BOMB

Filed May 4, 1923

2 Sheets—Sheet 2

Fig. 8.

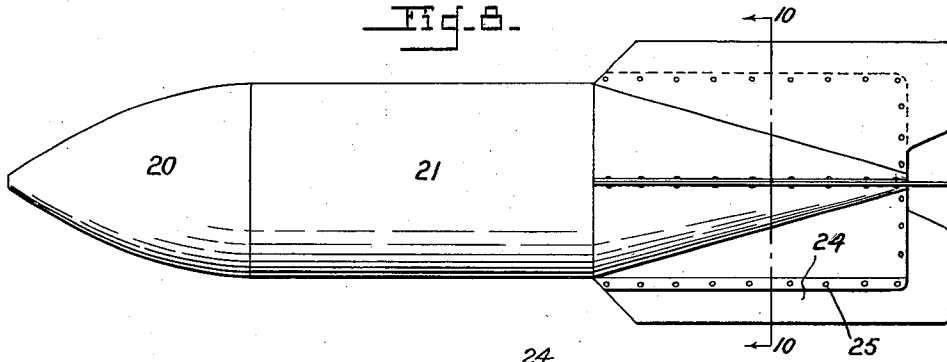

Fig. 9.

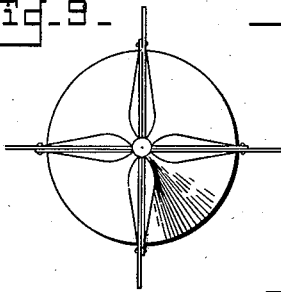

Fig. 10.

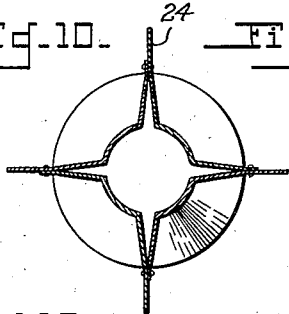

Fig. 11.

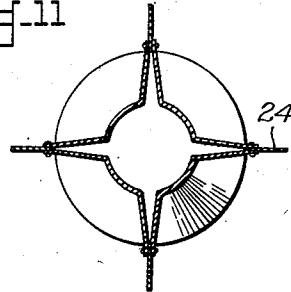

Fig. 12.

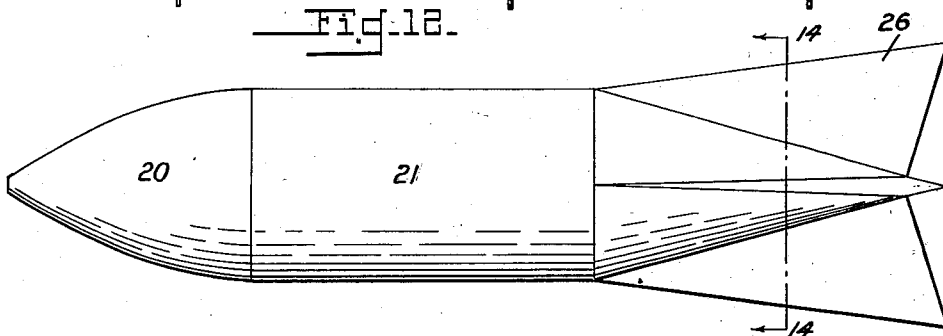

Fig. 13.

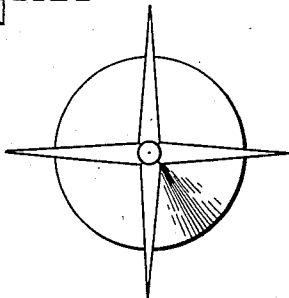

Fig. 14.

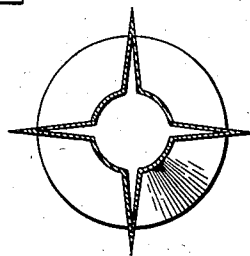
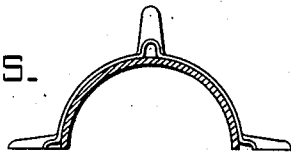

Fig. 15.



INVENTOR  
*Frank Short*  
BY *W. M. Roach.*  
ATTORNEY

## UNITED STATES PATENT OFFICE.

FRANK SHORT, OF PENN YAN, NEW YORK.

BOMB.

Application filed May 4, 1923. Serial No. 636,743.

(FILED UNDER THE ACT OF MARCH 3, 1893, 22 STAT. L., 625.)

*To all whom it may concern:*

Be it known that I, FRANK SHORT, a citizen of the United States, and a resident of Penn Yan, county of Yates, and State of New York, have invented an Improvement in Bombs, of which the following is a specification.

The invention described herein may be used by the Government, or any of its officers or employees in prosecution of work for the Government, or by any other person in the United States, without payment to me of any royalty thereon, in accordance with the act of March 3, 1883.

The subject of this invention is a bomb, the invention relates more specifically to the stabilizing fins of a bomb.

In the construction of bombs it is necessary that the tail fins be properly braced in order that they may withstand the pressure placed upon them during flight as well as to avoid distortion of the fins during handling and shipment.

The present invention provides a fin structure which gives a self braced fin thereby avoiding the necessity for stays or braces between the fins.

It is also an object of the invention to provide a fin or fins between which a confined air space is provided so as to stabilize the bomb.

With the foregoing and other objects in view, the invention resides in the novel arrangement and combination of parts and in the details of construction hereinafter described and claimed, it being understood that changes in the precise embodiment of the invention herein disclosed may be made within the scope of what is claimed without departing from the spirit of the invention.

A practical embodiment of the invention is illustrated in the accompanying drawing, wherein:

Fig. 1 is a view in elevation of a bomb constructed in accordance with my invention;

Fig. 2 is a rear end elevation of the same;

Fig. 3 is a section on the line 3—3 of

Fig. 1;

Fig. 4 is a section on the line 4—4 of

Fig. 1;

Fig. 5 is a view in elevation of a bomb showing a further modification of the fins;

Fig. 6 is a rear end elevation;

Fig. 7 is a section on the line 7—7 of 55  
Fig. 5;

Fig. 8 is an elevation of the bomb showing a still further modification of the fins;

Fig. 9 is a rear end elevation of the same;

Fig. 10 is a section on the line 10—10 of 60  
Fig. 8;

Fig. 11 is a sectional view showing a still further modification of the fin shown in Fig. 8;

Fig. 12 is an elevation of a bomb showing 65  
a still further modification of the fin;

Fig. 13 is a rear end elevation of the same;

Fig. 14 is a section taken on the line 14—14  
of Fig. 12; and

Fig. 15 is a detail sectional view of fins 70  
formed to provide air passages therethrough.

Referring to the drawings by numerals of reference:

The usual bomb nose is shown at 20 to which is attached in any suitable manner 75  
the bomb body 21 which is formed from tubular material swaged on a suitable mandril to draw the rear end of the tube to proper stream line as shown and at the same time fold spaced apart portions 80  
of the tube outwardly to form fins 22 substantially of V-shape in cross section, the fins in this instance being preferably stream lined or tapered toward their rear end.

In Fig. 5 is shown a tubular body 21' 85  
connected to the bomb nose and to the rear end of the body is connected a tail piece 23 which is formed preferably of tubular material placed upon a suitable mandril and swaged to draw the tube to a cone and to 90  
fold spaced apart portions of the tube outwardly to form the fins 22' which are substantially of V shape in cross section and which at the point of joining with the cone gradually taper toward the front and rear 95  
ends thus giving a stream line effect with a strong bracing for each fin.

In Fig. 8 I have shown a tail piece and fin made of separate sections which are swaged or stamped to form a quadrant of a 100  
tail cone with half of two fin members integral with the longitudinal edges of the cone member. One member of each fin member has an extended portion 24 which forms a vane for stabilizing the bomb. The members 105  
may be conveniently joined together by rivets 25 or in any other suitable manner.

In Fig. 11 the same form of tail piece and fin is shown with the exception that the vane 24' is made of a separate piece clamped between the fin members to which it is riveted or otherwise joined. While the vane as herein shown is a separate piece of sheet metal it is to be understood that the same may be integral with the fin proper, in which instance the vane would be divided along its inner edge to form the fin, or it may be of sheet metal folded upon itself to form a fin of V or Y shape in cross section, and secured to the tail piece or bomb body along its two edges.

The modified tail piece and fin shown in Fig. 12 is constructed in the same manner as the fins heretofore described, the difference being that the fins 26 are wider at the rear end than at the forward end thus producing a certain amount of vacuum at the rear end of each fin and so controlling to some extent the flight of the bomb.

In Fig. 15 a fin similar to that shown in Fig. 1 is illustrated the fin being open at the forward end so as to provide an air

passage therethrough thus aiding in stabilizing the bomb during flight.

While I have illustrated and described herein fins made integral with the tail piece, it is to be understood that the fins may be formed separately and attached by riveting or welding to the tail piece or bomb body.

I claim:

1. A bomb, embodying a tail piece, fins integral with the tail piece of substantial V-shape in cross section, each fin open to provide an air passage therethrough.

2. A method of forming self braced bomb fins, consisting of drawing a tube into a cone and at the same time folding portions of the tube at spaced apart intervals thereabout outwardly.

3. A bomb, embodying a tail piece, fins carried by the tail piece of substantially V-shape in cross section, the walls of the fins spaced farther apart at points in advance of the trailing edges.

FRANK SHORT.