

19



Europäisches Patentamt  
European Patent Office  
Office européen des brevets



11 Publication number:

**0 609 650 A1**

12

**EUROPEAN PATENT APPLICATION**

21 Application number: **94100055.6**

51 Int. Cl.<sup>5</sup>: **B65D 43/16, B65D 51/28**

22 Date of filing: **04.01.94**

30 Priority: **05.02.93 IT GE930003 U**

43 Date of publication of application:  
**10.08.94 Bulletin 94/32**

84 Designated Contracting States:  
**AT BE CH DE DK ES FR GB GR IE LI LU MC  
NL PT SE**

71 Applicant: **MIRA LANZA S.P.A.**  
**Via Lampedusa 11/A**  
**I-20141 Milano(IT)**

72 Inventor: **Berveglieri, Fabrizio**  
**17, Viale B. Brea**  
**I-16131 Genova(IT)**

74 Representative: **Porsia, Attilio, Dr. et al**  
**c/o Succ. Ing. Fischetti & Weber**  
**Via Caffaro 3/2**  
**I-16124 Genova (IT)**

54 **Box, particularly for washing powders, with cardboard cut-out container and plastic closure piece.**

57 Box for detergent in powder or flake form comprising a cardboard cut-out container body (2) and a plastic closure piece (3) consisting of a frame (31) and a lid (32) hinged to said frame. The peripheral dimensions of this frame are approximately equal to those of said container body, and the frame is attached to the container body (2) by a lower portion (310), the perimeter of which is smaller, this portion (310) being inserted inside the container body. The lid (32) also has a cavity (33) in which devices (4) for measuring out and/or dispensing the detergent in powder or flake form may be housed.

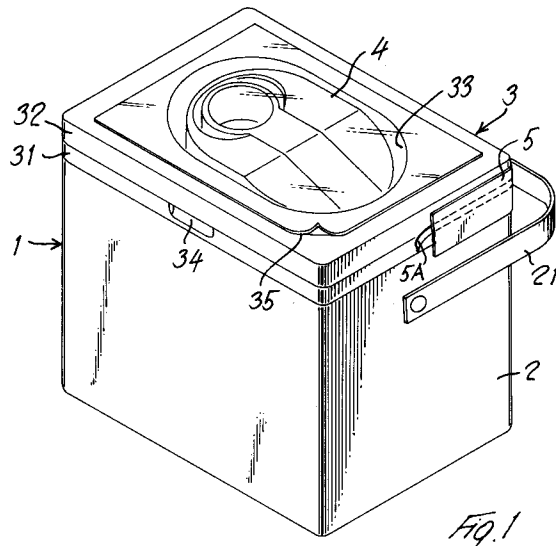

**EP 0 609 650 A1**

The invention relates to boxes for holding powdered products, and especially to boxes for holding detergents in powder or flake form.

Said boxes often take the form of a container body whose shape may be cylindrical or parallelepipedal and which is open at one end, this end being closed by means of a lid attached in a variety of ways to the container body.

The object of the invention is to provide a box having a closure piece fixed firmly and securely to the container body and which together can house devices for measuring out and/or dispensing the detergent in powder or flake form.

This object is achieved by means of a box for detergent in powder or flake form according to the present model comprising a cardboard cut-out container body with a damp-proof barrier and a plastic closure piece consisting of a frame and of a lid hinged to said frame, in which the external peripheral dimensions of the frame of said closure piece are equal to those of the container body and the frame is attached to it by means of a lower portion, the perimeter of which is smaller, this portion being inserted inside the box, and in which said lid has a cavity suitably shaped by an injection process, as is the whole lid, in which devices for measuring out and/or dispensing the detergent in powder or flake form are housed.

Advantageously said frame is fixed to the container body by means of adhesive tape wound one or more times around the container so that it adheres both to the rim of said container and to the frame. Said sealing tape is advantageously provided with a plastic strip so that it can be torn open in the most suitable place.

The lid may also be covered, for sales purposes, with a thin transparent plastic sheet which will hold the measuring and/or dispensing devices in place.

Additional advantages and further characteristics will become clearer in the course of the following detailed description of one box of the invention. This description, which does not imply any restriction, refers to the accompanying drawings in which:

Figure 1 is a perspective view of a box according to the invention in a closed position;

Figure 2 is a view, similar to Fig. 1, of the box in the open position; and

Figure 3 is a view of a longitudinal section of the box shown in the previous figures.

In Figure 1, the box according to the invention is indicated by 1. This box is made up of a cut-out container body 2 of cardboard or some similar material, having a damp-proof barrier; a plastic closure piece 3 consisting of a frame 31 inserted into and joined to the container body 1; and a lid 32 attached firmly to said frame 31 on one side, by

means of the hinges 36 (Fig. 3), and on the other side by means of the openable catch 34 which can be released by pressure (Figs 1 and 2). The frame 31 is fixed to the container body 2 by the adhesive tape 5 wound once around them as illustrated. The sealing tape in turn is provided with a plastic strip 5A for tearing open the adhesive tape: this strip is positioned in the best place for easy opening of the lid 32.

The lid 32 has a cavity 33 which is open on its upper face and which can contain a measuring/dispensing device 4; this cavity is covered in some suitable way by a transparent plastic sheet 35.

The frame 31 is inserted into the container body 2 by its lower portion 310 whose perimeter is smaller than that of the container body 2; meanwhile the upper part of the frame 31 rests on the rim of said container 2 and has the same peripheral dimensions as it. This enables said frame 31 to be fixed to the container body 2 by means of the adhesive tape 5 with its strip 5A used to open it; moreover, given that the frame and the container have the same peripheral dimensions, as has been pointed out, the absence of projections prevents any contact and/or knocks between boxes while in storage and/or while being transported, which would otherwise impair the usefulness of the packaging.

The absence of projections also means that the contents can be sealed against damp and at the same time keeps in the scent.

The box also has a plastic handle 21 for easy carrying.

## Claims

1. Box for detergent in powder or flake form comprising a cardboard cut-out container body (2) fitted with a plastic handle (21) and a plastic closure piece (3) consisting of a frame (31) and of a lid (32) hinged to said frame, in which the external peripheral dimensions of the frame (31) of said closure piece (3) are approximately equal to those of the container body (2) and the frame is attached to it by means of a lower portion (310), the perimeter of which is smaller, this portion being inserted inside the container body (2), and the frame (31) being fixed to said container body (2) by fixing means (5); and in which said lid (32) has a cavity (33) suitably shaped by an injection process, as is the whole lid, in which devices (4) for measuring out and/or dispensing the detergent in powder or flake form are housed.
2. Box according to Claim 1, in which said cavity (33) is covered with a thin transparent plastic

sheet (35).

3. Box according to Claim 1 or 2, in which said fixing means (5) and (5A) are an adhesive tape and a tearing strip.

5

10

15

20

25

30

35

40

45

50

55

3

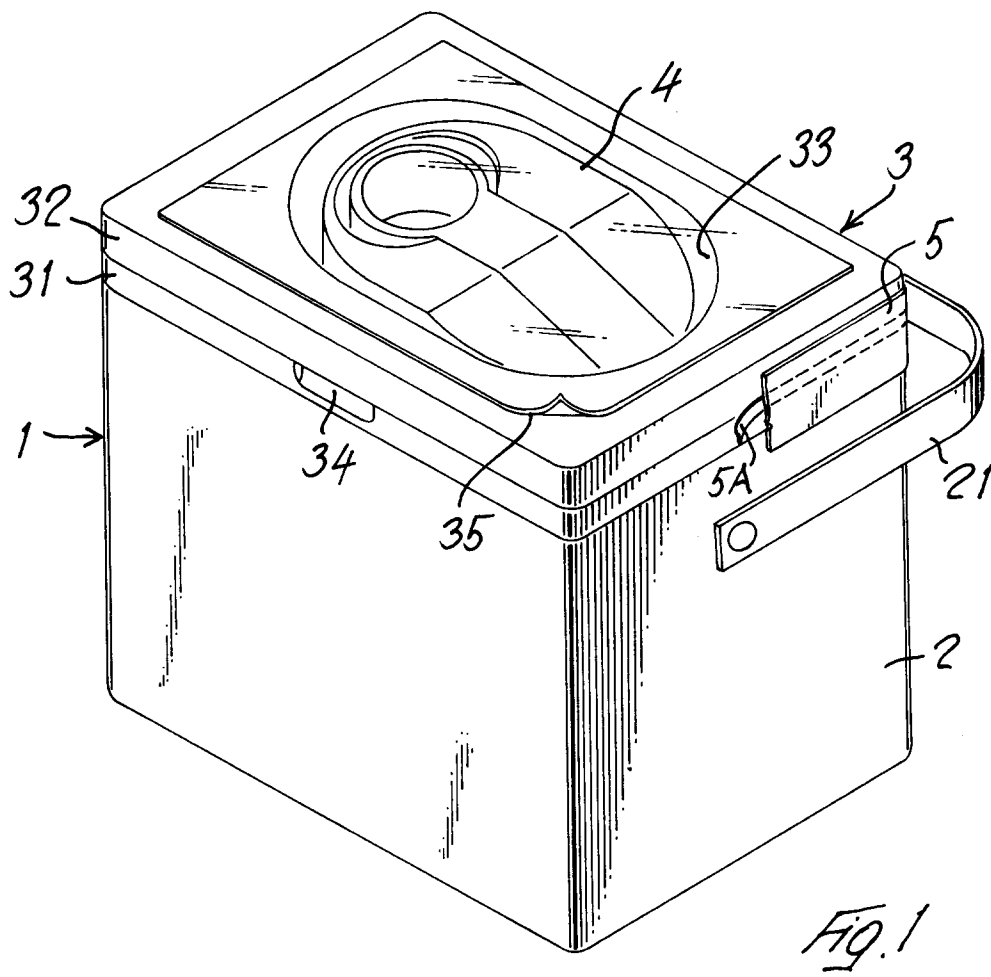

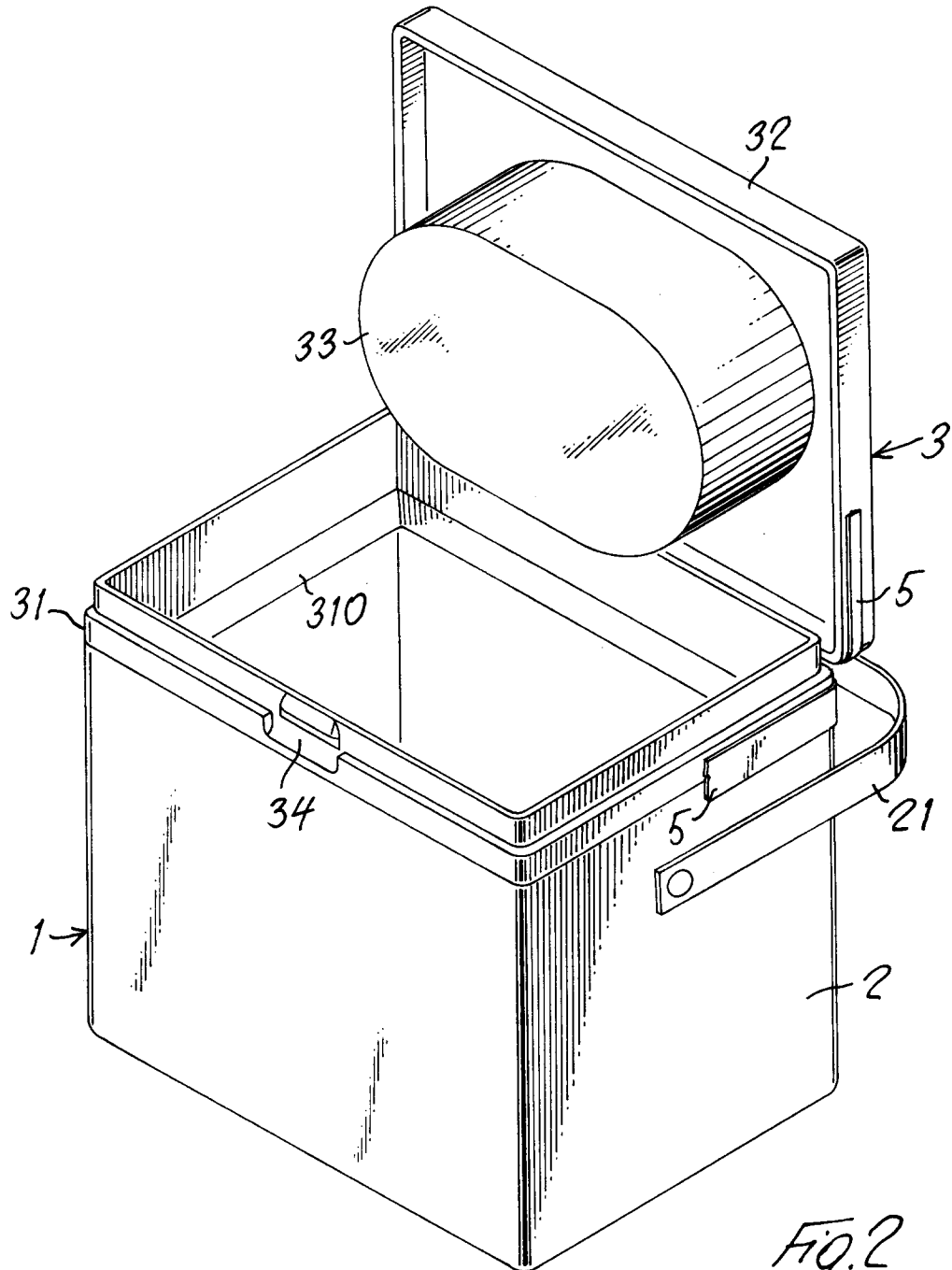

Fig. 2

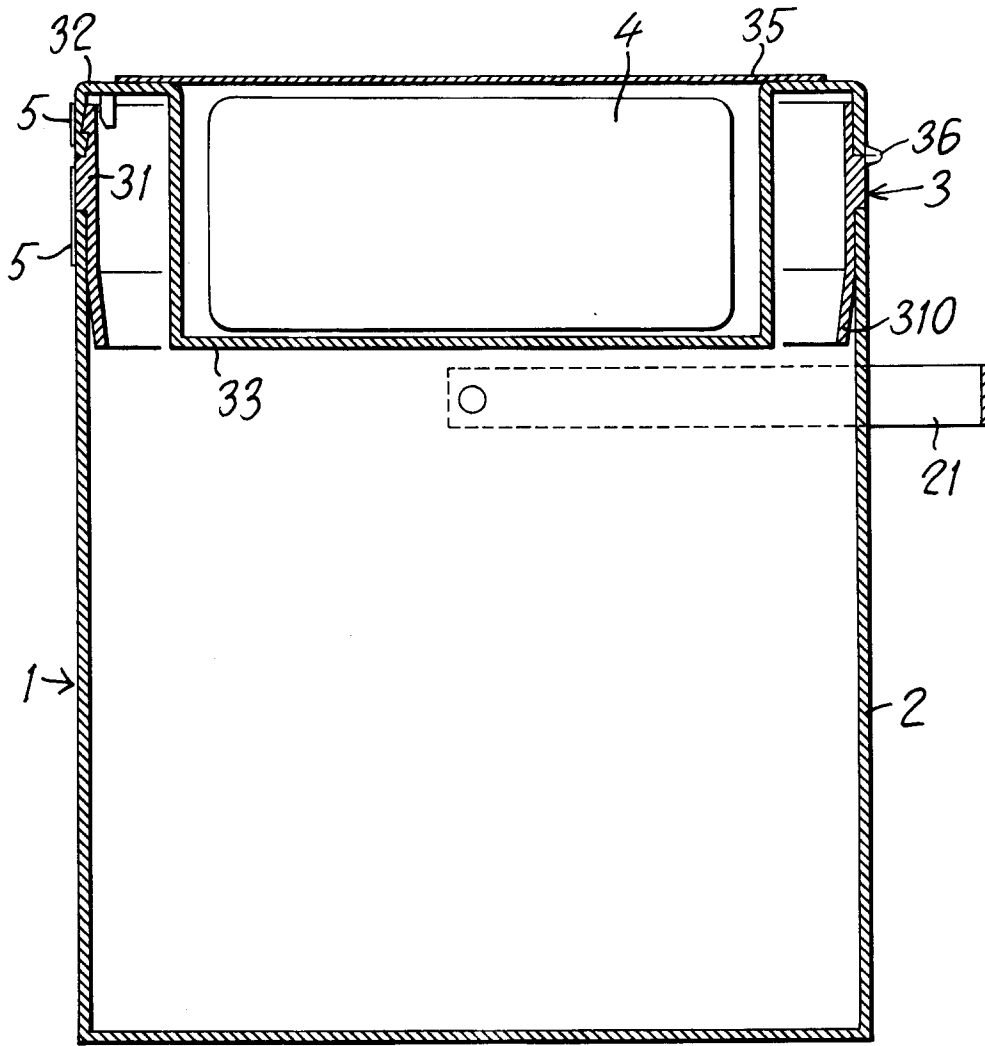

Fig. 3



European Patent  
Office

EUROPEAN SEARCH REPORT

Application Number  
EP 94 10 0055

DOCUMENTS CONSIDERED TO BE RELEVANT			
Category	Citation of document with indication, where appropriate, of relevant passages	Relevant to claim	CLASSIFICATION OF THE APPLICATION (Int.Cl.5)
Y	US-A-4 293 079 (LYTLE) * column 2, line 49 - column 4, line 39; figures 1,2,6 *	1	B65D43/16 B65D51/28
Y	---		
A	GB-A-1 327 355 (FIRST DYNAMICS) * page 2, line 19 - line 49; figures 1,2,6 *	1 2	
A	---		
A	FR-A-2 538 784 (MONOPLAST) * claims 1,2; figure 1 *	1	
A	---		
A	FR-A-1 465 848 (HENKEL) * page 1; figures 1,2 *	1,3	
A	---		
A	DE-U-87 16 585 (ESKO KASEWERK) * claims 1,5; figures 1-3 *	1,2	
A	---		
A	EP-A-0 087 088 (THOMIN) -----		
The present search report has been drawn up for all claims			
Place of search		Date of completion of the search	Examiner
THE HAGUE		3 May 1994	Bessy, M
CATEGORY OF CITED DOCUMENTS		T : theory or principle underlying the invention E : earlier patent document, but published on, or after the filing date D : document cited in the application L : document cited for other reasons ----- & : member of the same patent family, corresponding document	
X : particularly relevant if taken alone Y : particularly relevant if combined with another document of the same category A : technological background O : non-written disclosure P : intermediate document			

EPO FORM 1503 03.82 (P04C01)