

609107

APPLICATION FOR A STANDARD PATENT
OR A STANDARD PATENT OF ADDITION

Insert full name(s) of applicant(s)
(71) I/We ARTHUR GEORGE YARRINGTON
of MS 1073 CROW'S NEST 4355, QUEENSLAND AUST.

Insert title of invention
(54) hereby apply for the grant of a standard patent patent of addition for an invention entitled
"SOLAR OPTIC LAMP"
(tick appropriate box)
which is described in the accompanying provisional complete specification.

Insert name of actual inventor
(72) The actual inventor(s) of the said invention is/are A. G. YARRINGTON

Insert address for service of notices in Australia
(74) My/our address for service is MS 1073 Crow's Nest, 4355, Q. Aust.
Attorney Code.....

*THESE SECTIONS ARE ONLY TO BE COMPLETED WHERE APPLICABLE:

(ONLY TO BE USED IN THE CASE OF A CONVENTION APPLICATION)

Details of basic application (s) -

(31) Number of basic application

(33) Name of Convention country in which basic application was filed ISO Code

(32) Date of basic application

(ONLY TO BE USED IN THE CASE OF A FURTHER APPLICATION MADE BY VIRTUE OF SECTION 51)

(62) Number of original application APPLICATION ACCEPTED AND AMENDMENTS

Person by whom made ALLOWED 30.1.91

(ONLY TO BE USED IN THE CASE OF AN APPLICATION FOR A PATENT OF ADDITION)

I request that the patent may be granted as a patent of addition to the patent applied for on

(61) Application No. Patent No.

in the name of

I request that the term of the patent of addition be the same as that for the main invention or so much of the term of the patent for the main invention as is unexpired.

LODGED AT SUB-OFFICE
29 MAR 1988
Brisbane

Insert day, month and year form signed
Dated this 21st day of March 1988

Signature of applicant or Australian attorney
TO Arthur George Yarrington
(Signature)

THE COMMISSIONER OF PATENTS

This form must be accompanied by either a provisional specification (Form 9 and true copy) or by a complete specification (Form 10 and true copy).

Patents Act 1952

DECLARATION IN SUPPORT OF AN APPLICATION FOR A PATENT

In support of the Application made by A.G. YARRINGTON.

for a patent for an invention entitled "SOLAR OPTIC LAMP"

I, ARTHUR GEORGE YARRINGTON
of MS 1073 CROW'S NEST 4355 QUEENSLAND AUST

do solemnly and sincerely declare as follows:-

1. I am the applicant for the patent. Yes.
(or, in the case of an application by a body corporate)

1. I am authorized by ~~.....~~
the applicant for the patent to make this declaration on its behalf.

2. I am the actual inventor of the invention. Yes.
(or, where a person other than the inventor is the applicant)

2. ~~.....~~
of ~~.....~~ is the actual inventor of the invention and the

Key

facts upon which I am the ~~.....~~ is entitled to make the application are as follows:-

Declared at CROW'S NEST this 21st day of March 1988.

A.G. Yarrington
(Signature of Declarant)

TO :

THE COMMISSIONER OF PATENTS.

This document contains the amendments made under Section 49 and is correct for printing.



PATENTS ACT 1959

609107

P/00/011
Form 10

COMPLETE SPECIFICATION

(ORIGINAL)

FOR OFFICE USE

Short Title:

Int. Cl.:

Application Number:
Lodged:

Complete Specification—Lodged:
Accepted:
Lapsed:
Published:

Priority: *AU/PI1154-31-03-87*

Related Art: *2491* SUB-OFFICE
2 MAR 1988
Brisbane

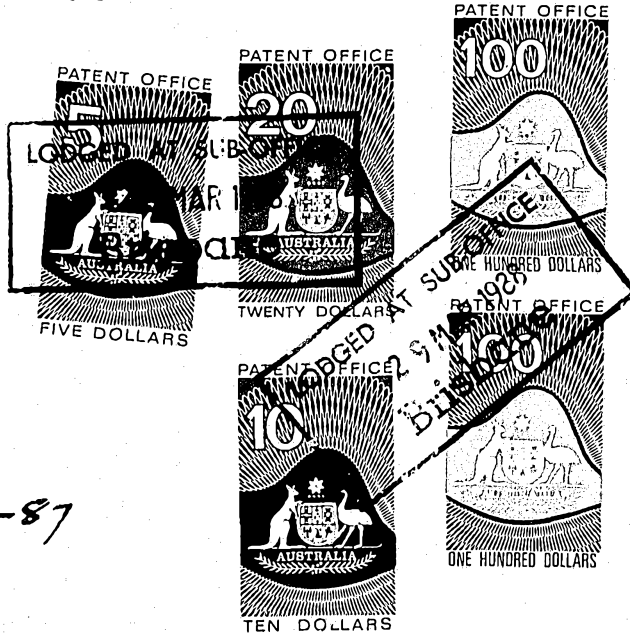

TO BE COMPLETED BY APPLICANT
Name of Applicant: *ARTHUR GEORGE YARRINGTON*

Address of Applicant: *MS. 1073 CROW'S NEST 4355, QUEENSLAND, AUST.*

Actual Inventor: *A. G. YARRINGTON*

Address for Service: *MS. 1073 CROW'S NEST, 4355, QUEENSLAND, AUST.*

Complete Specification for the invention entitled: *"SOLAR OPTIC LAMP"*

The following statement is a full description of this invention, including the best method of performing it known to me:—

* Note: The description is to be typed in double spacing, pica type face, in an area not exceeding 250 mm in depth and 160 mm in width, on tough white paper of good quality and it is to be inserted inside this form.

TITLE : " SOLAR OPTIC LAMP:

The invention is concerned with a device to collect and concentrate solar radiation energy by optical means.

Light radiation energy is conveyed by a series of optical fibre light guide means as the transport means to light radiation emitting fixtures and processes. Cold light radiation when applied to recipient devices such as luminaires as solar lamps would provide a worthwhile illumination device.

The device of the invention provides a novel form of optical concentrator/collector means to be placed in an open area to capture the
10. suns solar energy. A series of optical fibre light guides attach to the Sun Tracking Module to form the radiation transporting means to convey the energy to a solar optic lamp or other radiation dependent equipment relating to a great many applications and uses. The use of an effective radiation concentrator/collector means married to an efficient light-guide transport means allows the energy to be piped to remote areas to furnish illumination and heating energy.

Natural passive lighting systems used in large buildings require valuable space to be taken up by light wells to allow light to get down to confined areas of the building for illumination purposes within the
20. building. This arrangement is costly and often difficult to incorporate into the building design space available.

Whereas with the optical fibre light guide system provided by the present invention , natural light rays may be effectively channelled to any remote or desired area of a building at virtually no operational cost by the use of the naturally provided solar energy.

Advantages to be gained are cheap abundant energy for effective illumination and sterilization of confined areas away from normal natural lighting conditions.

A bonus factor is the heat reclamation to be won from heat exchangers
30. in the liquid circuit utilizing the non-visible radiation energy collected.

The invention has wide application to underground mining, tunnelling, and explosive situations and underground shelters.

The device may be produced in an economical manner and readily put into service , other advantages will be apparent from the following description.



2.

The invention has been devised to provide an efficient suntracking radiation concentrator/collector means coupled to a multi-core optical fibre light guide cable comprised as the light radiation transport means.

The solar radiation concentrator/collector means of the apparatus provides by the array of focusing lenses a means to divide an area of incident solar radiation into a series of concentrated focused small diameter light beams which pass into the optical receptor terminals to enter the proximal ends of the optical fibre light guides to be channelled to remote emission points for illumination purposes and processes.

10. Such recipient devices are solar lamps and radiators.

Previous known apparatus required the solar radiation spectrum to be divisionally classified by a fresnel lens focusing means into various wave bands so that only the radiation visible light component entered the optical fibre light guide transporting means. A large percentage of the energy being lost as reflected and dissipated heat.

Whereas the present invention provides for greater efficiencies with the capturing of most of the solar radiation energy falling on the collector.

20. The process of focusing the solar radiant energy through a transparent refractive liquid such as water allows for a greater amount of the visible light radiation to be focused into the optical fibre light guide means. This process occurs due to the known refractive qualities of water to provide total reflectivity within the liquid.

In the present process non-visible rays such as ultra-violet and infra-red are absorbed by the refractive liquid acting as an optical frequency converter to filter this energy out of the solar radiation spectrum for reclamation as a usable source of heat energy.

30. As another important function, the circulating liquid maintains the optical fibre terminals within suitable temperature parameters. Cooling may also be provided by a circulating liquid line being co-axially included in the cable in conjunction with the optical fibre light guides connecting between the solar tracking module and the radiation recipient devices.

2.



BROAD DESCRIPTION OF THE INVENTION

According to the invention the apparatus may consist of an array of optical focusing lenses arranged as a concentrator/collector means to concentrate and collect solar incident radiation by an optical focusing means arranged as a sun tracking module.

Array of optical focusing lens means may be formed as a watertight sealed window located as the upper wall of the liquid filled compartment, house^d as a component of the sun tracking module.

A series of small diameter flexible optical fibre light guides independently attach by a connectable means to a series of optical recep-
10. -tor terminals located within the confines of the base side of the liquid filled compartment . Said optical receptor terminals align with the focus path of the concentrator lens means so that the window of the optical receptor terminal is located at the optical concentrators focal point. Aligned optically with the light beam optical receptor terminals window are the optical fibre light guide means whereby attachment is made to said optical receptor terminals by connectable means.

Accepted light radiation energy would be conveyed by the array of connectable optical light guides as a bunched cable to remote light radiat-
-ion recipient devices such as luminaires for illumination applications .

20. An important characteristic feature of the invention relates to the use of a liquid filled compartment in the solar radiation concentrator/collector means of the sun tracking module. A large percentage of the non-visible solar radiation would be removed during focusing through the transparent liquid such as water . Reclaimed energy in the form of heat may be applied to adjacent heat reliant devices and processes.

BRIEF DESCRIPTION OF THE DRAWINGS:

Figure 1 shows a general schematic view of one preferred form of the invention , illustrated as the Solar Tracking Module.

Figures 2,3,4 ,5 and 6 show various arrangements of the solar optic lamps
30. attached to the emission end of the light radiation transport means.

Figure 7 shows a schematic arrangement of the components embodied in a broad concept of the invention.

Figure 8 shows a single peice lens molding formed as an array of focusing lenses , said array of focusing lenses form the upper sealed window wall of the liquid filled compartment.



4.

Figure 9 shows a view in cross-section of a single molded lens panel formed in glass or plastic material.

Figure 10 shows an assembled array of separately formed focusing lenses.

Figure 11 shows a sectional view in cross-section of the assembled lenses.

Figure 12 shows a view in cross-section as part of a frustro-conical concentrator/collector component of a sun tracking module.

DETAILED DESCRIPTION OF THE INVENTION.

Figure 1 shows a typical embodiment of the device of the invention as a sun tracking module comprising an optical concentrator/collector 10. means combined with a light radiation transport means .

Sun tracking module 1 houses a liquid filled compartment 15 wherein the upper wall of said liquid filled compartment 15 formed as a window, houses the light radiation optical concentrator/collector means comprised as an array of optical focusing lens means 2.

Liquid filled compartment 15 requires the use of a liquid such as water as the light refractive liquid.

Liquid filled compartment 15 has inlet 19 and outlet 20 adaptors to which liquid conveying lines 13 attach to join an adjacent circulator/heat exchanger means, placed as a separate component to the sun tracking 20. module 1 .

A series of optical fibre light guides 6 comprising within each light guide cable, at least one optical fibre as its core . Said core of each optical fibre light guide may be composed of a large number of small diameter optical fibres or be arranged as a smaller number of larger diameter optical fibres as the core arrangement.

The array of optical fibre light guides may be run coaxially adjacent to each other to form a bunched cable as the light radiation transport means. Cable may incorporate a coaxial cooling liquid line connected to a heat exchanger/circulator means.

30. An array of specifically placed optical receptor terminals 14 located within the confines of liquid filled compartment 15 are specifically positioned at the focal point⁴ of the optical focusing lens array 2.

Array of light beam receptor terminals 14 have connectable means¹⁸ to couple optical fibre light guides 6, whereby proximal ends 17 of said light guides align optically with the window of the beam receptor terminals 14.

4.



5.

Optical concentrator/collector means 2 may be formed as an array of optical lens elements 46 . Said optical lens elements may be formed as convex focusing lenses figure 9 . Alternatively they may be formed as fresnel focusing lenses 49 figure 12.

Lens array may be formed as separate lens inserts, figure 10,11, or be comprised as an array of optical lens means formed as a single moulding, figure 8,9, from a material with optical properties.

Figure 13 shows a possible arrangement of the device of the invention wherein the optical fibre light guides 6 form into a bunched cable represented as the radiation transport means 7 terminating in the solar optic lamp means 31.

One or an array of luminescent diffuser means 10 are supported within housing 11 , figures 2,3,4,5 and 13, optically coupled to the distal ends 9 of the optical fibre light guides 6. Visible light rays 12 are shown emitting from lamp 31.

Solar optic lamp variations shown in figures 2,3 ,4, 5 and 6 may just as well be the terminating fittings attached to the light radiation transport means 7.

Solar optic lamp means 31 may be adjacently placed or located at a remote position to the sun tracking module 1. Solar optic lamps may employ a variety of light emission means such as solid luminescent diffusers formed as doped quartz or other forms and types of luminescent material in either solid or liquid form.

Figure 6 shows a solar optic lamp 31 as a radiation emitting device whereby the radiation energy conveyed by the radiation transport means 7 to the lamp emits from the distal ends 9 of the optical light guide means 6 aimed at the beam expanding means in the form of primary and secondary reflector means 36 and 37 .

Figure 12 shows a cutaway view in part section as a variation of the invention wherein the radiation concentrator/collector means function is performed by a series of fresnel lens 49 as the focusing means 2 in combination with a battery of frusto-conical reflectors 47 formed within and as part of the liquid filled compartment 15 of the sun tracking module. Focusing cavities 33 of frusto-conical reflectors have a reflective surface 32 to further concentrate radiation focusing means 2 of the lens element 46 which is formed as windows sealing the larger openings of the battery of frusto-conical reflectors. Solar radiation is concentrated to focal points 4 within the windows of the optical

5.



6.

receptor terminals 14 wherein the proximal ends 17 of the optical fibre light guides 6 are connectably located, being optically ^{connected} through the light refractive transparent liquid coolant to filter radiation received by optical receptor terminals. A series of passages allows circulation of liquid through collector/concentrator cavities to provide the cooling and optical filtering means.

Reference list to indexing shown in the drawings follows, relating to the device of the invention and various selected arrangements and disclosed ways of using the art of the invention.

1. sun tracking module.
2. optical concentrator/collector means as the focusing lens means.
10. 3. section of sun tracking component.
4. focal point of focusing lens.
5. cut-away view of housed components.
6. optical fibre light guide means.
7. light guide bunched cable as the radiation transport means.
8. incident solar radiation.
9. distal ends of optical fibre light guide means.
10. luminescent diffuser means.
11. housing body of solar optic lamp.
12. illumination rays.
20. 13. liquid conveying lines.
14. light beam receptor terminals.
15. liquid filled compartment.
16. focused converging radiation.
17. proximal ends of fibre optic light guide means.
18. circulating liquid .
20. luminescent diffuser bead.
29. secondary luminescent diffuser means.
31. solar optic lamp.
32. reflective means.
30. 33. focusing cavity, -filled with transparent ^{light} refractive liquid.
35. secondary reflected rays. liquid.
36. secondary beam expanding reflector means.
37. primary beam expanding ~~reflector~~ means.

6.



7.

- 42. conveyed radiation energy.
- 44 multi-lens array housing.
- 45. multi-lens fabricated panel.
- 46. optical lens element.
- 47. frustro-conical reflector focusing means.
- 48. optical fibre light guide connectable means.
- 49. fr^esnel lens focusing means.
- 52. fibre optic bunched cable as the radiation transport means incorporating a liquid coolant line.
- 10. 53. said coolant line for 52.

To those skilled in the art to which this invention relates; many changes in construction, design and widely differing embodiments and applications of the invention will suggest themselves without departing from the spirit and scope of the invention. The disclosures and description herein, are purely illustrative and are not intended to be in any sense limiting or being restricted to a precise form.

A.G. YARRINGTON.

7.



8.

ABSTRACT.

TITLE.

A sun tracking module 1 as an apparatus incorporating a concentrator/collector means connecting to an optical light guide means 6 as the radiation transport means 7. Solar radiation energy 8 is conveyed to adjacent or remote solar optic lamps 31.

Said sun tracking module 1 houses a liquid filled compartment 15 wherein an array of optical lens elements 46 formed as the window of the upper wall of said liquid filled compartment 15 identified as the optical focusing means 2 functions as the optical concentrator/collector means 2.

Said optical focusing means concentrates solar incident radiation as a focused converging radiation 16 passing through transparent refractive liquid contained in the liquid filled compartment 15 to enter window of optical beam receptor terminals 14 located at the focal point 4.

Said optical beam receptor terminals 14 house the proximal ends 17 of the optical fibre light guides 6 attached by a connectable means 48.

8.



THE CLAIMS DEFINING THE INVENTION ARE AS FOLLOWS:

1. A sun tracking module comprising :

[a] a liquid filled compartment housed as a component of the sun tracking module,

-having upper wall and a base side , said liquid filled compartment
- having inlet and outlet liquid lines connecting to an adjacently placed circulator/heat exchanger means, and said liquid filled compartments upper wall formed as

[b] a window consisting of an array of optical focusing lens means formed as the optical concentrator/collector means , which optically couple to

[c] a series of specifically placed optical receptor terminals located in the base side of said liquid filled compartment , being optically aligned to the focal points of said optical focusing lens means, said series of specifically placed optical receptor terminals,
- having connectable means to attach the proximal ends of the optical fibre light guide means forming the radiation transport means to channel light radiation energy to recipient devices, and

[d] a light refractive transparent liquid circulating within said liquid filled compartment whereby said transparent refractive liquid forms a filter across the optical focusing path of the optical focusing lens means.

2. A sun tracking module comprising :

[a] a liquid filled compartment housed as a component of the sun tracking module,

- having a upper wall and a base side , said liquid filled compartment
- having inlet and outlet liquid lines connecting to an adjacently placed circulator/heat exchanger means, and said liquid filled compartments upper wall formed as

[b] a window consisting of an array of optical focusing lens means, said array of optical focusing lens means sealing the larger openings of a battery of frustro-conical reflectors formed within and as part of the liquid filled compartment, said array of optical focusing lens means combined with the said battery of frustro-conical reflectors are formed as the optical concentrator/collector means, which optically



couple to

[c] a series of specifically placed optical receptor terminals located in the base side of said liquid filled compartment, being optically aligned to the focal points of said optical focusing lens means, said series of specifically placed optical receptor terminals - having connectable means to attach the proximal ends of the optical fibre light guide means forming the radiation transport means to channel light radiation energy to recipient devices, and

[d] a light refractive transparent liquid circulating within said liquid filled compartment whereby said transparent refractive liquid forms a filter across the optical focusing path of the optical focusing lens means.



3. A suntracking module as claimed in claim 1 and 2 wherein said optical fibre light guide means are composed of at least one optical fibre attaching to each optical receptor terminal, and said
- light radiation transport means to channel light radiation energy to remote radiation recipient devices related to the use of this energy.

4. A sun tracking module as claimed in claim 1 and 2 wherein said liquid filled compartment has inlet and outlet adaptors connected to liquid conveying lines which join to adjacent circulator/heat exchanger means.

5. A sun tracking module as claimed in claims 1 and 2 wherein the array of optical focusing lens means are comprised as an optical concentrator device.

6. A optical concentrator device as claimed in claim 5 wherein said optical concentrator device is in the form of an array of convex focusing lenses.

7. A optical concentrator device as claimed in claims 2 and 5 wherein said optical concentrator device is in the form of an array of fresnel lens focusing means.

8. An optical concentrator device as claimed in claim 5 wherein said optical concentrator device is composed as an array of optical lense means formed as a single moulding from material with optical properties.

9. A sun tracking module as claimed in claims 1 and 2 wherein the said sun tracking module is combined with a light radiation transport means to convey light radiation to recipient devices having at least one luminescent diffuser means as the light emitting element.

A.G. YARRINGTON

22nd Jan. 1991.

A.G. Yarrington



13849/88

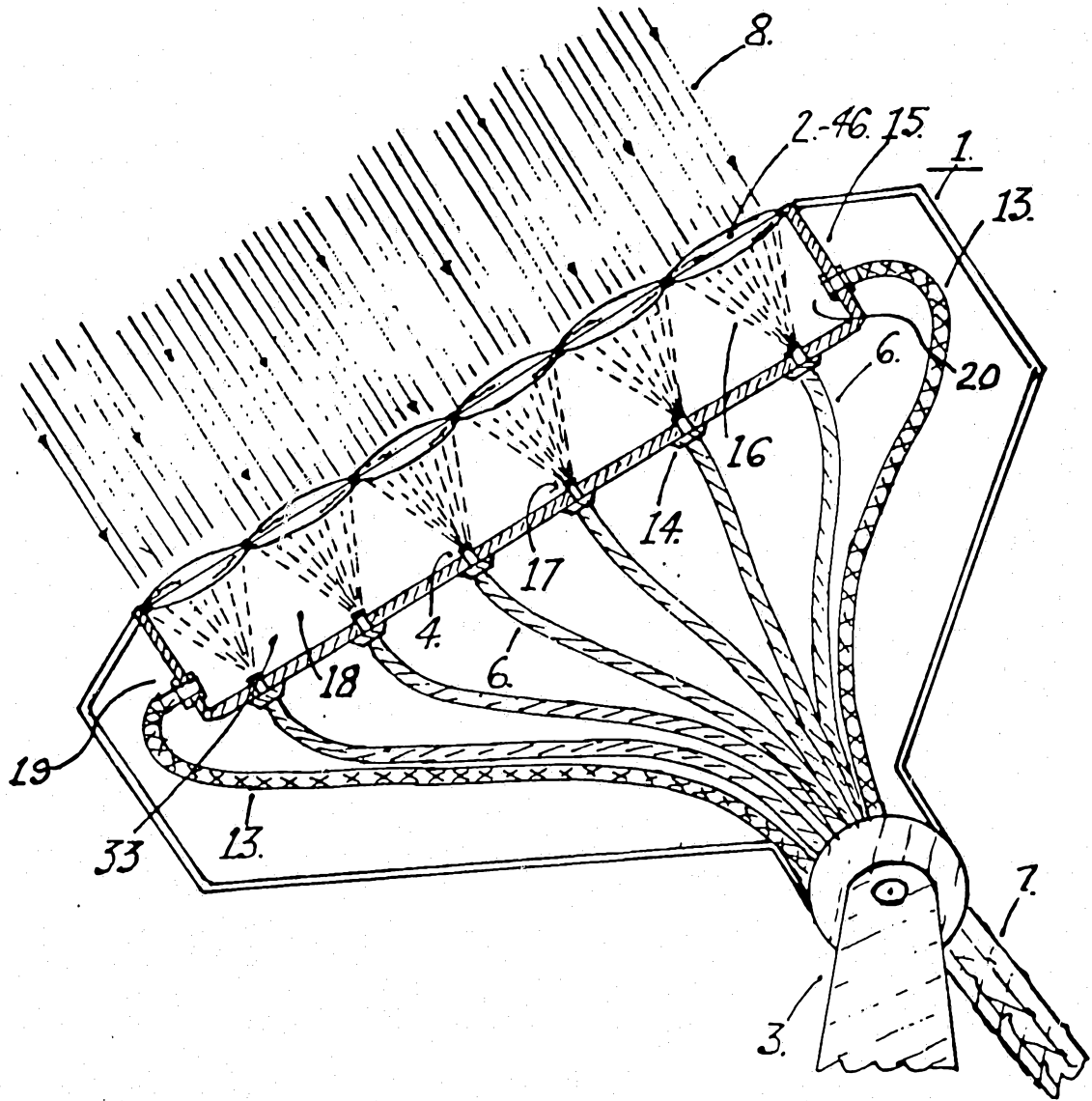

Fig 1.

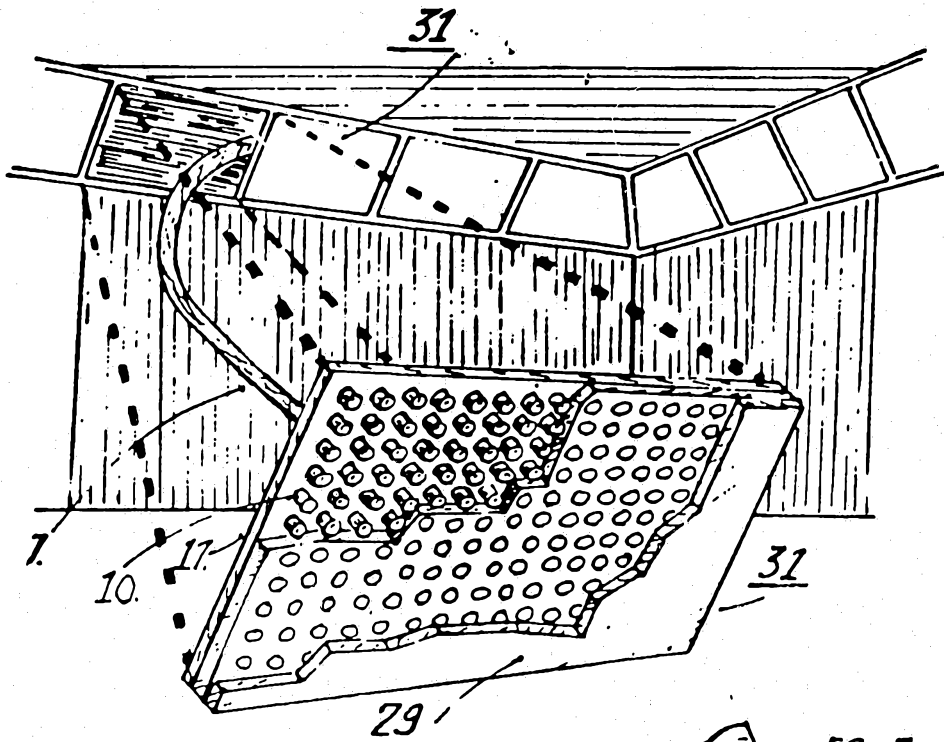

Fig. 2.

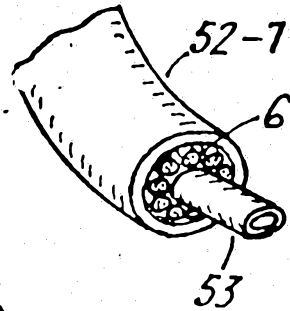

FIG 15.

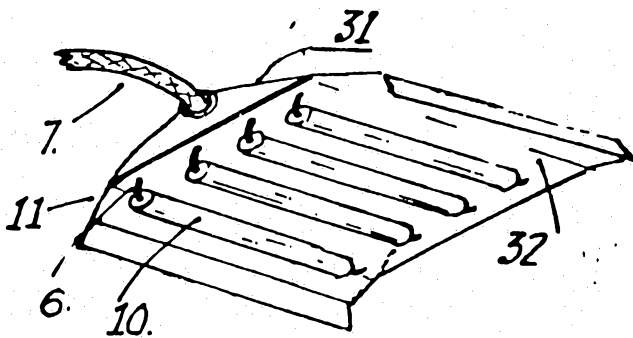

Fig. 3.

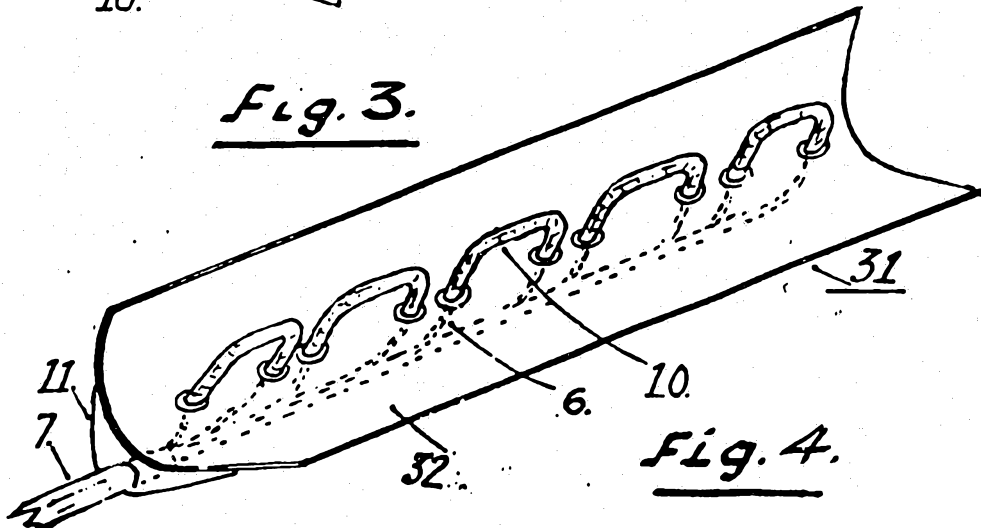

Fig. 4.

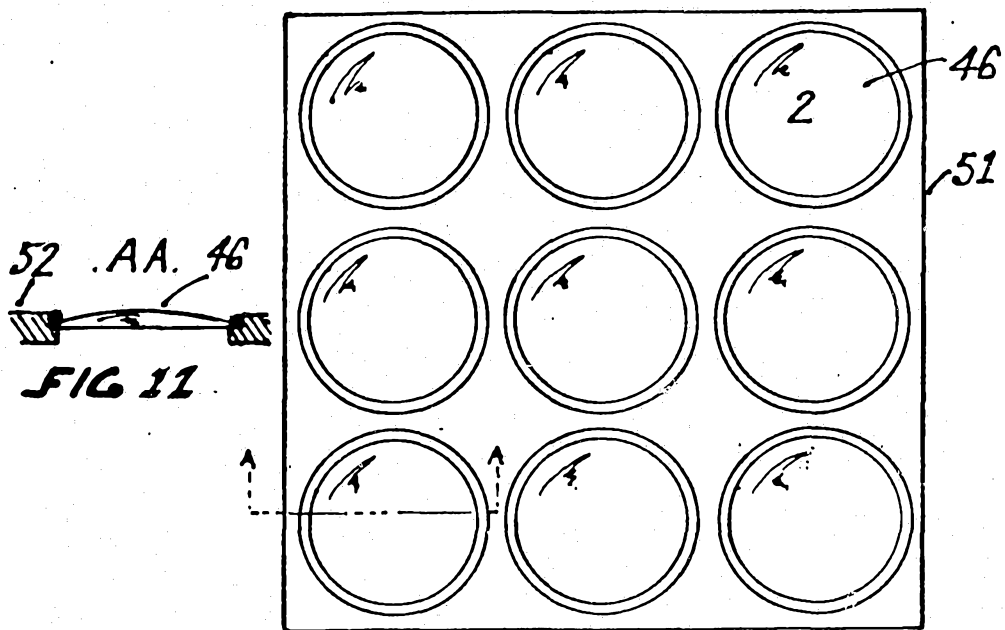

FIG 11.

FIG 10.

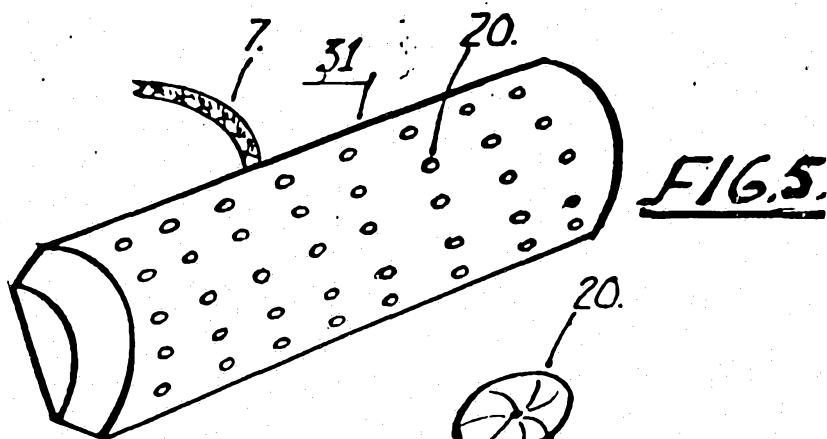

FIG 5.

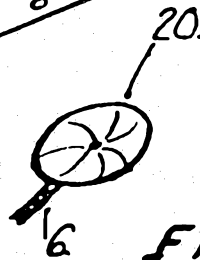

FIG 5A.

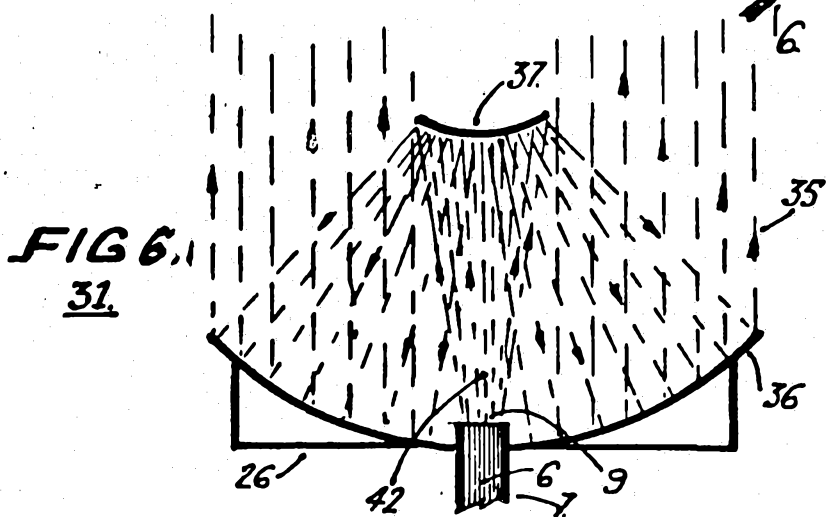

FIG 6.
31.

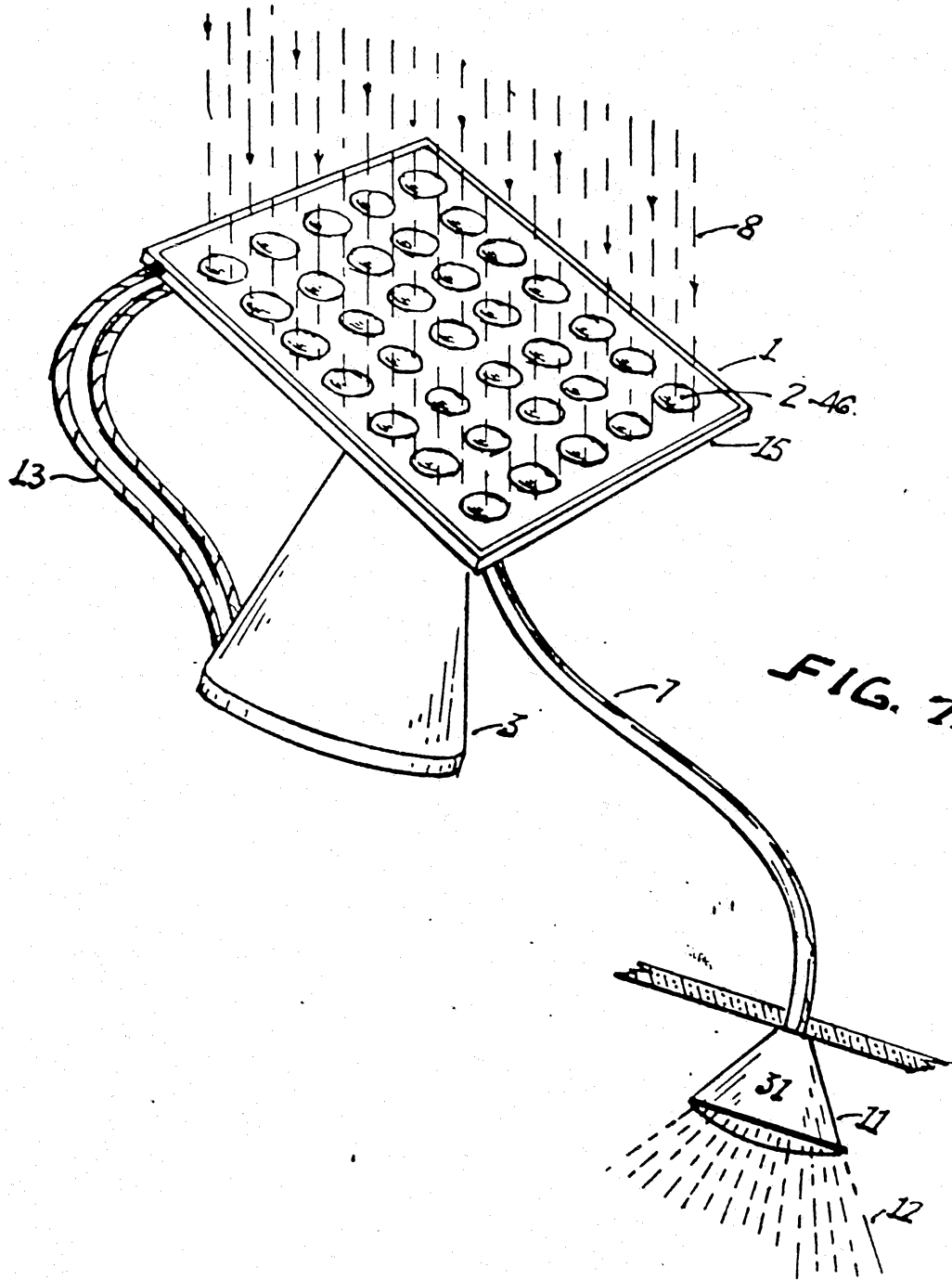

FIG. 7.

11 12 13 14 15 16 17 18 19 20 21 22 23 24 25 26 27 28 29 30 31 32 33 34 35 36 37 38 39 40 41 42 43 44 45 46 47 48 49 50 51 52 53 54 55 56 57 58 59 60 61 62 63 64 65 66 67 68 69 70 71 72 73 74 75 76 77 78 79 80 81 82 83 84 85 86 87 88 89 90 91 92 93 94 95 96 97 98 99 100

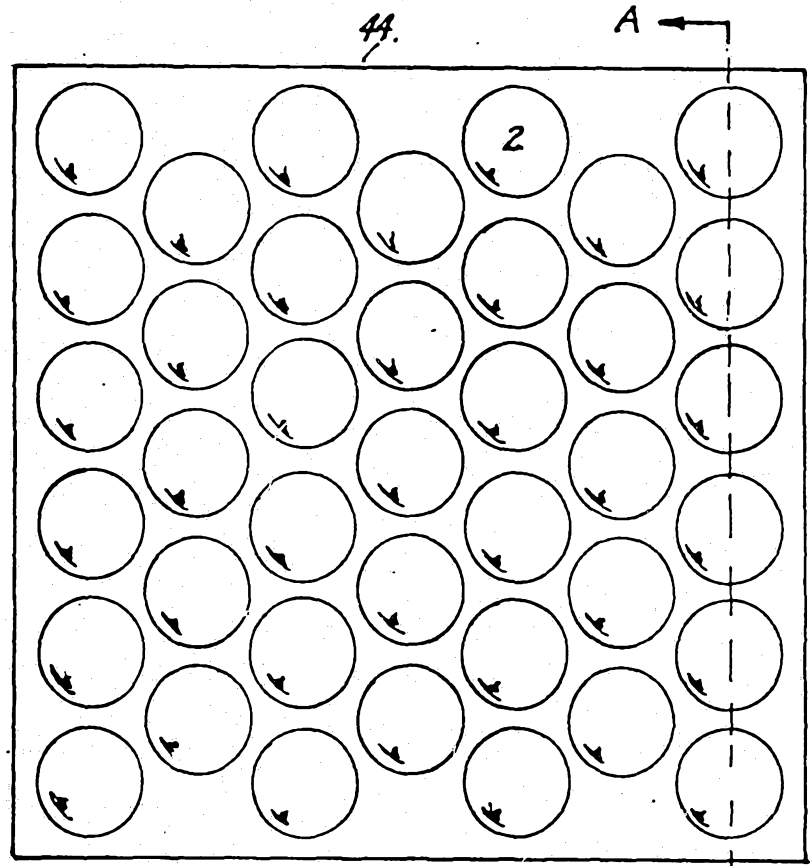

FIG. 8.

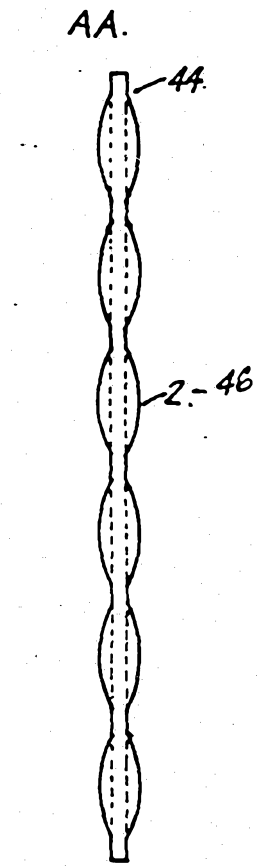

FIG. 9.

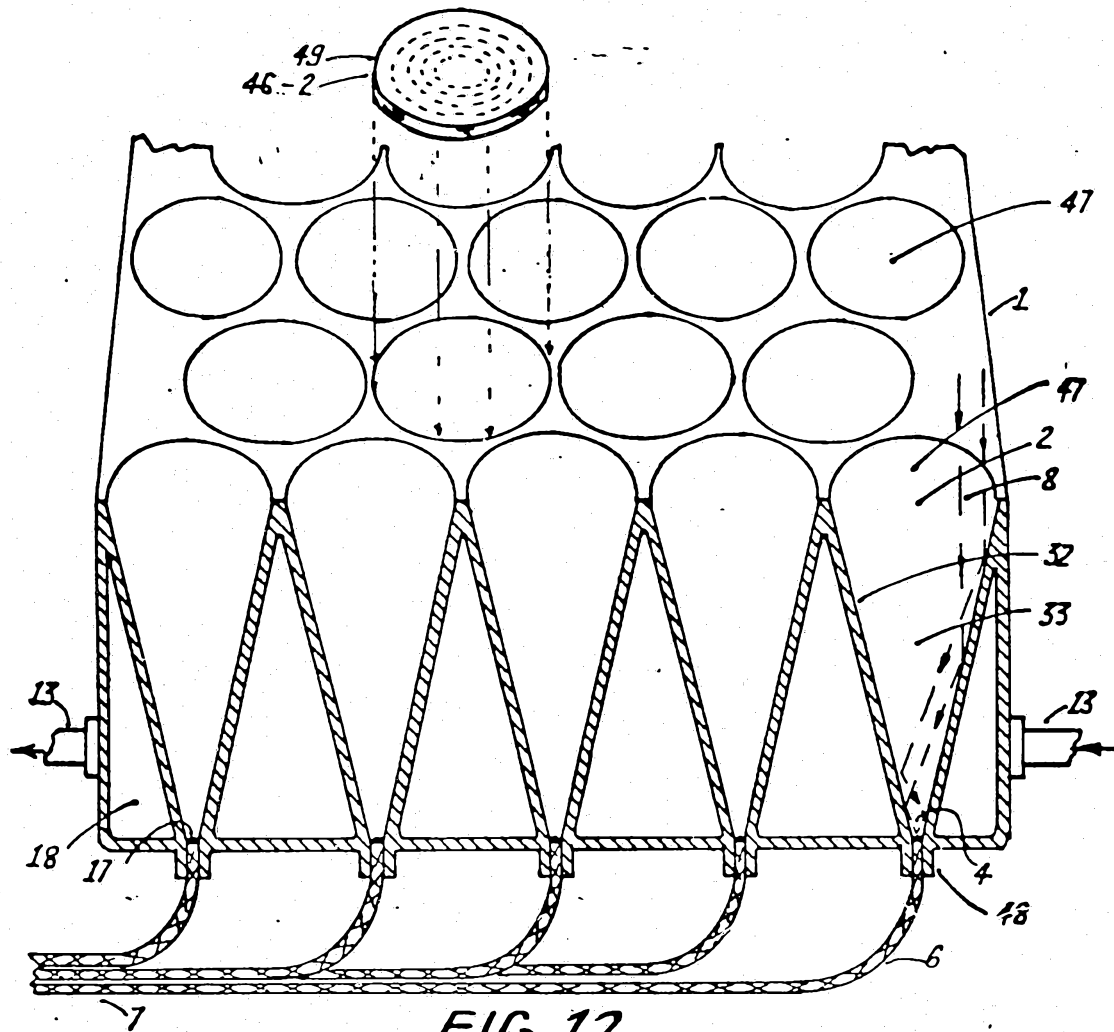

FIG 12.

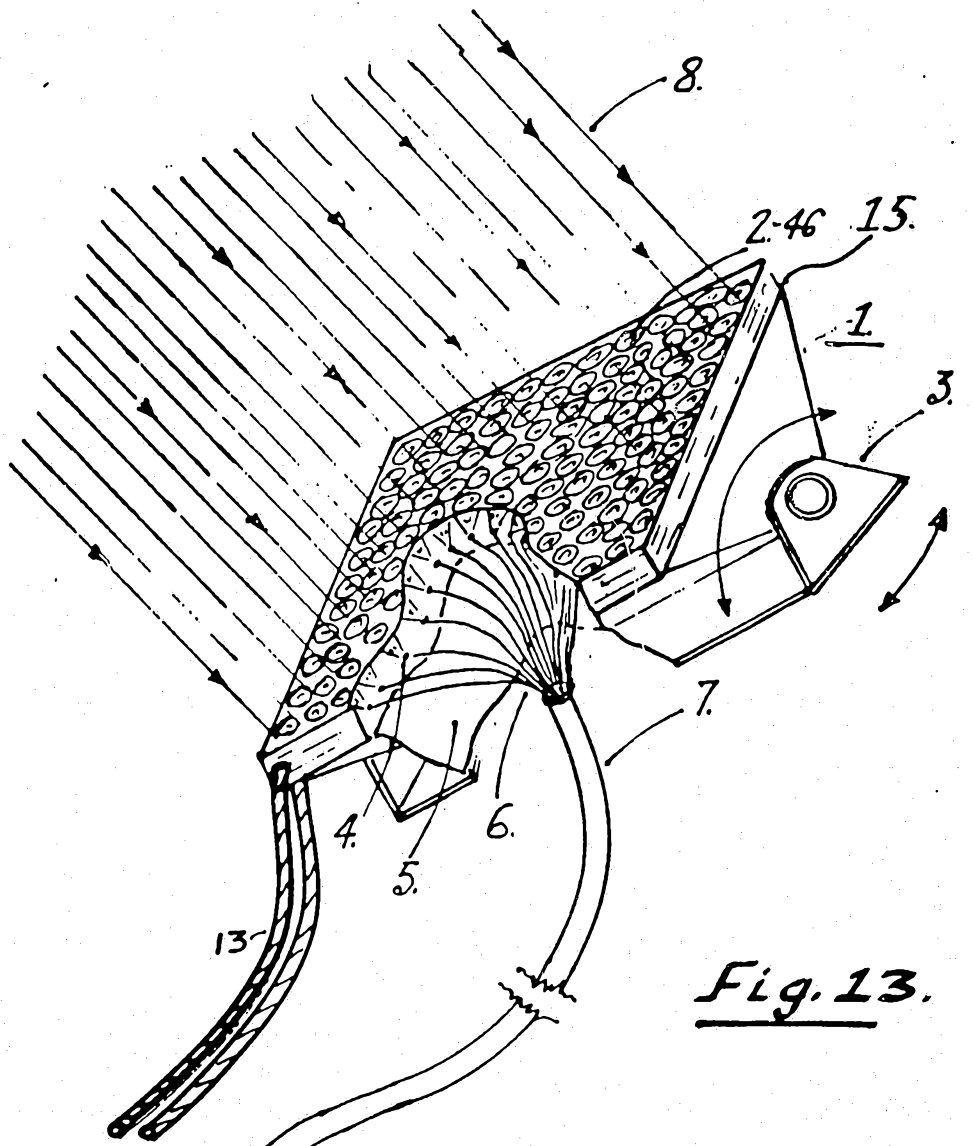

Fig. 13.

