

(12) PATENT
(19) AUSTRALIAN PATENT OFFICE

(11) Application No. AU 200013710 B2
(10) Patent No. 770059

(54) Title
Resorbable bone plate

(51) ⁶ International Patent Classification(s)
A61B 017/80

(21) Application No: 200013710

(22) Application Date: 1999.12.06

(87) WIPO No: W001/41663

(43) Publication Date : 2001.06.18

(43) Publication Journal Date : 2001.08.30

(44) Accepted Journal Date : 2004.02.12

(71) Applicant(s)
Synthes AG Chur

(72) Inventor(s)
Raymond Curtis; Markus Hehli

(74) Agent/Attorney
PHILLIPS ORMONDE and FITZPATRICK, 367 Collins Street, MELBOURNE
VIC 3000

(56) Related Art
EP 530585
JP 5-003883

AU 200013710

(12) INTERNATIONAL APPLICATION PUBLISHED UNDER THE PATENT COOPERATION TREATY (PCT)

(19) World Intellectual Property Organization
International Bureau



(43) International Publication Date
14 June 2001 (14.06.2001)

PCT

(10) International Publication Number
WO 01/41663 A1

- (51) International Patent Classification: A61B 17/80 [GB/CH]; B6rjistrasse 28, CH-7260 Davos (CH). HEHLI, Markus [CH/CH]; Haus Lusi, CH-7276 Davos (CH).
- (21) International Application Number: PCT/CH99/00582
- (22) International Filing Date: 6 December 1999 (06.12.1999)
- (23) Filing Language: English
- (24) Publication Language: English
- (71) Applicant (for all designated States except CA, US): SYNTHES AG CHUR [CH/CH]; Grabenstrasse 15, CH-7002 Chur (CH).
- (74) Agent: LUSUARDI, Werther; Dr. Lusuardi AG, Kreuzbühlstrasse 8, CH-8008 Zürich (CH).
- (81) Designated States (national): AU, CA, JP, NZ, US, ZA.
- (84) Designated States (regional): European patent (AT, BE, CH, CY, DE, DK, ES, FI, FR, GB, GR, IE, IT, LU, MC, NL, PT, SE).
- (71) Applicant (for CA only): SYNTHES (U.S.A.) [US/US]; 1690 Russell Road, P.O. Box 1766, Paoli, PA 19301-1222 (US).
- Published: — With international search report.
- (72) Inventors; and
- (75) Inventors/Applicants (for US only): CURTIS, Raymond
- For two-letter codes and other abbreviations, refer to the "Guidance Notes on Codes and Abbreviations" appearing at the beginning of each regular issue of the PCT Gazette.

(54) Title: RESORBABLE BONE PLATE

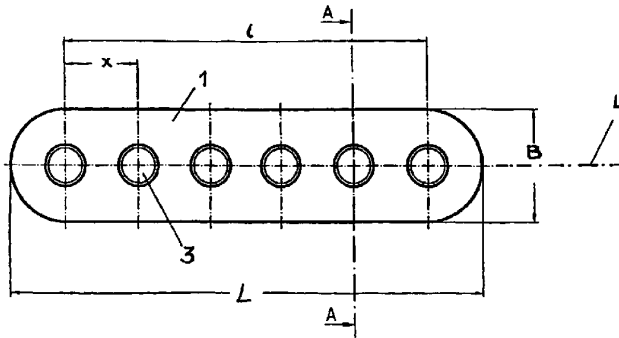

(57) Abstract: The bone plate of longitudinal shape has an upper surface (1), a curved lower surface (2) for contacting a bone, a plurality of conical through holes (3) connecting the upper surface (1) with the lower surface (2) for receiving bone screws, a central longitudinal axis (4) and consists of a resorbable material. The curved lower surface (2) has a radius of curvature R which is smaller than 10 mm. The ratio F/d of the total area F of the upper surface (1) including the surface area of the through holes (3) to the thickness d of the plate is in the range of 190 to 270 mm. The central part of the longitudinal plate has a generally constant width B whereas the width of the free ends of the longitudinal plate is narrowing to value $b < 0.3 B$. The resorbable bone plate overcomes the problems of adherence of soft-tissue. Its shape and function is optimized given the limitations of the properties of these materials.



WO 01/41663 A1

Resorbable bone plate

This invention concerns a bone plate.

Bone plates made of titanium have shown that this material has such a biocompatibility that soft-tissue is adhering thereto which can be in certain situation an undesirable property for bone plates. On the other hand bone plates made of bioresorbable materials usually have insufficient mechanical properties (eg. stiffness).

The present invention aims at overcoming the problems of adherence of soft-tissue and to optimise shape and function of an resorbable plate given the limitations of the properties of these materials.

Broadly, the present invention provides a bone plate of longitudinal shape having an upper surface, a curved lower surface for contacting a bone, a plurality of conical through holes connecting the upper surface with the lower surface for receiving bone screws, a central longitudinal axis and consisting of resorbable material, wherein:

the curved lower surface has a radius of curvature R which is smaller than 10 mm;

the ratio F/d of the total area F of the upper surface including the surface area of the through holes to the thickness d of the plate is in the range of 190 to 270 mm; and

1a

the central part of the longitudinal plate has a generally constant width B whereas the width of the free ends of the longitudinal plate narrows to value $b < 0,3 B$.

Resorbable materials to be used for the device according to the invention can be resorbable polymers like highly purified polyhydroxyacids, polysaccharides, polyamines, polyaminoacids, polyorthoesters, polyanhydrides, polyamidoesters, polydioxanone,

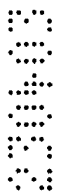
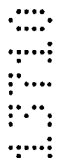

W:\Georg\IPWG Spec\665649.doc

polyesteramides, copolyoxalates, polycarbonates or poly-(glutamic-co-leucine). Preferably polylactides are used or their combinations with polyhydroxybutyrates or polyhydroxyvalerates and/or resorbable glasses.

Other useful polyhydroxyacids comprise polycaprolactone, poly(L-lactide), poly(DL-lactide), polyglycolide, poly-(DL-lactide-co-glycolide), poly(DL-lactide-co-caprolactone).

Preferably the lower surface of the bone plate has a radius of curvature R which is smaller than 9 mm. The axis of the hollow cylinder corresponding to the curved plate is running parallel to the central longitudinal axis of the plate.

The ratio F/d of the total area F of the upper surface (including the surface area of the through holes) to the thickness d of the plate is in the range of 210 to 240 mm. Preferably the ratio F/f of the total area F of the upper surface (including the surface area of the through holes) to the true surface f of the upper surface (excluding the surface area of the through holes) is in the range of 1,10 - 1,25.

The width of the free ends of the longitudinal plate is narrowing to value b being preferably smaller than 0,15 B .

The upper surface of the bone plate has preferably a roughness of 0,5 μm to 5,0 μm , typically of 0,6 μm to 2,5 μm .

in order to avoid the adherence of soft tissue after implantation. In any case it is preferred that the upper surface is smoother than the lower surface.

5 Preferably the bone plate is provided with a torsion around its central longitudinal axis which allows application to the required bone profile. The degree of torsion of the bone plate is preferably between $\pm 1^\circ$ to $\pm 20^\circ$ over the total length.

10 The length l of the central part of the longitudinal plate corresponds preferably to 73 – 82% of the total length L of the plate.

15 In order to achieve better angular stability selected or all of the conical through holes may be provided with a thread. However, it is also possible to use through holes with a smooth inner surface.

The through holes have preferably a cone angle of 15° to 25° , typically of 18° to 22° .

20 The bone plate is provided preferably with $n \geq 4$ holes (more preferably with $n \geq 6$ holes), whereby the two most centrally located holes have preferably a distance which is at least 102%, preferably 150% to 180% of the distance x between the other through holes. When the central part of the plate is reinforced by

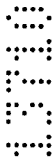

omitting the most central hole (or holes) maximum rigidity of the cross section is obtained which is important for the bridging of bone defects.

The various features of novelty which characterize the invention are pointed out with particularity in the claims annexed to and forming part of this disclosure. For the better understanding of the invention, its operating advantages and specific objects attained by its use, reference should be had to the accompanying drawings, examples and descriptive matter in which are illustrated and described preferred embodiments of the invention.

In the drawings:

Fig. 1 is a view in elevation of the bone plate according to the invention; and

Fig. 2 is a section along line A-A of Fig. 1;

Figure 1 shows a bone plate of longitudinal shape having an upper curved surface 1, a curved lower surface 2 for contacting a long bone, e.g. a metacarpal bone, six conical through holes 3 connecting the upper surface 1 with the lower surface 2 for receiving bone screws and a central longitudinal axis 4.

The through holes 3 have a cone angle of 20° and a minimum diameter D of 2,8 mm located at the lower side 2.

The lower surface 2 has a radius of curvature R of 7 mm. The plate consists of polylactide copolymer with an enhanced degradation rate.

The ratio F/d of the total area F of the upper surface 1 (including the surface area of the through holes 3) to the thickness d of the plate has the value of 223 mm.

The ratio F/f of the total area F of the upper surface 1 including the surface area of the through holes 3 to the true surface f of the upper surface 1 excluding the surface area of the through holes 3 has the value of 1,17.

The central part of the longitudinal plate (over the length l in Fig. 1) has a constant width B whereas the width of the free ends of the longitudinal plate is narrowing gradually to value 0 in the form of a hemi-circle. The length l of the central part of the longitudinal plate corresponds to 77 % of the total length L of the plate.

THE CLAIMS DEFINING THE INVENTION ARE AS FOLLOWS:

1. Bone plate of longitudinal shape having an upper surface, a curved lower surface for contacting a bone, a plurality of conical through holes connecting the upper surface with the lower surface for receiving bone screws, a central longitudinal axis and consisting of resorbable material, wherein:

the curved lower surface has a radius of curvature R which is smaller than 10 mm;

the ratio F/d of the total area F of the upper surface including the surface area of the through holes to the thickness d of the plate is in the range of 190 to 270 mm; and

the central part of the longitudinal plate has a generally constant width B whereas the width of the free ends of the longitudinal plate narrows to value $b < 0.3 B$.



2. Bone plate according to claim 1, wherein the radius of curvature R is smaller than 9 mm.

3. Bone plate according to claim 1 or 2, wherein the ratio F/d is in the range of 210 to 240 mm.

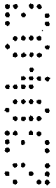

4. Bone plate according to any one of claims 1 to 3, wherein the ratio F/f of the total area F of the upper surface including the surface area of the through holes to the true surface area f of the upper surface excluding the surface area of the through holes is in the range of 1.10-1.25.

W:\Georgel\PIWG Spec\1605649.doc

5. Bone plate according to any one of claims 1 to 4, wherein the width of the free ends of the longitudinal plate narrows to value $b < 0.15 B$.
6. Bone plate according to any one of claims 1 to 5, wherein the upper surface has a roughness of $0.5 \mu\text{m}$ to $5.0 \mu\text{m}$.
7. Bone plate according to any one of claims 1 to 6, wherein the upper surface is smoother than the lower surface.
8. Bone plate according to any one of claims 1 to 6, wherein plate is provided with a torsion around its central longitudinal axis.
9. Bone plate according to any one of claims 1 to 8, wherein the length l of the central part of the longitudinal plate corresponds to 73-82 % of the total length L of the plate.
10. Bone plate according to any one of claims 1 to 9, wherein conical through holes are provided with a thread.
11. Bone plate according to any one of claims 1 to 9, wherein conical through holes have smooth inner surface.
12. Bone plate according to any one of claims 1 to 11, wherein it is provided with $n \geq 4$ holes, and wherein the two most centrally located holes have a distance which is at least 102%, of the distance x between the other holes.

13. Bone plate according to any one of claims 1 to 12, wherein the through holes have a cone angle of 15° to 25°.

14. Bone plate substantially as herein described with reference to the accompanying drawings.

DATED: 19 November 2003

PHILLIPS ORMONDE & FITZPATRICK

Attorneys for:

SYNTHES AG CHUR

PHILLIPS
ORMONDE
&
FITZPATRICK

PHILLIPS
ORMONDE
&
FITZPATRICK

W:\MaryOIBFSPeoh13710-00.doc

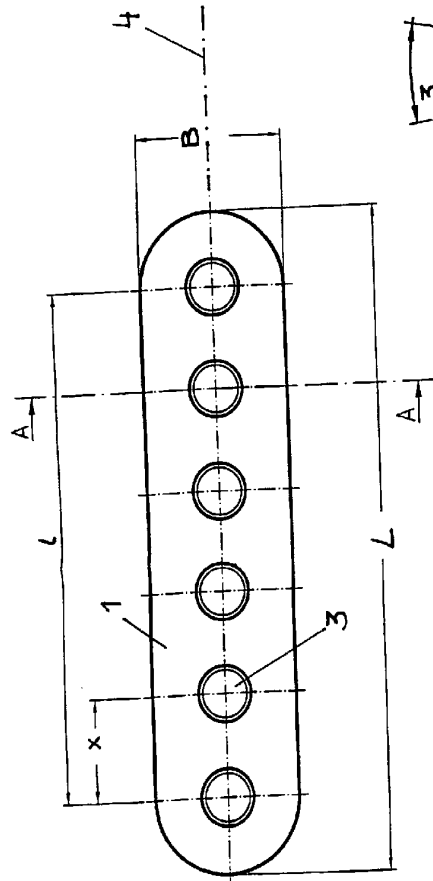

Fig. 1

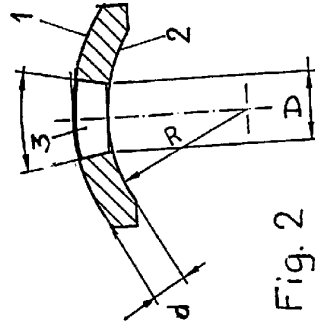

Fig. 2

A - A