

D. R. WILLIAMS, Sr.
 Improvement in Scroll-Sawing Machines.
 No. 130,680.

Patented Aug 20, 1872.

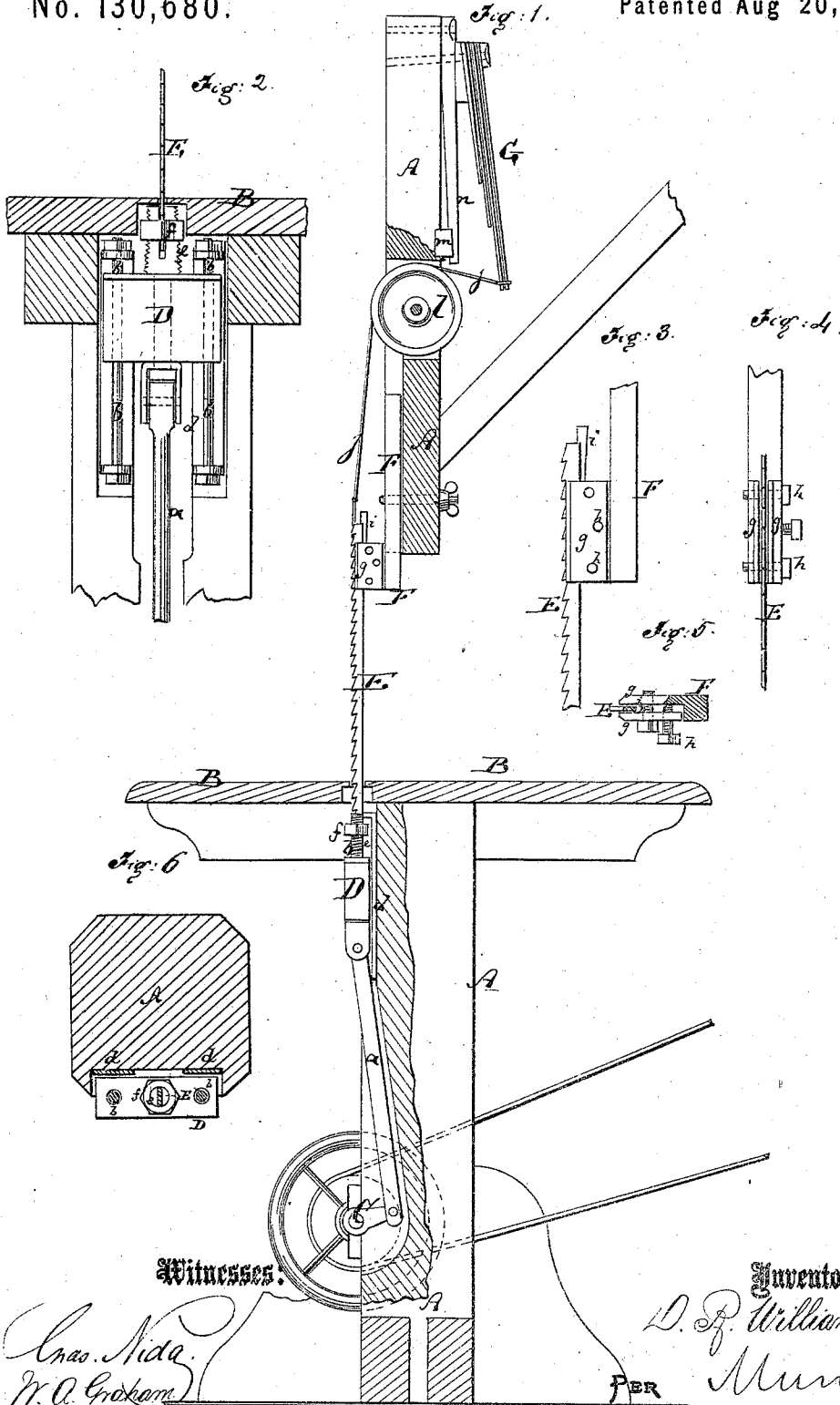

Witnesses:

Chas. Nida.
W. A. Graham.

Inventor:

D. R. Williams Sr.

Munn & Co.

Attorneys.

UNITED STATES PATENT OFFICE.

DAVID R. WILLIAMS, SR., OF PARIS, KENTUCKY.

IMPROVEMENT IN SCROLL-SAWING MACHINES.

Specification forming part of Letters Patent No. 130,680, dated August 20, 1872.

Specification describing a new Improvement in Scroll-Sawing Machines, invented by DAVID R. WILLIAMS, Sr., of Paris, in the county of Bourbon and State of Kentucky.

In the accompanying drawing, Figure 1 represents a sectional elevation of my improved scroll-sawing machine. Fig. 2 is a front view of the cross-head and guide; Fig. 3 a side view, Fig. 4 a front view, and Fig. 5 a horizontal section, of the guide-foot; and Fig. 6, a top view of the cross-head.

Similar letters of reference indicate corresponding parts.

This invention relates to improvements in the arrangement of the cross-head, guide-foot, and tension apparatus of a scroll-saw, with the object of facilitating the application and adjustment of the saw and of keeping all strain from the guide-rods. The invention consists in an improved mode of combining guide-rods and a bearing-plate with a saw cross-head, so that the cross-head will not have the friction of the bearing-plate, except when pressed thereagainst by the work; and it also consists in providing a clamp, which holds the saw, with an adjustable pin that will afford a rest thereto when the width is lessened by wear or sharpening.

A in the drawing represents the frame-work of the sawing-machine, carrying the table B and, below the table, the operating-shaft C, which is revolved by suitable power. The pitman *a* from the crank of the shaft C connects with the cross-head D, to which the lower end of the saw-blade E is secured. The cross-head embraces two vertical rods, *b b*, on which it slides up and down, said rods constituting its guides. Directly behind the cross-head is secured to the frame A a plate, *d*, with a polished surface, close to which the cross-head reciprocates. Whenever the saw is slightly crowded back by the work the cross-head will come in contact with the bed-plate *d*, which takes the strain. The rods *b b* are then liberated from all strain, and will, therefore, not be bent out of shape. The rods *b b* are of steel, and polished to let the cross-head move easily. From the upper edge of the cross-head projects a tapering pin, *e*, which

has a screw-thread cut around it, and is split. A nut, *f*, embraces this pin *e*. The lower end of the saw-blade E is fitted into the slit of the pin *e*, and then drawn tight by means of the nut *f*, as indicated in Fig. 2. This mode of fastening the saw is very simple and effective, and allows of the speedy removal and insertion of the saw. The upper end of the saw-blade E is fitted between two projecting cheek-plates, *g g*, of the guide-foot F. The latter is properly held in a groove of the upper part of the frame-work A. The cheeks *g g* can be set more or less together or apart to suit the thickness of saw-blade, by means of screws *h h*. A pin, *i*, is interposed between the cheeks *g* directly behind the saw-blade, and set forward as the saw becomes reduced in width by filing. The saw can thus be so set that only its teeth and no unnecessary portion of its blade projects from in front of the cheeks *g*. G is a wooden spring applied to the upper part of the frame-work A, and connected at its lower end by means of a string, *j*, passing over a friction-roller, *l*, with the upper end of the saw-blade, keeping the same in tension whenever it is desired so to do. I prefer, however, to leave the saw without this tension, except for cutting very heavy work. When the strength of the spring G is to be increased or reduced a slide or sliding wedge, *m*, can be moved up or down between the spring or its holder *n* and the frame A.

Having thus described my invention, I claim as new and desire to secure by Letters Patent—

1. The guide-rods *b b* and fixed plate *d* combined with a cross-head, D, and allowing the latter to slide always independently on said guide-rods, except when the saw is crowded back by the work, as and for the purpose set forth.

2. The pin *i*, adjustable between the cheek-plates *g g* of guide-foot, as and for the purpose set forth.

DAVID R. WILLIAMS, SR.

Witnesses:

ISAAC CUNNINGHAM,
H. C. HASTINGS.