



- (51) International Patent Classification:
F01D 5/14 (2006.01)
- (21) International Application Number:
PCT/US2014/052293
- (22) International Filing Date:
22 August 2014 (22.08.2014)
- (25) Filing Language: English
- (26) Publication Language: English
- (30) Priority Data:
61/941,815 19 February 2014 (19.02.2014) US
- (71) Applicant: UNITED TECHNOLOGIES CORPORATION [US/US]; One Financial Plaza, Hartford, Connecticut 06101 (US).
- (72) Inventors: GALLAGHER, Edward J.; 26 Brookline Drive, West Hartford, Connecticut 06107 (US). MONZON, Byron R.; 1 Debra Ct., Cromwell, Connecticut 06416 (US). LIU, Ling; 43 Mallard Drive, Glastonbury, Connecticut 06033 (US). LI, Linda S.; 10 Edgewood Court Ext., Middlefield, Connecticut 06455 (US). WHITLOW, Darryl; 149 Dove Lane, Middletown, Connecticut 06457 (US). FORD, Barry M.; 123 Greenview Terrace, Middletown, Connecticut 06457 (US).
- (74) Agent: GOTTSCHALK, William, S.; Carlson, Gaskey & Olds, P.C./Pratt & Whitney, 400 W. Maple, Suite 350, Birmingham, MI 48009 (US).
- (81) Designated States (unless otherwise indicated, for every kind of national protection available): AE, AG, AL, AM, AO, AT, AU, AZ, BA, BB, BG, BH, BN, BR, BW, BY, BZ, CA, CH, CL, CN, CO, CR, CU, CZ, DE, DK, DM, DO, DZ, EC, EE, EG, ES, FI, GB, GD, GE, GH, GM, GT, HN, HR, HU, ID, IL, IN, IR, IS, JP, KE, KG, KN, KP, KR, KZ, LA, LC, LK, LR, LS, LT, LU, LY, MA, MD, ME, MG, MK, MN, MW, MX, MY, MZ, NA, NG, NI, NO, NZ, OM, PA, PE, PG, PH, PL, PT, QA, RO, RS, RU, RW, SA, SC, SD, SE, SG, SK, SL, SM, ST, SV, SY, TH, TJ, TM, TN, TR, TT, TZ, UA, UG, US, UZ, VC, VN, ZA, ZM, ZW.
- (84) Designated States (unless otherwise indicated, for every kind of regional protection available): ARIPO (BW, GH, GM, KE, LR, LS, MW, MZ, NA, RW, SD, SL, ST, SZ, TZ, UG, ZM, ZW), Eurasian (AM, AZ, BY, KG, KZ, RU, TJ, TM), European (AL, AT, BE, BG, CH, CY, CZ, DE, DK, EE, ES, FI, FR, GB, GR, HR, HU, IE, IS, IT, LT, LU, LV, MC, MK, MT, NL, NO, PL, PT, RO, RS, SE, SI, SK, SM, TR), OAPI (BF, BJ, CF, CG, CI, CM, GA, GN, GQ, GW, KM, ML, MR, NE, SN, TD, TG).

Published:

— with international search report (Art. 21(3))

(54) Title: GAS TURBINE ENGINE AIRFOIL

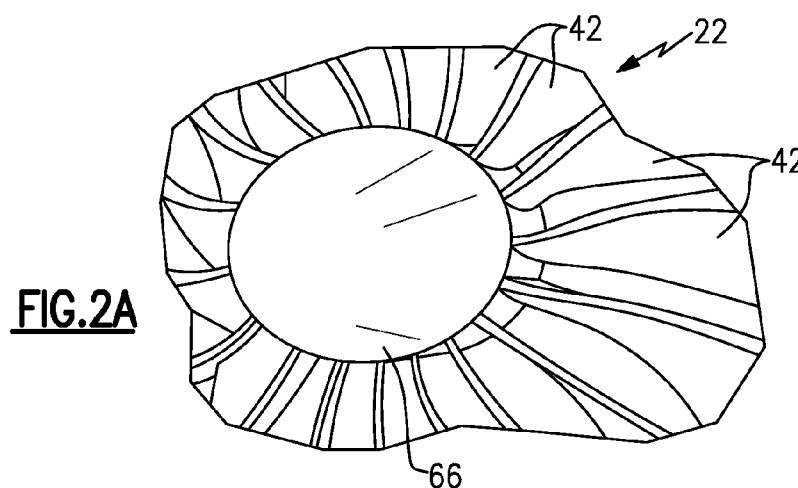
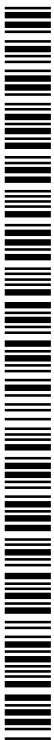

FIG. 2A

(57) Abstract: An airfoil for a turbine engine includes pressure and suction sides extending in a radial direction from a 0% span position at an inner flow path location to a 100% span position at an airfoil tip. The airfoil has a relationship between an axial leading edge location and a span position that is at least a third order polynomial with a generally U-shaped curve having an initial negative slope followed by a positive slope. The positive slope leans aftward and the negative slope leans forward. The curve has a critical point in the range of 30-50% span position at which the curve changes from the negative slope to the positive slope. The curve is generally linear from 55% span to 75% span and has a positive slope that increases at a rate of about 0.0875 inch (2.22 mm) per 1% span, +/- 0.04 inch (1.01 mm) per 1% span.



GAS TURBINE ENGINE AIRFOIL

CROSS-REFERENCE TO RELATED APPLICATIONS

[0001] This application claims priority to United States Provisional Application No. 61/941,815, which was filed on February 19, 2014 and is incorporated herein by reference.

BACKGROUND

[0002] This disclosure relates generally to an airfoil for gas turbine engines, and more particularly to a fan or compressor blade and the relationship between the blade's leading and trailing edge axial positions relative to span.

[0003] A turbine engine such as a gas turbine engine typically includes a fan section, a compressor section, a combustor section and a turbine section. Air entering the compressor section is compressed and delivered into the combustor section where it is mixed with fuel and ignited to generate a high-speed exhaust gas flow. The high-speed exhaust gas flow expands through the turbine section to drive the compressor and the fan section. The compressor section typically includes low and high pressure compressors, and the turbine section includes low and high pressure turbines.

[0004] The propulsive efficiency of a gas turbine engine depends on many different factors, such as the design of the engine and the resulting performance debits on the fan that propels the engine. As an example, the fan may rotate at a high rate of speed such that air passes over the fan airfoils at transonic or supersonic speeds. The fast-moving air creates flow discontinuities or shocks that result in irreversible propulsive losses. Additionally, physical interaction between the fan and the air causes downstream turbulence and further losses. Although some basic principles behind such losses are understood, identifying and changing appropriate design factors to reduce such losses for a given engine architecture has proven to be a complex and elusive task.

SUMMARY

[0005] In one exemplary embodiment, an airfoil for a turbine engine includes pressure and suction sides extending in a radial direction from a 0% span position at an inner

flow path location to a 100% span position at an airfoil tip. The airfoil has a relationship between an axial leading edge location and a span position that is at least a third order polynomial with a generally U-shaped curve having an initial negative slope followed by a positive slope. The positive slope leans aftward and the negative slope leans forward. The curve has a critical point in the range of 30-50% span position at which the curve changes from the negative slope to the positive slope. The curve is generally linear from 55% span to 75% span and has a positive slope that increases at a rate of about 0.0875 inch (2.22 mm) per 1% span, +/- 0.04 inch (1.01 mm) per 1% span.

[0006] In a further embodiment of the above, the curve has at least one inflection point.

[0007] In a further embodiment of any of the above, the airfoil extends from a root. A zero axial leading edge location corresponds to the axial center of the root.

[0008] In a further embodiment of any of the above, the critical point is in the range of 35-40% span position.

[0009] In a further embodiment of any of the above, a portion of the negative slope is substantially linear for 10-25% span of the airfoil up to about a 25% span position.

[0010] In a further embodiment of any of the above, a portion of the positive slope is substantially linear for 10-15% span of the airfoil and crosses over about a 65% span position.

[0011] In a further embodiment of any of the above, the positive slope crosses an initial axial leading edge location at the 0% span position at 60-80% span position.

[0012] In a further embodiment of any of the above, the initial axial leading edge location has a R_d/X_{LE} in a range of -7 to -9.

[0013] In a further embodiment of any of the above, the initial axial leading edge location has a R_d/X_{LE} in a range -6 to -8.

[0014] In a further embodiment of any of the above, the initial axial leading edge location has a R_d/X_{LE} in a range -6 to -7.

[0015] In a further embodiment of any of the above, the positive slope changes in a last 20% span of the airfoil.

[0016] In a further embodiment of any of the above, the airfoil is a fan blade for a gas turbine engine.

[0017] In a further embodiment of any of the above, the airfoil has a relationship between an axial trailing edge location and a span position that is at least a third order polynomial with at least one S-shaped curve having a negative slope ending at the 100% span position that is preceded by a positive slope. The positive slope leans aftward and the negative slope leans forward. The curve has a critical point in the range of 55-85% span position at which the curve changes from the positive slope to the negative slope.

[0018] In a further embodiment of any of the above, the curve has at least three inflection points.

[0019] In a further embodiment of any of the above, the airfoil extends from a root and a zero axial trailing edge location corresponds to axial center of the root.

[0020] In a further embodiment of any of the above, the critical point is in the range of 60-80% span position.

[0021] In a further embodiment of any of the above, the critical point has a R_d/X_{TE} in a range 7 to 8.

[0022] In a further embodiment of any of the above, the critical point has a R_d/X_{TE} in a range 7 to 8.

[0023] In a further embodiment of any of the above, the critical point has a R_d/X_{TE} in a range 5 to 7.

[0024] In a further embodiment of any of the above, the critical point is a second critical point, and the curve includes a first critical point is in the range of 25-45% span position. The positive slope extends from the first critical point to the second critical point.

[0025] In a further embodiment of any of the above, the first critical point has a R_d/X_{TE} in a range 8 to 10.

[0026] In a further embodiment of any of the above, the first critical point has a R_d/X_{TE} in a range 8 to 9.

[0027] In a further embodiment of any of the above, the curve includes another negative slope that extends to the first critical point from at least the 10% span position.

[0028] In a further embodiment of any of the above, the curve includes another positive slope starting at the 0% span position.

[0029] In a further embodiment of any of the above, the positive slope includes a change in slope in a range of 85-95% span position.

[0030] In a further embodiment of any of the above, an ending slope is increasingly negative to the 100% span position.

[0031] In a further embodiment of any of the above, a R_d/X_{TE} in a range 7 to 8 is provided at the change in slope.

[0032] In a further embodiment of any of the above, the positive slope extends from the 0% span position to the inflection point.

[0033] In a further embodiment of any of the above, the positive slope has three inflection points separated by increments in the range of 12-18% span.

[0034] In a further embodiment of any of the above, the negative slope crosses an initial axial trailing edge location arranged at the 0% span position at an axial trailing edge location in the 85-95% span position.

[0035] In a further embodiment of any of the above, the axial trailing edge location in the 85-95% span position has a R_d/X_{TE} in a range 7 to 9.

[0036] In a further embodiment of any of the above, the axial trailing edge location in the 85-95% span position has a R_d/X_{TE} in a range 7 to 8.

[0037] In a further embodiment of any of the above, the airfoil is a fan blade for a gas turbine engine.

[0038] In another exemplary embodiment, a gas turbine engine includes a combustor section arranged between a compressor section and a turbine section, a fan section that has an array of twenty-six or fewer fan blades and has a low fan pressure ratio of less than 1.55 and a geared architecture coupling the fan section to the turbine section or the compressor section. The fan blades include an airfoil having pressure and suction sides. The airfoil extends in a radial direction from a 0% span position at an inner flow path location to a 100% span position at an airfoil tip. The airfoil has a relationship between an axial leading edge location and a span position that is at least a third order polynomial with a generally U-shaped curve having an initial negative slope followed by a positive slope. The positive slope leans aftward and the negative slope leans forward. The curve has a critical point in the range

of 30-50% span position at which the curve changes from the negative slope to the positive slope. The curve is generally linear from 55% span to 75% span and has a positive slope that increases at a rate of about 0.0875 inch (2.22 mm) per 1% span, +/- 0.04 inch (1.01 mm) per 1% span.

[0039] In another exemplary embodiment, a gas turbine engine includes a combustor section arranged between a compressor section and a turbine section, a fan section that has an array of twenty-six or fewer fan blades that have a low fan pressure ratio of less than 1.55 and a geared architecture coupling the fan section to the turbine section or the compressor section. The fan blades include an airfoil that has pressure and suction sides. The airfoil extends in a radial direction from a 0% span position at an inner flow path location to a 100% span position at an airfoil tip. The airfoil has a relationship between an axial leading edge location and a span position that is at least a third order polynomial with a generally U-shaped curve having an initial negative slope followed by a positive slope. The positive slope leans aftward and the negative slope leans forward. The curve has a critical point in the range of 30-50% span position at which the curve changes from the negative slope to the positive slope. The axial leading edge curve is generally linear from 55% span to 75% span and has a positive slope that increases at a rate of about 0.0875 inch (2.22 mm) per 1% span. The airfoil has a relationship between an axial trailing edge location and a span position that is at least a third order polynomial with at least one S-shaped curve that has a negative slope ending at the 100% span position that is preceded by a positive slope, +/- 0.04 inch (1.01 mm) per 1% span.

BRIEF DESCRIPTION OF THE DRAWINGS

[0040] The disclosure can be further understood by reference to the following detailed description when considered in connection with the accompanying drawings wherein:

[0041] Figure 1 schematically illustrates a gas turbine engine embodiment.

[0042] Figure 2A is a perspective view of a portion of a fan section.

[0043] Figure 2B is a schematic cross-sectional view of the fan section.

[0044] Figure 2C is a cross-sectional view a fan blade taken along line 2C-2C in Figure 2B.

[0045] Figure 3A is a schematic view of fan blade span positions.

[0046] Figure 3B is a schematic view of a cross-section of a fan blade section at a particular span position and its axial leading and trailing edge positions.

[0047] Figure 4A illustrates a relationship between an axial leading edge location and a span position for a set of first example airfoils.

[0048] Figure 4B illustrates a relationship between an axial leading edge location and a span position for a set of second example airfoils.

[0049] Figure 4C illustrates a relationship between an axial leading edge location and a span position for a set of third example airfoils.

[0050] Figure 5A illustrates a relationship between an axial trailing edge location and a span position for a set of first example airfoils.

[0051] Figure 5B illustrates a relationship between an axial trailing edge location and a span position for a set of second example airfoils.

[0052] Figure 5C illustrates a relationship between an axial trailing edge location and a span position for a set of third example airfoils.

[0053] The embodiments, examples and alternatives of the preceding paragraphs, the claims, or the following description and drawings, including any of their various aspects or respective individual features, may be taken independently or in any combination. Features described in connection with one embodiment are applicable to all embodiments, unless such features are incompatible.

DETAILED DESCRIPTION

[0054] Figure 1 schematically illustrates a gas turbine engine 20. The gas turbine engine 20 is disclosed herein as a two-spool turbofan that generally incorporates a fan section 22, a compressor section 24, a combustor section 26 and a turbine section 28. Alternative engines might include an augmentor section (not shown) among other systems or features. The fan section 22 drives air along a bypass flow path B in a bypass duct defined within a nacelle 15, while the compressor section 24 drives air along a core flow path C for

compression and communication into the combustor section 26 then expansion through the turbine section 28. Although depicted as a two-spool turbofan gas turbine engine in the disclosed non-limiting embodiment, it should be understood that the concepts described herein are not limited to use with two-spool turbofans as the teachings may be applied to other types of turbine engines including three-spool architectures. That is, the disclosed airfoils may be used for engine configurations such as, for example, direct fan drives, or two- or three-spool engines with a speed change mechanism coupling the fan with a compressor or a turbine sections.

[0055] The exemplary engine 20 generally includes a low speed spool 30 and a high speed spool 32 mounted for rotation about an engine central longitudinal axis X relative to an engine static structure 36 via several bearing systems 38. It should be understood that various bearing systems 38 at various locations may alternatively or additionally be provided, and the location of bearing systems 38 may be varied as appropriate to the application.

[0056] The low speed spool 30 generally includes an inner shaft 40 that interconnects a fan 42, a first (or low) pressure compressor 44 and a first (or low) pressure turbine 46. The inner shaft 40 is connected to the fan 42 through a speed change mechanism, which in exemplary gas turbine engine 20 is illustrated as a geared architecture 48 to drive the fan 42 at a lower speed than the low speed spool 30. The high speed spool 32 includes an outer shaft 50 that interconnects a second (or high) pressure compressor 52 and a second (or high) pressure turbine 54. A combustor 56 is arranged in exemplary gas turbine 20 between the high pressure compressor 52 and the high pressure turbine 54. A mid-turbine frame 57 of the engine static structure 36 is arranged generally between the high pressure turbine 54 and the low pressure turbine 46. The mid-turbine frame 57 further supports bearing systems 38 in the turbine section 28. The inner shaft 40 and the outer shaft 50 are concentric and rotate via bearing systems 38 about the engine central longitudinal axis X which is collinear with their longitudinal axes.

[0057] The core airflow is compressed by the low pressure compressor 44 then the high pressure compressor 52, mixed and burned with fuel in the combustor 56, then expanded over the high pressure turbine 54 and low pressure turbine 46. The mid-turbine frame 57 includes airfoils 59 which are in the core airflow path C. The turbines 46, 54 rotationally drive the respective low speed spool 30 and high speed spool 32 in response to

the expansion. It will be appreciated that each of the positions of the fan section 22, compressor section 24, combustor section 26, turbine section 28, and fan drive gear system 48 may be varied. For example, gear system 48 may be located aft of combustor section 26 or even aft of turbine section 28, and fan section 22 may be positioned forward or aft of the location of gear system 48.

[0058] The engine 20 in one example is a high-bypass geared aircraft engine. In a further example, the engine 20 bypass ratio is greater than about six (6), with an example embodiment being greater than about ten (10), the geared architecture 48 is an epicyclic gear train, such as a planetary gear system or other gear system, with a gear reduction ratio of greater than about 2.3 and the low pressure turbine 46 has a pressure ratio that is greater than about five. In one disclosed embodiment, the engine 20 bypass ratio is greater than about ten (10:1), the fan diameter is significantly larger than that of the low pressure compressor 44, and the low pressure turbine 46 has a pressure ratio that is greater than about five 5:1. Low pressure turbine 46 pressure ratio is pressure measured prior to inlet of low pressure turbine 46 as related to the pressure at the outlet of the low pressure turbine 46 prior to an exhaust nozzle. The geared architecture 48 may be an epicyclic gear train, such as a planetary gear system or other gear system, with a gear reduction ratio of greater than about 2.3:1. It should be understood, however, that the above parameters are only exemplary of one embodiment of a geared architecture engine and that the present invention is applicable to other gas turbine engines including direct drive turbofans.

[0059] The example gas turbine engine includes the fan 42 that comprises in one non-limiting embodiment less than about twenty-six (26) fan blades. In another non-limiting embodiment, the fan section 22 includes less than about twenty (20) fan blades. Moreover, in one disclosed embodiment the low pressure turbine 46 includes no more than about six (6) turbine rotors schematically indicated at 34. In another non-limiting example embodiment the low pressure turbine 46 includes about three (3) turbine rotors. A ratio between the number of fan blades 42 and the number of low pressure turbine rotors is between about 3.3 and about 8.6. The example low pressure turbine 46 provides the driving power to rotate the fan section 22 and therefore the relationship between the number of turbine rotors 34 in the low pressure turbine 46 and the number of blades 42 in the fan section 22 disclose an example gas turbine engine 20 with increased power transfer efficiency.

[0060] A significant amount of thrust is provided by the bypass flow B due to the high bypass ratio. The fan section 22 of the engine 20 is designed for a particular flight condition -- typically cruise at about 0.8 Mach and about 35,000 feet. The flight condition of 0.8 Mach and 35,000 ft, with the engine at its best fuel consumption - also known as "bucket cruise Thrust Specific Fuel Consumption ("TSFC")" - is the industry standard parameter of lbf of thrust the engine produces at that minimum point. "Low fan pressure ratio" is the pressure ratio across the fan blade alone, without a Fan Exit Guide Vane ("FEGV") system. The low fan pressure ratio as disclosed herein according to one non-limiting embodiment is less than about 1.55. In another non-limiting embodiment the low fan pressure ratio is less than about 1.45. In another non-limiting embodiment the low fan pressure ratio is from 1.1 to 1.45. "Low corrected fan tip speed" is the actual fan tip speed in ft/sec divided by an industry standard temperature correction of $[(T_{\text{fan}} / 518.7)]^{0.5}$. The "Low corrected fan tip speed" as disclosed herein according to one non-limiting embodiment is less than about 1200 ft / second.

[0061] Referring to Figure 2A-2C, the fan blade 42 is supported by a fan hub 60 that is rotatable about the axis X. Each fan blade 42 includes an airfoil 64 extending in a radial span direction R from a root 62 to a tip 66. A 0% span position corresponds to a section of the airfoil 64 at the inner flow path (e.g., a platform), and a 100% span position corresponds to a section of the airfoil 64 at the tip 66.

[0062] The root 62 is received in a correspondingly shaped slot in the fan hub 60. The airfoil 64 extends radially outward of the platform, which provides the inner flow path. The platform may be integral with the fan blade or separately secured to the fan hub, for example. A spinner 66 is supported relative to the fan hub 60 to provide an aerodynamic inner flow path into the fan section 22.

[0063] The airfoil 64 has an exterior surface 76 providing a contour that extends from a leading edge 68 aftward in a chord-wise direction H to a trailing edge 70, as shown in Figure 2C. Pressure and suction sides 72, 74 join one another at the leading and trailing edges 68, 70 and are spaced apart from one another in an airfoil thickness direction T. An array of the fan blades 42 are positioned about the axis X in a circumferential or tangential direction Y. Any suitable number of fan blades may be used in a given application.

[0064] The exterior surface 76 of the airfoil 64 generates lift based upon its geometry and directs flow along the core flow path C. The fan blade 42 may be constructed from a composite material, or an aluminum alloy or titanium alloy, or a combination of one or more of these. Abrasion-resistant coatings or other protective coatings may be applied to the fan blade 42.

[0065] One characteristic of fan blade performance relates to the fan blade's axial leading and trailing edge locations (X direction) relative to a particular span position (R direction). Referring to Figure 3A, span positions are schematically illustrated from 0% to 100% in 10% increments. Each section at a given span position is provided by a conical cut that corresponds to the shape of the core flow path, as shown by the large dashed lines. In the case of a fan blade with an integral platform, the 0% span position corresponds to the radially innermost location where the airfoil meets the fillet joining the airfoil to the platform. In the case of a fan blade without an integral platform, the 0% span position corresponds to the radially innermost location where the discrete platform meets the exterior surface of the airfoil. In addition to varying with span, leading and trailing edge axial positions vary between a hot, running condition and a cold, static ("on the bench") condition.

[0066] The axial leading edge location is arranged at the leading edge 68 for a particular section at a given span location relative to a reference point 80 in the X direction, as shown in Figure 3B. The reference point 80 is the axial center of the root, and X_{LE} corresponds to the circumferential distance from the reference point 80 to the axial leading edge location at a given span location.

[0067] The axial trailing edge location is arranged at the trailing edge 70 for a particular section at a given span location relative to the reference point 80 in the X direction. X_{TE} corresponds to the circumferential distance from the reference point 80 to the axial trailing edge location at a given span location.

[0068] A positive X value corresponds to the aftward direction along the engine's axis of rotation. A negative X value corresponds to the forward direction along the engine's axis of rotation.

[0069] The axial leading and trailing edge locations may be expressed as axial leading and trailing edge location ratios R_d/X_{LE} and R_d/X_{TE} , respectively, where R_d is the radial distance from hub's rotational axis X to the tip of the leading edge 68. R_d as disclosed

herein according to one non-limiting embodiment is about 35-37 inches (0.89 – 0.94 meters). In another non-limiting embodiment R_d is about 27-29 inches (0.69 – 0.74 meters). In another non-limiting embodiment R_d is about 39 – 41 inches (0.99 – 1.04 meters). One example prior art airfoil has an R_d of about 57-59 inches (1.45 – 1.50 meters).

[0070] Example relationships between the axial leading edge locations and the span positions, which is the average of the radial position at the leading and trailing edges 68, 70, are shown in Figures 4A-4C for several example fan blades, each represented by a curve. Only one curve in each graph is discussed for simplicity. Each relationship is at least a third order polynomial with a generally U-shaped curve having an initial negative slope followed by a positive slope. A positive slope is where the leading edge leans aftward, and a negative slope is where the leading edge leans forward. The curve has a critical point in the range of 30-50% span position at which the curve changes from the negative slope to the positive slope. Some notable points are indicated by an “x” on the curve. In the examples, the critical point is in the range of 35-40% span position. The axial leading edge curves are generally linear from 55% span to 75% span and have a positive slope that increases at a rate of about 0.0875 inch (2.22 mm) per 1% span, +/- 0.04 inch (1.01 mm) per 1% span. One example prior art axial leading edge curve has a much sharper slope, for example, 0.15 inch (3.81 mm) per 1% span in this same region.

[0071] With continuing reference to Figures 4A-4C, each curve has at least one critical and one inflection point in the example. A first inflection point (92 in Figure 4A; 102 in Figure 4B; 112 in Figure 4C) is where the curve changes from the negative slope to the positive slope. In the examples, the critical point 92 has a R_d/X_{LE} range of -5 to -6, the critical point 102 has a R_d/X_{LE} range of -4 to -6, and the critical point 112 has a R_d/X_{LE} range of -4 to -6.

[0072] A portion of the negative slope (90 in Figure 4A; 100 in Figure 4B; 110 in Figure 4C) is substantially linear for 10-25% span of the airfoil up to about a 25% span position. A portion of the positive slope (94 in Figure 4A; 104 in Figure 4B; 116 in Figure 4C) is substantially linear for 10-15% span of the airfoil and crosses over or bridges about a 65% span position. The positive slope crosses an initial axial leading edge location at the 0% span position at 60-80% span position (at 96 in Figure 4A; at 106 in Figure 4B; at 116 in Figure 4C). Referring to the curve in Figure 4A, the initial axial leading edge location has a

R_d/X_{LE} range of -7 to -9. Referring to the curve in Figure 4B, the initial axial leading edge location has a R_d/X_{LE} range of -6 to -8. Referring to the curve in Figure 4C, the initial axial leading edge location has a R_d/X_{LE} range of -6 to -7. The positive slope changes in a last 20% span of the airfoil (shown at 98 in Figure 4A, at 108 in Figure 4B, and at 118 in Figure 4C).

[0073] Example relationships between the axial trailing edge locations and the span positions are shown in Figures 5A-5C for three fan blades. Each relationship is at least a third order polynomial with at least one S-shaped curve having a negative slope ending at the 100% span position that is preceded by a positive slope. Each curve has a critical point (124 in Figure 5A; 130 in Figure 5B; 140 in Figure 5C) in the range of 55-85% span position at which the curve changes from the positive slope to the negative slope. In the examples, the critical point is in the range of 60-80% span position. In the example curves shown, there are at least three inflection points.

[0074] Referring to Figure 5A, the critical point 124 has a R_d/X_{TE} in the range of 7 to 8. Referring to Figure 5B, the critical point 130 has a R_d/X_{TE} in the range of 7 to 8. Referring to Figure 5C, the critical point 140 has a R_d/X_{TE} in the range of 5 to 7.

[0075] The inflection points 124 and 130 are a second critical point, and the curves include a first critical point (122 in Figure 5A; 128 in Figure 5B) in the range of 25-45% span position. The positive slope extends from the first critical point 122, 128 respectively, to the second critical point 124, 130.. Referring to Figure 5A, the first critical point 122 has a R_d/X_{TE} in a range of 8 to 10. Referring to Figure 5B, the first critical point 128 has a R_d/X_{TE} in a range of 8 to 9.

[0076] Referring to Figure 5A, the negative slope crosses an initial axial trailing edge location arranged at the 0% span position at an axial trailing edge location 127 in the 85-95% span position. The axial trailing edge location 127 in the 85-95% span position has a R_d/X_{TE} in a range of 7 to 9.

[0077] Referring to Figures 5A and 5B, the curve includes another negative slope extending to the first critical point from at least the 10% span position. The curve includes another positive slope starting at the 0% span position to a critical point 120, as shown in Figure 5A. The positive slope includes a change in slope in a range of 85-95% span position, as shown by the inflection points 126, 132 in Figures 5A and 5B, respectively. A R_d/X_{TE} in a

range of 7 to 8 is provided at the change in slope. In one example, an ending slope is increasingly negative to the 100% span position, as shown in Figure 5B.

[0078] Referring to Figure 5C, the positive slope extends from the 0% span position to the first inflection point 134. The positive slope has three inflection points 134, 136, 138 separated by increments in the range of 12-18% span. The negative slope crosses an initial axial trailing edge location arranged at the 0% span position at an axial trailing edge location 142 in the 85-95% span position. The axial trailing edge location 142 in the 85-95% span position has a R_d/X_{TE} in a range of 7 to 8.

[0079] The leading and trailing edge axial positions in a hot, running condition along the span of the airfoils 64 relate to the contour of the airfoil and provide necessary fan operation in cruise at the lower, preferential speeds enabled by the geared architecture 48 in order to enhance aerodynamic functionality and thermal efficiency. As used herein, the hot, running condition is the condition during cruise of the gas turbine engine 20. For example, the leading and trailing edge axial positions in the hot, running condition can be determined in a known manner using numerical analysis, such as finite element analysis.

[0080] It should also be understood that although a particular component arrangement is disclosed in the illustrated embodiment, other arrangements will benefit herefrom. Although particular step sequences are shown, described, and claimed, it should be understood that steps may be performed in any order, separated or combined unless otherwise indicated and will still benefit from the present invention.

[0081] Although the different examples have specific components shown in the illustrations, embodiments of this invention are not limited to those particular combinations. It is possible to use some of the components or features from one of the examples in combination with features or components from another one of the examples.

[0082] Although an example embodiment has been disclosed, a worker of ordinary skill in this art would recognize that certain modifications would come within the scope of the claims. For that reason, the following claims should be studied to determine their true scope and content.

CLAIMS

What is claimed is:

1. An airfoil for a turbine engine comprising:
pressure and suction sides extending in a radial direction from a 0% span position at an inner flow path location to a 100% span position at an airfoil tip, wherein the airfoil has a relationship between an axial leading edge location and a span position that is at least a third order polynomial with a generally U-shaped curve having an initial negative slope followed by a positive slope, the positive slope leans aftward and the negative slope leans forward, the curve having a critical point in the range of 30-50% span position at which the curve changes from the negative slope to the positive slope, wherein the curve is generally linear from 55% span to 75% span and has a positive slope that increases at a rate of about 0.0875 inch (2.22 mm) per 1% span, +/- 0.04 inch (1.01 mm) per 1% span.
2. The airfoil according to claim 1, wherein the curve has at least one inflection point.
3. The airfoil according to claim 2, wherein the airfoil extends from a root, and a zero axial leading edge location corresponds to axial center of the root.
4. The airfoil according to claim 1, wherein the critical point is in the range of 35-40% span position.
5. The airfoil according to claim 4, wherein a portion of the negative slope is substantially linear for 10-25% span of the airfoil up to about a 25% span position.
6. The airfoil according to claim 4, wherein a portion of the positive slope is substantially linear for 10-15% span of the airfoil and crosses over about a 65% span position.
7. The airfoil according to claim 4, wherein the positive slope crosses an initial axial leading edge location at the 0% span position at 60-80% span position.

8. The airfoil according to claim 7, wherein the initial axial leading edge location has a R_d/X_{LE} in a range -7 to -9.

9. The airfoil according to claim 7, wherein the initial axial leading edge location has a R_d/X_{LE} in a range -6 to -8.

10. The airfoil according to claim 7, wherein the initial axial leading edge location has a R_d/X_{LE} in a range -6 to -7.

11. The airfoil according to claim 7, wherein the positive slope changes in a last 20% span of the airfoil.

12. The airfoil according to claim 1, wherein the airfoil is a fan blade for a gas turbine engine.

13. The airfoil according to claim 1, wherein the airfoil has a relationship between an axial trailing edge location and a span position that is at least a third order polynomial with at least one S-shaped curve having a negative slope ending at the 100% span position that is preceded by a positive slope, the positive slope leans aftward and the negative slope leans forward, the curve having a critical point in the range of 55-85% span position at which the curve changes from the positive slope to the negative slope.

14. The airfoil according to claim 13, wherein the curve has at least three inflection points.

15. The airfoil according to claim 14, wherein the airfoil extends from a root, and a zero axial trailing edge location corresponds to axial center of the root.

16. The airfoil according to claim 13, wherein the critical point is in the range of 60-80% span position.

17. The airfoil according to claim 16, wherein the critical point has a R_d/X_{TE} in a range 7 to 8.

18. The airfoil according to claim 16, wherein the critical point has a R_d/X_{TE} in a range 7 to 8.

19. The airfoil according to claim 16, wherein the critical point has a R_d/X_{TE} in a range 5 to 7.

20. The airfoil according to claim 16, wherein the critical point is a second critical point, and the curve includes a first critical point is in the range of 25-45% span position, the positive slope extending from the first critical point to the second critical point.

21. The airfoil according to claim 20, wherein the first critical point has a R_d/X_{TE} in a range 8 to 10.

22. The airfoil according to claim 20, wherein the first critical point has a R_d/X_{TE} in a range 8 to 9.

23. The airfoil according to claim 20, wherein the curve includes another negative slope extending to the first critical point from at least the 10% span position.

24. The airfoil according to claim 23, wherein the curve includes another positive slope starting at the 0% span position.

25. The airfoil according to claim 20, wherein the positive slope includes a change in slope in a range of 85-95% span position.

26. The airfoil according to claim 25, wherein an ending slope is increasingly negative to the 100% span position.

27. The airfoil according to claim 26, wherein a R_d/X_{TE} in a range 7 to 8 is provided at the change in slope.

28. The airfoil according to claim 16, wherein the positive slope extends from the 0% span position to the inflection point.

29. The airfoil according to claim 28, wherein the positive slope has three inflection points separated by increments in the range of 12-18% span.

30. The airfoil according to claim 16, wherein the negative slope crosses an initial axial trailing edge location arranged at the 0% span position at an axial trailing edge location in the 85-95% span position.

31. The airfoil according to claim 30, wherein the axial trailing edge location in the 85-95% span position has a R_d/X_{TE} in a range 7 to 9.

32. The airfoil according to claim 30, wherein the axial trailing edge location in the 85-95% span position has a R_d/X_{TE} in a range 7 to 8.

33. The airfoil according to claim 13, wherein the airfoil is a fan blade for a gas turbine engine.

34. A gas turbine engine comprising:
a combustor section arranged between a compressor section and a turbine section;
a fan section having an array of twenty-six or fewer fan blades, wherein the fan section has a low fan pressure ratio of less than 1.55;
a geared architecture coupling the fan section to the turbine section or the compressor section; and

wherein the fan blades include an airfoil having pressure and suction sides, the airfoil extends in a radial direction from a 0% span position at an inner flow path location to a 100% span position at an airfoil tip, wherein the airfoil has a relationship between an axial leading edge location and a span position that is at least a third order polynomial with a generally U-shaped curve having an initial negative slope followed by a positive slope, the positive slope leans aftward and the negative slope leans forward, the curve having a critical point in the range of 30-50% span position at which the curve changes from the negative slope to the positive slope, and the curve is generally linear from 55% span to 75% span and has a positive slope that increases at a rate of about 0.0875 inch (2.22 mm) per 1% span, +/- 0.04 inch (1.01 mm) per 1% span.

35. A gas turbine engine comprising:
a combustor section arranged between a compressor section and a turbine section;
a fan section having an array of twenty-six or fewer fan blades, wherein the fan section has a low fan pressure ratio of less than 1.55;
a geared architecture coupling the fan section to the turbine section or the compressor section; and

wherein the fan blades include an airfoil having pressure and suction sides, the airfoil extends in a radial direction from a 0% span position at an inner flow path location to a 100% span position at an airfoil tip, wherein the airfoil has a relationship between an axial leading edge location and a span position that is at least a third order polynomial with a generally U-shaped curve having an initial negative slope followed by a positive slope, the positive slope leans aftward and the negative slope leans forward, the curve having a critical point in the range of 30-50% span position at which the curve changes from the negative slope to the positive slope, and the axial leading edge curve is generally linear from 55% span to 75% span and has a positive slope that increases at a rate of about 0.0875 inch (2.22 mm) per 1% span, wherein the airfoil has a relationship between an axial trailing edge location and a span position that is at least a third order polynomial with at least one S-shaped curve having a negative slope ending at the 100% span position that is preceded by a positive slope, +/- 0.04 inch (1.01 mm) per 1% span.

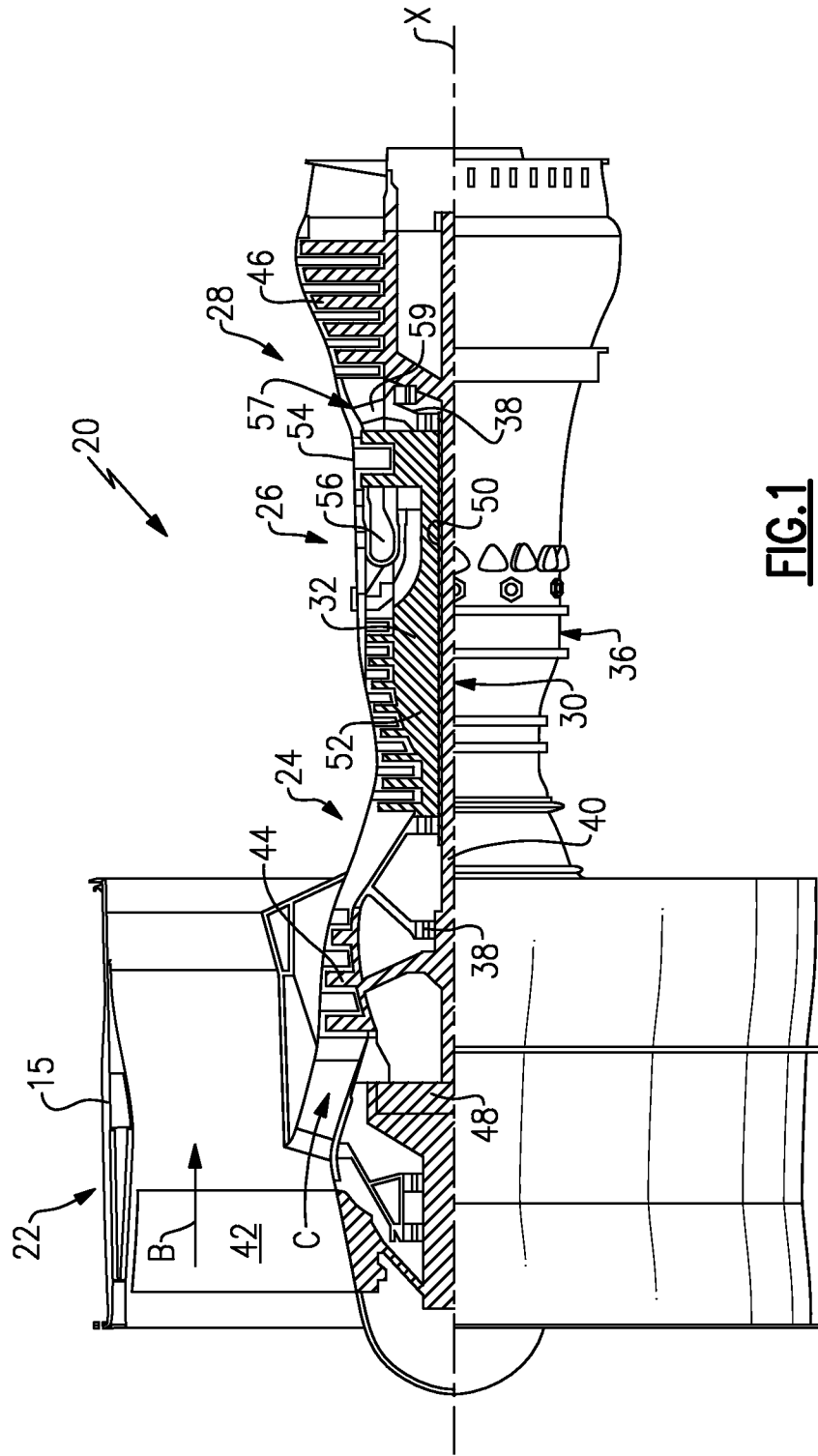

FIG.1

2/5

FIG.2A

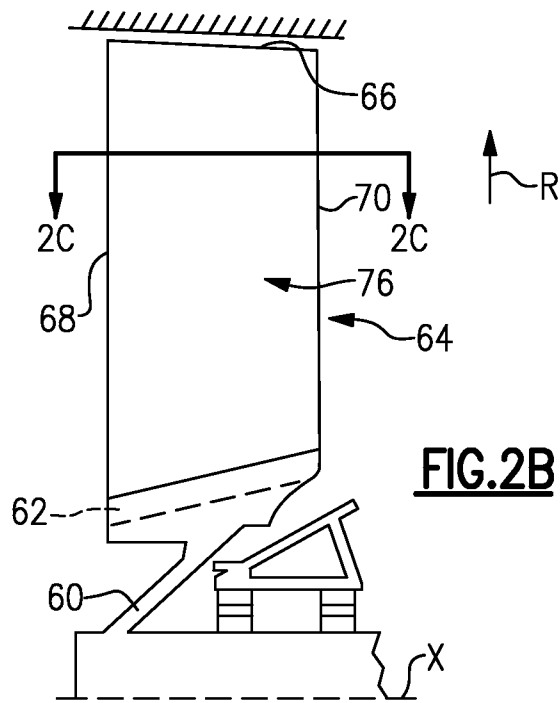
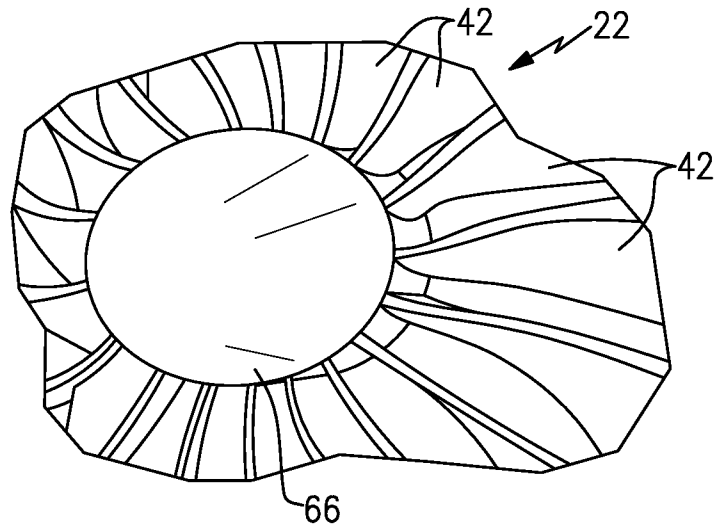

FIG.2B

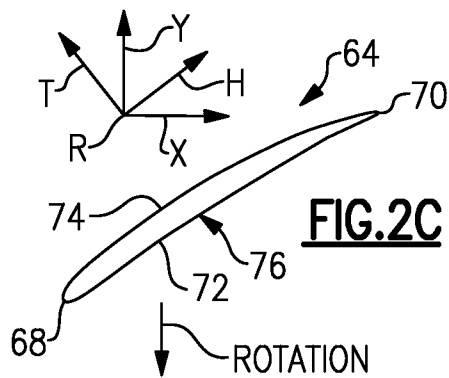

FIG.2C

3/5

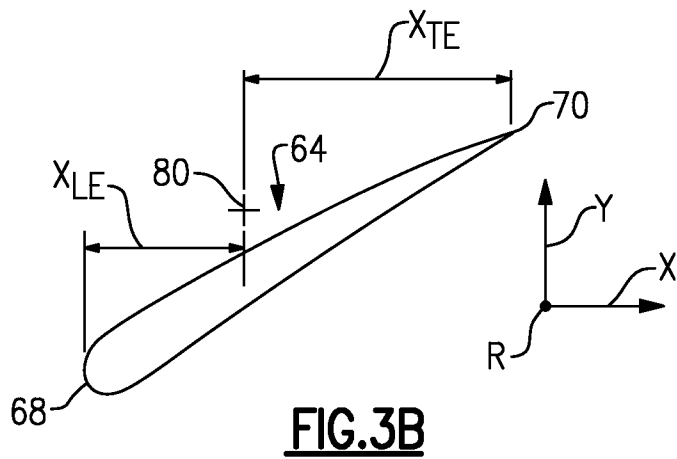
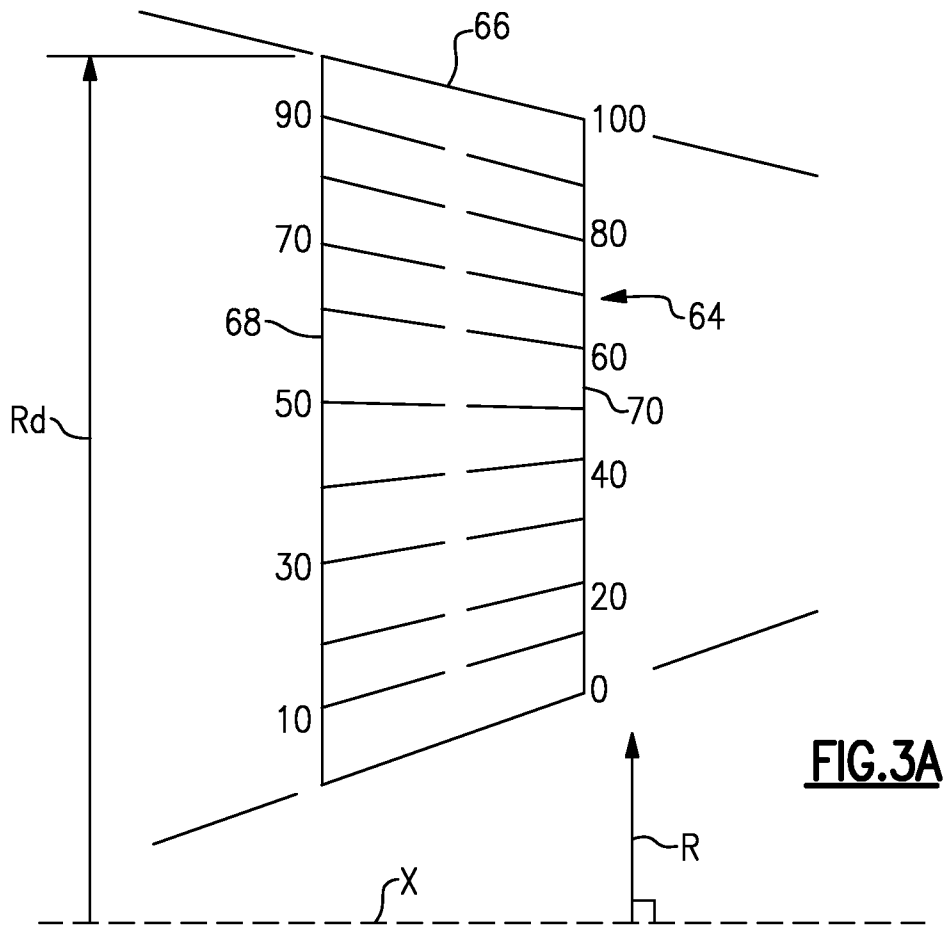

FIG.4A

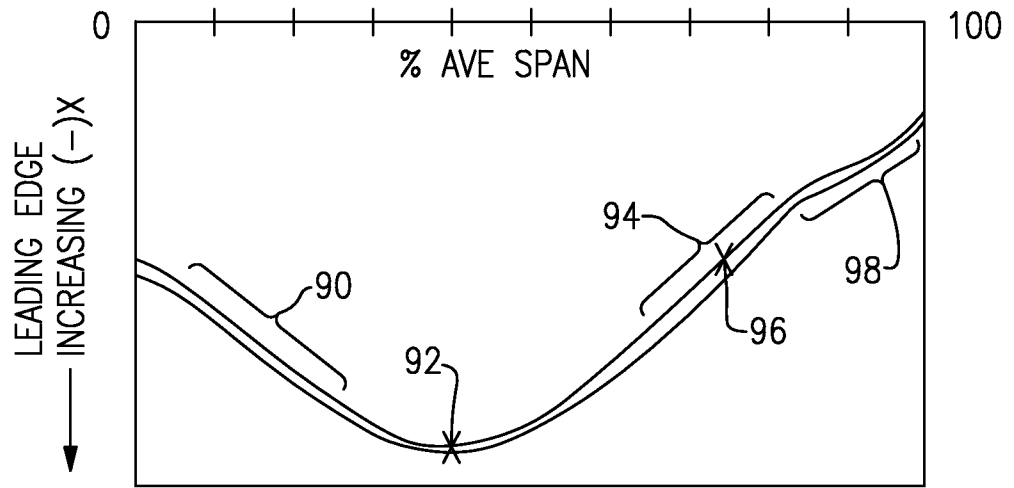

FIG.4B

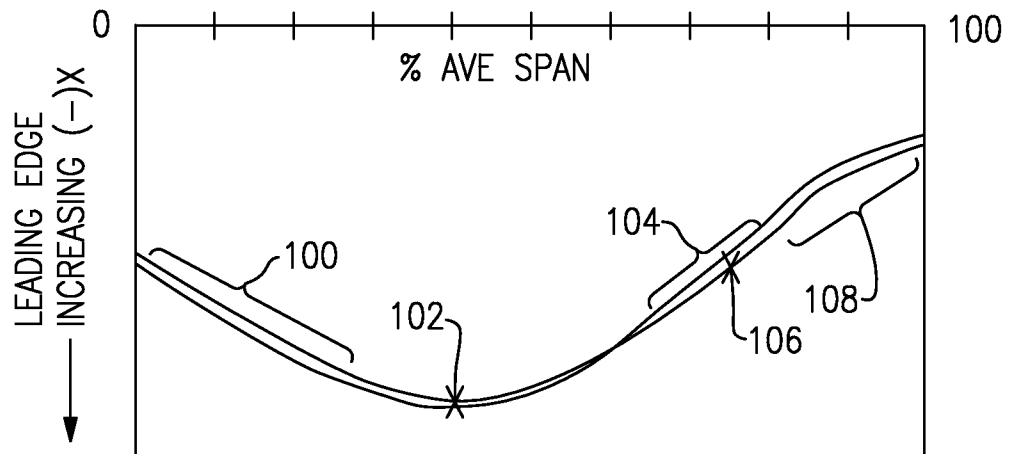
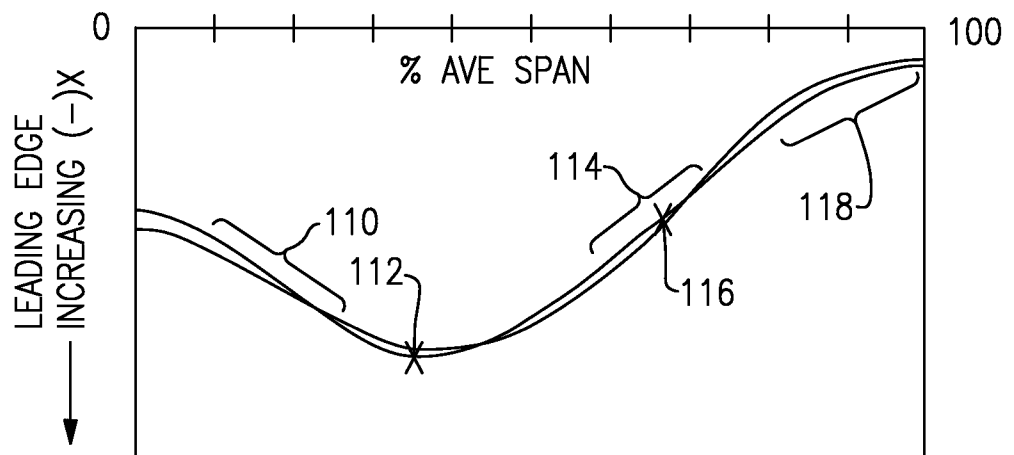

FIG.4C



5/5

FIG.5A

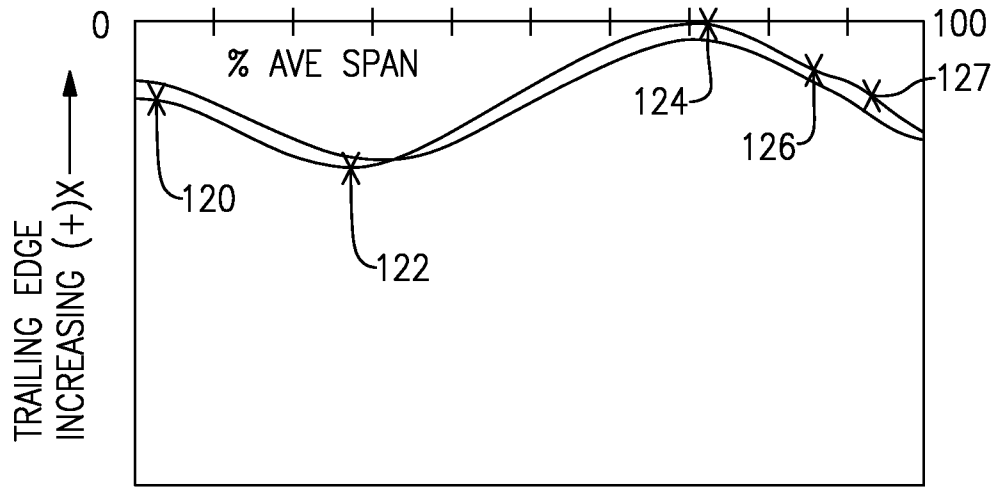

FIG.5B

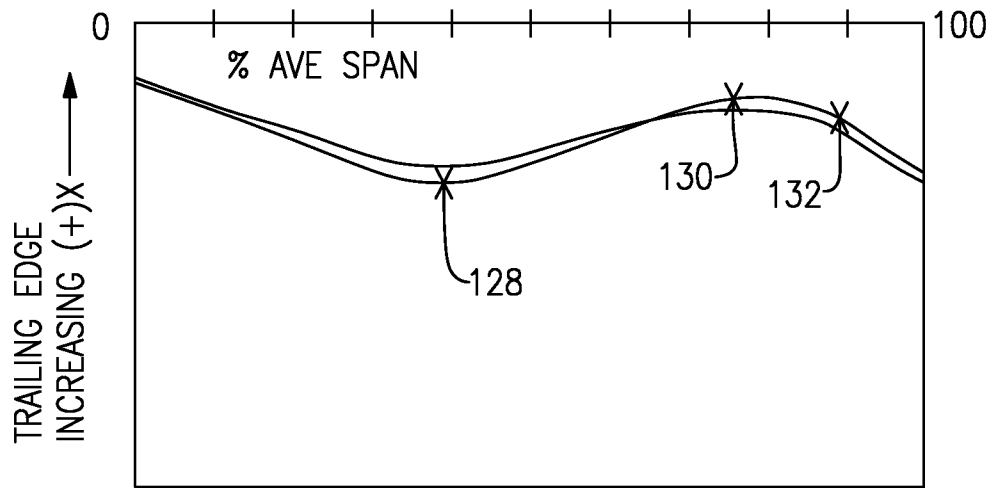
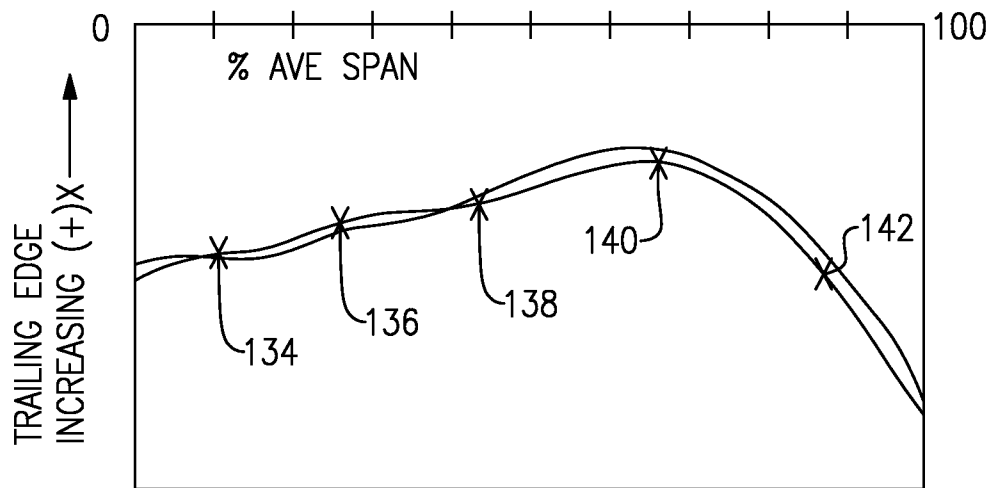

FIG.5C



A. CLASSIFICATION OF SUBJECT MATTER**F01D 5/14(2006.01)i**

According to International Patent Classification (IPC) or to both national classification and IPC

B. FIELDS SEARCHEDMinimum documentation searched (classification system followed by classification symbols)
F01D 5/14; F01D 5/02; F01D 1/00; F02C 1/00; F04D 29/38; F04D 29/54; F03B 11/02Documentation searched other than minimum documentation to the extent that such documents are included in the fields searched
Korean utility models and applications for utility models
Japanese utility models and applications for utility modelsElectronic data base consulted during the international search (name of data base and, where practicable, search terms used)
eKOMPASS(KIPO internal) & Keywords: turbine engine, compressor, fan, blade, geared architecture, airfoil, span, negative slope, positive slope, curve**C. DOCUMENTS CONSIDERED TO BE RELEVANT**

Category*	Citation of document, with indication, where appropriate, of the relevant passages	Relevant to claim No.
X Y A	US 2008-0148564 A1 (BURTON et al.) 26 June 2008 See abstract; paragraphs [0026]-[0028], [0031]-[0036]; and figures 1-5.	1-12 34 13-33,35
Y	US 2013-0008170 A1 (GALLAGHER et al.) 10 January 2013 See abstract; paragraphs [0017]-[0019], [0023], [0031], [0033]; and figures 1-5.	34
A	US 2008-0226454 A1 (DECKER et al.) 18 September 2008 See abstract; paragraphs [0030]-[0031], [0035], [0046]-[0047]; and figures 1-2, 5, 8-9B.	1-35
A	US 6079948 A (SASAKI et al.) 27 June 2000 See abstract; column 7, lines 1-31, column 8, lines 3-31, column 10, lines 1-17; and figures 1-3, 7-9, 12.	1-35
A	US 2006-0210395 A1 (SCHUSTER et al.) 21 September 2006 See abstract; paragraphs [0024]-[0026], [0028]-[0029]; and figures 1-4.	1-35

 Further documents are listed in the continuation of Box C. See patent family annex.

* Special categories of cited documents:

"A" document defining the general state of the art which is not considered to be of particular relevance

"E" earlier application or patent but published on or after the international filing date

"L" document which may throw doubts on priority claim(s) or which is cited to establish the publication date of another citation or other special reason (as specified)

"O" document referring to an oral disclosure, use, exhibition or other means

"P" document published prior to the international filing date but later than the priority date claimed

"T" later document published after the international filing date or priority date and not in conflict with the application but cited to understand the principle or theory underlying the invention

"X" document of particular relevance; the claimed invention cannot be considered novel or cannot be considered to involve an inventive step when the document is taken alone

"Y" document of particular relevance; the claimed invention cannot be considered to involve an inventive step when the document is combined with one or more other such documents, such combination being obvious to a person skilled in the art

"&" document member of the same patent family

Date of the actual completion of the international search

28 May 2015 (28.05.2015)

Date of mailing of the international search report

29 May 2015 (29.05.2015)

Name and mailing address of the ISA/KR

International Application Division
Korean Intellectual Property Office
189 Cheongsu-ro, Seo-gu, Daejeon Metropolitan City, 302-701,
Republic of Korea

Facsimile No. +82-42-472-7140

Authorized officer

LEE, Dal Kyong

Telephone No. +82-42-481-5606



INTERNATIONAL SEARCH REPORT

Information on patent family members

International application No.

PCT/US2014/052293

Patent document cited in search report	Publication date	Patent family member(s)	Publication date
US 2008-0148564 A1	26/06/2008	CA 2613601 A1	22/06/2008
		EP 1939399 A2	02/07/2008
		EP 1939399 A3	05/05/2010
		EP 1939399 B1	28/03/2012
		JP 05301148 B2	25/09/2013
		JP 2008-157247 A	10/07/2008
		US 7758306 B2	20/07/2010
		US 2013-0008170 A1	10/01/2013
US 2008-0226454 A1	18/09/2008	US 8337154 B2	25/12/2012
		WO 2008-109036 A1	12/09/2008
US 6079948 A	27/06/2000	AU 1997-39302 B2	28/01/1999
		AU 1999-23925 A1	03/06/1999
		AU 1999-23925 B2	22/03/2001
		CN 1100194 C	29/01/2003
		CN 1179503 A	22/04/1998
		EP 0833060 A2	01/04/1998
		EP 0833060 A3	02/12/1998
		EP 0833060 B1	10/04/2002
		JP 10-103002 A	21/04/1998
		KR 10-0248129 B1	01/04/2000
		KR 10-1998-0024999 A	06/07/1998
US 2006-0210395 A1	21/09/2006	CA 2582279 A1	04/01/2007
		GB 0705914 D0	09/05/2007
		GB 2434183 A	18/07/2007
		GB 2434183 B	29/07/2009
		US 7547186 B2	16/06/2009
		WO 2007-001389 A2	04/01/2007
		WO 2007-001389 A3	19/04/2007