



US009136396B2

(12) **United States Patent**
Ko et al.

(10) **Patent No.:** **US 9,136,396 B2**
(45) **Date of Patent:** **Sep. 15, 2015**

(54) **SEMICONDUCTOR DEVICE AND METHOD OF MANUFACTURING THE SAME**

(58) **Field of Classification Search**
CPC . H01L 21/486; H01L 29/808; H01L 29/4175;
H01L 29/7786; H01L 29/66462; H01L 29/66;
H01L 29/66924
See application file for complete search history.

(71) Applicant: **Electronics and Telecommunications Research Institute**, Daejeon (KR)

(72) Inventors: **Sang Choon Ko**, Daejeon (KR); **Jae Kyoung Mun**, Daejeon (KR); **Byoung-Gue Min**, Daejeon (KR); **Young Rak Park**, Daejeon (KR); **Hokyun Ahn**, Daejeon (KR); **Jeong-Jin Kim**, Jeollabuk-do (KR); **Eun Soo Nam**, Daejeon (KR)

(56) **References Cited**

U.S. PATENT DOCUMENTS

6,531,328 B1 * 3/2003 Chen 438/26
7,233,028 B2 6/2007 Weeks

(Continued)

FOREIGN PATENT DOCUMENTS

JP 2008-258281 A 10/2008
JP 2012-038885 A 2/2012

OTHER PUBLICATIONS

Azadeh Ansari et al., "Gallium Nitride-on-Silicon Micromechanical Overtone Resonators and Filters", Electron Devices Meeting (IEDM), 2011 IEEE International, Dec. 5-7, 2011, pp. 20.3.1-20.3.4.

(Continued)

Primary Examiner — Minh-Loan Tran
Assistant Examiner — Fazli Erdem

(74) *Attorney, Agent, or Firm* — Rabin & Berdo, P.C.

(73) Assignee: **ELECTRONICS AND TELECOMMUNICATIONS RESEARCH INSTITUTE**, Daejeon (KR)

(*) Notice: Subject to any disclaimer, the term of this patent is extended or adjusted under 35 U.S.C. 154(b) by 0 days.

(21) Appl. No.: **13/905,213**

(22) Filed: **May 30, 2013**

(65) **Prior Publication Data**

US 2014/0159049 A1 Jun. 12, 2014

(30) **Foreign Application Priority Data**

Dec. 12, 2012 (KR) 10-2012-0144273

(51) **Int. Cl.**

H01L 29/66 (2006.01)
H01L 29/808 (2006.01)

(Continued)

(52) **U.S. Cl.**

CPC **H01L 29/808** (2013.01); **H01L 29/4175** (2013.01); **H01L 29/66462** (2013.01); **H01L 29/7786** (2013.01); **H01L 29/2003** (2013.01);

(Continued)

(57) **ABSTRACT**

A method of manufacturing a semiconductor device includes forming devices including source, drain and gate electrodes on a front surface of a substrate including a bulk silicon, a buried oxide layer, an active silicon, a gallium nitride layer, and an aluminum-gallium nitride layer sequentially stacked, etching a back surface of the substrate to form a via-hole penetrating the substrate and exposing a bottom surface of the source electrode, conformally forming a ground interconnection on the back surface of the substrate having the via-hole, forming a protecting layer on the front surface of the substrate, and cutting the substrate to separate the devices from each other.

14 Claims, 11 Drawing Sheets

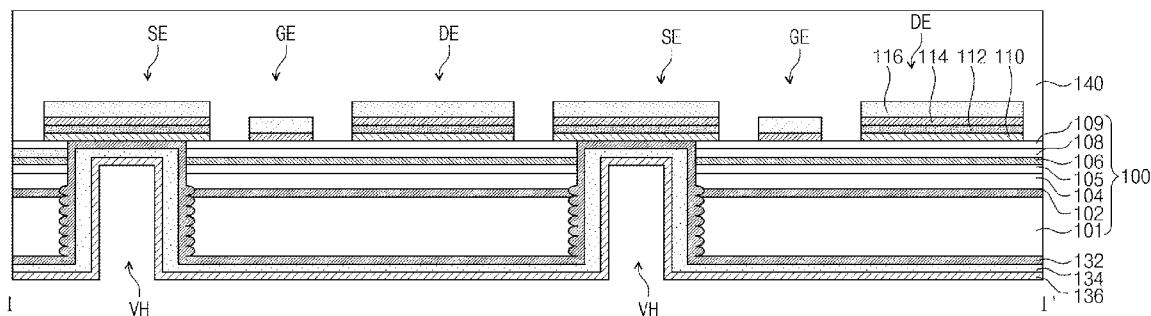

- (51) **Int. Cl.**
H01L 29/417 (2006.01)
H01L 29/778 (2006.01)
H01L 29/43 (2006.01)
H01L 29/45 (2006.01)
H01L 29/20 (2006.01)
- (52) **U.S. Cl.**
 CPC *H01L 29/41758* (2013.01); *H01L 29/432*
 (2013.01); *H01L 29/454* (2013.01)

(56) **References Cited**

U.S. PATENT DOCUMENTS

8,350,288	B2	1/2013	Therrien et al.	
2002/0117681	A1 *	8/2002	Weeks et al.	257/106
2004/0130002	A1 *	7/2004	Weeks et al.	257/622
2007/0284602	A1 *	12/2007	Chitnis et al.	257/98
2007/0295985	A1 *	12/2007	Weeks et al.	257/103
2008/0073752	A1 *	3/2008	Asai et al.	257/615
2008/0149964	A1 *	6/2008	Sugimoto et al.	257/192
2008/0206989	A1 *	8/2008	Kruger et al.	438/667

2008/0286963	A1 *	11/2008	Krueger et al.	438/637
2009/0001478	A1 *	1/2009	Okamoto	257/382
2009/0194773	A1 *	8/2009	Hanson et al.	257/77
2010/0059791	A1	3/2010	Takagi	
2010/0295100	A1 *	11/2010	Huang et al.	257/256
2011/0241074	A1 *	10/2011	Okamoto	257/194
2012/0007101	A1 *	1/2012	Yang et al.	257/76
2012/0021582	A1 *	1/2012	Nishi	438/299
2012/0153476	A1 *	6/2012	Shen	257/750
2012/0175777	A1 *	7/2012	Hill et al.	257/753
2012/0228650	A1 *	9/2012	Chern et al.	257/88
2012/0320550	A1 *	12/2012	Bar et al.	361/760
2012/0329213	A1 *	12/2012	Vinciguerra et al.	438/113
2013/0026631	A1 *	1/2013	Min	257/750
2013/0277845	A1 *	10/2013	Chen et al.	257/762

OTHER PUBLICATIONS

Masahiro Hikita et al., "AlGaIn/GaN Power HFET on Silicon Substrate With Source-Via Grounding (SVG) Structure", IEEE Transactions on Electron Devices, Sep. 2005, pp. 1963-1968, vol. 52, No. 9.

* cited by examiner

Fig. 1A

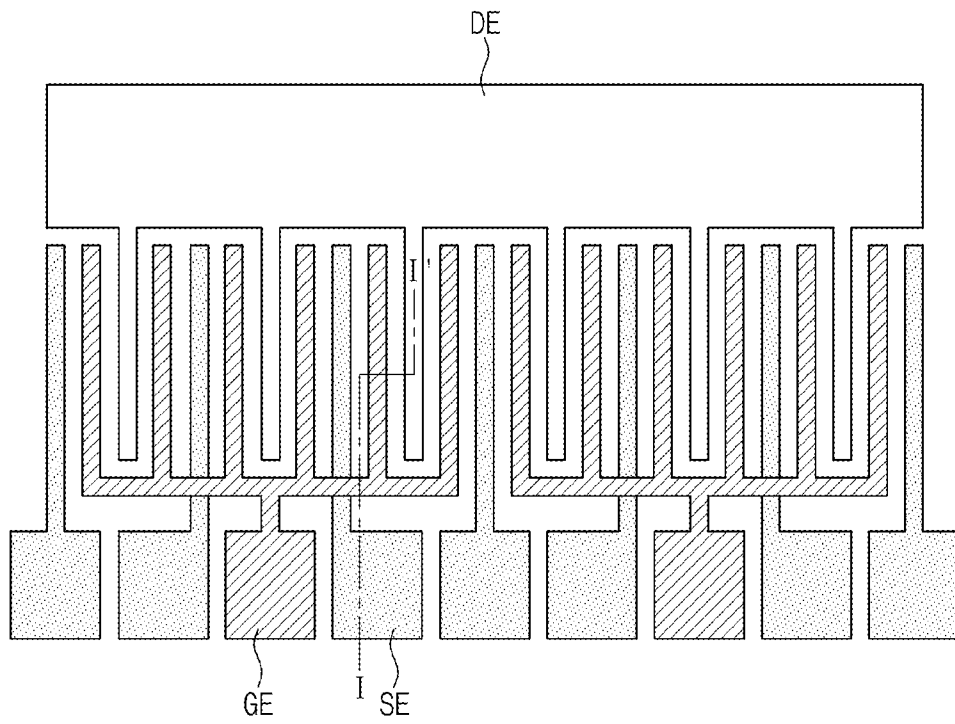

Fig. 1B

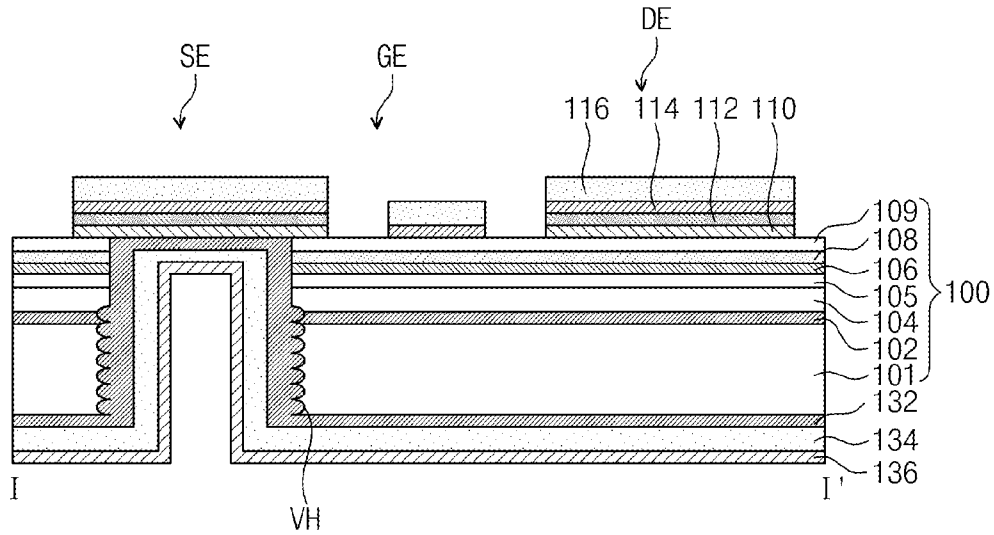

Fig. 1C

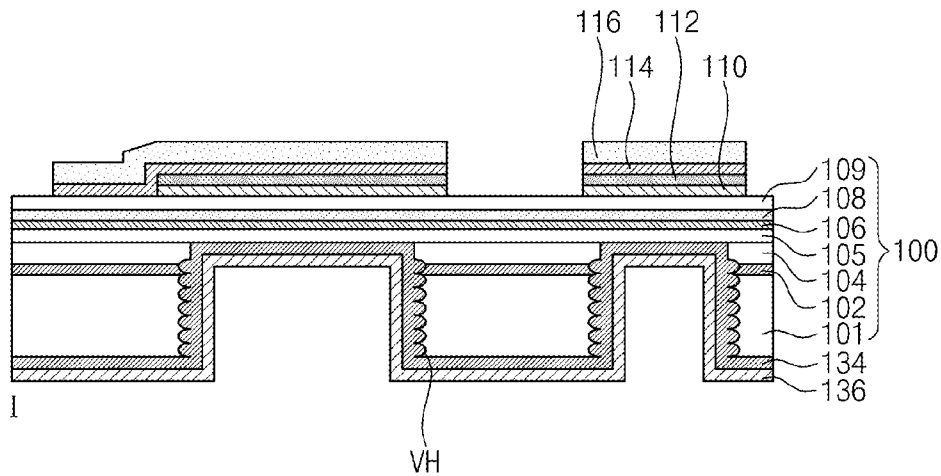

Fig. 2A

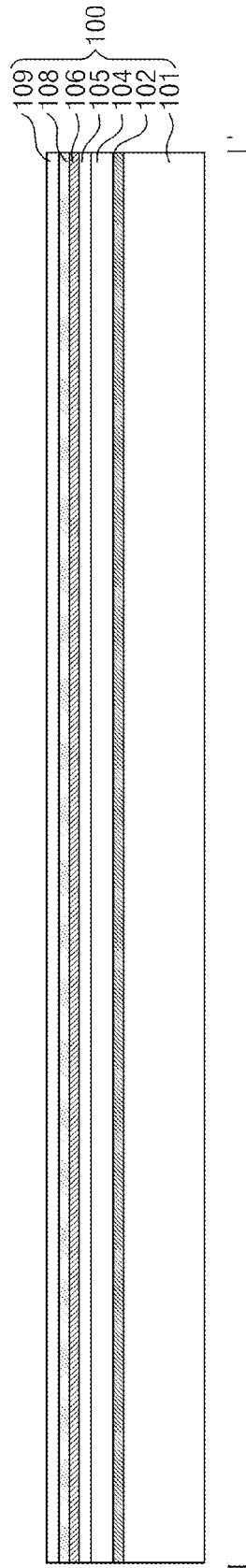

Fig. 2B

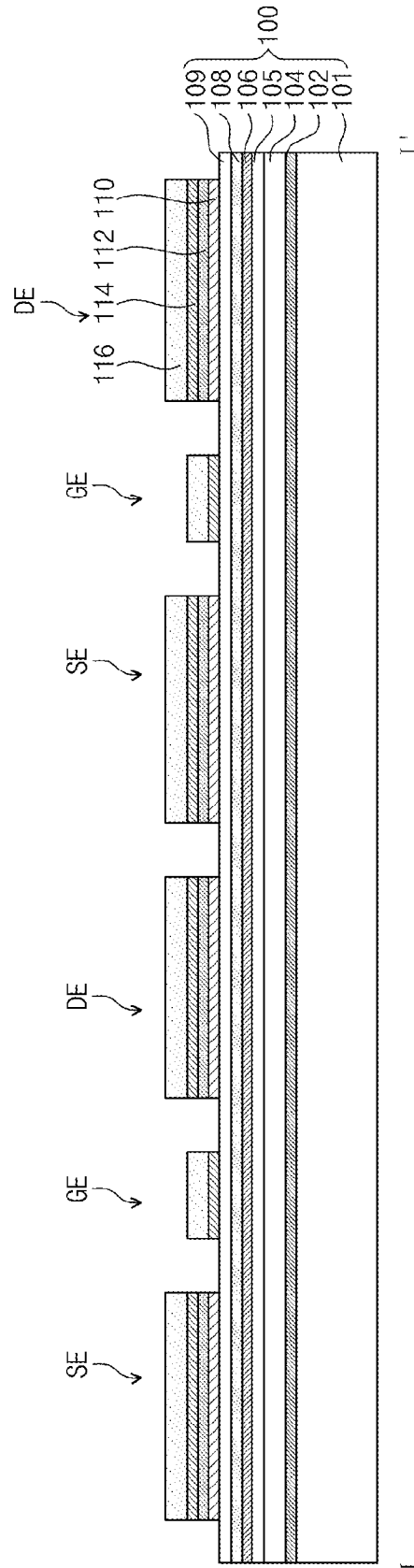

Fig. 2C

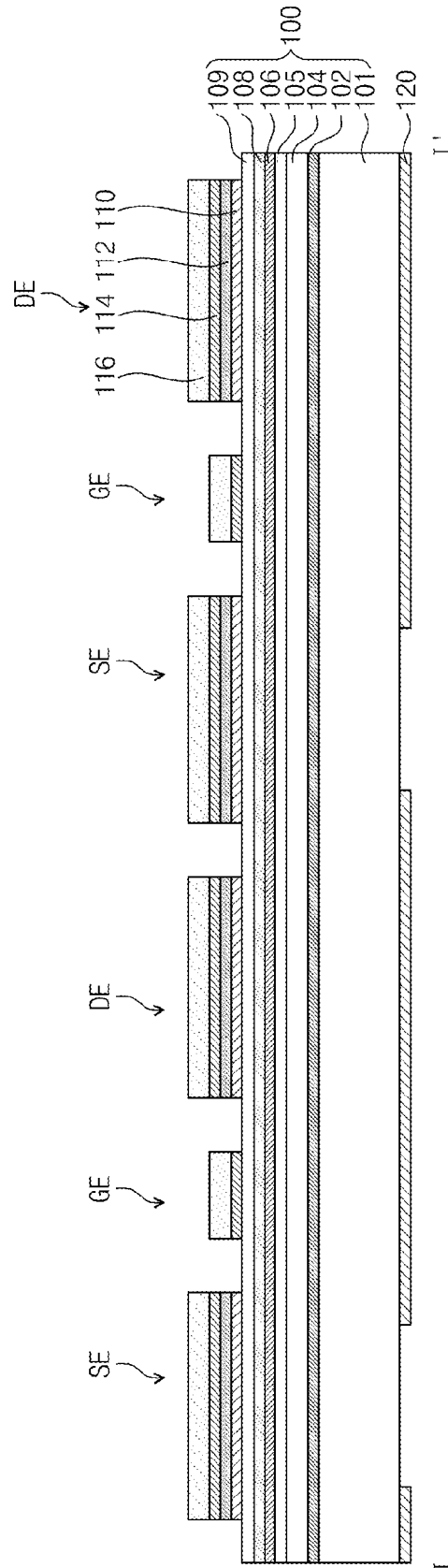

Fig. 2D

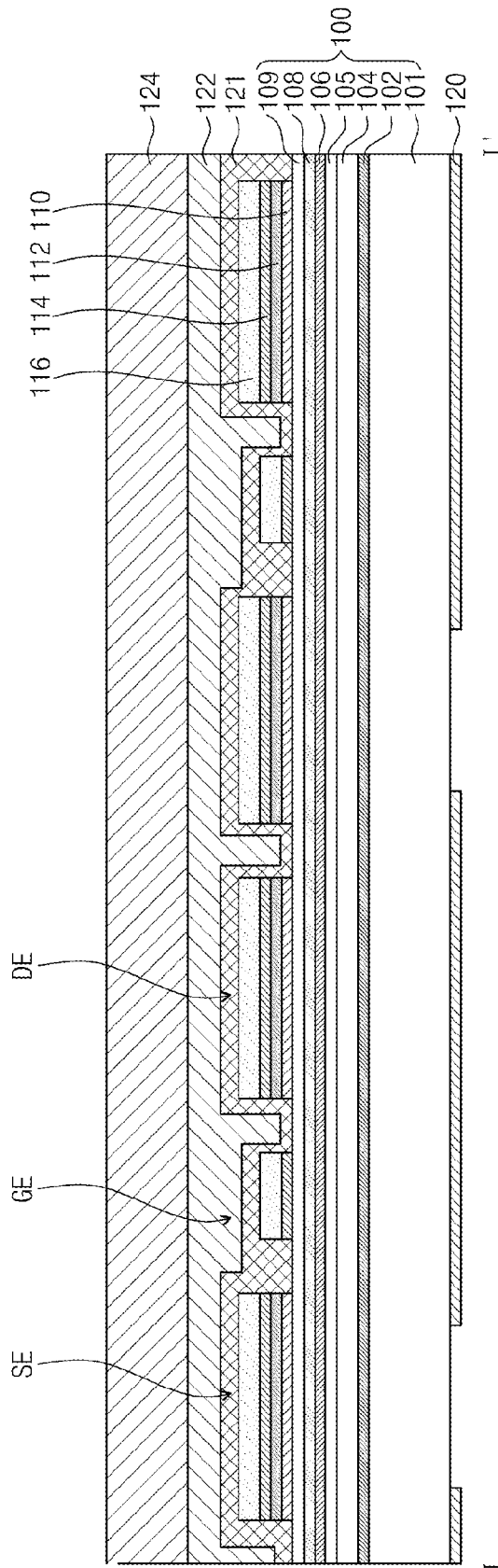

Fig. 2E

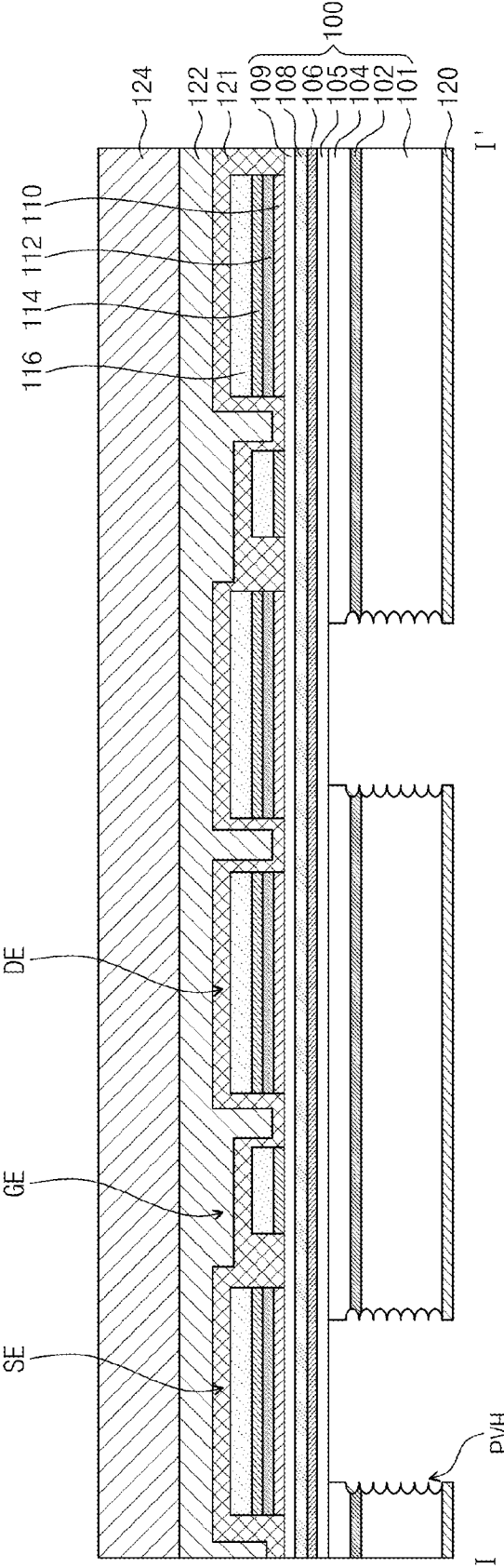

Fig. 2F

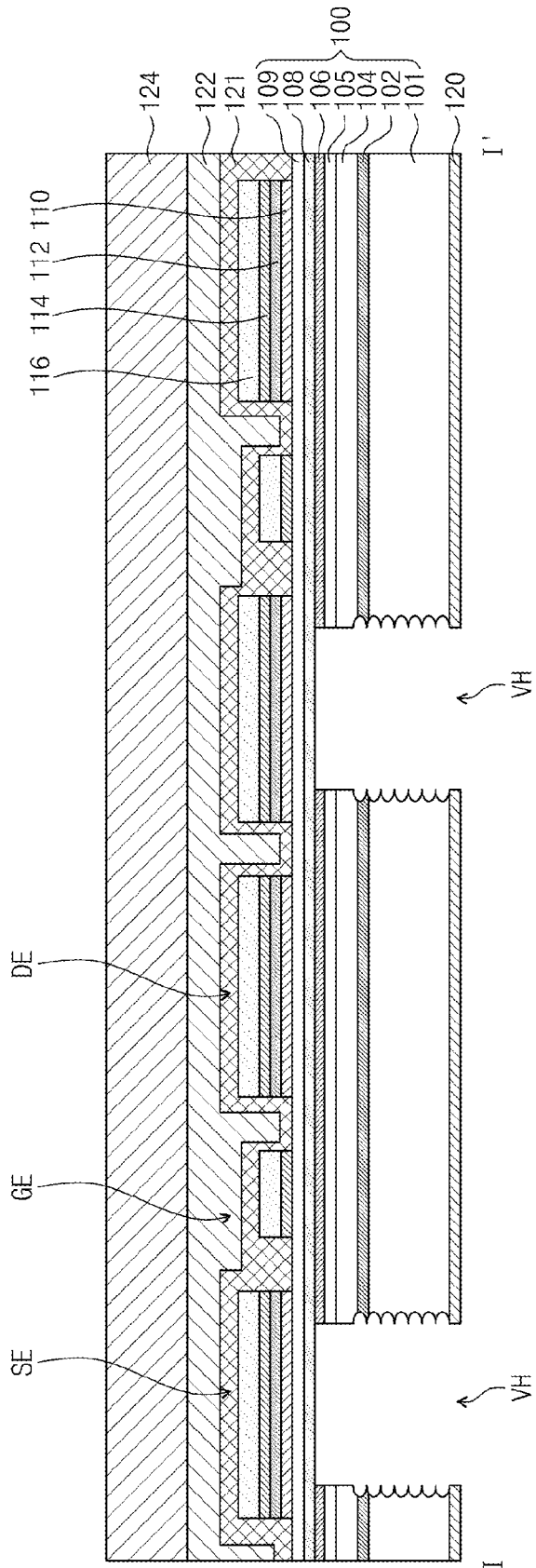

Fig. 2G

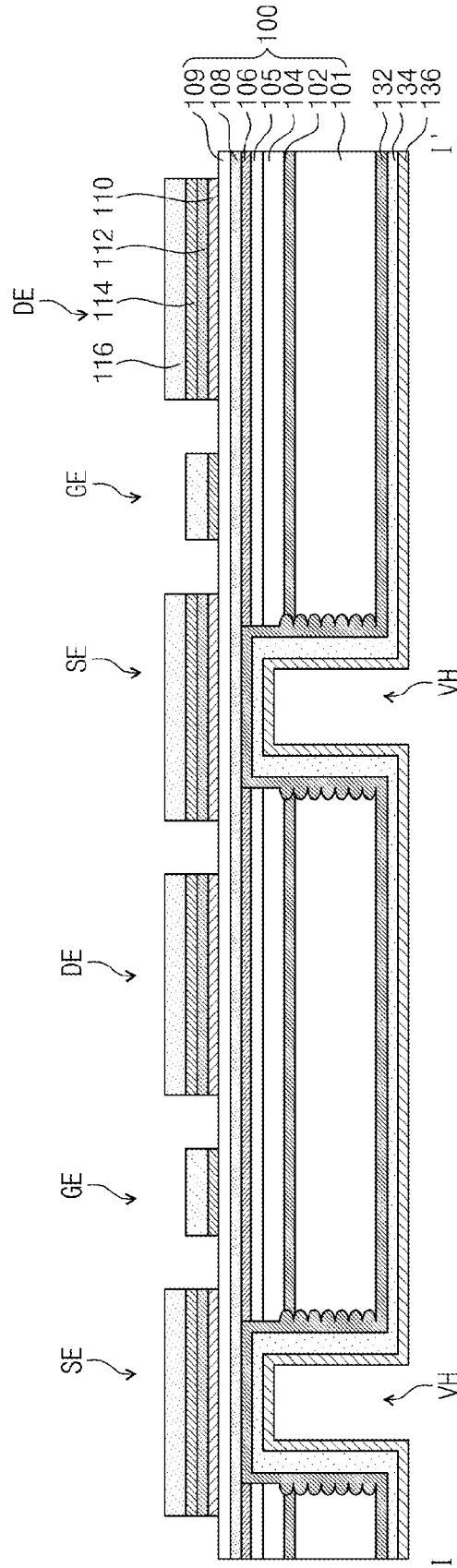

Fig. 2H

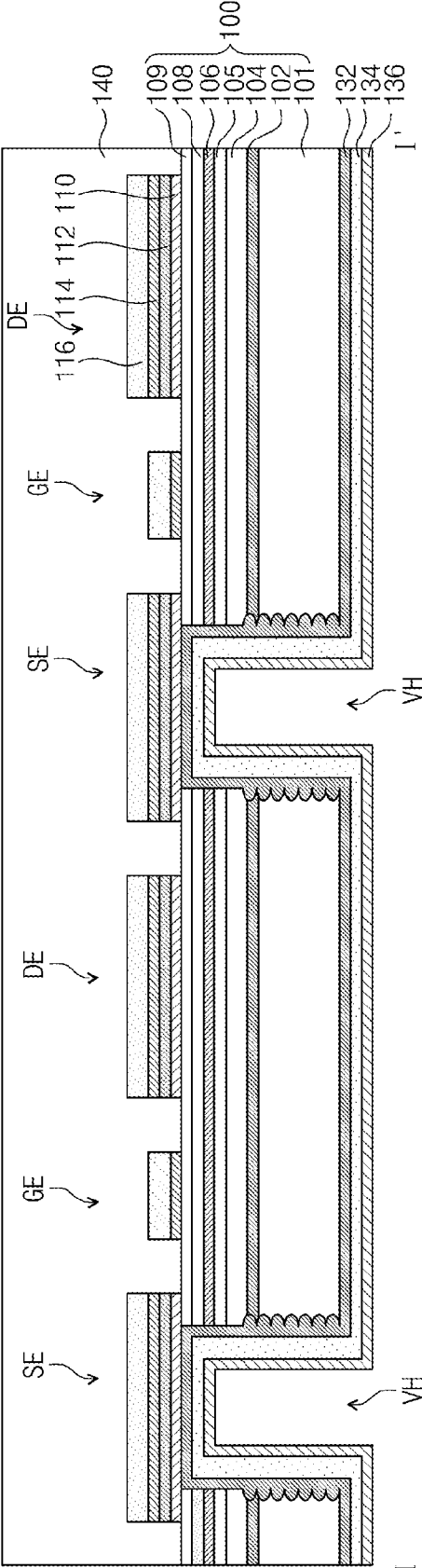

Fig. 2I

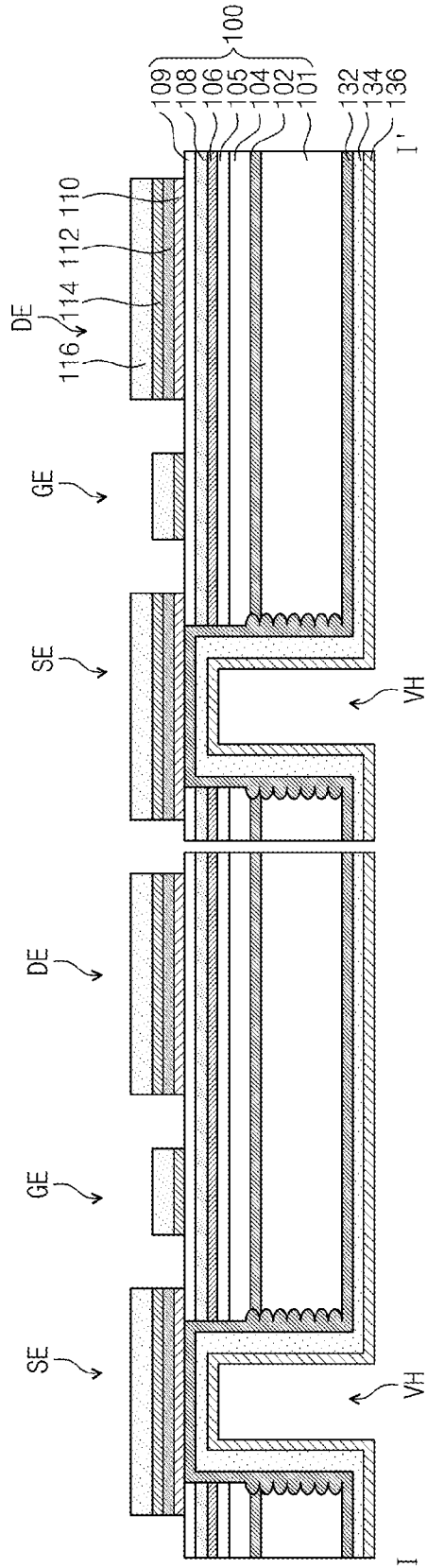

Fig. 3A

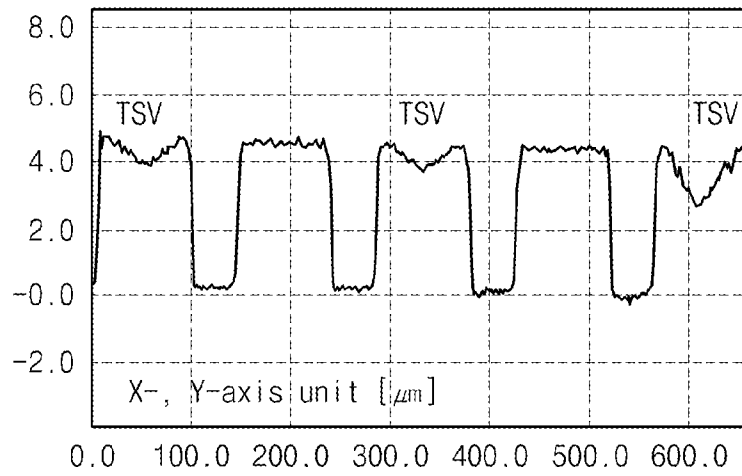
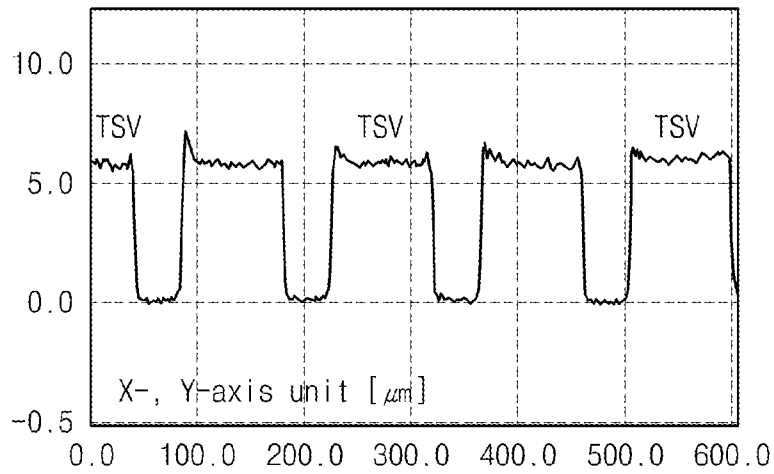

Fig. 3B



SEMICONDUCTOR DEVICE AND METHOD OF MANUFACTURING THE SAME

CROSS-REFERENCE TO RELATED APPLICATIONS

This U.S. non-provisional patent application claims priority under 35 U.S.C. §119 to Korean Patent Application No. 10-2012-0144273, filed on Dec. 12, 2012, the entirety of which is incorporated by reference herein.

BACKGROUND

The inventive concept relates to semiconductor devices and methods of manufacturing the same, more particularly, to semiconductor devices having via-holes and methods of manufacturing the same.

A wafer of a gallium nitride-on-silicon (111) structure may use a bulk silicon substrate as a handle wafer. When compound semiconductor devices and micro-electromechanical system (MEMS) devices having membrane structures are manufactured using the wafer of the gallium nitride-on-silicon (111) structure, polishing techniques such as a chemical mechanical polishing (CMP) technique and a lapping technique are presently used in order that a thickness of a membrane exactly meets a designed numerical value. However, the polishing techniques may require many trials and errors for exactly controlling a thickness of several tens micrometers, such that various problems may occur during processes using the polishing techniques described above.

Meanwhile, through-silicon-via (TSV) techniques have been suggested for manufacturing devices having excellent electrical and thermal characteristics. However, when a TSV is manufactured using a thinned handle wafer, a warpage phenomenon of a wafer may occur. Thus, a remaining stress of the wafer should be controlled and/or a dummy stress buffer layer should be added on the wafer during the process.

SUMMARY

Embodiments of the inventive concept may provide semiconductor devices having excellent electrical and thermal characteristics.

Embodiments of the inventive concept may also provide methods of manufacturing a semiconductor device having excellent electrical and thermal characteristics.

In one aspect, a method of manufacturing a semiconductor device may include: forming devices on a front surface of a substrate, each of the devices including a source electrode, a drain electrode, and a gate electrode, and the substrate including a bulk silicon, a buried oxide layer, an active silicon, a gallium nitride layer, and an aluminum-gallium nitride layer which are sequentially stacked; forming a via-hole penetrating the substrate by etching a back surface of the substrate, the via-hole exposing a bottom surface of the source electrode; conformally forming a ground interconnection on the back surface of the substrate having the via-hole; forming a protecting layer on the front surface of the substrate on which the devices are formed; and cutting the substrate between the devices to separate the devices from each other.

In an embodiment, forming the via-hole may include: forming a mask on the back surface of the substrate; etching the bulk silicon using the mask as an etch mask by a reactive ion etching (RIE) process until the buried oxide layer is exposed; etching the exposed buried oxide layer and the active silicon by a radio frequency (RF) plasma process until the gallium nitride layer is exposed; and etching the exposed

gallium nitride layer and the aluminum-gallium nitride layer by an induced coupled plasma reactive ion etching (ICP RIE) process.

In an embodiment, before forming the via-hole, the method may further include: forming an insulating layer on the front surface of the substrate on which the devices are formed; and bonding a handle wafer to a top surface of the insulating layer.

In an embodiment, the insulating layer may include poly methyl methacrylate (PMMA); and the handle wafer may be bonded to the insulating layer by a wax.

In an embodiment, the method may further include: forming a seed layer on the back surface of the substrate having the via-hole. The ground interconnection may be formed using the seed layer.

In an embodiment, the seed layer may include titanium/copper (Ti/Cu); and the ground interconnection may be formed by a copper plating process.

In an embodiment, the protecting layer may include a photoresist.

In an embodiment, water may be sprayed during the cutting process of the substrate.

In an embodiment, the method may further include: forming a nucleation layer on the active silicon. The gallium nitride layer may be formed by an epitaxial growth process using the nucleation layer as a seed.

In an embodiment, the nucleation layer may include aluminum nitride (AlN).

In an embodiment, the method may further include: forming a capping layer on the aluminum-gallium nitride layer.

In an embodiment, the capping layer may include gallium nitride (GaN).

In another aspect, a semiconductor device may include: a substrate including a bulk silicon, a buried oxide layer, an active silicon, a gallium nitride layer, and an aluminum-gallium nitride layer; a source electrode, a drain electrode, and a gate electrode disposed on a front surface of the substrate; and a ground interconnection disposed along a back surface of the substrate and an inner sidewall of a via-hole penetrating the substrate, the ground interconnection electrically connected to the source electrode.

In an embodiment, the substrate may further include: a nucleation layer between the active silicon and the gallium nitride layer, the nucleation layer including aluminum nitride; and a capping layer on the aluminum-gallium nitride layer, the capping layer including gallium nitride.

In an embodiment, each of the source and drain electrodes may have a stack structure having sequentially stacked titanium, aluminum, nickel, and gold.

In an embodiment, the gate electrode may have a stack structure having sequentially stacked nickel and gold.

In an embodiment, the semiconductor device may further include: a seed layer between the ground interconnection and the back surface of the substrate; and an oxidation preventing layer on the ground interconnection.

In an embodiment, the seed layer may include titanium/copper; the ground interconnection may include copper; and the oxidation preventing layer may include titanium/gold.

BRIEF DESCRIPTION OF THE DRAWINGS

The inventive concept will become more apparent in view of the attached drawings and accompanying detailed description.

FIG. 1A is a plan view illustrating a semiconductor device according to exemplary embodiments of the inventive concept;

FIG. 1B is a cross-sectional view taken along a line I-I' of FIG. 1A;

FIG. 1C is a cross-sectional view illustrating a modified example of a semiconductor device according to exemplary embodiments of the inventive concept;

FIGS. 2A through 2I are cross-sectional views illustrating a method of manufacturing a semiconductor device according to exemplary embodiments of the inventive concept;

FIG. 3A is a graph illustrating a cross section of a via after a cutting process is performed without a protecting layer; and

FIG. 3B is a graph illustrating a cross section of a via after a cutting process is performed on devices covered by a protecting layer.

DETAILED DESCRIPTION OF THE EMBODIMENTS

The inventive concept will now be described more fully hereinafter with reference to the accompanying drawings, in which exemplary embodiments of the inventive concept are shown. The advantages and features of the inventive concept and methods of achieving them will be apparent from the following exemplary embodiments that will be described in more detail with reference to the accompanying drawings. It should be noted, however, that the inventive concept is not limited to the following exemplary embodiments, and may be implemented in various forms. Accordingly, the exemplary embodiments are provided only to disclose the inventive concept and let those skilled in the art know the category of the inventive concept. In the drawings, embodiments of the inventive concept are not limited to the specific examples provided herein and are exaggerated for clarity.

The terminology used herein is for the purpose of describing particular embodiments only and is not intended to limit the invention. As used herein, the singular terms "a," "an" and "the" are intended to include the plural forms as well, unless the context clearly indicates otherwise. As used herein, the term "and/or" includes any and all combinations of one or more of the associated listed items. It will be understood that when an element is referred to as being "connected" or "coupled" to another element, it may be directly connected or coupled to the other element or intervening elements may be present.

Similarly, it will be understood that when an element such as a layer, region or substrate is referred to as being "on" another element, it can be directly on the other element or intervening elements may be present. In contrast, the term "directly" means that there are no intervening elements. It will be further understood that the terms "comprises," "comprising," "includes" and/or "including", when used herein, specify the presence of stated features, integers, steps, operations, elements, and/or components, but do not preclude the presence or addition of one or more other features, integers, steps, operations, elements, components, and/or groups thereof.

Additionally, the embodiment in the detailed description will be described with sectional views as ideal exemplary views of the inventive concept. Accordingly, shapes of the exemplary views may be modified according to manufacturing techniques and/or allowable errors. Therefore, the embodiments of the inventive concept are not limited to the specific shape illustrated in the exemplary views, but may include other shapes that may be created according to manufacturing processes. Areas exemplified in the drawings have general properties, and are used to illustrate specific shapes of elements. Thus, this should not be construed as limited to the scope of the inventive concept.

It will be also understood that although the terms first, second, third etc. may be used herein to describe various elements, these elements should not be limited by these terms. These terms are only used to distinguish one element from another element. Thus, a first element in some embodiments could be termed a second element in other embodiments without departing from the teachings of the present invention. Exemplary embodiments of aspects of the present inventive concept explained and illustrated herein include their complementary counterparts. The same reference numerals or the same reference designators denote the same elements throughout the specification.

Moreover, exemplary embodiments are described herein with reference to cross-sectional illustrations and/or plane illustrations that are idealized exemplary illustrations. Accordingly, variations from the shapes of the illustrations as a result, for example, of manufacturing techniques and/or tolerances, are to be expected. Thus, exemplary embodiments should not be construed as limited to the shapes of regions illustrated herein but are to include deviations in shapes that result, for example, from manufacturing. For example, an etching region illustrated as a rectangle will, typically, have rounded or curved features. Thus, the regions illustrated in the figures are schematic in nature and their shapes are not intended to illustrate the actual shape of a region of a device and are not intended to limit the scope of example embodiments.

FIG. 1A is a plan view illustrating a semiconductor device according to exemplary embodiments of the inventive concept. FIG. 1B is a cross-sectional view taken along a line I-I' of FIG. 1A.

Referring to FIGS. 1A and 1B, a semiconductor device may include a source electrode SE, a gate electrode GE, a drain electrode DE, and a ground interconnection which are formed on a substrate **100**.

The substrate **100** may include a silicon-on-insulator (SOI), a gallium nitride (GaN) layer **106**, and an aluminum-gallium nitride (AlGaN) layer **108** which are sequentially stacked. In an embodiment, the SOI may include a bulk silicon **101**, an buried oxide layer **102**, and an active silicon **104**. In this case, the bulk silicon **101** and the active silicon **104** may have a [111] crystal direction. The SOI may be formed by one of various methods. In an embodiment, a first wafer having the buried oxide layer **102** may be bonded to a second wafer having the active silicon **104** and then the rest portion of the second wafer except the active silicon **104** may be removed from the bonded structure, thereby forming the SOI. In another embodiment, the SOI may be formed by a separation by implanted oxygen (SIMOX) method. That is, oxygen ions may be implanted into a wafer to form the buried oxide layer **102**. A portion of the wafer disposed on the buried oxide layer **102** may correspond to the active silicon **104**, and another portion of the wafer disposed under the buried oxide layer **102** may correspond to the bulk silicon **101**.

In an embodiment, a nucleation layer **105** may be disposed between the SOI (**101**, **102**, and **104**) and the gallium nitride layer **106**. The nucleation layer **105** may include aluminum nitride (AlN).

In an embodiment, a capping layer **109** may be additionally disposed on the aluminum-gallium nitride layer **108**. The capping layer **109** may include gallium nitride (GaN).

In an embodiment, it may be preferable that a thickness of the active silicon **104** of the SOI is controlled to exactly meet a designed numerical value. Thus, it is possible to reduce or minimize mechanical and electrical characteristic variation caused by a thickness difference of the active silicon **104**.

The multi-layered substrate **100** described above may be applied to a radio frequency (RF) power amplifier, a compound power semiconductor, a Schottky barrier diode (SBD), a micro-electromechanical system (MEMS) resonator, and/or a filter. Additionally, the multi-layered substrate **100** may be applied to devices operated in high temperature environment and/or fields requiring compound devices for energy saving.

The source electrode SE, the gate electrode GE, and the drain electrode DE may be disposed on a first surface of the substrate. The source electrode SE, the gate electrode GE, and the drain electrode DE may be disposed to be spaced apart from each other.

In an embodiment, a top surface of the source electrode SE may be disposed at substantially the same level as a top surface of the drain electrode DE. A top surface of the gate electrode GE may be lower than the top surface of the source or drain electrode SE or DE.

The source electrode SE may include a conductive material and may have a multi-layered structure. For example, the source electrode SE may have a titanium (Ti) layer **110**, an aluminum (Al) layer **112**, a nickel (Ni) layer **114**, and a gold (Au) layer **116** which are sequentially stacked.

The drain electrode DE may include a conductive material and may have a multi-layered structure. For example, the drain electrode DE may have a titanium layer **110**, an aluminum layer **112**, a nickel layer **114**, and a gold layer **116** which are sequentially stacked.

The gate electrode GE may be disposed between the source electrode SE and the drain electrode DE. The gate electrode GE may include a conductive material and may have a multi-layered structure. For example, the gate electrode GE may include a nickel layer **114** and a gold layer **116** that are sequentially stacked.

The ground interconnection **134** may be disposed on a second surface of the substrate **100**. The ground interconnection **134** is electrically connected to the source electrode SE.

According to an embodiment of the inventive concept, a via-hole VH exposing a bottom surface of the source electrode SE may be formed at the second surface of the substrate **100**. The via-hole VH may penetrate the substrate **100**. A sidewall of the via-hole VH may have an uneven structure. The ground interconnection **134** may conformally extend along an inner surface of the via-hole VH and may be electrically connected to the source electrode SE.

The ground interconnection **134** may not completely fill the via-hole VH. That is, the ground interconnection **134** may be conformally formed in the via-hole VH. The ground interconnection **134** may include copper (Cu). In an embodiment, a seed layer **132** may be disposed between the ground interconnection **134** and the substrate **100** having the via-hole VH. The seed layer **132** may include titanium/copper (Ti/Cu). In another embodiment, an oxidation preventing layer **136** may be disposed on the ground interconnection **134**. The oxidation preventing layer **136** may prevent the ground interconnection **134** from being oxidized. The oxidation preventing layer **136** may include titanium/gold (Ti/Au).

As described above, since the substrate **100** has the multi-layered structure formed of materials different from each other, a stress applied to the substrate may be reduced during the formation of the via-hole VH. Additionally, since the substrate **100** includes the SOI (**101**, **102**, and **104**), a leakage current characteristic of the semiconductor device may be improved as compared with a device including only bulk silicon.

Moreover, since the ground interconnection **134** is formed on a back surface (e.g., the second surface) of the substrate

100 through the via-hole VH, the semiconductor device may be stably grounded and a heat radiating effect of the semiconductor device may be improved. For example, devices using frequencies equal to or greater than a Ku-band and switching devices may generate heat by switching operation. However, according to embodiments of the inventive concept, the ground interconnection **134** may be formed through the via-hole VH of the back surface, such that the heat radiating effect of the semiconductor device may be greatly improved.

FIG. 1C is a cross-sectional view illustrating a modified example of a semiconductor device according to exemplary embodiments of the inventive concept.

Referring to FIG. 1C, patterns may be formed on the first surface of the substrate **100** in the present modified example. The patterns may include a conductive material. The via-hole VH may be formed at the second surface of the substrate **100**. The via-hole VH may penetrate the SOI (**101**, **102**, and **104**) of the substrate **100**. In other words, the gallium nitride layer **106** may be exposed by the via-hole VH. The semiconductor device illustrated in FIG. 1C may be applied to a MEMS resonator device having a source via grounding structure.

FIGS. 2A through 2I are cross-sectional views illustrating a method of manufacturing a semiconductor device according to exemplary embodiments of the inventive concept.

Referring to FIG. 2A, a substrate **100** may be formed.

In more detail, a SOI (**101**, **102**, and **104**) may be prepared. The SOI (**101**, **102**, and **104**) may include a bulk silicon **101**, a buried oxide layer **102**, and an active silicon **104**. The bulk silicon **101** and the active silicon **104** of the SOI may be formed to have a [111] crystal direction.

A nucleation layer **105** may be formed on the SOI (**101**, **102**, and **104**). The nucleation layer **105** may include aluminum nitride (AlN). A gallium nitride (GaN) layer **106** and an aluminum-gallium nitride (AlGaN) layer **108** may be sequentially formed on the nucleation layer **105** by an epitaxial growth process using the nucleation layer **105** as a seed.

Thus, the substrate **100** may be formed to include the SOI (**101**, **102**, and **104**), the nucleation layer **105**, the gallium nitride layer **106**, and the aluminum-gallium nitride layer **108** which are sequentially stacked.

In an embodiment, a capping layer **109** may be further formed on the aluminum-gallium nitride layer **108**. The capping layer **109** may include gallium nitride (GaN).

Referring to FIG. 2B, a plurality of semiconductor devices may be formed on the substrate **100**. Each of the semiconductor devices may include a source electrode SE, a gate electrode GE, and a drain electrode DE.

In an embodiment, even though not shown in the drawings, dopant regions may be formed by an ion implantation process. Next, a titanium (Ti) layer **110**, an aluminum (Al) layer **112**, a nickel (Ni) layer **114**, and a gold (Au) layer **116** may be sequentially formed and then may be thermally treated at a temperature of about 850 degrees Celsius under a nitrogen atmosphere by a rapid thermal annealing (RTA) process. An ohmic contact may be formed by the RTA process. Thereafter, the layers **110**, **112**, **114**, and **116** may be patterned to form the source electrode SE and the drain electrode DE.

After a nickel layer **114** and a gold layer **116** are sequentially stacked, the layers **114** and **116** may be thermally treated at a temperature of about 350 degrees Celsius under a nitrogen atmosphere and then may be patterned to form the gate electrode GE.

Referring to FIG. 2C, a mask **120** may be formed on a back surface of the substrate **100**.

The mask **120** may include a material having an etch selectivity with respect to the bulk silicon **101** of the SOI of the substrate **100** during an etching process using an etchant. For

example, the mask **120** may include aluminum (Al). The mask **120** may expose the back surface of the substrate **100** which corresponds to the source electrode SE.

Referring to FIG. 2D, an insulating layer **121** and a handle wafer **124** may be formed to cover a front surface of the substrate **100** on which the semiconductor devices are formed.

In an embodiment, the insulating layer **121** may include poly methyl methacrylate (PMMA). After the PMMA is coated at about 2000 rpm, a thermal treatment may be repeatedly performed three or four times at a temperature of about 180 degrees Celsius, thereby forming the insulating layer **121**.

Subsequently, the handle wafer **124** may be bonded using a wax **122** to the insulating layer **121**. The handle wafer **124** may be a sapphire handle wafer.

Referring to FIG. 2E, the bulk silicon **101** of the SOI may be etched using the mask **120** on the back surface of the substrate **100** as an etch mask until the buried oxide layer **102** of the SOI is exposed. Subsequently, the buried oxide layer **120** and the active silicon **104** of the SOI may be sequentially etched to form a preliminary via-hole PVH.

In an embodiment, the bulk silicon **101** of the SOI may be etched by a reactive ion etching (RIE) process. In another embodiment, the bulk silicon **101** of the SOI may be etched by a radio frequency (RF) plasma process using a high RF power. At this time, the buried oxide layer **102** of the SOI may function as an etch stop layer.

Next, the exposed buried oxide layer **102** may be etched by a dry etching process and then the exposed active silicon **104** of the SOI may be etched by the dry etching process. In an embodiment, the dry etching process may be a RF plasma process using a low RF power.

As described above, the bulk silicon **101** of the SOI is etched by the RIE process or the high RF plasma process and then the buried oxide layer **102** and the active silicon **104** may be etched by the low RF plasma process. Thus, an etch stress of the substrate **100** may be reduced or minimized. Additionally, since different material layers are respectively etched using different powers for the formation of the preliminary via-hole PVH, it is possible to prevent the substrate **100** from becoming concave or convex by a remaining stress of a via-hole VH formed in a subsequent process or by a compressive stress and a tensile stress of the multi-layer.

Referring to FIG. 2F, the nucleation layer **105** exposed by the preliminary via-hole PVH, the gallium nitride layer **106**, and the aluminum-gallium nitride layer **108** may be etched to form a via-hole VH.

In an embodiment, the nucleation layer **105**, the gallium nitride layer **106**, and the aluminum-gallium nitride layer **108** may be etched by an induced coupled plasma reactive ion etching (ICP RIE) process.

If the capping layer **109** is disposed on the aluminum-gallium nitride layer **108** according to another embodiment, the capping layer **109** may also be etched by the ICP RIE process.

Thus, the via-hole VH may completely penetrate the substrate **100**. Additionally, the via-hole VH may expose at least a portion of a bottom surface of the source electrode SE.

Referring to FIG. 2G, a ground interconnection **134** may be conformally formed on the back surface of the substrate **100** having the via-hole VH.

In an embodiment, in the first place, a seed layer **132** may be conformally formed on the back surface of the substrate **100** having the via-hole VH. The seed layer **132** may include titanium/copper (Ti/Cu).

Subsequently, the ground interconnection **134** may be formed by an electroplating process using the seed layer **132**. The ground interconnection **134** may include copper (Cu). The ground interconnection **134** may have a thickness of about 10 μm .

In an embodiment, an oxidation preventing layer **136** may be formed on the ground interconnection **134** for preventing the ground interconnection **134** from being oxidized. The oxidation preventing layer **136** may include titanium/gold (Ti/Au).

Next, the handle wafer **124** and the insulating layer **121** may be removed. After the handle wafer **124** is removed, a cleaning process using trichloroethene (TCE) and acetone may be performed to remove the insulating layer **121**.

Referring to FIG. 2H, a protecting layer **140** may be formed on the front surface of the substrate **110** on which the semiconductor devices are formed. The protecting layer **140** may include a photoresist.

Referring to FIG. 2I, the semiconductor devices may be separated from each other by a cutting process.

Water may be sprayed during the cutting process. The protecting layer **140** of FIG. 2H may prevent the semiconductor devices from being damaged by water pressure during the cutting process. In particular, if the cutting process is performed without the protecting layer **140**, the source electrode SE connected to the ground interconnection **134** may be more damaged. Thus, the damage of the source electrode SE may be prevented due to the protecting layer **140**. After the cutting process is performed, the protecting layer **140** may be removed.

FIG. 3A is a graph illustrating a cross section of a via after a cutting process is performed without a protecting layer, and FIG. 3B is a graph illustrating a cross section of a via after a cutting process is performed on devices covered by a protecting layer.

Referring to FIG. 3A, a height difference of a concave shape occurs at a top end of the via. Referring to FIG. 3B, a top end of the via is substantially flat. Thus, it is confirmed that the stress is applied to the via if the cutting process is performed without the protecting layer **140**.

According to embodiments of the inventive concept, the source electrode is connected to the ground interconnection through the back surface via-hole formed in the substrate. Thus, the heat radiating effect of the semiconductor device may be improved. Additionally, the different materials from each other of the substrate may be etched by different powers from each other, respectively. Thus, the etch stress caused during the process may be reduced. As a result, the semiconductor device having excellent electrical and thermal characteristics may be realized.

While the inventive concept has been described with reference to example embodiments, it will be apparent to those skilled in the art that various changes and modifications may be made without departing from the spirit and scope of the inventive concept. Therefore, it should be understood that the above embodiments are not limiting, but illustrative. Thus, the scope of the inventive concept is to be determined by the broadest permissible interpretation of the following claims and their equivalents, and shall not be restricted or limited by the foregoing description.

What is claimed is:

1. A method of manufacturing a semiconductor device, the method comprising:

forming devices on a front surface of a substrate, each of the devices including a source electrode, a drain electrode, and a gate electrode, and the substrate including a bulk silicon, a buried oxide layer, an active silicon, a

9

gallium nitride layer, and an aluminum-gallium nitride layer which are sequentially stacked;
 forming a via-hole penetrating the substrate by etching a back surface of the substrate, the via-hole exposing a bottom surface of the source electrode;
 conformally forming a ground interconnection on the back surface of the substrate having the via-hole;
 after forming the via-hole and the ground interconnection, forming a protecting layer on the front surface of the substrate on which the devices are formed; and
 after forming the protecting layer, cutting the substrate between the devices to separate the devices from each other, wherein the protecting layer is disposed on the front surface of the substrate while the cutting of the substrate.

2. The method of claim 1, wherein forming the via-hole comprises:
 forming a mask on the back surface of the substrate;
 etching the bulk silicon using the mask as an etch mask by a reactive ion etching (RIE) process until the buried oxide layer is exposed;
 etching the exposed buried oxide layer and the active silicon by a radio frequency (RF) plasma process until the gallium nitride layer is exposed; and
 etching the exposed gallium nitride layer and the aluminum-gallium nitride layer by an induced coupled plasma reactive ion etching (ICP RIE) process.

3. The method of claim 1, before forming the via-hole, further comprising:
 forming an insulating layer on the front surface of the substrate on which the devices are formed; and
 bonding a handle wafer to a top surface of the insulating layer.

4. The method of claim 3, wherein the insulating layer includes poly methyl methacrylate (PMMA); and

10

wherein the handle wafer is bonded to the insulating layer by a wax.

5. The method of claim 1, further comprising:
 forming a seed layer on the back surface of the substrate having the via-hole,
 wherein the ground interconnection is formed using the seed layer.

6. The method of claim 5, wherein the seed layer includes titanium/copper (Ti/Cu); and
 wherein the ground interconnection is formed by a copper plating process.

7. The method of claim 1, wherein the protecting layer includes a photoresist.

8. The method of claim 1, wherein water is sprayed during the cutting process of the substrate.

9. The method of claim 1, further comprising:
 forming a nucleation layer on the active silicon,
 wherein the gallium nitride layer is formed by an epitaxial growth process using the nucleation layer as a seed.

10. The method of claim 9, wherein the nucleation layer includes aluminum nitride (AlN).

11. The method of claim 1, further comprising:
 forming a capping layer on the aluminum-gallium nitride layer.

12. The method of claim 11, wherein the capping layer includes gallium nitride (GaN).

13. The method of claim 1, wherein a handle wafer is formed to cover the front surface of the substrate after forming the devices and before forming the via-hole, and the handle wafer is removed before forming the protecting layer.

14. The method of claim 1, wherein a top surface of the gate electrode is lower than a top surface of each of the source and drain electrodes.

* * * * *