

May 17, 1938.

J. M. HOTHERSALL

2,117,324

CONTAINER

Filed Dec. 11, 1935

Fig. 1

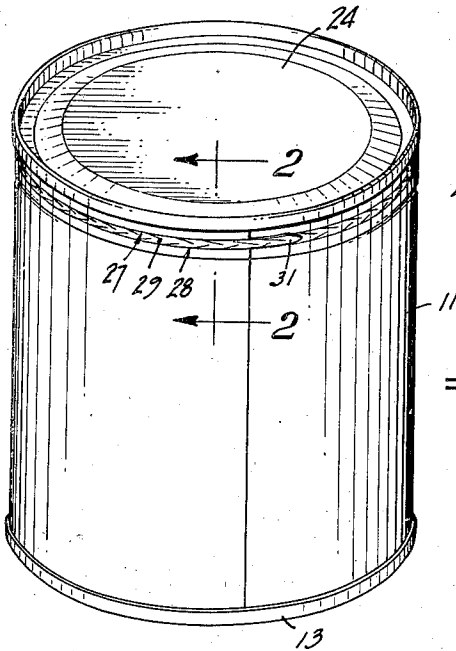

Fig. 2

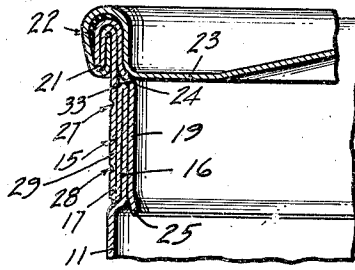

Fig. 4

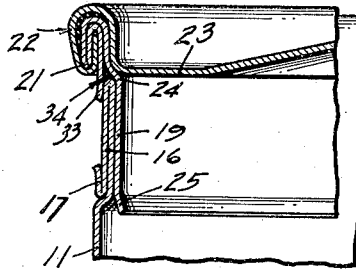

Fig. 3

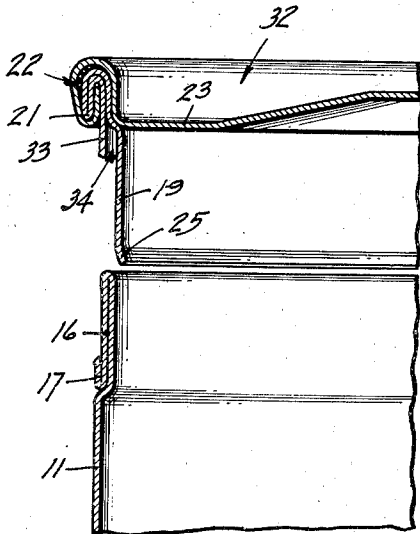
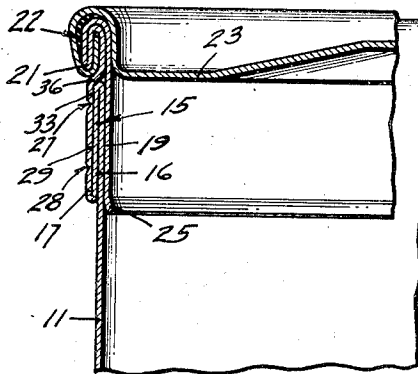

Fig. 5



INVENTOR
John M. Hothersall
BY *Wm. R. Thornburgh*
Charles H. Fine
ATTORNEYS

UNITED STATES PATENT OFFICE

2,117,324

CONTAINER

John M. Hothersall, Brooklyn, N. Y., assignor to
American Can Company, New York, N. Y., a
corporation of New Jersey

Application December 11, 1935, Serial No. 53,973

6 Claims. (Cl. 220—54)

The present invention relates to a sheet metal container or can adapted to be opened by the removal of a tearing strip which is formed in a wall of a folded collar band section of the body and has particular reference to a can having a flange member secured in place within the seam joining the body to its top so that removal of the tearing strip produces a reclosure cover having this flange being adapted to frictionally engage the collar band of the can.

An object of the invention is the provision of a container having a tearing strip formed in a folded collar band section of the body and having a flange member secured in place within the seam uniting the body to its top wherein removal of the tearing strip produces a reclosure cover having a flange adapted to utilize the collar band as a friction base for holding the cover in place on the container when it is used as a reclosure.

Another object is the provision of such a container wherein the flange member is formed from the material of the container body by folding the body wall back on itself and into engagement with the collar band, the folded flange member being incorporated in the seam uniting the body to its top so that removal of the tearing strip leaves the flange member connected with the can top to produce the desired flanged reclosure cover, thereby making it possible to use the same simple form of can ends for both top and bottom instead of a different and more expensive special can top having the required flange wall formed therein and which would require more tin plate and would result in a greater waste of material.

Still another object is the provision of a container of this character wherein a wall section left by removal of the tearing strip from the folded section of the body, taken together with the flange member, provide spaced flanges setting off an intervening pocket for sealing engagement over the top edge of the collar band when the cover is used as a reclosure.

Numerous other objects and advantages of the invention will be apparent as it is better understood from the following description, which, taken in connection with the accompanying drawing, discloses a preferred embodiment thereof.

Referring to the drawing:

Figure 1 is a perspective view of a tearing strip container embodying the instant invention and showing the container prior to opening;

Fig. 2 is an enlarged transverse sectional view showing a fragment of the upper end of the closed container, the view being taken substantially along the line 2—2 in Fig. 1;

Fig. 3 is an enlarged fragmentary sectional view similar to Fig. 2 showing the parts after the tearing strip has been removed and showing the

flanged cover produced thereby and in separated relation to the opened can;

Fig. 4 is an enlarged fragmentary sectional view similar to Figs. 2 and 3 showing the flanged cover applied to the opened can and in use as a reclosure; and

Fig. 5 is an enlarged fragmentary sectional view similar to Fig. 2 illustrating a modified form of the invention.

The container or can illustrated in the drawing as a preferred embodiment of the invention comprises a tubular body 11 (Fig. 1) having a bottom end 13 secured thereto in any suitable manner.

At the upper end of the can the body side wall is folded outwardly and downwardly upon itself and then upward as in a double fold to provide a folded section or band 15 of triple thickness or layers of body material extending around the body, as shown in Fig. 2. The two inner layers of the band form a smooth edged internal collar 16 which is surrounded by the outer layer (designated by the numeral 17) which is preferably set back flush with the body wall so that the exterior surface of the can will be smooth and straight.

The outer layer 17 of the band 15 extends above the top edge of the collar 16 and is folded back on itself providing an annular wall or flange member 19 which extends back from a fold or top edge 21 which is flanged over in the usual manner and incorporated in a suitable seam 22 which permanently unites a can top end 23 with the body 11. The flange member 19 extends down inside the body adjacent the inner surfaces of the outer wall 17 and the collar band 16, the member being bent as at 24 to overlap the top edge of the collar band. The flange member preferably terminates adjacent the lower end of the collar band in an inwardly flared edge 25.

Spaced below the seam 22 in the outer layer 17 of the folded section 15 are parallel score lines 27, 28 defining a tearing strip 29 extending around the body. One end of the tearing strip terminates in a tearing tongue 31 adapted for engagement by a key or other suitable tool for removing the strip in the usual manner to open the container.

Removal of the tearing strip 29 produces a flanged can cover 32 (Fig. 3) which may now be lifted off the can to open the same. This cover includes the can top 23, the flange member 19 and an upper wall section 33 formed by removal of the tearing strip from the outer layer 17. The member 19 which originally was a folded part of the body wall now provides a flange for the cover and is adapted to fit within the collar band 16 utilizing the latter as a friction base when the cover is used as a reclosure (Fig. 4). This form of cover flange permits the use of the same ordinary can end for the top that is used for the bottom instead of a more expensive and special form of can top having friction walls formed therein.

The wall section 33 is adapted to engage the exterior surface of the collar band, the upper edge of the latter being disposed in a pocket 34 (Figs. 3 and 4) provided between the flange member 19 and the wall section 33. The reclosure cover 32 is thus adapted to seat tightly over the top edge of the collar band to prevent accidental displacement of the cover and to protect the interior of the can against the entrance of foreign matter.

Fig. 5 of the drawing discloses a modified form of the invention in which the folded section 15 is formed on the outside of the body to provide a container having a straight internal wall instead of a straight external wall as illustrated in the other figures. In this form of container the inside layer of the collar band 16 is a continuation of and is in alignment with the body wall 11 and at the top this wall is folded outwardly and downwardly against the outside of the body to form the outside wall of the collar band and is thence folded outwardly and upwardly to form the outer wall 17.

The outer layer 17 embodying the tearing strip 29 extends above the collar band 16 and is bent inwardly as at 36 to engage over the top of the collar and to align with the body wall 11. The upper end of the layer 17 extends up into the top seam 22 where it merges into the fold 21 and the flange member 19. In this form the flange member 19 extends straight down into the body and lays flat against the inner surface of the body wall.

Removal of the tearing strip in the usual manner produces the flanged cover 32 in which the wall section 33 is again preferably present and in which the member 19 is again the inner flange as described in connection with the straight external wall container of Figs. 1 to 4, inclusive. In like manner this flange 19 is adapted to engage within the collar band and the wall section 33 is adapted to engage the outside of the collar band in the same way when the cover is used as a reclosure. This form of the invention, like the form disclosed hereinbefore, permits the use of the same ordinary can end for the top that is used for the bottom instead of a more expensive and special form of can top having friction walls formed therein.

It is thought that the invention and many of its attendant advantages will be understood from the foregoing description, and it will be apparent that various changes may be made in the form, construction and arrangement of the parts without departing from the spirit and scope of the invention or sacrificing all of its material advantages, the form hereinbefore described being merely a preferred embodiment thereof.

I claim:

1. A sheet metal container, comprising a body having a tearing strip formed in a side wall thereof, an internal collar band formed integrally with said side wall, an end closure permanently joined to said body, and an annular flange member integrally formed with said body side wall and embraced in the seam connecting said end closure to said body, said flange member providing a cover flange utilizing said collar band as a friction base for supporting the reclosure cover produced by removal of said tearing strip.

2. A sheet metal container, comprising a tubular body having its side wall folded to produce an outer layer, an inner flange member and a plurality of intermediate layers the outer layer and the inner flange member projecting above

the intermediate layers, a container top secured to said outer layer and said flange member, and score lines formed in said outer layer and defining a tearing strip having a tearing tongue for removing said tearing strip, the removal of said tearing strip producing a cover having connected thereto said flange member which was originally a part of said body side wall and which now serves as a flange for the cover and the flange utilizing said intermediate body layers as a friction base for holding said cover in place when it is used as a reclosure.

3. A sheet metal container, comprising a tubular body having its side wall folded to produce an outer layer, an inner flange member and a plurality of intermediate layers, the outer layer and the inner flange member projecting above the intermediate layers the while preserving a straight external wall to the body, a container top secured to said outer layer and said flange member, and score lines formed in said outer layer and defining a tearing strip which when removed leaves said flange member connected with said top and which thereby produces a flange for a reclosure cover the flange being adapted to frictionally engage said intermediate body layers when the cover is in container closing position.

4. A sheet metal container, comprising a tubular body having its side wall folded to produce an outer layer, an inner flange member and a plurality of intermediate layers the outer layer and the inner flange member projecting above the intermediate layers the while preserving a straight internal wall to the body, a container top secured to said outer layer and said flange member, and score lines formed in said outer layer and defining a tearing strip which when removed leaves said flange member connected with said top and which thereby produces a flange for a reclosure cover the flange being adapted to frictionally engage said intermediate body layers when the cover is in container closing position.

5. A sheet metal container, comprising a body having its side wall formed into a plurality of layers providing an internal collar band for the container, a tearing strip in the outer of said layers, an end closure seamed to an extension of one of said layers, and an annular flange member secured within said seam and extending into said body adjacent said collar band, said layer extension together with said flange member providing spaced friction flanges defining an intervening sealing pocket for the reclosure cover produced by the removal of said tearing strip said spaced flanges being adapted to frictionally engage the sides and receive an edge of said collar band for holding said cover in sealing engagement on the container when the cover is used as a reclosure.

6. A sheet metal container, comprising a body having a multiplicity of layers adjacent one end, a tearing strip defined by score lines in the outer of said layers, an end closure seamed to an extension of one of said layers, said extension being continued into said seam and thence back on itself depending from said seam adjacent said layers to form a reclosure cover flange on said end closure, the latter being produced by removal of said tearing strip, said flange engaging within the innermost of said layers at one end of the body.

JOHN M. HOTHERSALL,