



(22) Date de dépôt/Filing Date: 2003/11/18

(41) Mise à la disp. pub./Open to Public Insp.: 2005/05/18

(51) Cl.Int.⁷/Int.Cl.⁷ B65D 55/16

(71) Demandeur/Applicant:
LEPOSAVIC, NATALIA, CA

(72) Inventeur/Inventor:
LEPOSAVIC, NATALIA, CA

(54) Titre : BOUTEILLE A PAROI RETENANT LE BOUCHON REUTILISABLE

(54) Title: BOTTLE WITH WALL THAT HOLDS ITS REUSABLE STOPPER

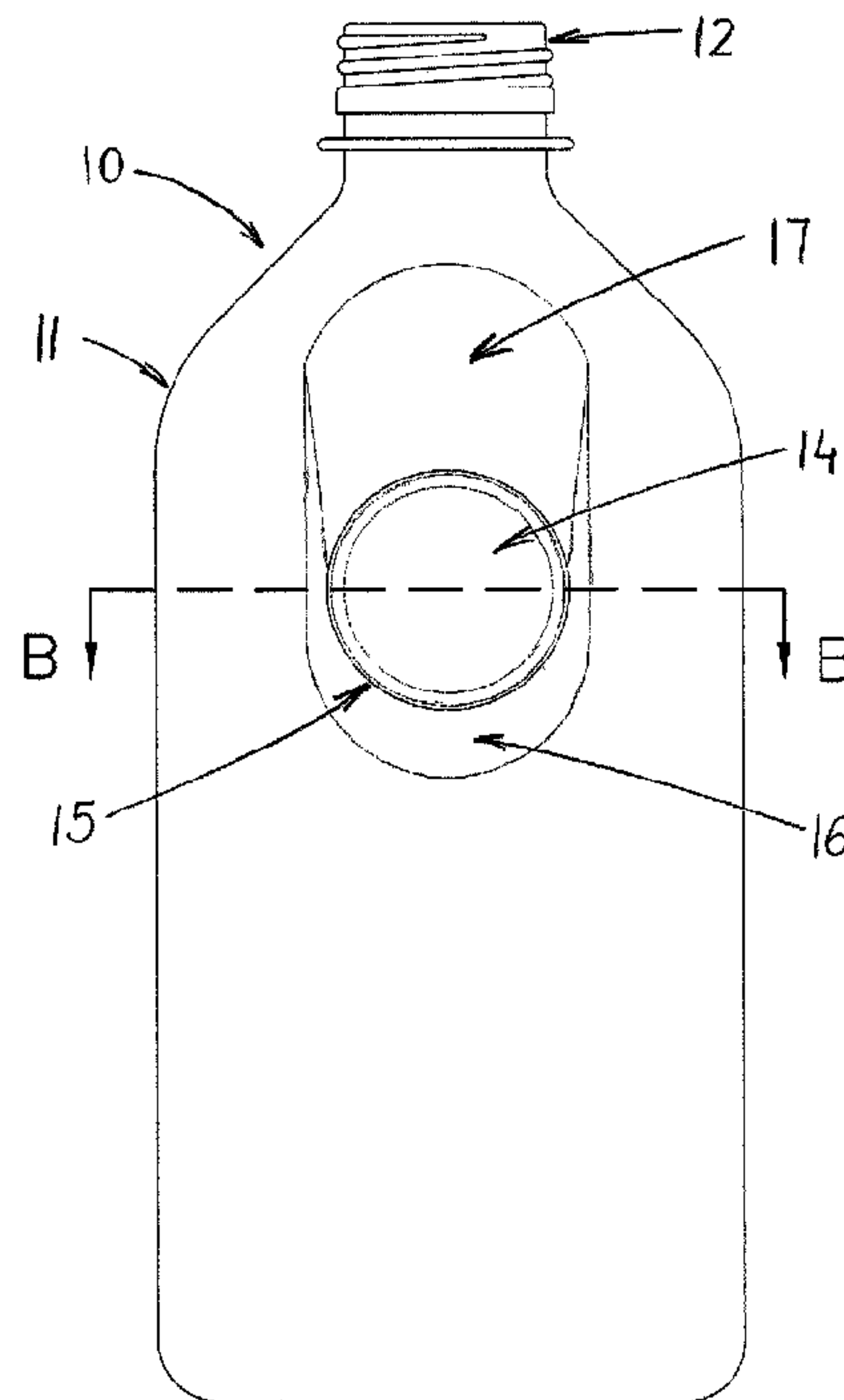

(57) **Abrégé/Abstract:**

Bottle (10) having an improved bottle wall (11) capable to hold its reusable stopper (14) while keeping bottle's upright stability. The bottle walls are forming bay with cup like seat that holds stopper in place using elastic properties of plastic materials used for bottle and stopper, and friction between surfaces of bottle and stopper. The bay has a shallow and wide entry (17) on the top. From the entry point, going down, the bay gains depth and becomes narrower towards the low bay point, so stopper (14) can find its way into the cup-like seat easily. After the wide entry, stopper's circumference is getting in touch with the inner walls of the recess (15) that are from that point gently conical. With further travel of stopper, until it is completely positioned within the bay, the holding of a stopper is achieved by elastic deformation and friction between stopper (14) and bottle's recessed walls (15). Conical walls at the bay bottom may be slightly widened (relaxed) so "click" sensation is achieved when stopper slides in.. This shape provides easy placing of stopper in the recessed wall (bay) from the top and room for fingers at low point (16) to take the stopper out.



ABSTRACT

Bottle (10) having an improved bottle wall (11) capable to hold its reusable stopper (14) while keeping bottle's upright stability. The bottle walls are forming bay with cup like seat that holds stopper in place using elastic properties of plastic materials used for bottle and stopper, and friction between surfaces of bottle and stopper.

The bay has a shallow and wide entry (17) on the top. From the entry point, going down, the bay gains depth and becomes narrower towards the low bay point, so stopper (14) can find its way into the cup-like seat easily. After the wide entry, stopper's circumference is getting in touch with the inner walls of the recess (15) that are from that point gently conical. With further travel of stopper, until it is completely positioned within the bay, the holding of a stopper is achieved by elastic deformation and friction between stopper (14) and bottle's recessed walls (15). Conical walls at the bay bottom may be slightly widened (relaxed) so "click" sensation is achieved when stopper slides in..

This shape provides easy placing of stopper in the recessed wall (bay) from the top and room for fingers at low point (16) to take the stopper out.

BOTTLE WITH WALL THAT HOLDS ITS REUSABLE STOPPER

BACKGROUND OF THE INVENTION

This invention relates to containers, for liquids or granule like material, that we commonly call bottles. It relates to all sorts of bottles designed to contain pressurized or non-pressurized liquids and granule like materials. More particularly it concerns a bottle, which has stopper that can close the bottle after opening (reusable stopper).

Since the invention of bottle with reusable stoppers, many attempts have been made to find the way of temporary keeping the stopper safe and secure while the bottle is in use (open). Loosing the stopper would result in problem how to close the bottle and keep the remaining bottle content for future use. Also, holding stopper in one hand and bottle in another is usually very inconvenient, while putting stopper in a pocket or elsewhere, is not hygienic or safe solution. Person, with open bottle in one hand and stopper in the other, has difficulty in doing any other activity.

Solutions that we have seen to date usually have stopper attached to the bottleneck with strip of plastic, or leather strip (flask), or wire (beer), or chain (military/camping water bottles).

None of these solutions solved following problems:

1. dangling stopper is not hygienically protected
2. liquid residues drip from the stopper
3. annoying dangling stopper while person use the bottle

With increased popularity of bottles with reusable stoppers, which are giving us benefit of drinking bottle content over extended period of time, instead at once (like cans), there is a need for bottles that will hold stopper in hygienic way, and at the same time requiring use of only one hand while drinking from the bottle. Benefits of such bottle can also be utilized for bottles for cleaning products, medical supplies, etc.

All before mentioned problems are resolved with this invention - bottle with wall shaped to hold its reusable stopper.

SUMMARY OF THE INVENTION

The intention and purpose of the invention will be set forth in part in the description which follows, and in part will be obvious from the description and drawings, or may be learned by practice of the invention. The advantages and purpose of the invention will be realized and attained by elements and combinations particularly pointed out in the appended claims.

To attain the advantages and in accordance with purpose of the invention, as embodied and broadly described herein, the invention include a bottle that has a wall shaped in the way to entirely or in part accommodate and hold temporarily the reusable stopper while a person use the bottle.

The innovation is to design bottle wall in the way to entirely or in part accommodate and hold stopper while keeping bottle's upright stability. Design of the wall is done in such way that stopper could easily be placed in and taken out with fingers.

Holding stopper by the wall is achieved by creating forms in the bottle wall and by using friction and elastic properties of materials that stopper and bottle are made of. Bottle walls are holding stopper at multiple points, or multiple sections of circumference, or one section of circumference equal or greater than 180° , or combination of the above.

Holding of the stopper by the bottle wall can be improved further by increasing friction between elements by finishing stopper and/or bottle base with material that has better friction and/or by creating grooves and bumps, on one or on both surfaces.

In some cases, like rigid and/or very low surface friction materials, the above discussed improvements may be necessary to achieve holding of the stopper by the bottle wall.

The above mentioned finishing, if applied on a stopper, will also improve the grip needed for opening and closing the bottle.

It is to be understood that both, the foregoing general description and the following detailed description, are exemplary and explanatory only and are not restrictive of the invention, as claimed.

BRIEF DESCRIPTION OF THE DRAWINGS

The accompanying drawings which are incorporated in and constitute a part of this specification, illustrate some embodiments of the invention, like bottles and stoppers for pressurized and non pressurized liquids and granule like material, and together with the description, serve to explain the principles of the invention and are not to be understood as restrictive.

Drawing description:

Fig.1.a is a side elevation of bottle with vertical bays in the wall, one holding stopper.

Fig.1.b is a vertical cross section A-A of bottle of Fig.1.a.

Fig.1.c is a horizontal cross section B-B of bottle of Fig.1.a.

Fig.2.a is a side elevation of bottle with slots in the wall, one holding stopper.

Fig.2.b is a vertical cross section C-C of bottle of Fig.2.a.

Fig.2.c is a horizontal cross section D-D of bottle of Fig.2.a.

Fig.3.a is a side elevation of bottle showing bottle wall with one full height vertical slot holding stopper.

Fig.3.b is a vertical cross section E-E of bottle of Fig.3.a.

Fig.3.c is a horizontal cross section F-F of bottle of Fig.3.a.

Fig.4.a is a side elevation of bottle with five vertical slots and one horizontal depression in the wall, one of the slots holding stopper.

Fig.4.b is a vertical cross section G-G of bottle of Fig.4.a.

Fig.4.c is a horizontal cross section H-H of bottle of Fig.4.a.

DESCRIPTION OF THE PREFERRED EMBODIMENTS

The bottles of different shapes, sizes, and materials, which are in use today, are designed to meet requirements for different: contents, filling processes, transport, storage and use. Intention of this invention is to establish improved design of the bottle wall, so bottle, beside its present function, is capable of holding bottle stopper in safe and hygienic way while the bottle is in use (open). Term bottle wall, in the following text, stands for entire part of the bottle between bottle base and bottle dispensing opening. All types of bottles with reusable stoppers can be improved with this invention.

However, different bottle shapes, sizes, and materials would need different detailed design of the bottle wall and in some cases stopper as well. Therefore, the choice of four types of preferred embodiments as plastic bottles is made for explanatory and presentation purposes. They are selected in the way to show utilization of present invention on the most common bottles and stoppers used today, and are not to be understood as restrictive.

The design of the bottle wall will be determined mostly by the type of contents (pressurized or non-pressurized), materials used for the bottle and the stopper (their elasticity and surface friction) and size of the stopper and bottle (diameter and height). Also, bottles designed for pressurized contents can be used, in general, for non-pressurized contents, while bottles for non-pressurized contents, in general, can not be used for pressurized contents.

Reference will now be made in detail to the present preferred embodiments of the invention, example of which are illustrated in the accompanying drawings. The following are the description of four different types of preferred embodiments of the present invention:

1. Preferred Embodiment for bottle with vertical bays in the wall:

The following preferred embodiment represents recessed wall solution for bottle and is only one of many possible options and is not to be understood as restrictive.

Referring specifically to Fig.1.a, 1.b, and 1.c that show hollow plastic bottle (10) of the present invention, said bottle includes a generally round wall (11) with a dispensing opening (12) which is configured for a suitable stopper (14) which is shown being held in place by the bottle wall recess on Fig.1.a and cross sections A-A on Fig. 1.b and B-B on Fig.1.c. The bottle has recessed wall in the "U" shape (15) that forms bay in this example. Cross section of recess in the wall forms cup like seat that holds stopper in place using elastic properties of plastic materials used for bottle and stopper, and friction between surfaces of bottle and stopper.

This shape provides easy placing of stopper in the recessed wall (bay) from the top and room for fingers at low point (16) to take the stopper out.

The bay has a shallow and wide entry (17) on the top, seen in cross section on Fig.1.a. From the entry point, going down, the bay gains depth and becomes narrower towards the low bay point, so stopper (14) can find its way into the cup-like seat easily. After the wide entry, stopper's circumference is getting in touch with the inner walls of the recess (15) that are from that point gently conical. With further travel of stopper, until it is completely positioned within the bay, the holding of a stopper is achieved using elastic deformation and friction between stopper and bottle's recessed walls (15) as seen in the cross section B-B on Fig.1.c.

Conical walls at the bay bottom may be slightly widened (relaxed) so "click" sensation is achieved when stopper slides in. This example shows two recesses on opposite sides of the bottle, however, one recess is sufficient for the function of this invention and more than two are possible solutions as well.

Tapering angle (β) of the recessed seat will depend on elastic properties and friction coefficient of materials used for the stopper and the bottle.

2. Preferred Embodiment for bottle with vertical slot in the wall:

Bottle shown on Fig.2.a, Fig.2.b, and Fig.2.c is similar in shape to the bottle described above, but instead of bay, it has a slot, so that reusable stopper can be put in and taken out both ways (up and down). At the position (18) which is designated for the temporary holding of a stopper, conical walls are slightly widened (relaxed) so "click" sensation is achieved when stopper slides in. It is designed as oval with two holding sections on the opposite sides and recess that allows taking stopper both ways (up or down) or pulling straight out.

By rotating above described design by 90^0 , different look (horizontal slot) but similar results, in performance and benefits of present invention, would be achieved.

3. Preferred Embodiment for bottle with full height vertical slot in the wall:

Bottle shown on Fig.3.a, Fig.3.b, and Fig.3.c is similar to the bottle described above but has a full height vertical shallow slot. Reusable stopper can also be put in and taken out both ways. At the position (18) which is designated for temporary holding of stopper (19), conical walls are slightly relaxed so "click" sensation is achieved when stopper slides in. Detail (18) is repeated three times so it makes it easier to place stopper in temporary holding position. It is designed as oval with two holding sections on the opposite sides and recess that allows taking stopper both ways.

Shallow slot design is possible because of groove (20), shown in cross sections E-E and F-F, that is matching and accommodating bulge on stopper's outer circumference (21).

This design is seen as good solution for bottles for drugs, cosmetics, and cleaning products, but is not restrictive to any other use.

4. Preferred Embodiment for bottle for pressurized content:

Referring specifically to Fig.4.a, 4.b, and 4.c that show hollow plastic bottle (10) of the present invention, said bottle includes a generally cylindrical side wall (11), dispensing opening (12) configured to hold a suitable stopper (19) which is shown being held in place by bottle slot and its groove in the wall (24) which is shown in vertical cross section in Fig.4.b and horizontal cross section Fig 4.c.

The bottle wall beside multiple vertical slots (five slots in this preferred and explanatory embodiment to match ordinary number of projected feet on bottles for pressurized content) has one horizontal narrow depression ('waist line'), that forms structural grid with vertical slots to stand the inner pressure and provide bottle shape stability.

Intersection of slot and 'waist line' makes at the same time a relaxation point for stopper's designated temporary holding position. The stopper, when placed in temporary holding position is hold at four points and as in the case of the third preferred embodiment, has bulge (21) on outer circumference to improve holding and allow shallow slot design (with grooved walls).

Number of horizontal 'waist lines' and vertical slots is restrictive only by the size of the bottle.

Rotating above described design by 90^0 , and applying on the bottle of same size and shape, would result in horizontal slots and narrow vertical depressions. However, different look but similar results, in performance and benefits of present invention, would be achieved.

It is apparent that the embodiments shown in the figures from Fig. 1.a through to Fig. 4.c are only a few of the many possible variations according to this invention, among which it will be possible to also select based on the particular size and styling characteristics offered by each different embodiment.

It will be appreciated that what has been afore said and shown, with reference to the accompanying drawings, has only been set forth by mare way of example of the present invention and its improvements, and that it may therefore be the subject of any modifications considered to be appropriate without departing from the scopes of the invention.

CLAIMS

- 1.) Bottle, of any size, shape or material, with a wall that can temporary hold bottle's reusable stopper while the stopper is off its dispensing opening.
- 2.) The bottle of claim 1 wherein the recessed bottle wall is formed as a bay, or slot, or round, or oval, or multi-petal, or star-like, or any combination of the above shapes to achieve holding of its reusable stopper.
- 3.) The bottle of claim 1 wherein the bottle wall is formed by projected grooves or bulges in different configurations to achieve holding of its reusable stopper, regardless of number of projected grooves or bulges.
- 4.) Holding stopper in the bottle wall by creating cup-like seat in the bottle wall and by using friction and elastic properties of materials that stopper and bottle are made of. Bottle recessed walls and/or projected wall forms are holding stopper at multiple points, or multiple sections of circumference, or one section of circumference equal or greater than 180° , or full circumference, or any combination of the above.
- 5.) Improve holding of the stopper of claim 4 by increasing friction between elements and elasticity by finishing stopper and/or bottle wall with material that has better friction and/or elasticity on one or on both surfaces.
- 6.) Improve holding of the stopper of claim 4 by creating matching profiles (grooves and bulges) at holding points of bottle wall and stopper.
- 7.) Improve ease of placement of the reusable stopper in designated temporary holding place by creating multiple holding places in the same slot.

Fig. 1.a.

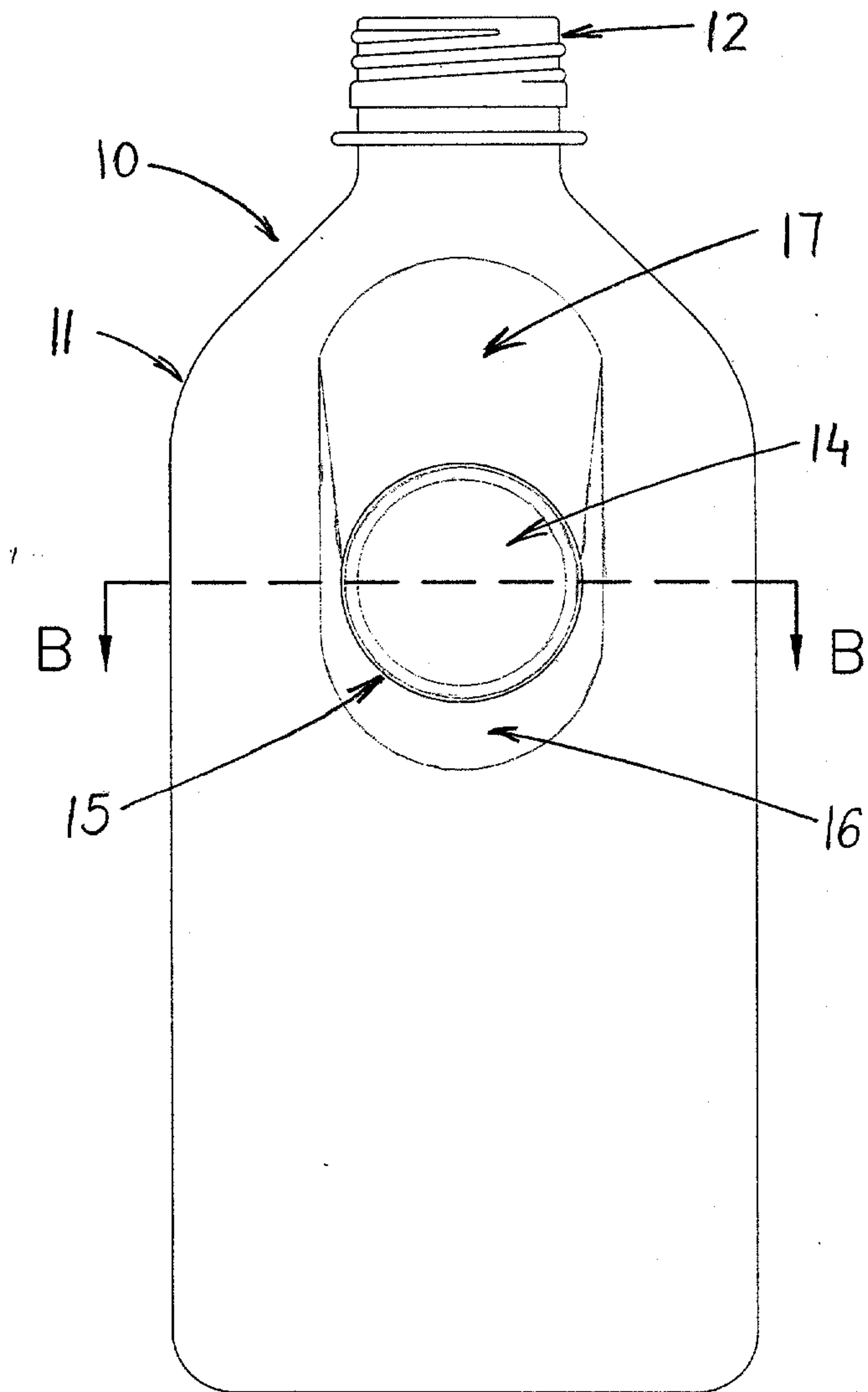

Fig. 1.b. (A-A)

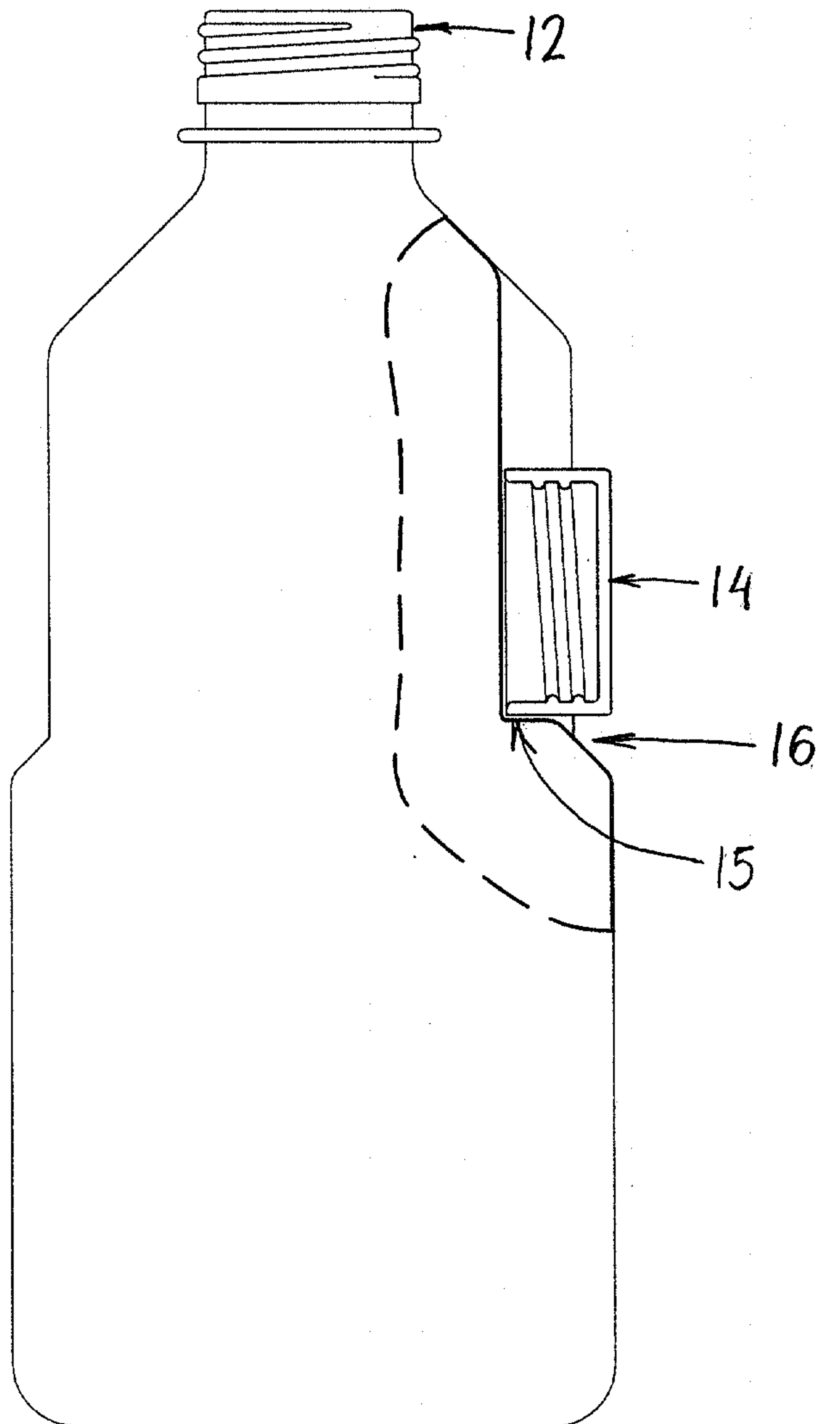

Fig. 1.c. (B-B)

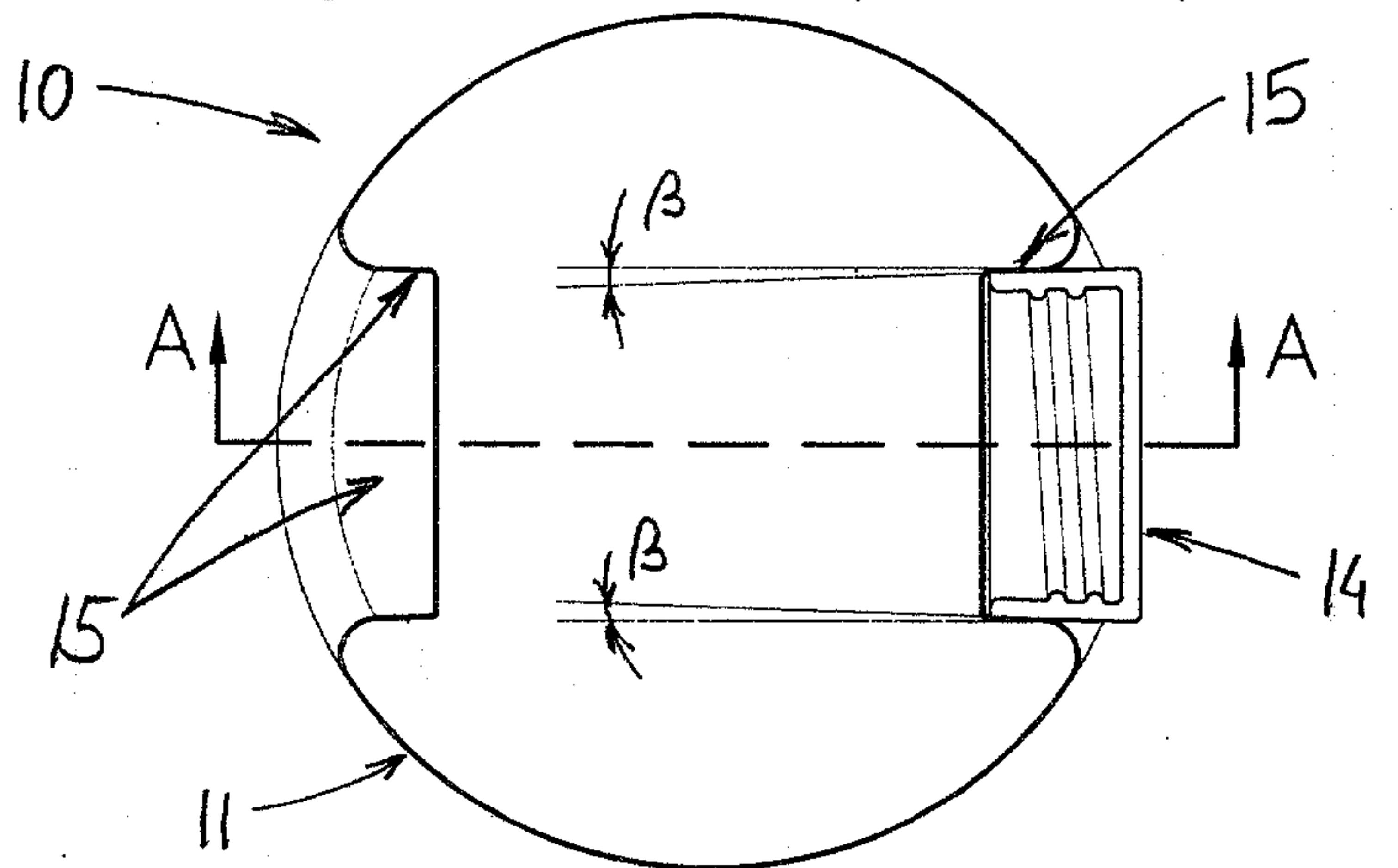

Fig. 2.a.

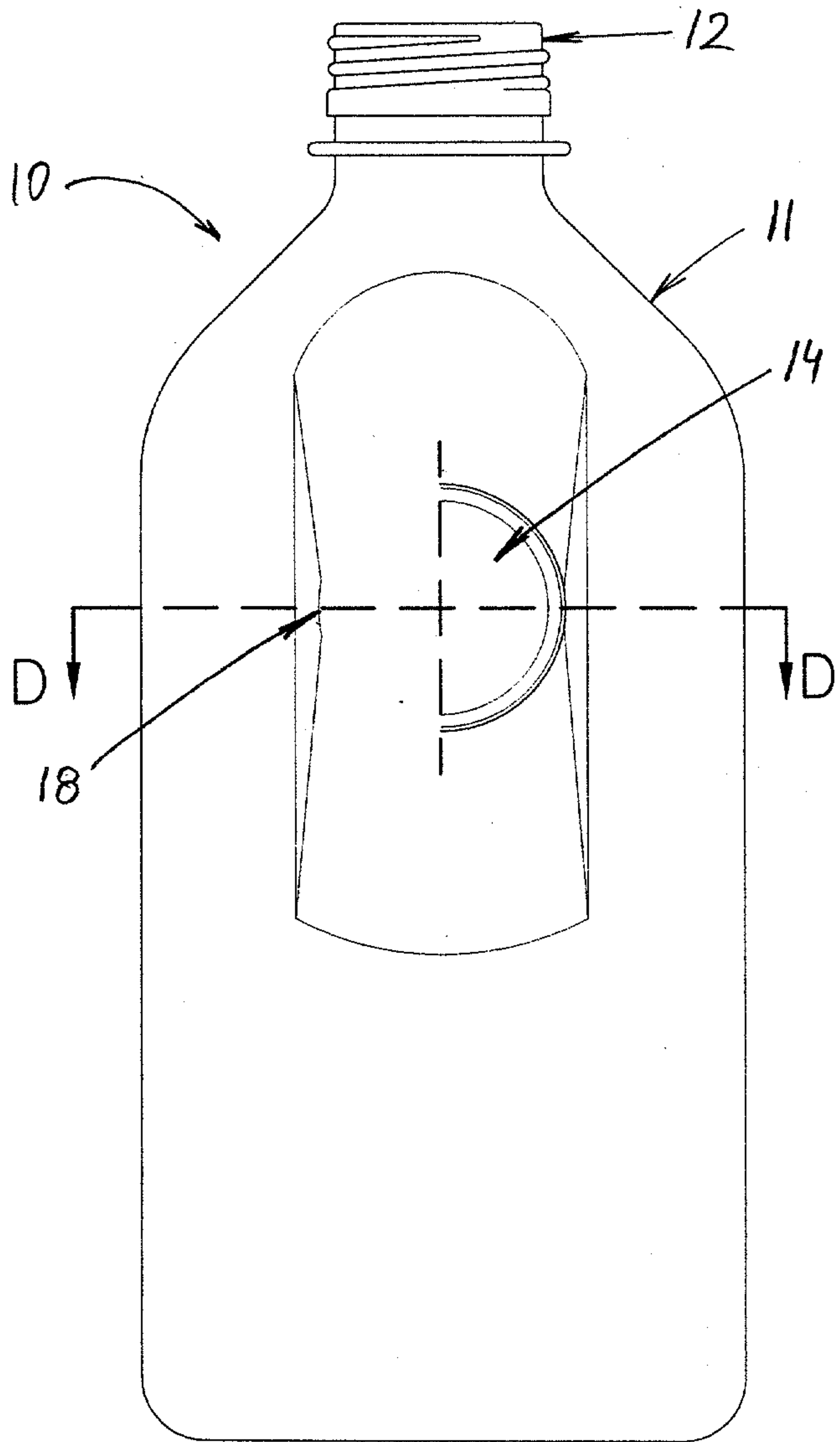

Fig. 2.b. (C-C)

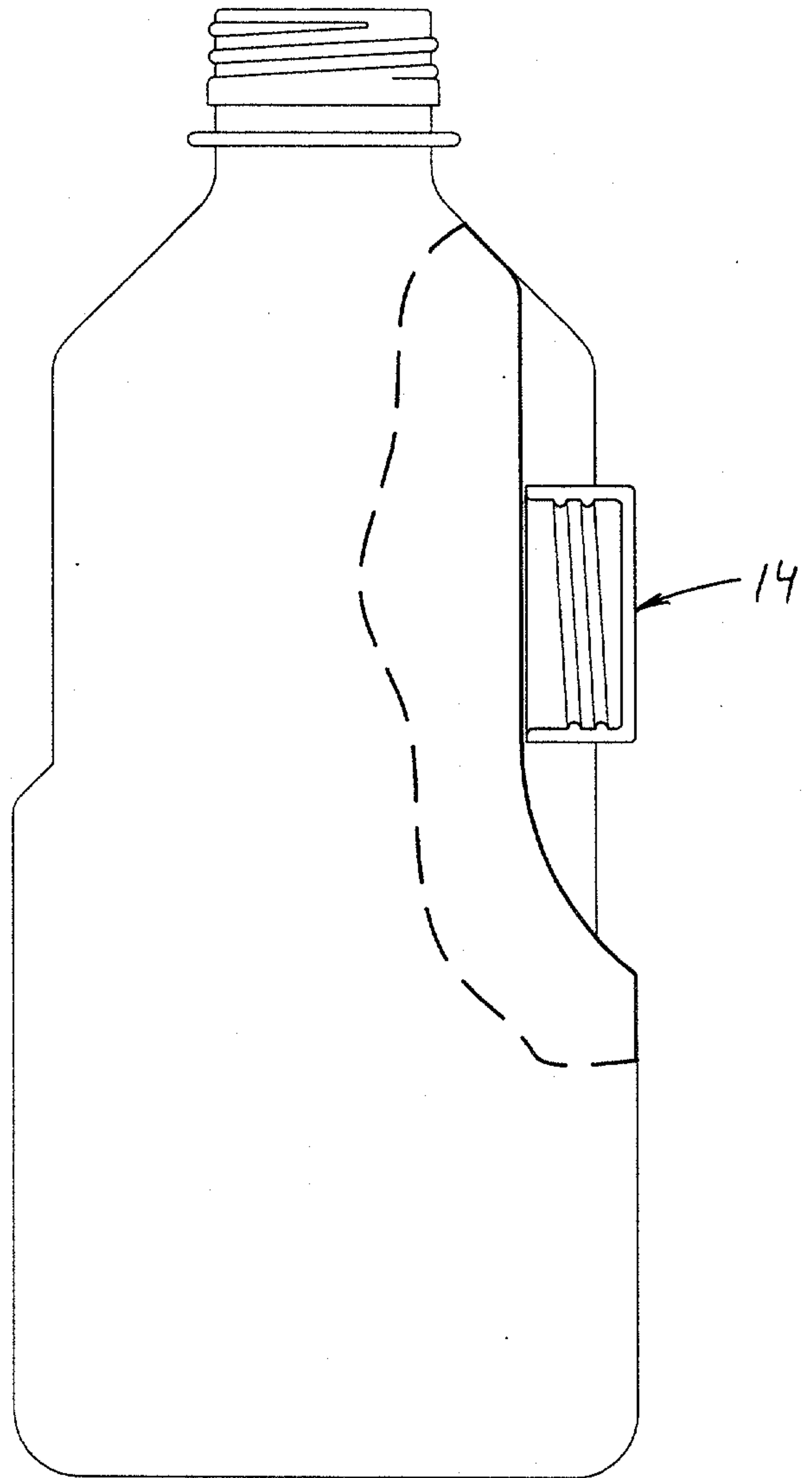

Fig. 2.c. (D-D)

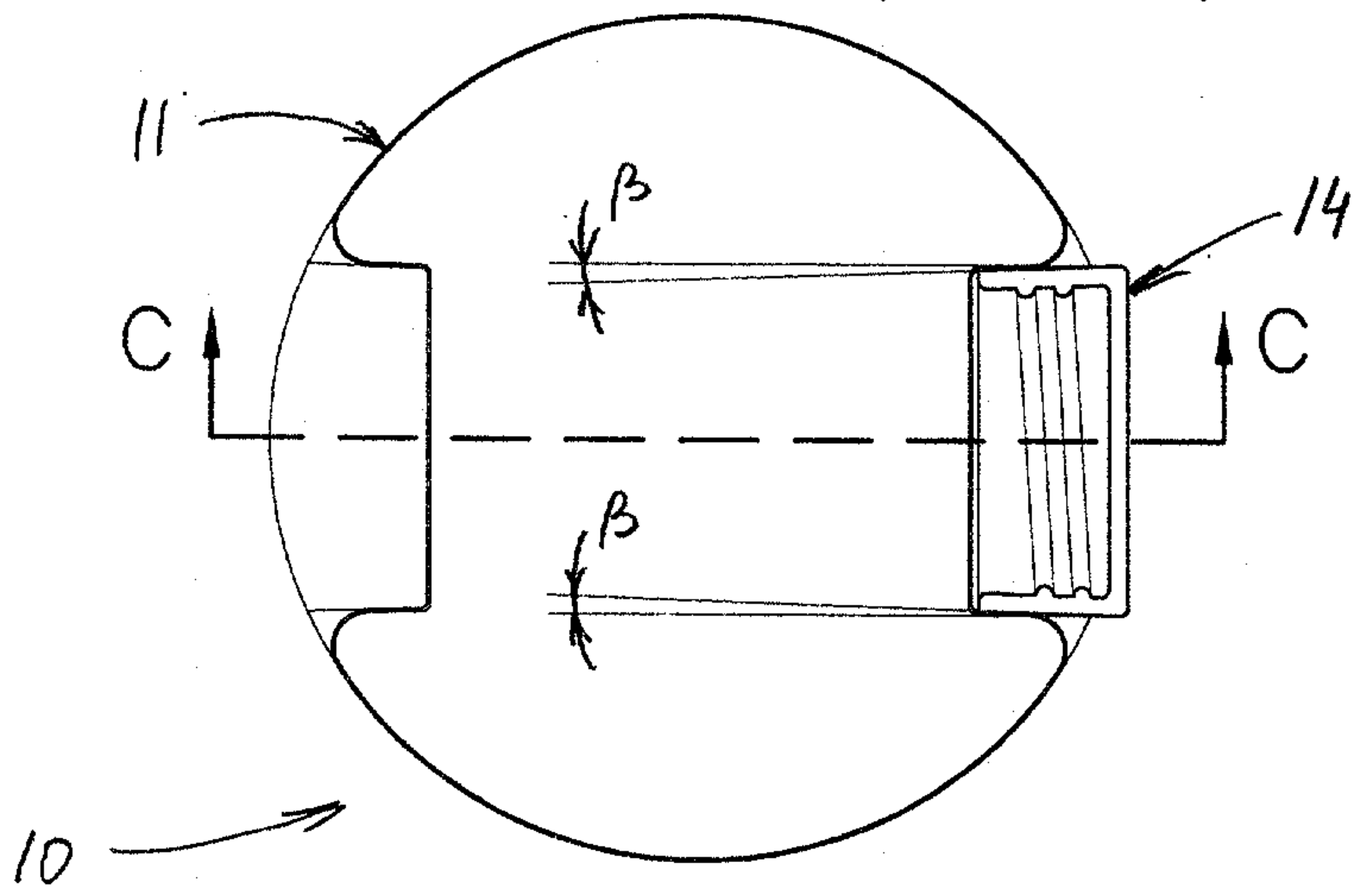

Fig. 3.a.

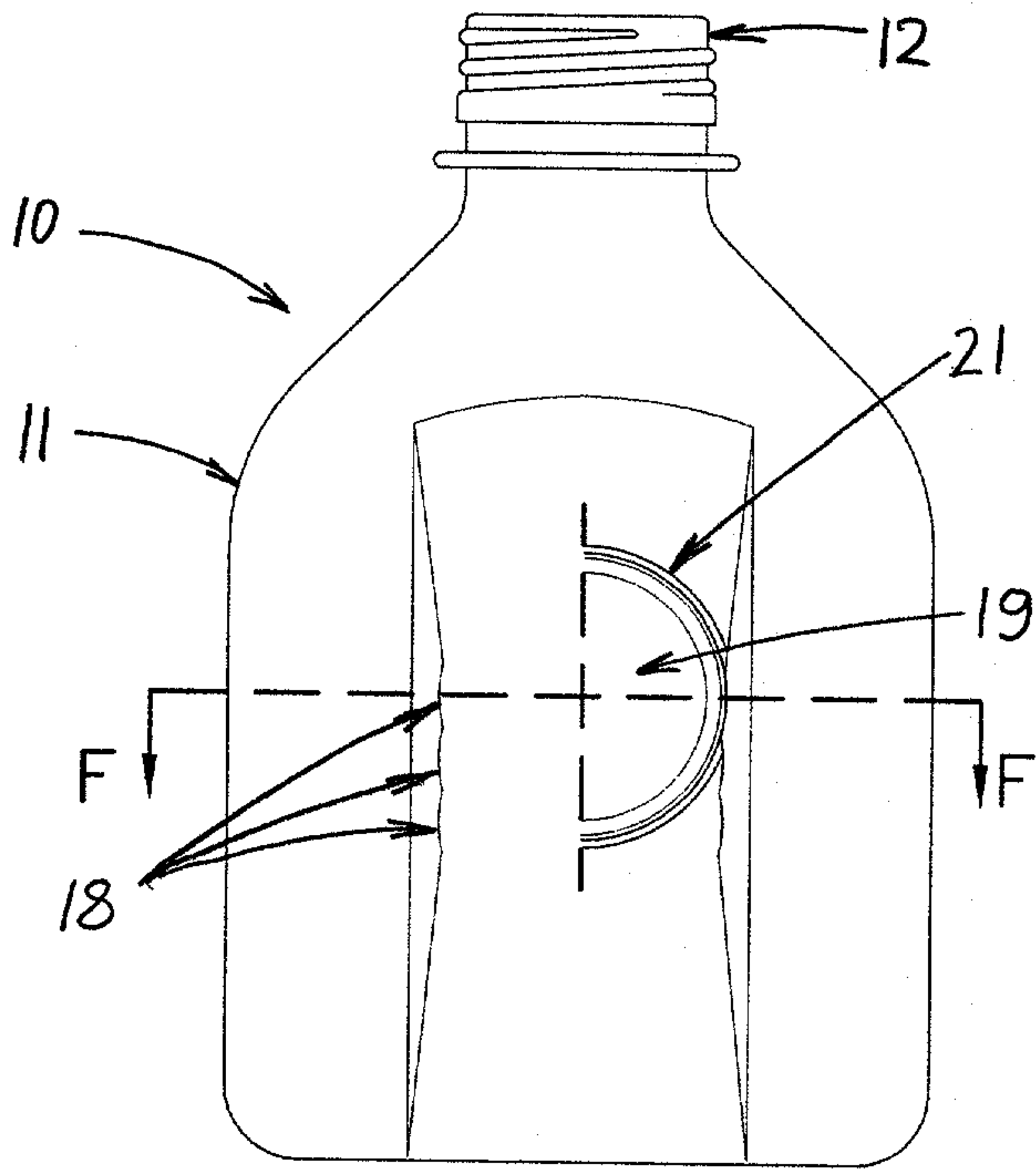

Fig. 3.b. (E-E)

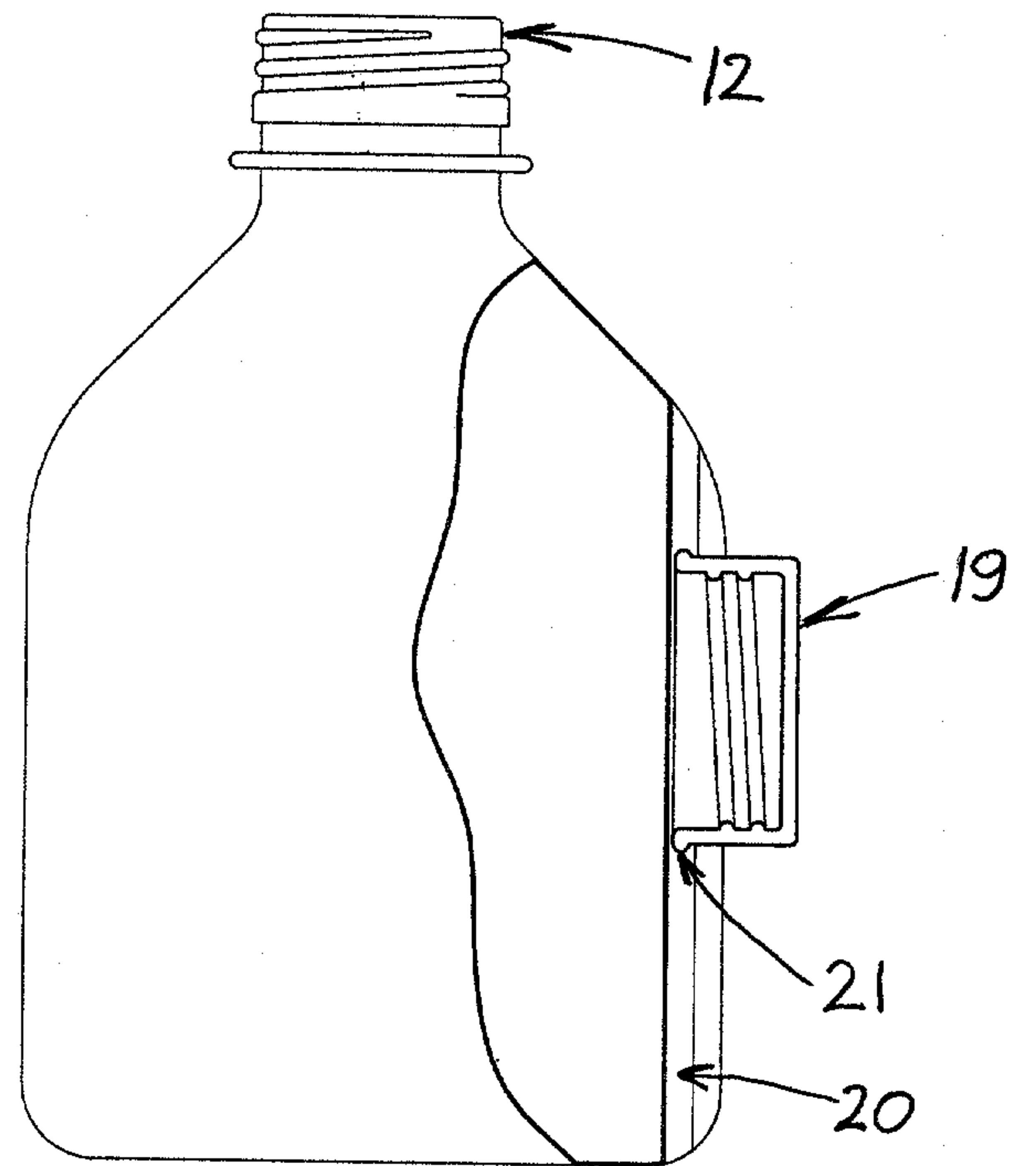

Fig. 3.c. (F-F)

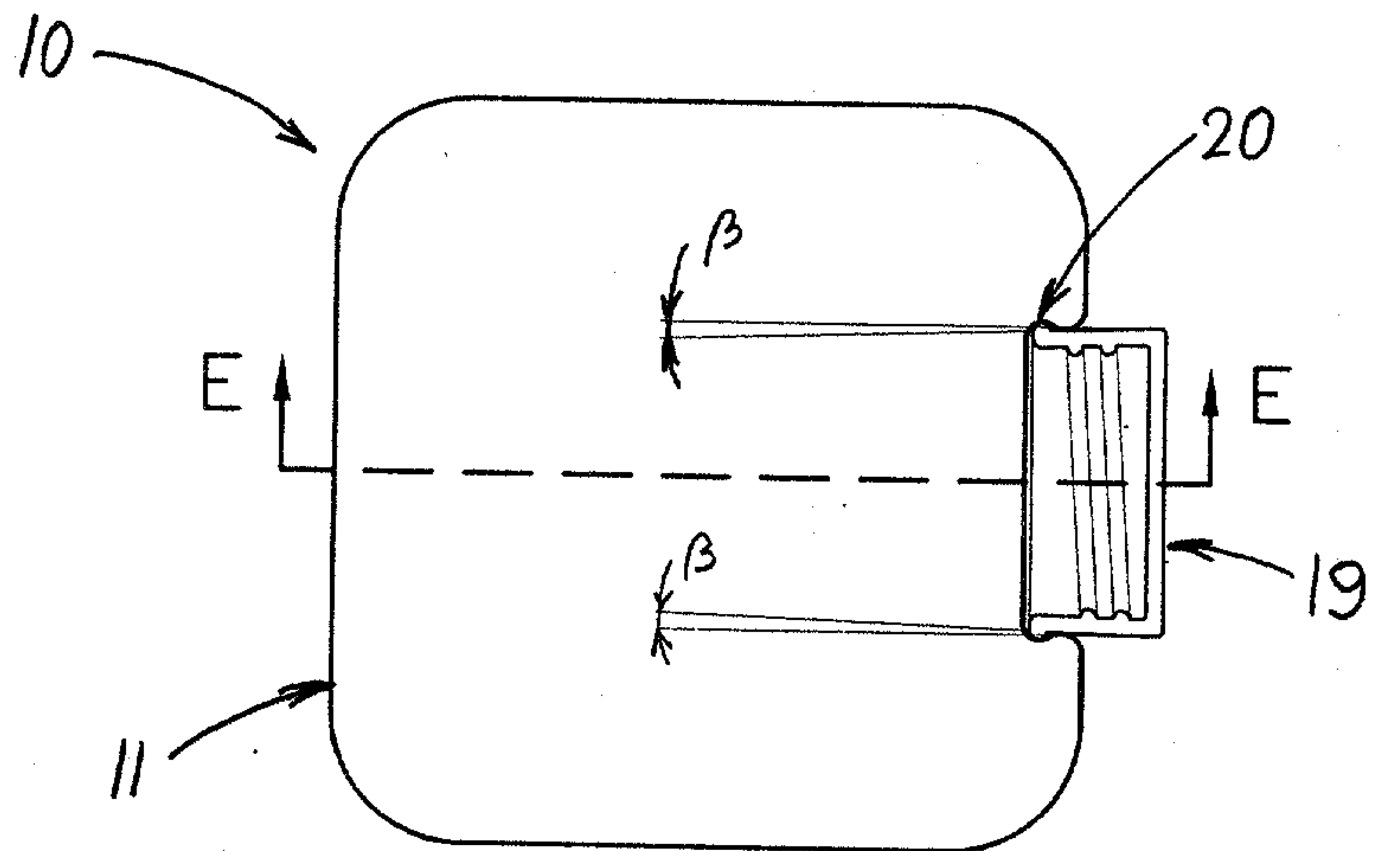

Fig. 4.a.

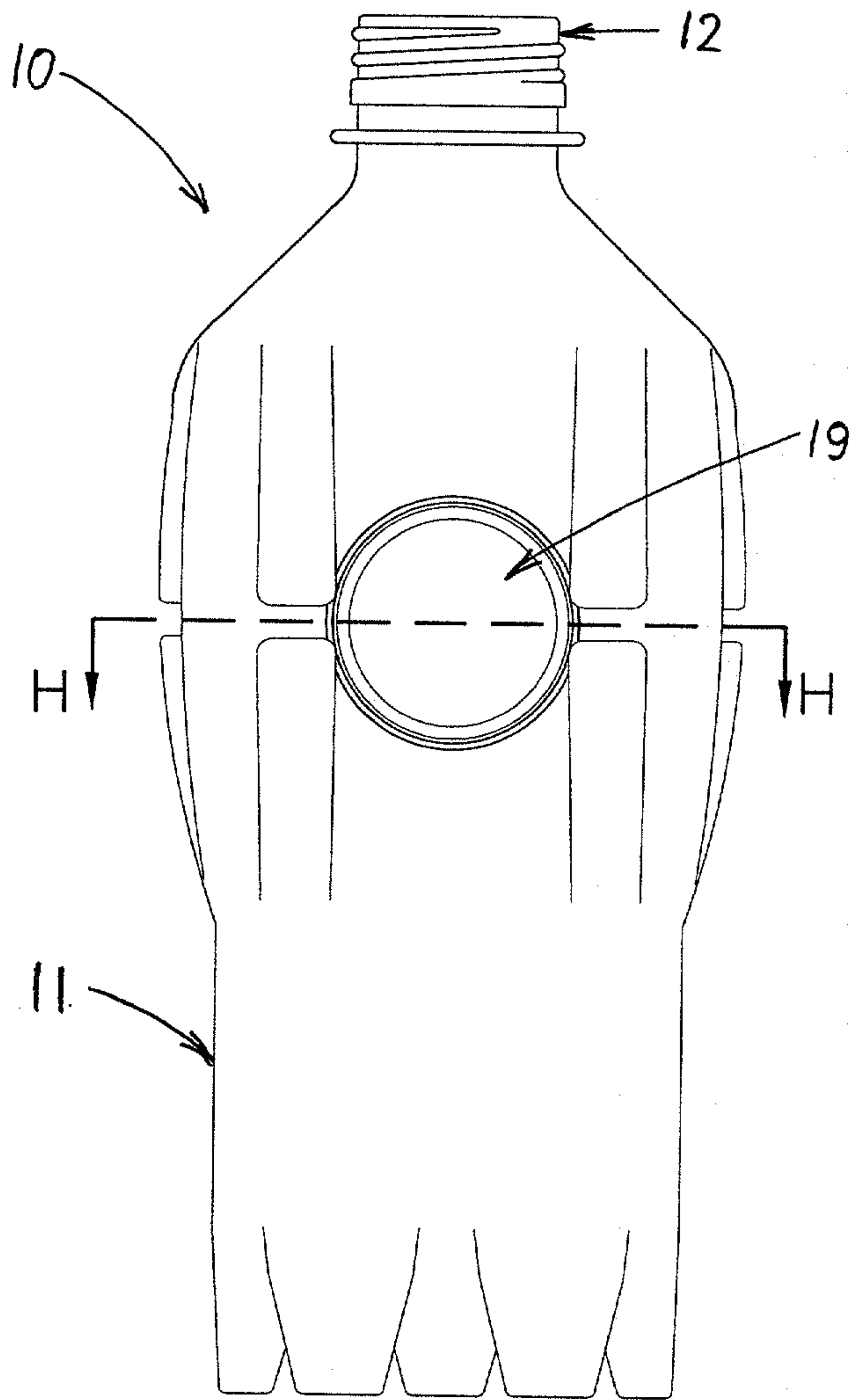

Fig. 4.b. (G-G)

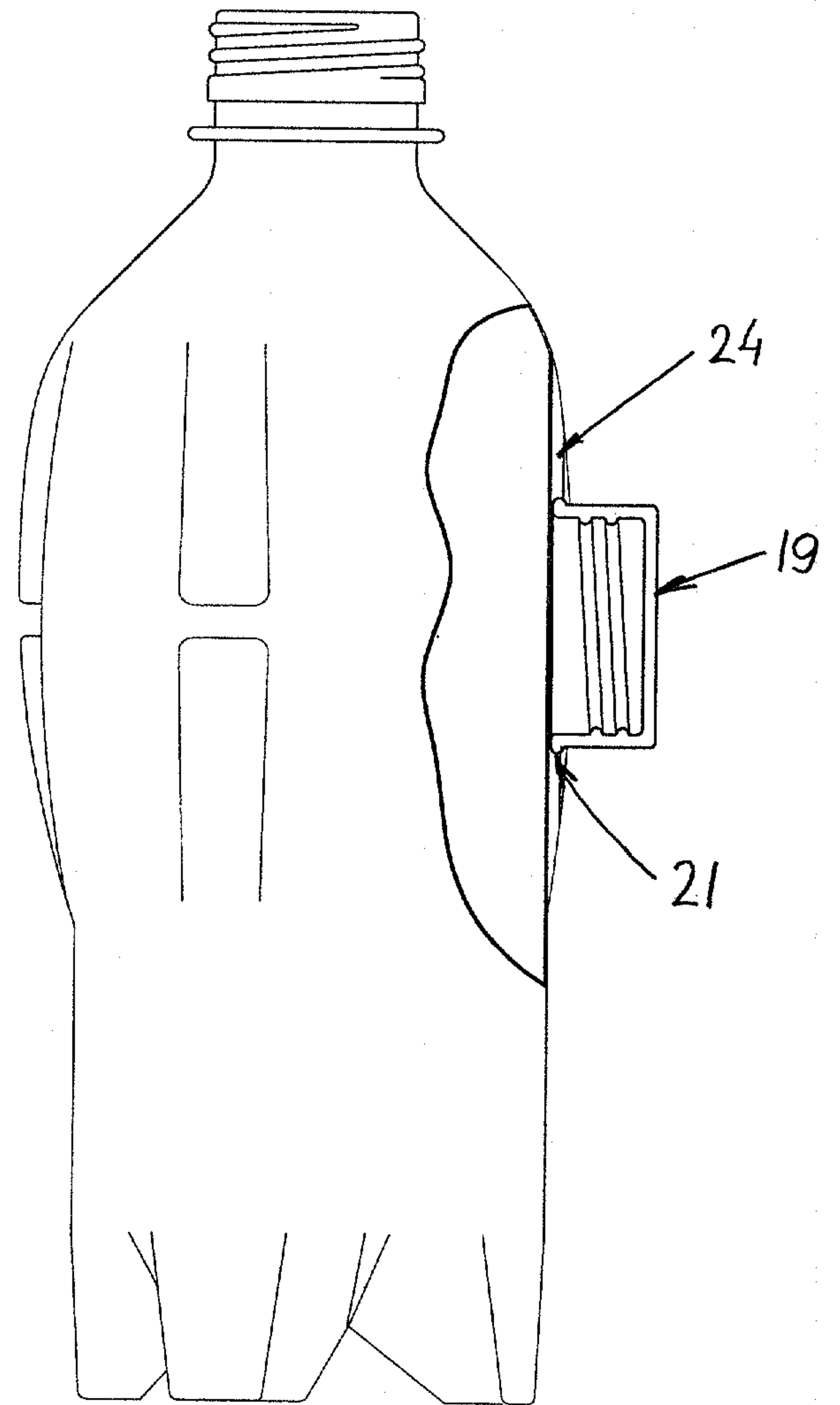

Fig. 4.c. (H-H)

