

(19)



Europäisches Patentamt
European Patent Office
Office européen des brevets



(11)

EP 0 896 094 B1

(12)

EUROPEAN PATENT SPECIFICATION

(45) Date of publication and mention
of the grant of the patent:
21.05.2003 Bulletin 2003/21

(51) Int Cl.7: **E01C 23/06**

(21) Application number: **98111831.8**

(22) Date of filing: **26.06.1998**

(54) **Machine in a road paving recycling train for cold recycling of road paving**

Maschine in einem Fertigungszug für Kaltrecycling von Strassenbelag

Machine pour train de recyclage à froid de revêtement routier

(84) Designated Contracting States:
CH DE ES FR GB LI

(74) Representative: **D'Agostini, Giovanni, Dr.**
D'AGOSTINI ORGANIZZAZIONE
Via G. Giusti 17
33100 Udine (IT)

(30) Priority: **06.08.1997 IT UD970143**

(43) Date of publication of application:
10.02.1999 Bulletin 1999/06

(56) References cited:
EP-A- 0 282 381
EP-A- 0 497 755
US-A- 4 195 946
US-A- 4 317 642

EP-A- 0 378 973
DE-A- 2 847 924
US-A- 4 290 820

(73) Proprietor: **MARINI S.p.A.**
48011 Alfonsine (Ravenna) (IT)

(72) Inventor: **Cipriani, Antonio**
48011 Alfonsine (RA) (IT)

EP 0 896 094 B1

Note: Within nine months from the publication of the mention of the grant of the European patent, any person may give notice to the European Patent Office of opposition to the European patent granted. Notice of opposition shall be filed in a written reasoned statement. It shall not be deemed to have been filed until the opposition fee has been paid. (Art. 99(1) European Patent Convention).

Description

[0001] The present patent has for object a machine for road paving cold recycling train.

[0002] The train comprising said machine is also object of the invention.

[0003] The invention finds particular even if not exclusive application as a self-propelled or towed equipment for operating "in situ" in the road paving and repaving utilising also the recyclable material obtained by the milling (scarification) of the already existing road paving (art commonly also known as "stabilisation").

State of the art for "in situ" operations.

[0004] In the present state of the art self-propelled road repaving systems operating "in situ" are known.

[0005] The art of road repaving directly on road, provides the mixing and preparation of components on the same road after having carried out the milling of the road paving by means of a self-propelled milling machine known as scarifier machine, which mills the material by means of an upstream milling machine discharging it in the shape of a continuous heap, that is loose material string, with possible addition before or after the milling, of new grit by a grit spreader, for the correction of the new granulometric curves.

[0006] The road mixing arts related to the previous phases, are substantially three:

"Blade mixing" (using a motograder).

[0007] On a material left as loose material string by the scarifier machine and evenly spread by a motograder (grader machine), the following operations are carried out:

- partial application of the bituminous binder, because the application occurs in subsequent phases, by a pressure distributor;
- pre-mixing: the motograder mixes partially binders and aggregate (milled material to be recycled and new grit) trying to leave the less amount of aggregates uncovered by the binder;
- mixing: the pre-mixed material is pushed forwards and backwards along the road axis, always in shape of a loose material string, up to when the aggregates covering by the binders is the most homogeneous possible.

[0008] This solution provides considerable operating limits and high working costs.

[0009] In particular it can be noticed that the blade (motograder), may be used only when the amount of material to be mixed on the road is relatively small, and furthermore, many machines are necessary for the work and an even mixing is impossible to be obtained, finally the operating times are extremely long and the use of

concrete creates the drawback of raising a considerable amount of concrete dust.

[0010] Mechanical mixing by self-propelled machine.

[0011] Also in this solution a form of ground pre-mixing is provided for then ending the operation by a mechanical mixer.

[0012] Different types of mechanical mixers exist.

[0013] The most known type is known as "Pulvimixer", which provides to add the binder on ground before the mixing while the machine moves forwards.

[0014] The mechanical mixing is carried out by rotational agitation of aggregate and binder which occurs by means of one or more horizontal shafts provided with vanes.

[0015] If with this system the disadvantages of the previous blade method are eliminated and a better mixing is obtained, a perfectly homogenous mix is not obtained because of the difficulty of maintaining constant the ratio of the binding material in the loose material string before the mixing.

[0016] In case of a stabilisation with concrete also the problem of dust raising during the ground spreading process exists.

[0017] Train continuous automatic mixing and collection.

[0018] In this art equipment known as "Wood train" which is provided with many self-propelled and towed machines or equipment which works train-like is used.

[0019] The "Wood train" is substantially made up of:

- an inert material distributor (grit spreader)
- a scarifier (road paving milling machine);
- an heap shaper-measurer for forming a continuous and constant in loose material string section;
- a loose material string collecting machine or loading machine (at which the present invention is substantially aimed);
- a continuous mixing machine with rotary drum associated with a binding material spreader;
- a separate tank truck for the binding material, endowed with conveying means for making the necessary binding material flow into the machine through said spreader.

[0020] By the "Wood" train method, the work is started by the scarifier machine which mills the road paving at a certain depth transforming the road paving in granular form discharging it as string (loose material string) downstream where the heap shaper-measurer adjusts it.

[0021] In case of need for the granulometric curve correction, the corrective grit is spread by a grit-spreader upstream of the scarifier machine, directly on the road paving which must be milled, so that an even mixing of the virgin material with the one to be recycled is obtained, by means of the action of the same millers.

[0022] The train of machines which mainly concern the mixing, therefore downstream of the scarifier which

generally operates separately, consequently provides at the top, a movable loader which conveys the material previously prepared in strings to a proportioning hopper, from which by a suitable volumetric dosage, it is discharged on a mixing towed machine.

[0023] The mixing towed machine, mixes the materials inserting the hot or cold bituminous binder in a mixer, by a pump connected to the aggregates feeding system so to add the binder necessary for the mixing picking it up from the tank truck also located on the train or placed by its side.

[0024] The mixer is made up of a cylinder having a rotor with buckets supported by hydraulic jacks connected to the machine frame.

[0025] One or more direct flame burners for the eventual binder heating are provided.

[0026] The mixed material is discharged as a string (loose material string), from the cylinder rear mouth.

[0027] The material laying is carried out by vibratory finishing machine fed by suitable loader, with following pressing or rolling, carried out by gummed rolls and vibratory tandem rollers.

[0028] The tank truck has the function of constantly feeding the binder (if it is a bituminous one) or water (when concrete is used) to the mixer and it must therefore move in step with the other machines group.

[0029] In this case it can be noticed that the train advances being fed by the string (loose material string) of material which it finds in front of it and leaves behind a string (loose material string) of mixed material ready to be used for the road repaving.

[0030] Of course the same train may carry out stabilisations with concrete or other binders (generally cold) such as for example bituminous conglomerates in solution with solvents or in water emulsion.

[0031] In the first case the concrete is spread with the corrective material such as for example new grit (not necessarily simultaneously) before the milling end the mixer will receive water from the tank truck in the ratio required.

[0032] By this "Wood" train self-propelled solution, the drawbacks as in the two first solutions are obviated, but when stabilisations with the use of concrete must be carried out it can be noticed that:

- making a vehicle which transports and doses concrete move in step with the machines train becomes difficult;
- conveying the concrete from a vehicle to the other one is as much difficult;
- the addition of another vehicle (for concrete feeding) makes even more complex and longer the equipment which is already made up of a large series of means.
- proportioning and making constant the amount of binding material results difficult, thus involving as a consequence the same drawbacks of the previous solutions.

[0033] In the "Wood" train there are anyway many drawbacks, and in particular equipment length, preparation of a poorly homogeneous mix and anyway the new stratification on the roadbed has an adhesion level not always acceptable, so that there is often a separation danger, particularly if water infiltrations occur and this also when associated with changes in temperature and in particular in the presence of ice and thaw.

[0034] In such a case some separation spots are formed, which with the vehicles passage, become always bigger and make very dangerous the vehicles running particularly at high speeds.

[0035] With the IT-83469 A/88 the same Marini proposed a solution for a train which may solve some of the above mentioned problems.

[0036] In particular the IT-83469 A/88 claims an equipment for the continuous mixing and producing of different compositions conglomerates, in which it is provided:

- a base mixing unit, associable with:
- a detachable unit for the solid binder addition in powder interchangeable with
- a detachable alternative unit for the liquid or semi-liquid binder addition.
- or vice versa.

[0037] In such a way it is possible by using the same mixing unit, to prepare stabilised conglomerates both with concrete and with bitumen, by changing the binder feeding unit from the whole mixing structure.

[0038] In said solution the mixing unit comprises a mixing group (equipped/able with a device for spraying water or volumetrically dosed bituminous binders), of the "Trough" type with a couple of horizontal and slightly tilted shafts, placed longitudinally parallel to each other provided with opposite rotating mixing vanes.

[0039] In such a way it is possible to compact at the maximum the mixing unit dimensions being able to easily arrange the binder addition unit above the mixing group.

[0040] The result will be a train having a restrained width.

Background Art

[0041] The "Wood" train and this latter solution are mainly close to the object of the present invention.

[0042] Both the "Wood" train and the self-propelled train conceived with the IT-83469 though have the drawback of having a limited operating capacity particularly for what concerns the binding effect of the new road paving coating.

[0043] This is particularly due to the fact that the material treatment is carried out along the road.

[0044] For solving this drawback it would be necessary adding an intermediate machine between the col-

lecting machine and the mixing machine which provides for a perfect cleaning of the roadbed before the spraying of the binding material and the laying of the mixed material carried out by the mixing machine, but this addition of an intermediate cleaning machine, besides making the train longer, makes the transferring of the material collected by the collecting machine to the following mixing machine difficult.

[0045] The problem is therefore of difficult solution.

[0046] US4290820A (SWISHER JR GEORGE W ET AL), discloses a front-end apparatus for collecting particulate material on a roadway surface comprising a frame assembly, drivingly supported on the roadway, a windrow formation assembly supported at the forward end of the frame assembly for brushing particulate material into a windrow. and a feeder assembly disposed to engage the windrowed material up and onto a roadway scraper blade supported at the forward end of the frame assembly. An elevator assembly is disposed to receive the particulate material from the feeder assembly and elevate the material to a rear overhead discharge position. A residual material cleaning assembly is supported beneath the frame assembly and rearward to the feeder assembly for cleaning up residual material not collected by the feeder assembly, the residual material cleaning assembly directing the residual material to the elevator assembly so that the residual material is elevated to the rear overhead discharge position.

[0047] EP-A-0378973 (Todini Costruzioni Generali), discloses a train with two-connected machines having:

- gathering means for gathering the material from the road (2) to be mixed;
- means (4) for transferring the collected material (2) into an accumulation hopper (8) including weighting means (9);
- means (6) for the cleaning and subjecting to suction the roadbed (7) on which the new layer is to be spread out;
- means (10) for transferring said material from the hopper (8) to a screen (11);
- a device (12) for crushing the material rejected by said screen (11);
- at least one reservoir (5, 14) for the binding material;
- a mixer (13) and a device (16) for spreading out (the Nerw layer.

[0048] In this solution the means for the cleaning and subjecting to suction the roadbed is a single fixed one device, so not adjustable in width.

[0049] Purpose of the present invention is to better perform this apparatus and is that of obviating the above mentioned drawbacks and in particular of realizing a compact and operationally effective train for supplying a more reliable and lasting road stratification.

Essence of the invention

[0050] The present invention solves the mentioned problems as claimed by means of a machine movable on wheels or tracks, for a road paving cold recycling train, for the continuous collection of loose material in a loose material string along the road carpet restoration path, of the type frontally involving two arms with means for the collection of the loose material in front of its path and conveying means on a downstream mixing machine, wherein between the front wheels or tracks and rear wheels or tracks, some suction means (SA) are installed intended to suck all that granulated material and dust which the front collecting means were not able to collect from the underlying paving, characterized in that said suction means comprise a transversal extended suction mouth placed centrally and two extended suction mouths placed laterally movable and adjustable in their distance and extending for such a width to cover a part of the central one and project at least beyond the central one.

[0051] Thus the advantage of coating variably all the concerned roadway is obtained.

[0052] As much advantageously said laterally placed suction mouths are retractable within said central suction mouth width.

[0053] Thus the advantage of operating also in a minimum roadway is obtained.

[0054] As much advantageously said-centrally placed suction mouth is the front one while said two laterally placed suction mouths, are placed behind the first one respect to the advancement direction.

[0055] Thus the advantage of a coating by following suction of the edges exceeding the central suction mouth is obtained with a decidedly better roadbed cleaning result.

[0056] As much advantageously said -laterally placed suction mouths are aligned.

[0057] Thus the system is more simplified and a better system compactness and cleaning effectiveness is obtained.

[0058] As much advantageously said -suction mouths are connected to suction means for piping by flexible ducts.

[0059] Thus the advantage of freely moving the suction mouths respect to the machine frame is obtained, making the following of the roadbed more effective.

[0060] As much advantageously said -flexible ducts are directed backwards.

[0061] Thus the suction ducts are structurally placed more functionally.

[0062] As much advantageously said-suction mouths are connected to a suction group preceded by a decantation tank.

[0063] Thus the advantage of stocking the collected material and eventually recycling it, avoiding outside pollution, is obtained.

[0064] As much advantageously said-suction mouths

are suspended by articulated arms tilted backwards respect to the advancement direction.

[0065] Thus a better suction structure functionality is obtained favouring the suction mouth fitting to the road-bed.

[0066] As much advantageously at least one of said articulated arms is parallelogram-like shaped.

[0067] Thus the advantage of maintaining the suction mouths always vertically directed independently of their position is obtained.

[0068] As much advantageously said-suction mouths involve downstream respect to the advancement direction some paving resting small wheels behind the respective suction mouths.

[0069] Thus the suction operating effectiveness is improved, by making the small wheels roll on a clean surface.

[0070] As much advantageously said-decantation tank and suction means are substantially placed in the front, with the collecting means in the back and above a respective conveyor belt which from beneath and behind the front collecting means, raises tilted backwards and protrudes backwards with a jut for the downstream discharge.

[0071] Thus the machine which is in such a way effectively structured is effectively compacted.

[0072] As much advantageously the rear machine has a screening and further grinding system (B) to which with an analogous system the mixing machine is fastened according to the previous claim.

[0073] Thus a train structured for a more effective and homogeneous treatment of the recycled material which sometimes may be also in large scarified pieces needing a further screening and grinding is obtained.

[0074] As much advantageously said-collecting machine comprises a container of liquid to be added to mixing means of the rear mixing machine.

[0075] Thus the advantage of better compacting the train is obtained.

[0076] As much advantageously said tank for liquid material is equipped with heating means for the contained liquid.

[0077] This also allows to operate with hot liquid.

[0078] As much advantageously the machine is self-propelled and it is endowed with at least one front control position and with a rear bascule hitch for the hitching of a trailer which makes up the rear mixing or intermediate screening and grinding machine.

[0079] Thus a functionally articulated train suitable to any type of working is obtained.

[0080] The train realized comprises at least one towed mixing machine which utilises:

- a mixing basic unit involving a mixing group, associable with:
- a detachable unit for the solid binder powdery addition interchangeable with

- a detachable alternative unit for the liquid or semi-liquid binder addition,
- or vice versa.

5 **[0081]** Thus the train is made operationally universal for operating both with a solid and with a liquid binder.

[0082] As much advantageously the mixing machine has a mixing group of the type having a couple of substantially horizontal shafts, parallel to each other and rotating in opposition equipped with radial vanes.

10 **[0083]** Thus a more effective materials mixing is obtained.

[0084] As much advantageously between said front loose material string collecting machine and said mixing machine, is installed, as said, an intermediate machine for working again the material to be recycled, comprising means for the screening of the material to be recycled, means for the crushing of the screen scrapped material and means for conveying all the material, both screened and crushed to said rear mixing machine. Thus forming complete treatment train also for the rough material.

20 **[0085]** As much advantageously said -mixing machine upstream comprises a compensation hopper:

- 25 - provided with means for detecting the amount of material discharged in it connected with the equipment operativeness for a control of the respective continuous flow operating uniformity of the material;
- and comprising a generator system (6) for the feeding of the equipment operating motor means, and
- 30 - respective electric board placed downstream.

[0086] Thus a more effective mixing machine is obtained.

35 **[0087]** As much advantageously in said mixing machine, said detachable unit for the solid binder powdery addition comprises:

- a tank with lateral feet which protrude for being fixed on a frame which supports said mixing group;
- filtering means for discharging the air inlet inside of the tank during the loading of the powdery material;
- lower longitudinal scroll means for picking up the powdery material in said tank, associated with conveying means to a buffer hopper placed at the head, whose lower mouth comprises volumetric dosage means which convey the material on a following scroll conveyor to said mixing group.

50 **[0088]** Thus the train is operationally better functional.

[0089] As much advantageously said-detachable unit for the liquid binder addition comprises:

- a tank with lateral feet which protrude for being fixed on a frame which supports said mixing group;
- means for the heating by pipe coil placed inside of said tank connected with
- heating boiler means placed on the tank head

equipped with fuel burner means vertically placed from the top downwards, for heating the heat exchanger liquid in said pipe.

[0090] Thus a universal train is obtained.

[0091] These and other advantages will appear from the following detailed description of preferred forms of embodiment with the aid of the enclosed drawings whose execution details are not to be considered as limitative but only as examples.

[0092] Figure 1 shows a schematic elevation side view of the machine for collecting and mixing the loose material string (loose material milled or placed by the preceding machine along the road in a continuous heap similar to a string) on the road as a means movable on wheels, towed or self-propelled, according to the present invention.

[0093] Figure 2 shows a working train view, utilising a tracked collecting and mixing machine according to the invention as a variation to Fig. 1 and with advancement direction opposite respect to the machine of Fig. 1.

[0094] Figure 3 shows a view as in Fig. 1 in which the mixing equipment is seen from the top.

[0095] Figure 4 shows a train as in Fig. 2 equipped with auxiliary tank for proportioning the bituminous emulsion together with the one installed on the mixing means.

[0096] Fig. 5 shows a working train with an intermediate trailer for the screening of the collected material and for the crushing of the crumbs too large to be set in cycle again on the following mixing trailer.

[0097] Figures 6 and 7 show two interchangeable disassembled units alternatively mountable on the mixing machine according to the need of adding concrete binder in powdery solid form or of adding bituminous binder in liquid form.

[0098] Figure 8 shows an operating scheme of the bituminous liquid binder heating and feeding for the machine as in figures 3,4 utilising the feeding unit as in figure 7.

[0099] Figure 9 shows a section view of the mixing machine (C), behind the hopper 3.

[0100] Figures 10 and 11 show the embodiment of the mixer with two opposite shafts of the hopper 3 of the material mixing machine, better illustrated in the two versions in the following figures 12 and 13.

[0101] The Figures 12 and 13 show the mixing machine in the two forms both having also cold solid binder and liquid binder (for example of the type with chemical reaction with accelerating products).

Loose material string collecting main machine (A)

[0102] Referring to the figures it should be noticed that the train comprises at least the loose material string collecting machine (A), which is directly followed by the mixing trailer (C) Figs. 2, 4 or by the screening and grinding one (Fig. 5).

[0103] It can be noticed that the loose material string collecting machine (A) comprises on the front some conveying jaws (23) for collecting loose material string (milled material to be recycled) with overhanging drive cabin of known art (23').

[0104] From the picking up head which has a jaws-like shape (23), also by means of some brushes (231, 232, 233), the material is transported by a conveyor belt (24) downstream for being discharged on the following trailer (B or C).

[0105] There is a first drum-like rotating brush 231 which is placed tilted and extends beyond the edge of the scarification line, for brushing the material within the scarification line generally being some centimetres lower.

[0106] Subsequently there are two rotating cup-like brushes with vertical axis (232, 233) which convey the material towards the centre where the loose material string to be picked up is placed.

[0107] Thus the material which is spread on the side of the loose material string is joined with the same loose material string before being picked up.

[0108] Two opposite adjustable tilted deflectors (234) have the function of conveying and better join the loose material string scarified by the front milling machine or laid by front machines, before the collection by the collection mouth 235 of known art. A tank (25) able to contain water absolutely necessary when the stabilisation with concrete system is used, but also useful for a "cut back" or for bituminous emulsion anyway contained in the tank of the mixing trailer "C" is also provided.

[0109] It is obviously also possible stocking in said self-propelled first machine tank an additional bituminous binder, being possible for this last case to provide some heat exchange oleothermal pipe coils (25') which would allow its heating if needed.

[0110] Finally, it is understood that adding a water tank to this last tank, it would be possible, by using the same train, and equipping the mixing means with the addition unit involving the concrete tank, to carry out alternative stabilisations both with concrete and with bitumen, without changing anything in the respective working train structure.

[0111] The present invention is substantially aimed at this first machine because between the front wheels and tracks group and the rear wheels and track group, the suction group (SA) is applied.

[0112] The suction group (SA) by three suction mouths, of which a central one 91 and two lateral ones 91' adjustable towards the centre or outwards which allow to cover the whole roadway, will determine the complete suction of granules and dust not collected by the front collecting system (23).

[0113] The sucked material is conveyed by flexible pipes to a decantation tank or collector 92 upstream of an exhaustor 93 which will discharge the sucked air from the bottom (91,91') outside.

[0114] Thus the great advantage that the road train to

be coated will be perfectly clean and with no dust, improving the downstream spraying effectiveness of the sticking liquid product provided in the final part (8) of the following mixing machine (C).

Mixing machine (C)

[0115] To the loading and cleaning machine (A) with the above mentioned characteristics, at least a second mixing machine (C) is joined in the rear and towed, which has an alternative interchangeable mixing unit for adding solid (concrete) or liquid binder material (7, 7a Figs. 6 and 7).

[0116] This mixing machine has practically the function of proportioning, stocking and mixing.

[0117] The machine has substantially the function of:

[0118] The mixing machine (C) comprises substantially a trailer structure (1), on whose frame is frontally mounted an hopper for loading the agglomerate material (T/20) coming from the front collecting self-propelled machine (A).

[0119] This hopper (T) is wide enough for acting as plenum chamber for the charge material so to compensate the flow variations being provided at its base with an adjustable proportioning device of known art, and having in it some minimum and maximum level indicators in order to allow the control of the overload and sub-load conditions.

[0120] The hopper (T) is also provided with vibratory means with adjustable vibratory characteristics with intermittent working for easing the materials downflow. At the hopper base, a conveyor belt (2.1) with variable speed electric working, conveys the weight dosed material from the hopper (2) into the mixing group placed between the side members of the trailer frame (3).

[0121] The mixing group (3) is of the type with two longitudinally placed shafts, parallel to each other (3.1-3.2) with reversible adjustable vanes (3.5), with upper entry system upstream (3.3) and lower discharge downstream (3.4) on a conveyor belt (4) which discharges the mixed conglomerate behind the means for the following laying and pressing for the road carpet betterment.

[0122] On the mixing group rear (3) a generator set (6) for feeding power to the motors and to the eventual heating means is placed. Close to it is also placed in an easy accessible position the electric equipment cabin (5).

[0123] The interchangeable binder feeding units, respectively comprise a unit for supplying powder concrete (7) and a unit for liquid bituminous substances in cold emulsion or anyway at a low temperature (7a).

[0124] Both the concrete feeding unit (7) and the bituminous binder feeding one (7a) provide a tank which extends over the mixer (3), with feet for the resting and fixing to the trailer (1) side members astride of the mixing group and both have on their rear the operating and control means.

[0125] More particularly the solid binding substances

addition unit (7) further comprises a filter system for discharging the pressurised air which is inlet in its inside during the concrete loading, allowing the air discharge in the atmosphere and simultaneously avoiding the concrete outlet. In the rear a buffer hopper (13) is also provided to which the conveying system leads made up of: extraction scrolls (10), by collecting scroll (11) and lifting scroll (12), which provides to pour the concrete into the buffer hopper (13) beneath which an adjustable proportioning delivering system of the volumetric type of known art which discharges the concrete in a conveying scroll to the mixer (15) is provided.

[0126] The liquid binding substances addition unit (7a), provides on the rear a boiler (16) with vertical burner from the top downwards (17) which heats a diathermic oil pipe which extends as a coil (18) within the respective tank (7a) by pump circulation (19 Fig. 8).

[0127] The liquid binder control system is carried out according to the scheme as in Fig. 8 in which the use of a feeding pump to the mixer (20) with liter-counter (21) may be seen, while the spraying ramp (22) is inserted within the mixing group and above the mixing shafts couple (3.1-3.2).

[0128] It is understood that with this arrangement, when only the water tank (25) is used upstream of the self-propelled means (A), it will be necessary only to change the tank (7) with the tank (7a) for alternatively operating with powdery binders (concrete) or with liquid binders (bituminous ones).

[0129] In the mentioned examples self-propelled and towed solutions were shown.

[0130] Similarly a low temperature bituminous emulsion solution was shown, but nothing prevents from using fluxed bitumen solutions.

[0131] It will be noticed that the use of a mixer with a couple of opposite rotating parallel shafts (3.1-3.2) is of fundamental importance in the specific sector (this mixing group being previously known and used, but for other purposes, such as for example for the mixing in fixed equipment).

[0132] Said mixers with a shafts couple (3) never found a practical and suitable application in the sector of the train continuous mixing machines, because up to now the use of the drum mixer was considered more useful and functional.

[0133] The use of this mixer combined with said interchangeable tanks (7, 7a). adds a better inventive character to the solution proposed embodying an innovative combination in its field, and besides allowing to reach the provided aims of maximum effectiveness and operativeness, it allows to strongly compact the equipment. In fact the use of this cylindrical mixer as adopted in the self-propelled solutions would not make such a compaction possible, being notoriously obligatory containing the operating machine within the allowed dimensions for transportation.

[0134] If to what stated above the universalisation of the equipment which thus structured becomes usable

indifferently for the stabilisation both with concrete and with bitumen is added, the innovative importance is well understood, with the further advantage that the mixing qualitative result maintains its optimal characteristics with maximum homogeneity.

[0135] In the train preferred solution, the head compensation hopper (T/20) acting as a plenum chamber, makes furthermore possible also operating on uneven strings and this independently of the respective operating speed.

[0136] Of course in the rear, before the delivery of the mixed material by the deliverer 4, the device for spraying the binder on the roadbed 8 is provided, which wetting the clean surface, thanks to the exhauster carefully placed according to the present invention in the machine (A) makes possible the better sticking of the material by the following passing of the train final machine (not shown) which will lay, stretch and compact the material at its thickness (vibratory finishing machine).

[0137] As it may be seen in the figures and in particular in Fig. 1, the suction system SA provides the suction mouths (91, 91') being articulated by articulated arms (94) preferably parallelogram-like shaped for keeping the mouths horizontal (94'), some rear small wheels for maintaining the distance constant respect to the paving (95, 95') being provided, being the suction ducts of the flexible type for an easy fitting to the respective movement.

[0138] The suction discharges advantageously upwards (93') depolluted air, thanks to the decanter 92.

[0139] This machine, is equipped with variable revolutions volumetric pump for the water dosage, or of the bituminous binder, by a delivery mass meter.

[0140] The pump delivery is controlled by the mass meter in function of the momentary delivery measured for the inert materials.

[0141] It also has the water spraying ramp (in case of concrete binder) or of the bituminous binder.

[0142] Water spraying ramp along the mixer for the cleaning at the end of the cold conglomerate production.

[0143] The ground spraying ramp is located on the rear (8), for spraying the layer which sticks on the previously perfectly cleaned roadbed according to the invention by the front machine device (SA).

[0144] The ramp comprises means for the sprayed material heating.

Screening and grinding or granulating intermediate machine (B)

[0145] In figure 5 an intermediate trailer (B) between the machine (A) and the machine (C) is provided, with the function of collecting the material poured by the front collecting machine (A) by means of the conveyor (24) for screening it in the hopper (26) and deviating the too large milled material to the crusher or grinder (27) which pours the crushed material. that is granulated, on the underlying conveyor (28) of the previously screened

material for making it enter the following mixing trailer (C) by means of a conveyor belt (30).

At the train head

[0146] An eventual head milling machine (not shown) will provide for the old asphalt thickness milling arranging it in a loose material string for being collected by the machine (A).

At the train tail

[0147] At the train tail, as it was said, the so called vibratory finishing machine (not shown) will be working.

Claims

1. Machine movable on wheels or tracks, for road paving cold recycling train, for the collection in continuous of loose material in a loose material string along a road carpet (A) restoration path, of the type frontally comprising two arms with means for collecting the loose material (23) and conveying means (24) on a downstream mixing machine (C), wherein, between front wheels or front tracks and rear wheels or rear tracks of the machine, suction means (SA) are installed intended to suck all that granulate material and dust which the front collecting means (23) were not able to collect from the underlying paving, **characterized in that** said suction means (SA) comprise a transversal extended suction mouth placed centrally (91) and two extended suction mouths placed laterally (91') movable and adjustable in their distance and extending for such a width to cover a part of the central one (91) and project at least beyond the central one (91).
2. Machine according to claim 1., **characterized in that** said laterally placed suction mouths (91') are retractable within said central suction mouth width (93).
3. Machine according to previous claim 2, **characterized in that** said centrally placed suction mouth (91) is the front one while said two laterally placed suction mouths (91'), are placed behind the first one respect to the advancement direction.
4. Machine according to claims 2 or 3, **characterized in that** said laterally placed suction mouths (91') are aligned.
5. Machine according to any of the previous claims, **characterized in that** said suction mouths (91, 91') are connected to suction means for piping (92-93) by flexible ducts (96).

6. Machine according to claim 5, **characterized in that** said flexible ducts (96) are directed backwards.
7. Machine according to claims 2 or 3, **characterized in that** said suction mouths (91, 91') are connected to a suction group (93) preceded by a decantation tank (92).
8. Machine according to any of the previous claims, **characterized in that** said suction mouths (91, 91') are suspended by articulated arms (94, 94') tilted backwards respect to the advancement direction.
9. Machine according to claim 8, **characterized in that** at least one of said articulated arms is parallel-ogram-like shaped (94').
10. Machine according to any of the previous claims, **characterized in that** said suction mouths (91, 91') involve downstream respect to the advancement direction some paving resting small wheels (95) placed behind the respective suction mouths (91, 91').
11. Machine according to any of claims 7-10, **characterized in that** said decantation tank (92) and suction means (93) are substantially placed in the front, with the collecting means in the back (23-23') and above a respective conveyor belt (24) which from beneath and behind the front collecting means (23), raises tilted backwards and protrudes backwards with a jut for downstream discharge (24').
12. Machine according to previous claim 11, **characterized in that** said conveyor belt (24), discharges downstream (24') on a hopper (T) into an operating machine towed from the back (B-C) in a hopper system (20) with underlying conveyor (20').
13. Machine according to any of the previous claims, **characterized in that** it additionally comprises a tank for the liquid (25) to be added to mixing means (3) of the rear mixing machine (C).
14. Machine according to any of the previous claims, **characterized in that** said tank for the liquid (25) is equipped with means for the contained liquid heating (25').
15. Machine according to any of the previous claim, **characterized in that** it is self-propelled and it is endowed with at least a front control position (23') and a rear bascule hitch for the hitching of a trailer as mixing machine (C or intermediate screening and grinding machine (B).
16. Machine according to any of the previous claims, **characterized in that** it comprises on the front two conveying jaws (23) for collecting loose material string as material to be recycled with overhanging drive cabin (23').
17. Machine according to previous claim 16, **characterized in that** said jaws (23) have a first drum-like rotating brush (231) which is placed tilted and extends beyond the respective jaw.
18. Machine according to claims 16 or 17, **characterized in that** said jaws comprise at least two rotating cup-like shaped vertical brushes (232, 233) which convey the material towards the centre.
19. Machine according to claim 18, **characterized in that** between the said jaws and after said two rotating cup-like shaped vertical brushes (232,233) two opposite adjustable tilted deflectors (234) are provided with the function of conveying and better join the loose material string towards the centre concerning the collecting mouth (235).
20. Train for the continuous mixing and producing of different compositions conglomerates particularly for road paving or repaving comprising an upstream machine for collecting the loose material string according to any of previous claims, the train further comprising at least one mixing towed machine (C) with:
- a base mixing unit involving a mixing group (3), associable with:
 - a detachable unit for solid binder addition in powder (7) interchangeable with
 - a detachable alternative unit for liquid or semi-liquid binder addition (7a),
 - or vice versa.
21. Train involving a mixing machine according to previous claim 20, **characterized in that** the same has a mixing group of the type with a couple of substantially horizontal shafts, parallel to each other and rotating in opposition equipped with radial vanes (3.1-3.2).
22. Train according to any of claims 20-21, **characterized in that** it provides between said loose material string collecting machine and said mixing machine (C), an intermediate machine for working again the material to be recycled, comprising means for the screening of the material to be recycled (26), means for the crushing of the screen scrapped material (27) and means for conveying all the material, both screened and crushed (30) to said rear mixing machine (C).
23. Train according to any of claims 20-22, **character-**

ized in that said mixing machine (C) upstream comprises a compensation hopper (20):

- provided with means for detecting the amount of material discharged in it connected with the equipment operativeness for a control of the respective continuous flow operating uniformity of the material; 5
- and in comprising a generator system (6) for the feeding of the equipment operating motor means, and respective electric board placed downstream. 10

24. Train according to any of claims 20-23, **characterized in that** in said mixing machine (C), said detachable unit for the solid binder powdery addition comprises:

- a tank (7) with lateral feet which protrude for being fixed on a frame (1) which supports said mixing group; 20
- filtering means for discharging air inlet inside of the tank during the loading of the powdery material (9);
- lower longitudinal scroll means (10) for picking up the powdery material in said tank (7), associated with conveying means (11, 12) to a buffer hopper placed at head (13), whose lower mouth comprises volumetric dosage means (14) which convey the material on a following scroll conveyor (15) to said mixing group (3). 25 30

25. Train according to any of claims 20-24, **characterized in that** said detachable unit for the liquid binder addition comprises: 35

- a further tank (7) with lateral feet which protrude for being fixed on a frame (1) which supports said mixing group (3);
- means for the heating by pipe coil placed inside a tank (18) connected with 40
- heating boiler means placed on tank head (16) equipped with fuel burner means vertically placed from the top downwards (17), for heating the heat exchanger liquid in said pipe (18). 45

Patentansprüche

1. Auf Rädern oder Schienen bewegliche Maschine, für einen Fertigungszug zum Kaltrecycling von Straßenbelag, zur kontinuierlichen Sammlung von losem Material in einer Reihe von losem Material entlang einer Straßenbelag- (A) Ausbesserungsfläche, vom Typ frontal mit zwei Armen mit Mitteln, um das lose Material (23) zu sammeln, und Transportmittel (24) auf einer nachgeschalteten Mischmaschine (C), wobei, zwischen Vorderrädern oder

vorderen Schienen und Hinterrädern oder hinteren Schienen der Maschine, Saugmittel (SA) installiert sind, um das ganze Granulatmaterial und den Staub aufzusaugen, den die vorderen Sammelmittel (23) nicht von dem darunterliegenden Straßenbelag hatten aufnehmen können,

gekennzeichnet dadurch, dass besagte Saugmittel (SA) einen querlaufende erweiterte Saugöffnung umfassen, die zentral gelegen (91) ist, sowie zwei seitlich gelegene erweiterte Saugmünder (91'), die beweglich und abstandsverstellbar sind und eine derartige Breite aufweisen, dass sie einen Teil der zentralen (91) überdecken und mindestens über die zentrale (91) hinaus vorragen.

2. Maschine nach Anspruch 1., **gekennzeichnet dadurch, dass** besagte seitlich platzierten Saugmünder (91') in besagte Breite der zentralen Saugöffnung (93) einziehbar sind.

3. Maschine nach dem vorherigen Anspruch 2, **gekennzeichnet dadurch, dass** besagte zentral platzierte Saugöffnung (91) die vordere ist, während die besagten seitlich platzierten Saugmünder (91') hinter der ersten in bezug auf die Vorrückrichtung gelegen sind.

4. Maschine nach Anspruch 2 oder 3, **gekennzeichnet dadurch, dass** besagte seitlich platzierten Saugmünder (91') in Linie sind.

5. Maschine nach einem beliebigen der vorherigen Patentansprüche, **gekennzeichnet dadurch, dass** besagte Saugmünder (91, 91') mit Saugmitteln zur Rohrleitung (92-93) durch flexible Rohrleitungen (96) verbunden sind.

6. Maschine nach Anspruch 5, **gekennzeichnet dadurch, dass** besagte flexiblen Rohrleitungen (96) rückwärts gerichtet sind.

7. Maschine nach Anspruch 2 oder 3, **gekennzeichnet dadurch, dass** besagte Saugmünder (91, 91') mit einer Sauggruppe (93) verbunden sind, der ein Dekantiertank (92) vorgeschaltet ist.

8. Maschine nach einem beliebigen der vorherigen Patentansprüche, **gekennzeichnet dadurch, dass** besagte Saugmünder (91, 91') an angelenkten Armen (94, 94') aufgehängt sind, rückwärts geneigt in bezug auf die Vorschubrichtung.

9. Maschine nach Anspruch 8, **gekennzeichnet dadurch, dass** mindestens einer der angelenkten Arme parallelgrammähnlich geformt (94') ist.

10. Maschine nach einem beliebigen der vorherigen Patentansprüche, **gekennzeichnet dadurch,**

dass besagte Saugmünder (91, 91') unterhalb der Vorschubrichtung einige auf der Straße aufliegende kleine Räder (95) umfassen, die hinter den betreffenden Saugmündern (91, 91') platziert sind.

11. Maschine nach einem beliebigen der Ansprüche 7-10, **gekennzeichnet dadurch, dass** besagter Dekantiertank (92) und Saugmittel (93) im wesentlichen an der Vorderseite platziert sind, mit der Sammeleinrichtung hinten (23-23') und oberhalb eines betreffenden Förderbandes (24), das sich von unterhalb und hinter der vorderen Sammeleinrichtung (23) erhebt, nach hinten geneigt und rückwärts vorstehend mit einem Vorsprung zur späteren Entladung (24').
12. Maschine gemäß dem vorherigen Anspruch 11, **gekennzeichnet dadurch, dass** besagtes Förderband (24) unterhalb (24') auf einem Trichter (T) in eine Arbeitsmaschine entlädt, die von hinten (B-C) in einem Trichtersystem (20) mit darunterliegendem Förderwerk (20') gezogen wird.
13. Maschine nach einem beliebigen der vorherigen Patentansprüche, **gekennzeichnet dadurch, dass** sie zusätzlich einen Tank für die Flüssigkeit (25) umfasst, die zu Mischmitteln (3) der rückwärtigen Mischmaschine (C) hinzugefügt wird.
14. Maschine nach einem beliebigen der vorherigen Patentansprüche, **gekennzeichnet dadurch, dass** besagter Tank für die Flüssigkeit (25) mit Mitteln zur Erhitzung (25') der enthaltenen Flüssigkeit ausgestattet ist.
15. Maschine nach einem beliebigen der vorherigen beanspruchen, **gekennzeichnet dadurch, dass** sie Eigenantrieb hat und mit mindestens einer vorderen Steuerposition (23') ausgestattet ist und einer rückwärtigen Kippaufhängung zum Anhängen eines Anhängers als Mischmaschine (C oder dazwischenliegende Sieb- und Schleifmaschine (B).
16. Maschine nach einem beliebigen der vorherigen Patentansprüche, **gekennzeichnet dadurch, dass** sie auf der Vorderseite zwei Förderbacken (23) umfasst, zum Sammeln von Reihen von losem Material als zu rezyklierendes Material mit überhängender Antriebskabine (23').
17. Maschine gemäß dem vorherigen Anspruch 16, **gekennzeichnet dadurch, dass** besagte Klemmbakken (23) eine erste trommelähnliche rotierende Bürste (231) aufweisen, die geneigt ist und sich jenseits der betreffenden Backe erstreckt.
18. Maschine nach Anspruch 16 oder 17, **gekennzeichnet dadurch, dass** besagte Klemmbakken

mindestens zwei rotierende kappenähnlich geformte senkrechte Bürsten (232, 233) umfassen, die das Material in die Mitte befördern.

- 5 19. Maschine nach Anspruch 18, **gekennzeichnet dadurch, dass** zwischen den besagten Klemmbakken und nach den besagten rotierenden kappenähnlich geformten senkrechte Bürsten (232,233) zwei gegenüberliegende verstellbare geneigte Ablenker (234) vorgesehen sind, mit der Funktion der Beförderung und des besseren Zusammenhalts des losen Materials auf die Mitte in Bezug auf die Sammelöffnung (235) zu.
- 10 20. Zug zum kontinuierlichen Mischen und Produzieren von Konglomeraten mit verschiedenen Zusammensetzungen, besonders zur Straßenasphaltierung oder -neuasphaltierung mit einer vorgeschalteten Maschine zum Sammeln der Reihe von losem Material nach einem der vorherigen Ansprüche, wobei der Zug des weiteren mindestens eine gezogene Mischmaschine (C) umfasst, mit:
- 15 - einer Basis-Mischeinheit mit einer Mischgruppe (3), verbindbar mit:
- 20 - einer abnehmbaren Einheit für die Zugabe eines festen Bindemittels als Pulver (7), austauschbar mit
- 25 - einer alternativen abnehmbaren Einheit für die Zugabe eines flüssigen oder halbflüssigen Bindemittels (7a),
- 30 - oder umgekehrt.
- 35 21. Zug mit einer Mischmaschine gemäß dem vorherigen Anspruch 20, **gekennzeichnet dadurch, dass** er eine Mischgruppe mit einem Paar im wesentlichen horizontale Wellen aufweist, parallele zueinander und rotierend in Opposition, ausgestattet mit radialen Flügeln (3.1-3.2).
- 40 22. Zug nach einem beliebigen der Ansprüche 20-21, **gekennzeichnet dadurch, dass** er zwischen besagter Maschine zum Sammeln der Reihe losen Materials und besagter Mischmaschine (C) eine Zwischenmaschine aufweist, um das zu rezyklierende Material erneut zu bearbeiten, mit Mittel zur Siebung des zu rezyklierenden Materials (26), Mittel zur Zerkleinerung des ausgesiebten Materials (27) und Mittel zum Befördern des gesamten Materials, sowohl des gesiebten als auch des zerkleinerten (30), zu besagter rückwärtigen Mischmaschine (C).
- 45 23. Zug nach einem beliebigen der Ansprüche 20-22, **gekennzeichnet dadurch, dass** besagte Mischmaschine (C) vorgeschaltet einen Ausgleichstrichter (20) umfasst:
- 50

- mit Mittel, um die Menge an Material ermitteln, die darin entladen worden ist, verbunden mit der Betriebsfähigkeit der Ausrüstung für eine Kontrolle der Uniformität des betreffenden kontinuierlichen Materialflusses im Betrieb;
- und mit einem Generatorsystem (6) zur Speisung des Betriebsmotors der Ausrüstung, und nachgeschalteter Schalttafel.

24. Zug nach einem beliebigen der Ansprüche 20-23, **gekennzeichnet dadurch, dass** in besagter Mischmaschine (C), besagte abnehmbare Einheit für die Zugabe von festem Bindemittel als Pulver folgendes umfasst:

- einen Tank (7) mit seitlichen Füßen, die vorstehen, um auf einem Rahmen (1) befestigt zu werden, der besagte Mischgruppe stützt;
- Filtriermittel für den Ablufteintritt in dem Tank während der Ladung des pulverförmigen Materials (9);
- untere Längsschnecken (10) zum Aufsammeln des pulverförmigen Materials in besagtem Tank (7), verbunden mit Transportmittel (11,12) zu einem Puffertrichter, der an der Spitze (13) liegt und dessen untere Öffnung volumetrische Dosiermittel (14) umfasst, die das Material auf einer folgenden Förderschnecke (15) zu besagter Mischgruppe (3) befördern.

25. Zug nach einem beliebigen der Ansprüche 20-24, **gekennzeichnet dadurch, dass** besagte abnehmbare Einheit für die Zugabe von flüssigem Bindemittel umfasst:

- einen weiteren Tank (7) mit seitlichen Füßen, die vorstehen, um auf einem Rahmen (1) befestigt zu werden, der besagte Mischgruppe (3) stützt;
- Mittel zur Erhitzung mittels einer Rohrschlange, die in einem Tank (18) liegt, verbunden mit
- Heizboiler auf dem Tankkopf (16), ausgestattet mit Brennstoffbrenner, der senkrecht von der Spitze nach unten (17) plaziert ist, zum Erwärmen der Wärmetauscherflüssigkeit in besagtem Rohr (18).

Revendications

1. Machine mobile sur roues ou rails, pour le train de recyclage à froid de revêtement routier, pour la récolte en continu de matériau non cohérent dans une coulée linéaire de matériau non cohérent le long d'un chemin de restauration du revêtement de la route (A), du type comprenant frontalement deux bras avec des moyens pour la récolte du matériau non cohérent (23) et un moyen de transport (24) sur

une mélangeuse en aval (C), dans laquelle, entre les roues antérieures ou rails antérieurs et roues postérieures ou rails postérieurs de la machine, des moyens d'aspiration (SA) sont installés pour aspirer tout le matériau granulé et la poussière que les moyens de ramassage antérieurs (23) n'étaient pas capable de récolter du revêtement routier situé en-dessous,

caractérisée en ce que ledit moyen d'aspiration (SA) comprend une bouche d'aspiration étendue transversalement placée centralement (91) et deux bouches d'aspiration étendues placées latéralement (91') mobiles et réglables sur leur distance et s'étendant sur une largeur telle à couvrir une partie de la bouche centrale (91) et s'avancant au moins au-delà de la bouche centrale (91).

2. Machine selon la revendication 1., **caractérisée en ce que** lesdites bouches d'aspiration placées latéralement (91') sont rétractables dans ladite largeur de la bouche d'aspiration centrale (93).

3. Machine selon revendication 2, **caractérisée en ce que** ladite bouche d'aspiration placée centralement (91) est la bouche antérieure tandis que lesdites deux bouches d'aspiration placées latéralement (91'), sont placées derrière la première par rapport à la direction d'avancement.

4. Machine selon les revendications 2 ou 3, **caractérisée en ce que** lesdites bouches d'aspiration placées latéralement (91') sont alignées.

5. Machine selon l'une quelconque des revendications antérieures, **caractérisée en ce que** lesdites bouches d'aspiration (91, 91') sont connectées à des moyens d'aspiration pour la canalisation (92-93) par des conduits flexibles (96).

6. Machine selon la revendication 5, **caractérisée en ce que** lesdits conduits flexibles (96) sont dirigés vers l'arrière.

7. Machine selon les revendications 2 ou 3, **caractérisée en ce que** lesdites bouches d'aspiration (91, 91') sont connectées à un groupe d'aspiration (93) précédé par un réservoir de décantation (92).

8. Machine selon l'une quelconque des revendications antérieures, **caractérisée en ce que** lesdites bouches d'aspiration (91, 91') sont suspendues par des bras articulés (94, 94') inclinés vers l'arrière par rapport à la direction d'avancement.

9. Machine selon la revendication 8, **caractérisée en ce qu'**au moins l'un desdits bras articulés a la forme

d'un parallélogramme (94').

10. Machine selon l'une quelconque des revendications antérieures,

caractérisée en ce que lesdites bouches d'aspiration (91, 91') impliquent, en aval par rapport à la direction d'avancement, de petites roues (95) qui reposent sur le revêtement routier, placées derrière les bouches d'aspiration respectives (91, 91').

11. Machine selon l'une quelconque des revendications 7 - 10, **caractérisée en ce que** ledit réservoir de décantation (92) et les moyens d'aspiration (93) sont substantiellement placés devant, avec les moyens de récolte en arrière (23-23') et au-dessus d'une bande de transport respectives (24), qui s'élève d'au-dessous et de l'arrière des moyens de récolte antérieurs (23), se lève inclinée vers l'arrière et dépasse en arrière avec une saillie pour la décharge en aval (24').

12. Machine selon la revendication 11, **caractérisée en ce que** ladite bande de transport (24) décharge en aval (24') sur une trémie (T) dans une machine opératrice remorquée à partir de l'arrière (B-C) dans un système de trémie (20) avec transporteur en-dessous (20').

13. Machine selon l'une quelconque des revendications antérieures, **caractérisée en ce qu'elle** comprend en outre un réservoir pour le liquide (25) à ajouter à un moyen de mixture (3) de la mélangeuse postérieure (C).

14. Machine selon l'une quelconque des revendications précédentes, **caractérisée en ce que** ledit réservoir pour le liquide (25) est équipé de moyens pour le chauffage du liquide contenu (25').

15. Machine selon l'une quelconque des revendications précédentes, **caractérisée en ce qu'elle** est automotrice et dotée d'au moins une position de contrôle antérieure (23') et une attache basculante postérieure pour accrocher une remorque comme mélangeuse (C) ou machine intermédiaire de tamisage et de broyage (B).

16. Machine selon l'une quelconque des revendications précédentes, **caractérisée en ce qu'elle** comprend, devant, deux mâchoires de transport (23) pour la récolte de la coulée linéaire de matériau non cohérent comme matériau à recycler avec cabine de commande surplombante (23').

17. Machine selon la revendication 16, **caractérisée en ce que** lesdites mâchoires (23) ont une première

brosse rotative (231) similaire à un tambour, qui est inclinée et s'étend au-delà de la mâchoire respective.

18. Machine selon les revendications 16 ou 17, **caractérisée en ce que** lesdites mâchoires comprennent au moins deux brosses rotatives verticales de forme similaire à une tasse (232, 233) lesquelles transportent le matériau vers le centre.

19. Machine selon la revendication 18, **caractérisée en ce qu'entre** lesdites mâchoires et après lesdites deux brosses rotatives de forme similaire à une tasse (232,233), deux déflecteurs inclinés réglables opposés (234) sont pourvus de la fonction de transport et de mieux unir la coulée linéaire de matériau non cohérent vers le centre qui concerne la bouche de récolte (235).

20. Train pour la mixture continue et la production de conglomérats de compositions différentes particulièrement pour le revêtement de la route ou la thermorégénération qui comprend une machine en amont pour la récolte de la coulée linéaire de matériau non cohérent selon l'une quelconque des revendications précédentes, le train en outre comprend au moins une mélangeuse remorquée (C) avec :

- une unité de mixture de base qui implique un groupe de mixture (3), associable avec:
- une unité démontable pour l'addition d'un liant solide en poudre (7) interchangeable avec
- une unité alternative démontable pour l'addition d'un liant liquide ou semi-liquide (7a),
- ou vice versa.

21. Train qui implique une mélangeuse selon la revendication 20, **caractérisé en ce qu'il** a un groupe de mixture avec une paire d'arbres substantiellement horizontaux, parallèles l'un à l'autre et rotatifs en opposition, dotés de pales radiales (3.1-3.2).

22. Train selon l'une quelconque des revendications 20-21, **caractérisé en ce qu'il** pourvoit entre ladite machine de récolte de la coulée linéaire de matériau non cohérent et ladite mélangeuse (C), une machine intermédiaire pour travailler à nouveau le matériau à recycler, comprenant des moyens pour le tamisage du matériau à recycler (26), des moyens pour écraser le matériau écarté du tamisage (27) et des moyens pour le transport de tout le matériau, tamisé et écrasé (30), vers ladite mélangeuse postérieure (C).

23. Train selon l'une quelconque des revendications

20-22, **caractérisé en ce que** ladite mélangeuse (C) en amont comprend une trémie de compensation (20) :

- pourvue de moyens pour détecter la quantité de matériau déchargé en elle connectés avec l'opérativité de l'équipement pour un contrôle de l'uniformité d'opération de la circulation continue du matériau; 5
- et en comprenant un système de générateur (6) pour l'alimentation du moteur pour l'opération de l'équipement, et cadre électrique respectif placé en aval. 10

24. Train selon l'une quelconque des revendications 20-23, **caractérisé en ce que** dans ladite mélangeuse (C), ladite unité démontable pour l'addition de poudre liante solide comprend :

- un réservoir (7) avec des pieds latéraux qui font saillie pour être fixés sur une structure (1) qui supporte ledit groupe de mixture; 20
- des moyens de filtrage pour l'entrée de l'air de décharge à l'intérieur du réservoir pendant le chargement du matériau en poudre (9); 25
- des moyens longitudinaux inférieurs consistant en des vis d'Archimède (10) pour recueillir le matériau en poudre dans ledit réservoir (7), associés à des moyens de transport (11, 12) à une trémie de tampon placée à la tête (13), dont la bouche inférieure comprend des moyens de dosage volumétrique (14) qui transportent le matériau sur un convoyeur à vis d'Archimède successif (15) audit groupe de mixture (3). 30

35

25. Train selon l'une quelconque des revendications 20-24, **caractérisé en ce que** ladite unité démontable pour l'addition du liant liquide comprend :

- un ultérieur réservoir (7) avec des pieds latéraux qui dépassent pour être fixés sur une structure (1) qui supporte ledit groupe de mixture (3); 40
- moyens pour le chauffage par un serpentin placé dans un réservoir (18) connecté à 45
- un moyen de chauffage à chaudière placé sur la tête du réservoir (16) équipé de brûleur de combustible placé verticalement à partir de la partie supérieure vers le bas (17), pour chauffer le liquide de l'échangeur central de chaleur dans ledit tuyau (18). 50

55

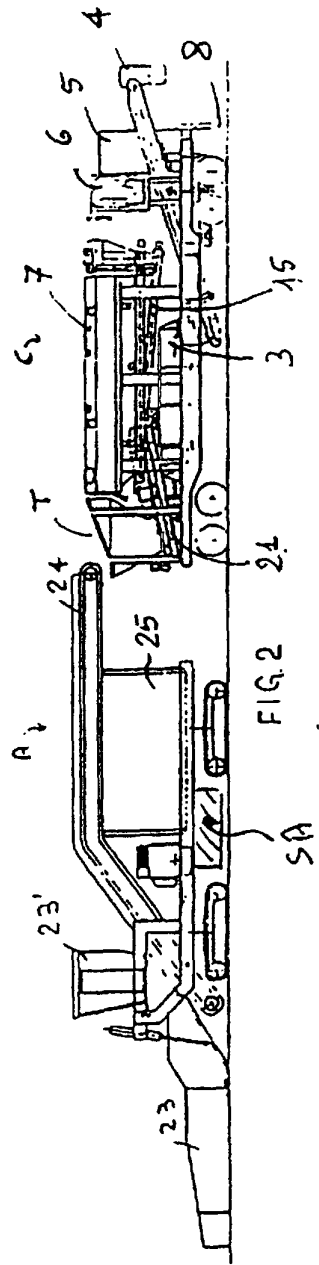
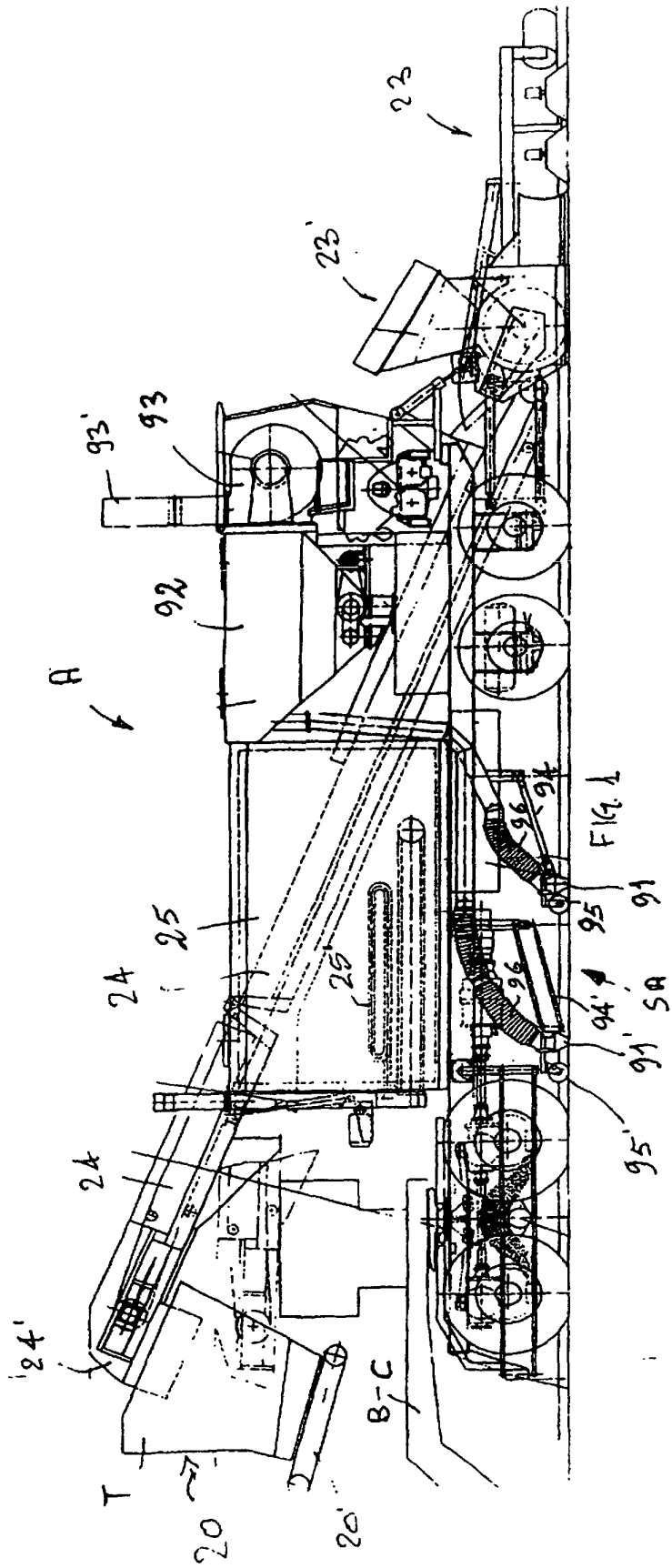

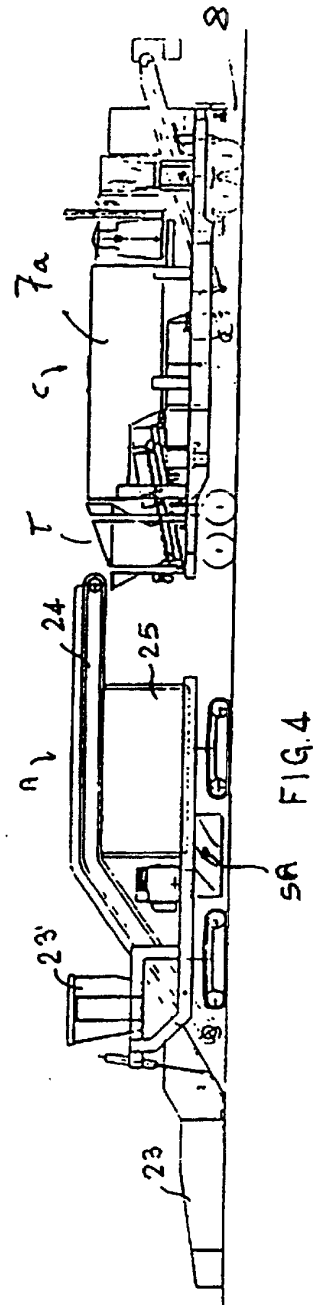
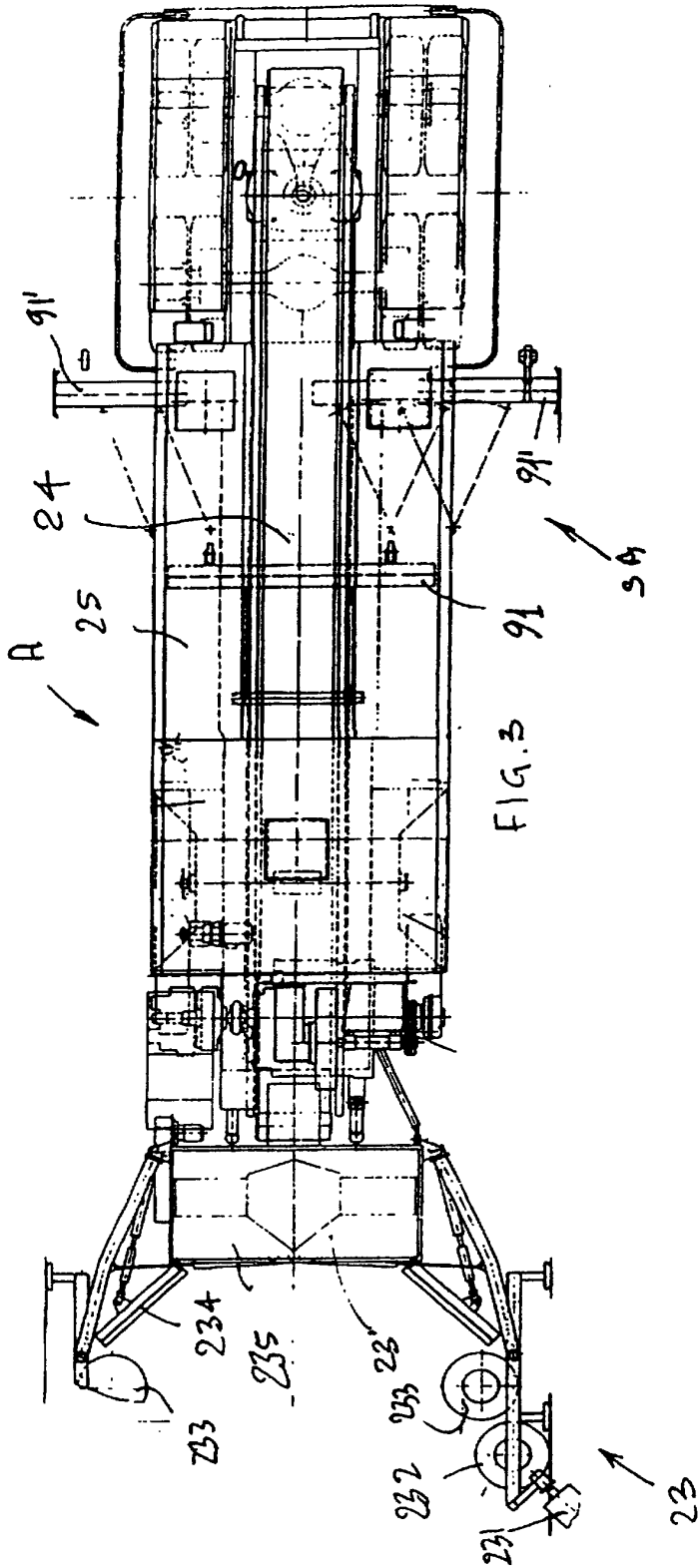

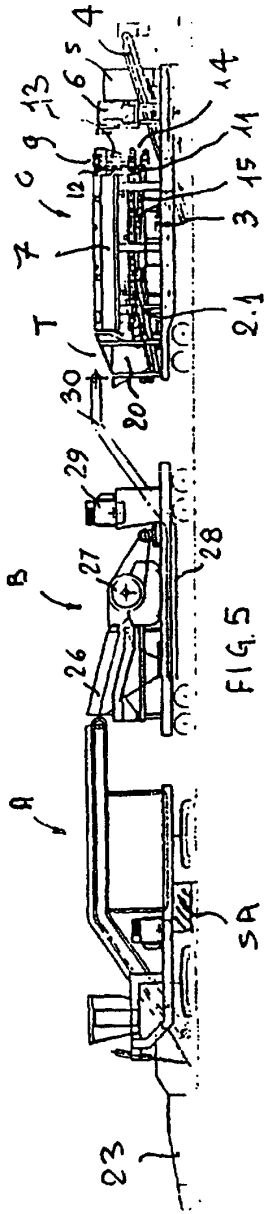

FIG. 5

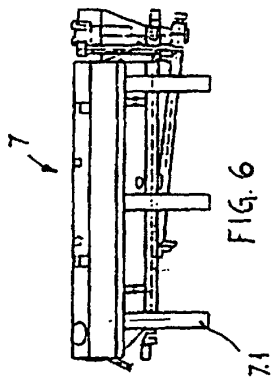

FIG. 6

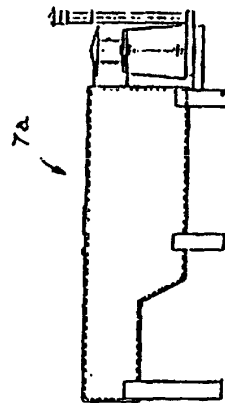

FIG. 7

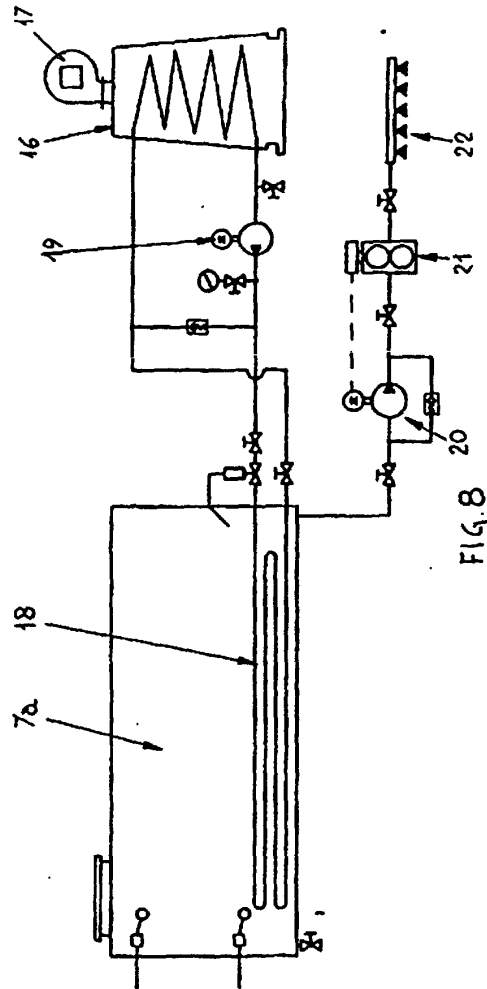

FIG. 8

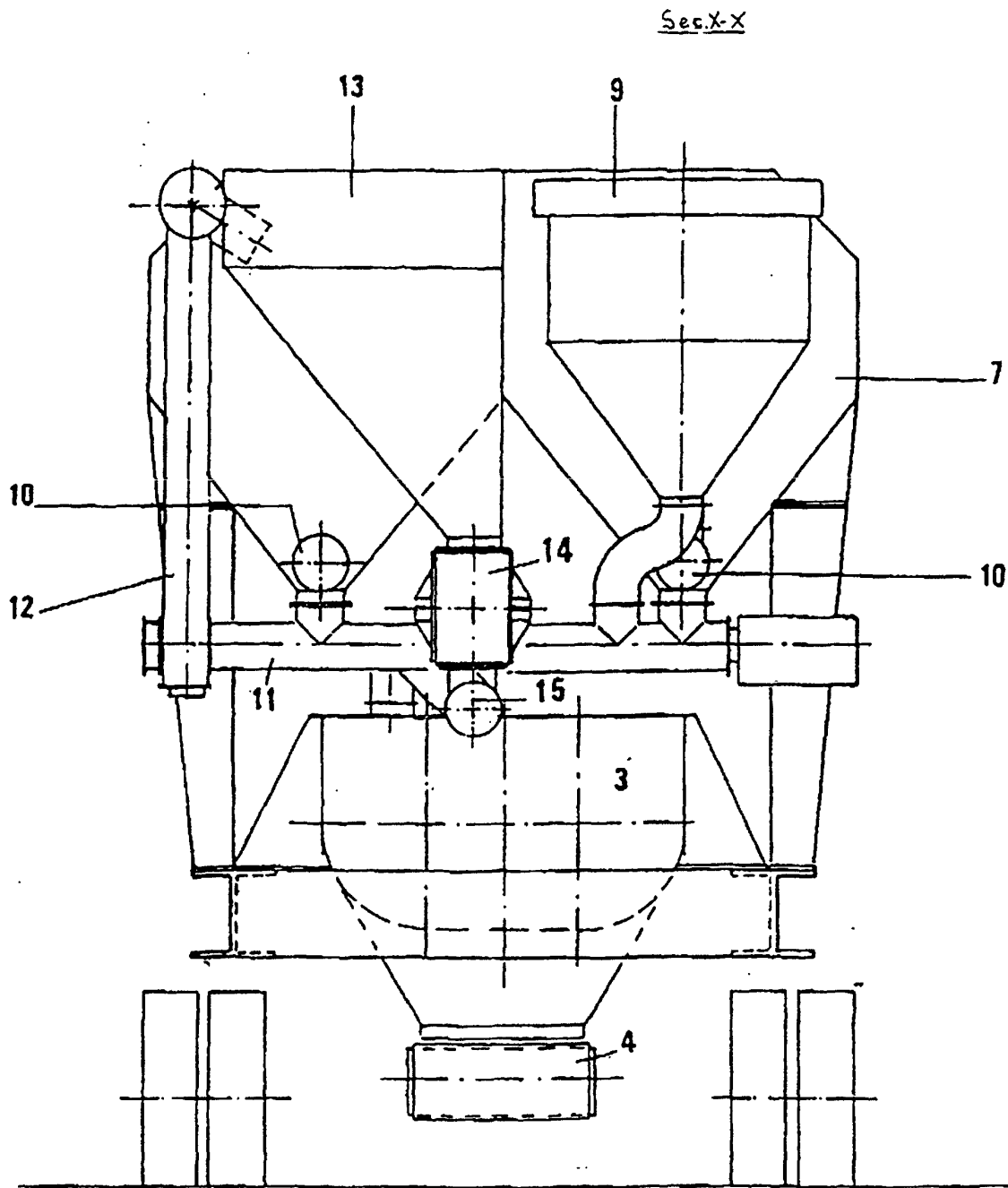

FIG. 9

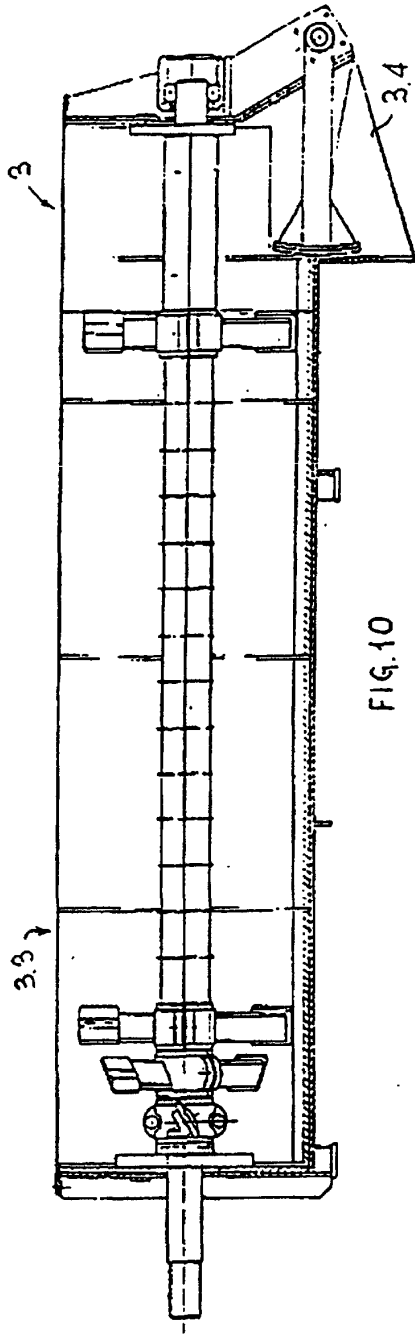

FIG. 10

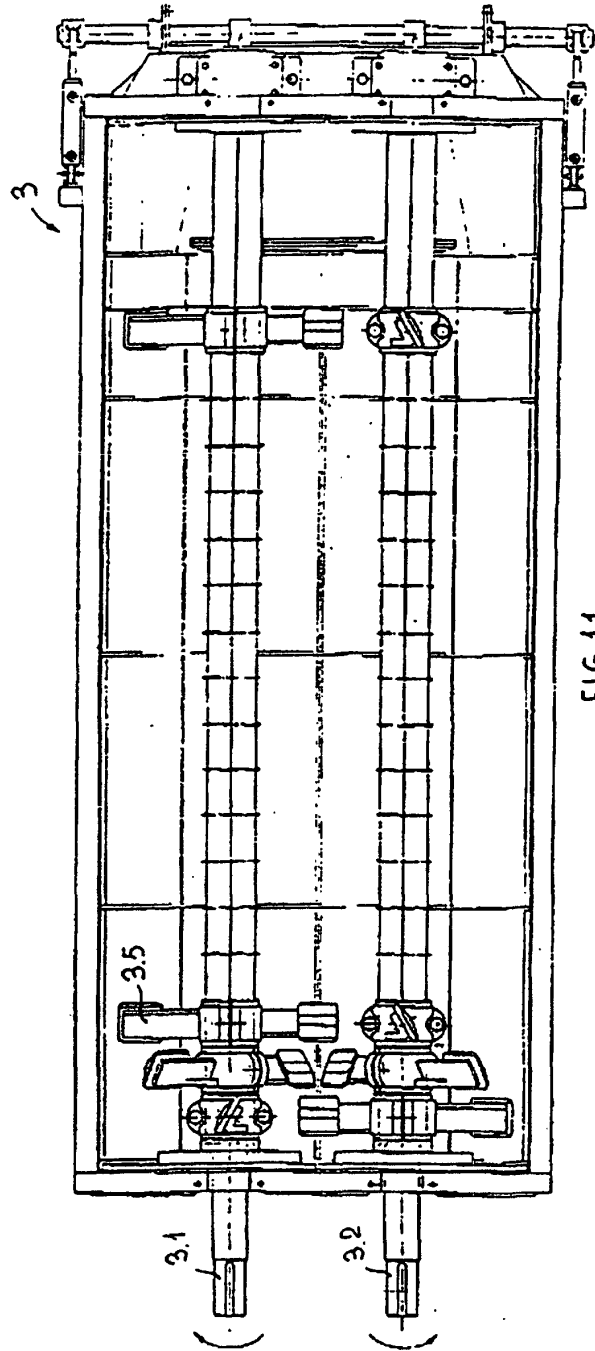

FIG. 11

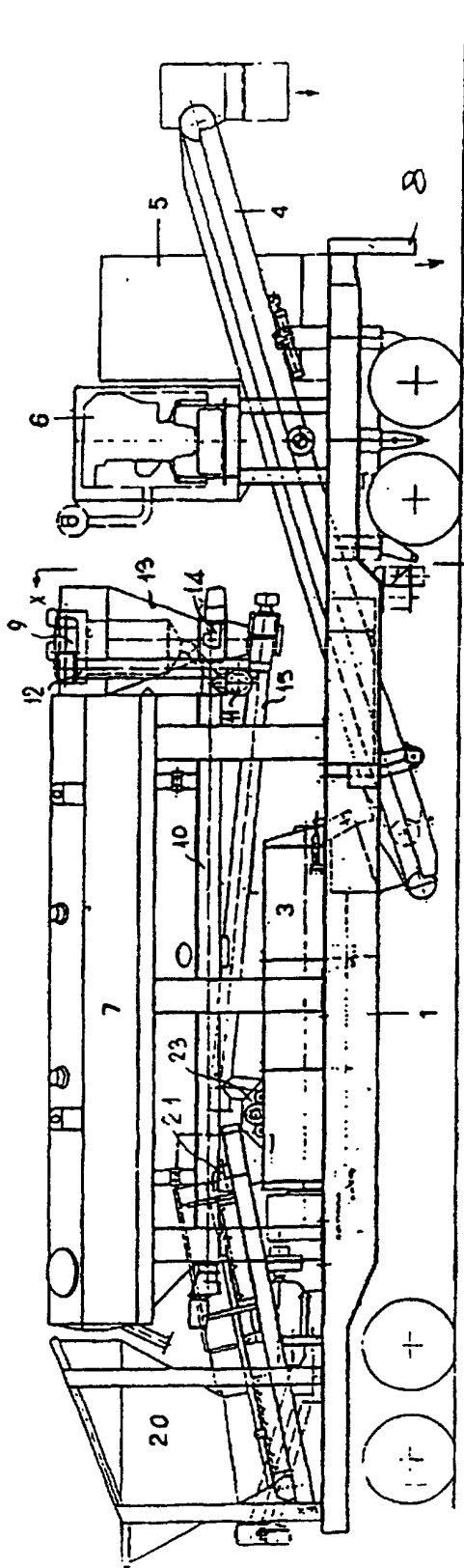

FIG. 12

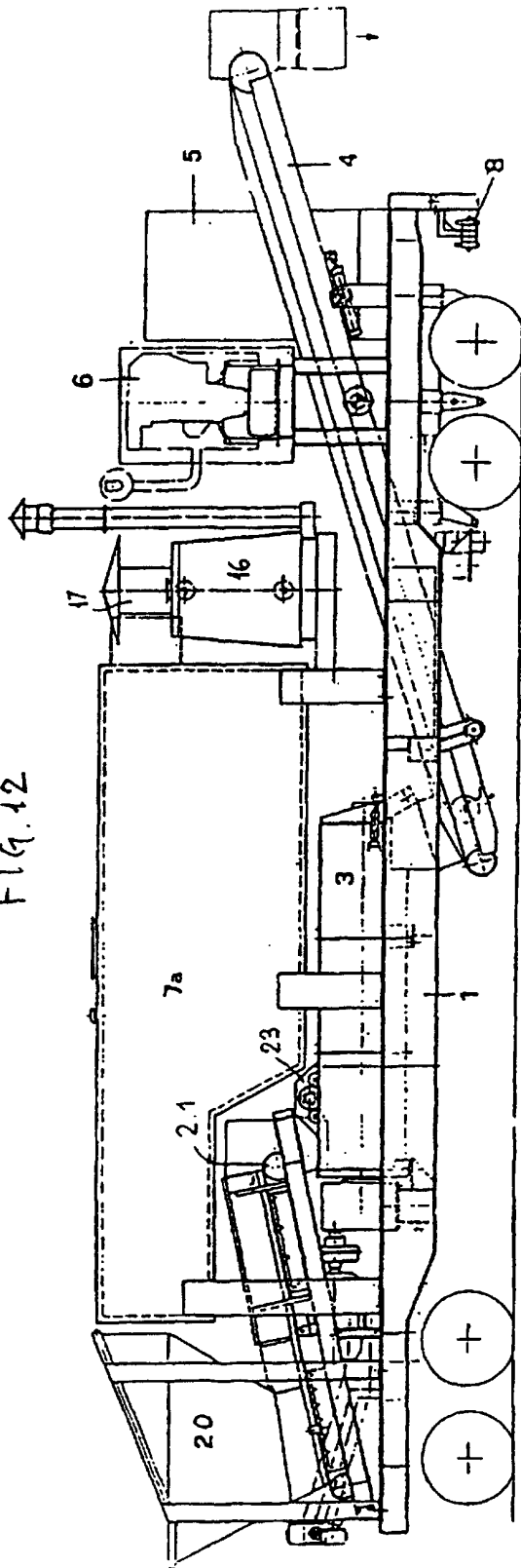

FIG. 13