

(No Model.)

J. YOCOM.
CAST METAL WHEEL.

No. 523,030.

Patented July 17, 1894.

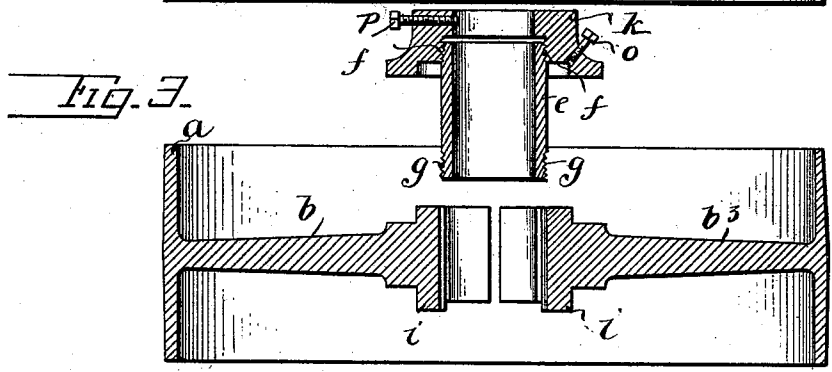
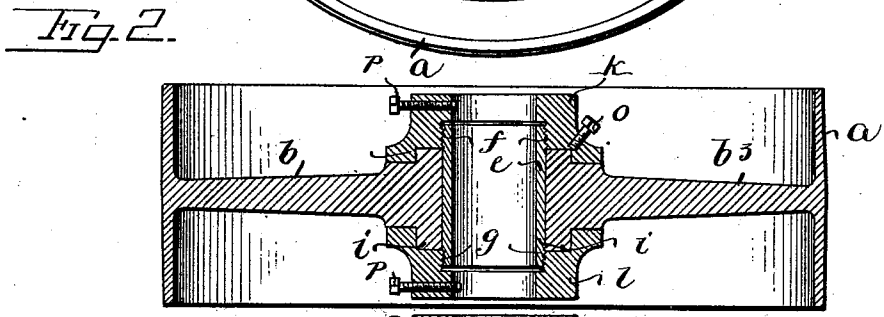
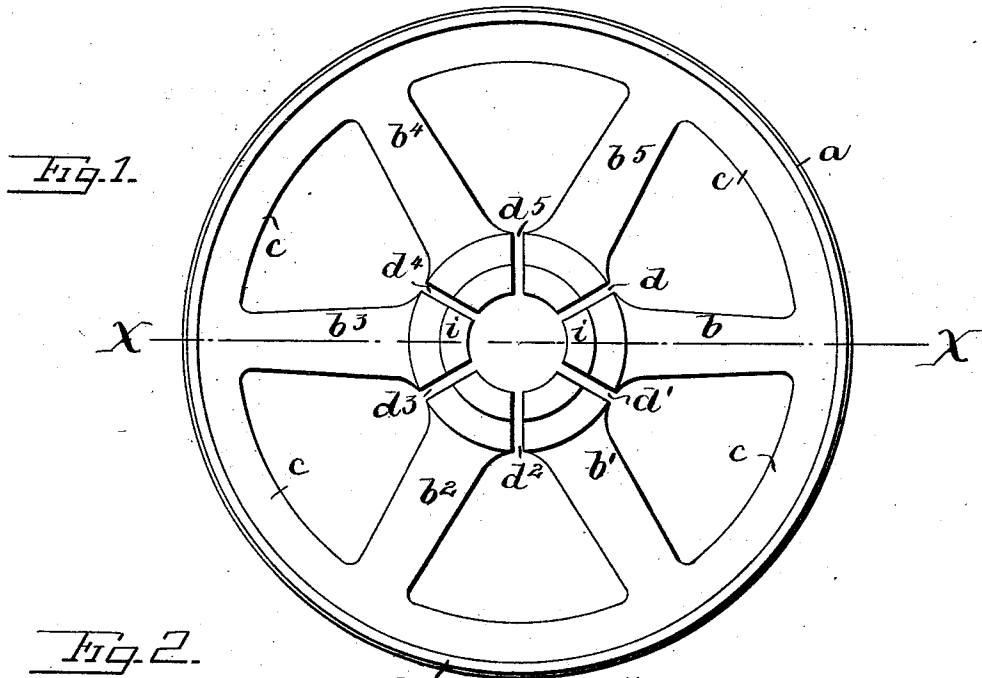

Witnesses:

F. M. Peeler
J. C. Shaw



Inventor.

James Yocom

UNITED STATES PATENT OFFICE.

JAMES YOCOM, OF PHILADELPHIA, PENNSYLVANIA.

CAST-METAL WHEEL.

SPECIFICATION forming part of Letters Patent No. 523,030, dated July 17, 1894.

Application filed March 23, 1894. Serial No. 504,874. (No model.)

To all whom it may concern:

Be it known that I, JAMES YOCOM, a citizen of the United States, residing in the city of Philadelphia, State of Pennsylvania, have invented a new and useful Improvement in Cast-Metal Wheels, of which invention the following is a specification.

A cast metal wheel having its rim, arms and hub cast in a single piece, is, from the time of pouring the metal into the flask, subject to shrinkage strains, which vary in intensity at the different parts, owing to their unequal thickness, variations in their times of cooling; the heaviest parts remaining fluid longest and shrinking last. These strains distort the shape of the wheel; they also weaken the wheel, and oftentimes the point of endurance being passed, the casting breaks before it gets cold.

Various methods have been pursued in foundries for regulating the shrinkage and avoiding the unequal contraction of wheel castings; the usual practice being to judiciously hasten the cooling of heavy parts; but with all such precautions, there has remained present at every "melt" the liability to have, from the causes mentioned, cracks and breaks in the castings. To obviate the waste incident to such cracks and breaks, it has been necessary, in the preparation of patterns for wheel castings, to avoid the use of many desirable forms; thus, for instance, the pattern for an ordinary pulley wheel could not be provided with a continuous flange extending from arm to arm on the inside of the rim, as illustrated in the accompanying drawings, without subjecting the casting to a dangerous liability to break in shrinking.

I have found that in casting wheels, all obstacles to equal shrinking are avoided, and all contractions freed from restraint, when the arms are cast integral with the rim only, or with the rim and interior flange above mentioned, but otherwise free, being divided or separated at the center web or junction of arms, as below set forth.

In the annexed drawings, Figure 1 is a plan of a hubless pulley wheel cast in accordance with my invention. Fig. 2 is a cross-section of said wheel on line x, x of Fig. 1, the tube

e and nuts k, l together constituting the hub, being shown in position; and Fig. 3 is a similar view, with the separable parts composing the hub removed.

Similar letters of reference denote similar parts in the several views.

a represents the rim of the pulley; $b, b', b^2, b^3, b^4, b^5$, the arms, and c a flange extending continuously around from arm to arm inside the rim. It is to be understood that the flange c may be cast with the rim a , or the flange may be omitted, as desired.

$d, d', d^2, d^3, d^4, d^5$, represent open spaces, separating the arms at the center web of the wheel. The spaces d, d' , &c., separating the arms, are produced by coring in the usual way, preparatory to casting. These spaces are afterward filled with molten lead or any soft metal or moldable material, and the wheel finished up in an ordinary lathe.

e is a tube or nipple passing through the central hole of the wheel, as shown; it is provided with screw threads f and g , for right and left hand screws.

i represents clutch teeth projecting from two of the arms. Each of the arms may be provided with a clutch tooth, if desired; but it will answer the purpose if only a single arm be so provided.

k and l are screw nuts which engage the screw threads f and g of tube e .

m and n are recesses in nut l , adapted to fit and engage clutch teeth i , the number of recesses corresponding to the number of clutch teeth used.

o is a set-screw for securing nut k in position; p , set-screws for securing the wheel to the shaft upon which it may be placed.

In assembling the parts of the hub, I prefer to apply nut l to tube e , then inserting the tube in the central hole of the wheel, adjusting the clutch recesses on the clutch teeth, then screwing nut k on the tube and finally tightening set-screw o .

The tube e is shown to fit the central hole of the wheel, but this is not essential.

While I prefer to make use of the tube or nipple for fastening the parts of the hub to the center web of the wheel as described,

through-bolts might be employed in place of said nipple; in fact, there are many different ways, well known to mechanics skilled in the art, by which the hub can be fastened to the center web.

5 Instead of coring, with the view to separate at the center web, each individual arm from the arm next to it on either side, as shown, some of the cores may be omitted; thus, omitting cores for spaces d' , d^3 , and d^5 , the arms 10 b and b' come from the flask united at the center web; so also arms b^2 and b^3 , and so also arms b^4 and b^5 ; but the best results are ob-

tained by coring so as to individuate each of the several arms at the center web as shown. 15

I claim—

A cast metal hubless wheel, the arms whereof are integral with the rim, but separated at the center web by intervening open spaces into three or more portions, independent of 20 each other, in combination with the tube e and nuts k , l , substantially as set forth.

JAMES YOCOM.

Witnesses:

F. M. PEELER,
JOS. B. WILLITS.