

C. E. WILLIAMS.
SELF BALANCED THREAD BOARD.
APPLICATION FILED JUNE 14, 1910.

998,441.

Patented July 18, 1911.

2 SHEETS—SHEET 1.

Fig. 1

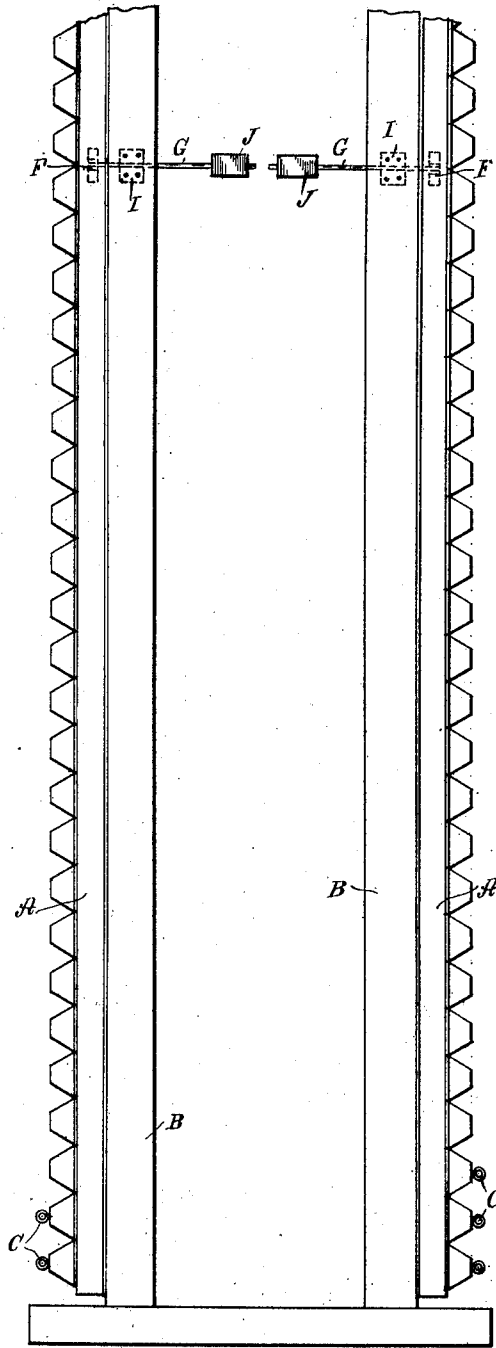

WITNESSES:
H. D. Smith
Henry Hooster

INVENTOR
Charles E. Williams
BY *Munn & Co.*
ATTORNEYS

C. E. WILLIAMS.
 SELF BALANCED THREAD BOARD.
 APPLICATION FILED JUNE 14, 1910.

998,441.

Patented July 18, 1911.

2 SHEETS—SHEET 2.

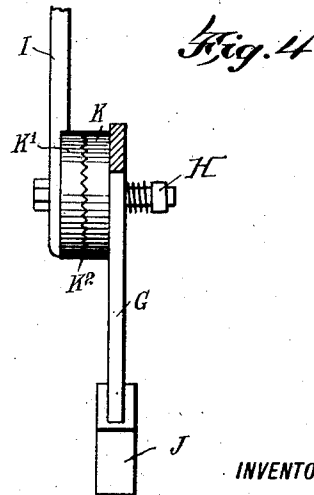
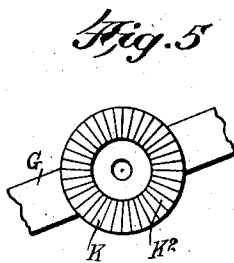
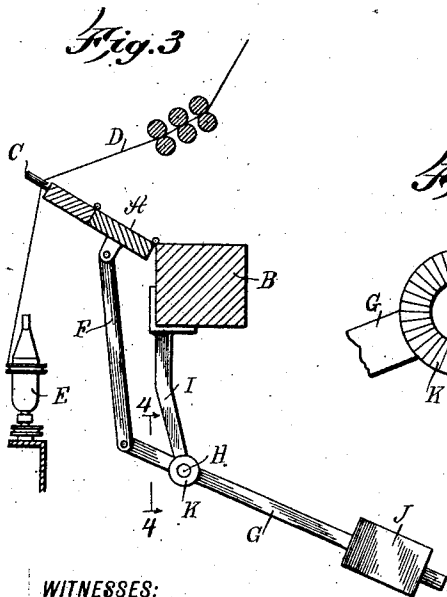
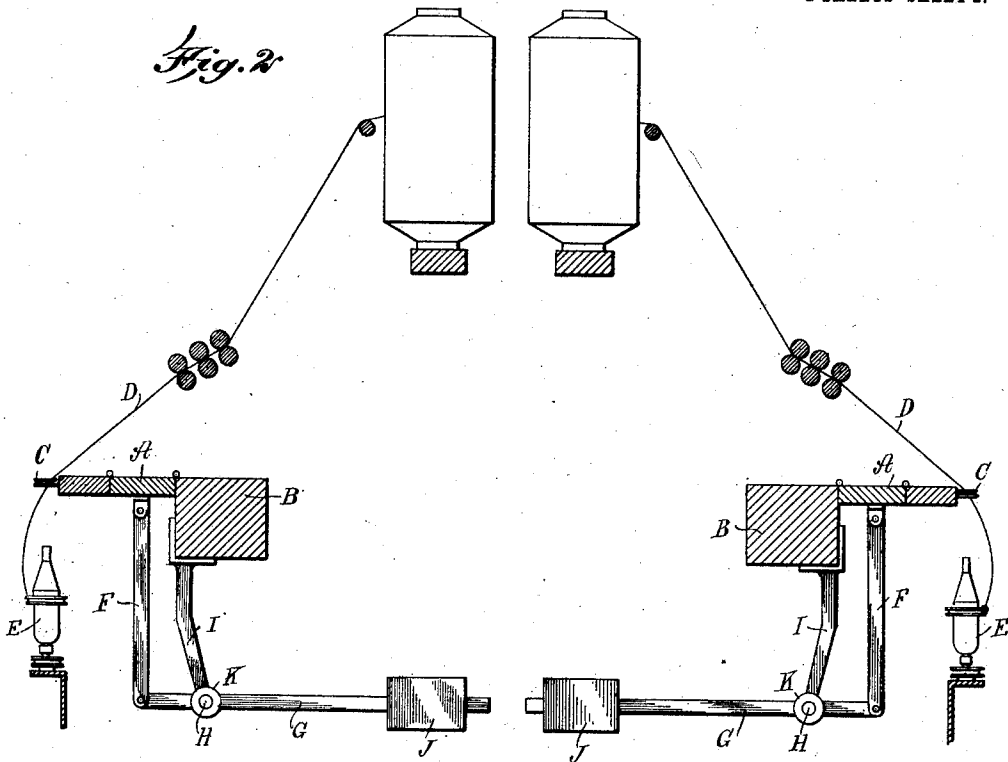

WITNESSES:
F. H. Smith
Henry H. Smith

INVENTOR
Charles E. Williams
 BY *Munn Co*
 ATTORNEYS

UNITED STATES PATENT OFFICE.

CHARLES EDWIN WILLIAMS, OF GREENVILLE, RHODE ISLAND.

SELF-BALANCED THREAD-BOARD.

998,441.

Specification of Letters Patent.

Patented July 18, 1911.

Application filed June 14, 1910. Serial No. 566,760.

To all whom it may concern:

Be it known that I, CHARLES E. WILLIAMS, a citizen of the United States, and a resident of Greenville, in the county of Providence and State of Rhode Island, have invented a new and Improved Self-Balanced Thread-Board, of which the following is a full, clear, and exact description.

The invention relates to ring spinning frames, and its object is to provide a new and improved self-balanced thread board, arranged to permit raising or lowering it conveniently by the doffer taking hold of the thread board at any point in the length thereof, and swinging the board up or down, the board in any one of its positions being securely locked in place.

In order to produce the desired result, use is made of a counterbalancing lever, a link connecting the said lever with the thread board, and a locking device for holding the said lever locked in whatever position it is moved to, on the operator swinging the thread board into a desired position.

A practical embodiment of the invention is represented in the accompanying drawings forming a part of this specification, in which similar characters of reference indicate corresponding parts in all the views.

Figure 1 is a plan view of a pair of self-balanced thread boards in position on their rails; Fig. 2 is a cross section of a ring-spinning frame provided with the counter-balanced thread board; Fig. 3 is a like view of the same showing the thread board swung upward; Fig. 4 is an enlarged sectional front elevation of the counterbalancing lever, its support and lock, the section being on the line 4—4 of Fig. 3; and Fig. 5 is an enlarged face view of the locking disk on the counterbalancing lever.

The ring-spinning frame is provided with the thread boards A, A, hinged at their inner ends to the rails B forming part of the frame of the machine, and the outer ends of the thread boards A carry the usual eyes C for the passage of the threads or yarns D adapted to wind on the bobbins E. Each of the thread boards A is pivotally connected at its under side by a link F with a counterbalancing lever G, fulcrumed on a pivot H carried by a bracket I attached to the corresponding rail B, the said link F being preferably connected with the thread board A at the middle thereof, and the said lever G is provided with an adjustable weight to coun-

terbalance the thread board A to permit the operator to conveniently swing the same from the usual normal or horizontal position, shown in Fig. 2, into an upward position as indicated in Fig. 3. By arranging the counterbalancing mechanism at the middle of the thread board A, it is evident that the attendant in charge of the machine can readily take hold of the thread board at any point of the length thereof, to swing the thread board up or down to the desired position without being required to take hold of the mechanism shown and described.

In order to lock the thread board A in whatever position it is moved to by the attendant, use is made of a locking device, preferably in the form of two disks K and K', arranged on the fulcrum of the counterbalancing lever G, the disk K being attached to or forming part of the lever G, while the disk K' is fixed and preferably forms part of the bracket I. The contacting faces of the disks K and K' are provided with radial notches or teeth K², as plainly indicated in Figs. 4 and 5, so that the disks K and K' readily interlock and thus hold the lever G in whatever position it is moved to, on the operator imparting a swinging motion to the thread board A.

It is understood that although the disks K and K' lock the lever G and consequently the thread board A in adjusted position, it requires but comparatively little pressure on the thread board by the attendant to turn the disk K on the disk K', and to re-interlock the disks K and K' as soon as the operator releases the pressure on the thread board A.

From the foregoing it will be seen that the thread board is self-balanced and can be readily adjusted by the attendant of the machine at any point in the length of the thread board, so that the attendant is not required to move to any one place in order to move the thread board A into a desired position.

By arranging the notches or teeth in the interlocking disks K and K', as shown in Figs. 4 and 5, the thread board A can be swung into the desired horizontal or upward position, the thread board A being automatically locked in the adjusted position.

When making slack twisted yarns, the thread board can be raised slightly by the attendant and locked in the adjusted position without the use of extra fastening or hold-devices, such as paper, waste, disks

and the like, as heretofore used for the purpose.

The self-balanced device shown and described may be readily applied to the thread boards of ring spinning frames now in use, and the self-balanced device when in use is completely out of the way of any of the parts, and hence does not interfere with the proper working of the machine or with the attendant in charge of the machine.

Having thus described my invention, I claim as new and desire to secure by Letters Patent:

1. In a ring spinning machine, the combination with a hinged thread board, of a pivoted and counterbalanced lever, a link connecting the said lever with the thread board, and a locking device at the pivot of the lever for holding the said lever locked in whatever position it is moved to on the operator swinging the thread board into a desired position.

2. In a ring spinning machine, the combination with the frame and a hinged thread board, of a counterbalancing lever, a link connecting the said lever with the thread board, and disks at the fulcrum of the said lever and engaging each other to lock the lever in the position to which it is moved, one of the disks being fixed and carried by the frame and the other forming part of the lever.

3. In a ring spinning machine, the combination with a hinged thread board, of a counterbalancing lever, a link pivoted to the said lever and to the under side of the thread board approximately at the center of length thereof, a bracket on which the said lever is fulcrumed, and a pair of interlocking notched disks at the fulcrum of the lever on the bracket, one of the disks forming a fixed part of the lever and the other disk forming a fixed part of the bracket.

4. In a ring spinning machine, the combination with the frame, and a thread board hinged to the frame, of a bracket secured to and depending from the frame, said bracket having an apertured disk at its lower end, a lever having an apertured disk intermediate of its ends, said disk engaging the disk of the bracket, a bolt passing through said disks and pivoting the lever to the bracket, a link connecting one end of the lever with the underside of the thread board at about the middle thereof, and an adjustable weight on the other end of said lever.

In testimony whereof I have signed my name to this specification in the presence of two subscribing witnesses.

CHARLES EDWIN WILLIAMS.

Witnesses:

CLARENCE E. KIMBALL,
SAMUEL H. JENKINS.