

June 1, 1926.

1,586,785

E. E. CURTIS

BRUSH

Filed April 15, 1924

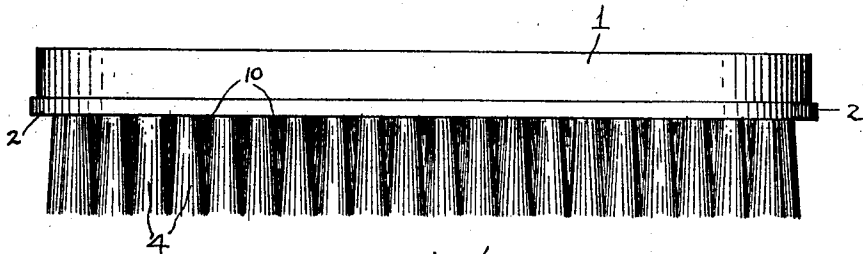

Fig. 1

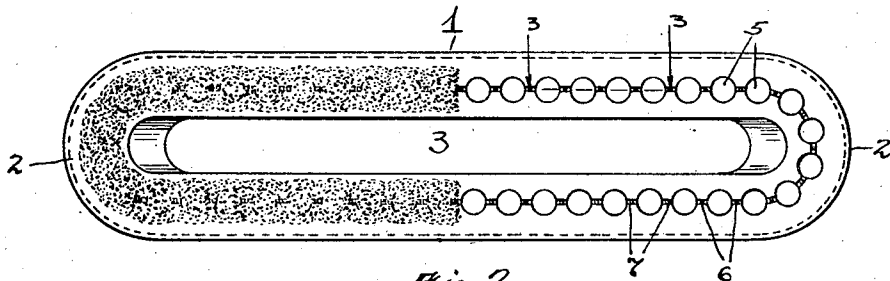

Fig. 2

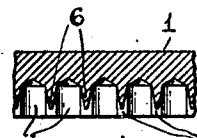

Fig. 3

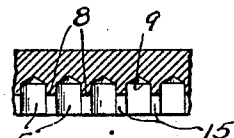

Fig. 4

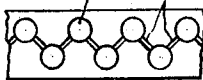

Fig. 7

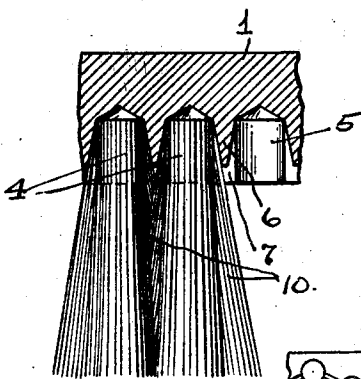

Fig. 5

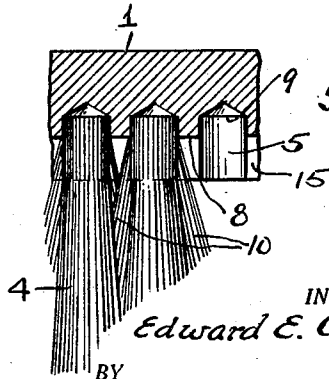

Fig. 6

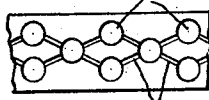

Fig. 8

INVENTOR.
Edward E. Curtis
BY
Jay. Oberlin & Fay
ATTORNEYS

UNITED STATES PATENT OFFICE.

EDWARD E. CURTIS, OF LAKEWOOD, OHIO, ASSIGNOR TO THE OSBORN MANUFACTURING COMPANY, OF CLEVELAND, OHIO, A CORPORATION OF OHIO.

BRUSH.

Application filed April 15, 1924. Serial No. 706,636.

The present invention relates to the construction of tufted brushes, and more particularly to the construction of a brush base whereby the tufts of bristles are enabled to intermingle with adjacent tufts so as to form a brush wall substantially closed from the base to the end of the bristles. This type of brush is particularly adapted for use in connection with vacuum sweepers where it is desired to have a closed ring of brush material which is not provided with openings near the tuft sockets but where the brush material forms a complete wall and thus tends to shut off the air going through the bristles and force the air drawn through the center slot in the brush base to pass by the ends of the brush between the bristles and the material to be cleaned. To the accomplishment of the foregoing and related ends, said invention, then, consists of the means hereinafter fully described and particularly pointed out in the claims.

The annexed drawing and the following description set forth in detail certain mechanism embodying the invention, such disclosed means constituting, however, but one of various mechanical forms in which the principle of the invention may be used.

In said annexed drawing:—

Fig. 1 is an elevational view of a brush embodying the present invention; Fig. 2 is a bottom plan view of the brush, showing part of the bristles removed; Fig. 3 is a sectional view of the line 3—3 of Fig. 2; Fig. 4 is a sectional view similar to Fig. 3 but showing a modified form of slot; Figs. 5 and 6 are sectional views similar to Figs. 3 and 4 respectively, but on an enlarged scale and showing the bristles in position in the sockets and slots; and Figs. 7 and 8 are bottom plan views similar to that of Fig. 2 but showing broken sections of two modified forms of my improved brush.

The present brush, as shown in Figs. 1 and 2, is of the type generally employed in connection with vacuum sweeper attachments and the like, and comprises a relatively thin elongated base 1 having rounded ends 2 and a central slot or opening 3. The brush is formed by placing tufts 4 of brush material in suitable holes or sockets 5 drilled or otherwise formed in the base and spaced as close together as possible without leaving the sections 6 between the holes so thin that they

will break out when the tufts are inserted. These tuft holes may be evenly spaced in a continuous line as shown in Fig. 2, or they may be disposed in zig-zag fashion as shown in Fig. 7, or be specially grouped as shown in Fig. 8. Generally, the tufts are arranged so as to result in continuous closed lines of circular or non-circular form, all such being conveniently designated by the term "ring". Whatever the disposition or grouping of the holes 5, sections 6 between such holes are intersected by slots 7, the slots extending below the surface of the brush for approximately $\frac{1}{8}$ of an inch and then being tapered sidewise to substantially the bottom of the tuft sockets. In the form shown in Figs. 4 and 6, each slot instead of being tapered is cut through from hole to hole so that the bottom 8 is in a plane parallel with the surface of the base and the bottom of the slot is spaced above the bottom 9 of the tuft holes approximately two-thirds of the distance down from the surface of the base.

The tufts 4 of bristles are inserted in the tuft holes in the usual manner, but the bristles 10 adjacent the slot at each side of the hole fall sidewise slightly into the slot and against the inclined wall thereof so as to bush the brush out in the plane of the bristles, but the angle of the wall of the slot is such as to prevent the bristles 10 from falling down far enough to interfere with the insertion of the next adjacent tuft. By this method of construction, the finished brush is formed of a single row of tufts having at the bottom a closing row of bristles between the tufts and thus a brush is formed which is completely closed throughout the extent of the bristles.

In the form shown in Figs. 4 and 6, instead of having the slots cut with inclined walls, the slots 15 are cut between each two tuft sockets, but these slots do not extend to the bottom of the socket, and thus a tuft 4 inserted in the socket does not tend to completely fall over into the slot but assumes the position shown in Fig. 6, the bristles 10 angling out only from the base of the slot which thus controls the angle of inclination and the finished effect is the same as that obtained by the inverted V-shaped slot used in the first form.

There is also a tendency in the present brush construction for the bristle surface

or the ends of the bristles to bush out into a slightly wider surface or face than in the usual form where no connecting slots are employed. This bushing seems to be due to the effect of the bristles which angle out of the slots pressing against each other and against the rest of the tuft of bristles so as to bush it sidewise. By this construction a brush is obtained which presents a completely closed side wall with a relatively bushy brushing surface through and past which the air may be drawn when the device is used in a brushing attachment for vacuum cleaners.

Other modes of applying the principle of the invention may be employed instead of the one explained, change being made as regards the mechanism herein disclosed, provided the means stated by any of the following claims or the equivalent of such stated means be employed.

I therefore particularly point out and distinctly claim as my invention:—

1. In a brush, the combination of a back provided with a ring of tuft sockets, and slots cut between such sockets and communicating therewith, and tufts of bristles inserted in such sockets, some of the side bristles of such tufts inclining in said slots to form a ring of bristles closed from the ends to the brush back.

2. In a brush, the combination of a back provided with a center slot and a ring of tuft apertures therearound, communicating

slots cut between adjacent apertures, tufts of bristles mounted in such apertures, the side bristles adjacent such slots leaning therein so as to intermingle with the leaning bristles of adjacent tufts to form a ring of bristles around such central slot closed from the brush back to the bristle ends.

3. A brush back consisting of a member having a centrally disposed slot and a ring of tuft apertures concentrically spaced with respect to such slot, each aperture being provided on each adjacent side with a narrow slot inclined upwardly and opening into the slot from the adjacent aperture below the level of the surface of the brush back.

4. A brush consisting of a member having a centrally disposed slot and a ring of tuft sockets concentrically spaced with respect to such slot, the adjacent walls of the sockets being provided with a narrow slot inclined upwardly and communicating with the slot from the adjacent socket below the surface of the brush back and tufts of bristles mounted in said sockets, some of the side bristles of each tuft leaning into said slots and intermingling with the leaning bristles of the adjacent tufts below the surface of the brush back to form a closed bristle ring around such centrally disposed slot.

Signed by me this 7th day of April, 1924.

EDWARD E. CURTIS.