



(86) Date de dépôt PCT/PCT Filing Date: 2018/04/17  
 (87) Date publication PCT/PCT Publication Date: 2018/11/01  
 (45) Date de délivrance/Issue Date: 2023/01/24  
 (85) Entrée phase nationale/National Entry: 2019/07/19  
 (86) N° demande PCT/PCT Application No.: US 2018/027897  
 (87) N° publication PCT/PCT Publication No.: 2018/200252  
 (30) Priorité/Priority: 2017/04/25 (US15/496,604)

(51) Cl.Int./Int.Cl. *G09G 3/20* (2006.01),  
*G09G 3/34* (2006.01)

(72) Inventeurs/Inventors:  
 LIN, CRAIG, US;  
 HUANG, JO-CHENG, US;  
 CHEN, HENG-CHE, US;  
 LAXTON, PETER B., US;  
 WANG, MING, US;  
 CHENG, PING-YUEH, US;  
 ZANG, HONGMEI, US

(73) Propriétaire/Owner:  
 E INK CALIFORNIA, LLC, US

(74) Agent: SMART & BIGGAR LP

(54) Titre : PROCÉDES DE PILOTAGE DE DISPOSITIF D’AFFICHAGE COULEUR  
 (54) Title: DRIVING METHODS FOR COLOR DISPLAY DEVICE

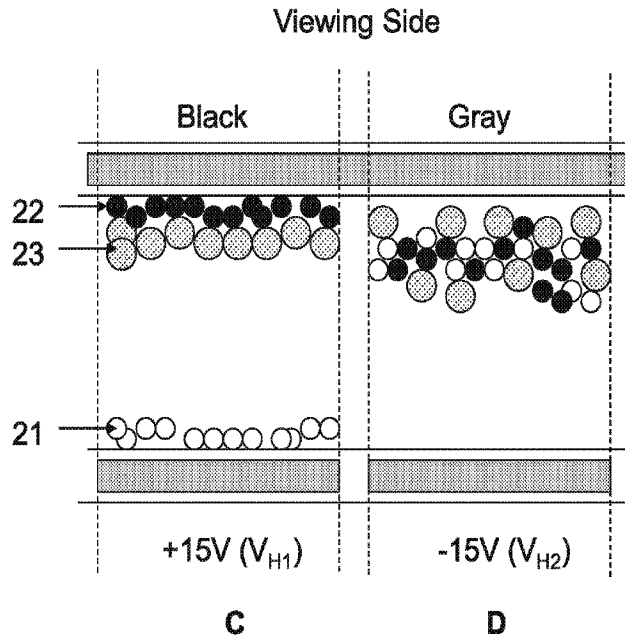

(57) Abrégé/Abstract:

The present invention is directed to driving methods for a color display device which can display high quality color states. The display device utilizes an electrophoretic fluid which comprises three types of pigment particles having different optical characteristics, and provides for displaying at a viewing surface not only the colors of the three types of particles but also the colors of binary mixtures thereof.

(12) INTERNATIONAL APPLICATION PUBLISHED UNDER THE PATENT COOPERATION TREATY (PCT)

(19) World Intellectual Property Organization  
International Bureau



(10) International Publication Number  
**WO 2018/200252 A1**

(43) International Publication Date  
01 November 2018 (01.11.2018)

- (51) International Patent Classification:  
*G09G 3/20* (2006.01)      *G09G 3/34* (2006.01)
- (21) International Application Number:  
PCT/US2018/027897
- (22) International Filing Date:  
17 April 2018 (17.04.2018)
- (25) Filing Language: English
- (26) Publication Language: English
- (30) Priority Data:  
15/496,604      25 April 2017 (25.04.2017)      US
- (71) Applicant: **E INK CALIFORNIA, LLC** [US/US]; 47485 Seabridge Drive, Fremont, California 94538 (US).
- (72) Inventors: **LIN, Craig**; c/o E Ink California, LLC, 47485 Seabridge Drive, Fremont, California 94538 (US). **HUANG, Jo-Cheng**; c/o E Ink California, LLC, 47485 Seabridge Drive, Fremont, California 94538 (US). **CHEN, Heng-Che**; c/o E Ink California, LLC, 47485 Seabridge Drive, Fremont, California 94538 (US). **LAXTON, Peter B.**; c/o E Ink California, LLC, 47485 Seabridge Drive, Fre-

mont, California 94538 (US). **WANG, Ming**; c/o E Ink California, LLC, 47485 Seabridge Drive, Fremont, California 94538 (US). **CHENG, Ping-Yueh**; c/o E Ink California, LLC, 47485 Seabridge Drive, Fremont, California 94538 (US). **ZANG, HongMei**; c/o E Ink California, LLC, 47485 Seabridge Drive, Fremont, California 94538 (US).

- (74) Agent: **BEAN, Brian D.**; E Ink Corporation, 1000 Technology Park Drive, Billerica, Massachusetts 01821-4165 (US).
- (81) Designated States (*unless otherwise indicated, for every kind of national protection available*): AE, AG, AL, AM, AO, AT, AU, AZ, BA, BB, BG, BH, BN, BR, BW, BY, BZ, CA, CH, CL, CN, CO, CR, CU, CZ, DE, DJ, DK, DM, DO, DZ, EC, EE, EG, ES, FI, GB, GD, GE, GH, GM, GT, HN, HR, HU, ID, IL, IN, IR, IS, JO, JP, KE, KG, KH, KN, KP, KR, KW, KZ, LA, LC, LK, LR, LS, LU, LY, MA, MD, ME, MG, MK, MN, MW, MX, MY, MZ, NA, NG, NI, NO, NZ, OM, PA, PE, PG, PH, PL, PT, QA, RO, RS, RU, RW, SA, SC, SD, SE, SG, SK, SL, SM, ST, SV, SY, TH, TJ, TM, TN, TR, TT, TZ, UA, UG, US, UZ, VC, VN, ZA, ZM, ZW.
- (84) Designated States (*unless otherwise indicated, for every kind of regional protection available*): ARIPO (BW, GH,

(54) Title: DRIVING METHODS FOR COLOR DISPLAY DEVICE

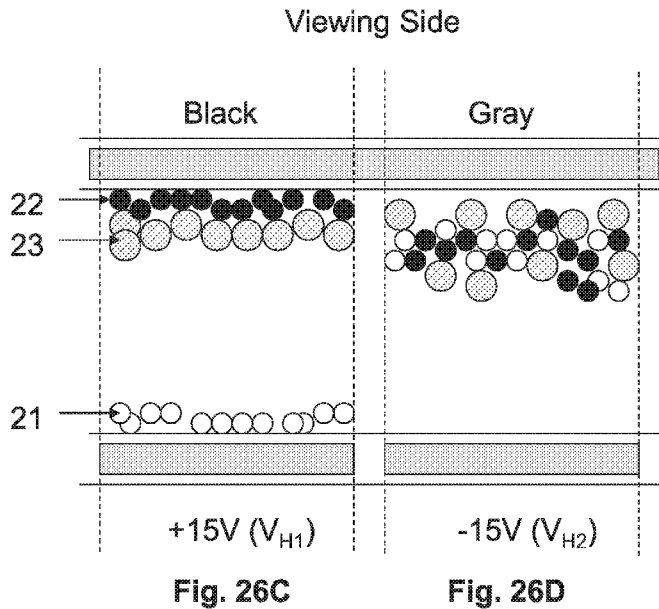

(57) Abstract: The present invention is directed to driving methods for a color display device which can display high quality color states. The display device utilizes an electrophoretic fluid which comprises three types of pigment particles having different optical characteristics, and provides for displaying at a viewing surface not only the colors of the three types of particles but also the colors of binary mixtures thereof.



WO 2018/200252 A1

**WO 2018/200252 A1** 

GM, KE, LR, LS, MW, MZ, NA, RW, SD, SL, ST, SZ, TZ, UG, ZM, ZW), Eurasian (AM, AZ, BY, KG, KZ, RU, TJ, TM), European (AL, AT, BE, BG, CH, CY, CZ, DE, DK, EE, ES, FI, FR, GB, GR, HR, HU, IE, IS, IT, LT, LU, LV, MC, MK, MT, NL, NO, PL, PT, RO, RS, SE, SI, SK, SM, TR), OAPI (BF, BJ, CF, CG, CI, CM, GA, GN, GQ, GW, KM, ML, MR, NE, SN, TD, TG).

**Declarations under Rule 4.17:**

- *as to applicant's entitlement to apply for and be granted a patent (Rule 4.17(ii))*
- *as to the applicant's entitlement to claim the priority of the earlier application (Rule 4.17(iii))*

**Published:**

- *with international search report (Art. 21(3))*
- *before the expiration of the time limit for amending the claims and to be republished in the event of receipt of amendments (Rule 48.2(h))*

# DRIVING METHODS FOR COLOR DISPLAY DEVICE

**[Para 1]**

## FIELD OF THE INVENTION

**[Para 2]** The present invention is directed to driving methods for color display devices to display high quality color states.

## BACKGROUND OF THE INVENTION

**[Para 3]** In order to achieve a color display, color filters are often used. The most common approach is to add color filters on top of black/white sub-pixels of a pixellated display to display the red, green and blue colors. When a red color is desired, the green and blue sub-pixels are turned to the black state so that the only color displayed is red. When a blue color is desired, the green and red sub-pixels are turned to the black state so that the only color displayed is blue. When a green color is desired, the red and blue sub-pixels are turned to the black state so that the only color displayed is green. When a black state is desired, all three-sub-pixels are turned to the black state. When a white state is desired, the three sub-pixels are turned to red, green and blue, respectively, and as a result, a white state is seen by the viewer.

**[Para 4]** The biggest disadvantage of such a technique is that since each of the sub-pixels has a reflectance of about one third ( $1/3$ ) of the desired white state, the white state is fairly dim. To compensate for this, a fourth sub-pixel may be added which can display only the black and white states, so that the white level is doubled at the expense of the red, green or blue color level (where each sub-pixel is only one fourth of the area of the pixel). Brighter colors can be achieved by adding light from the white pixel, but this is achieved at the expense of color gamut to cause the colors to be very light and unsaturated. A similar result can be achieved by reducing the color saturation of the three sub-pixels. Even with these approaches, the white level is normally substantially less than half of that of a black and white display, rendering it an

unacceptable choice for display devices, such as e-readers or displays that need well readable black-white brightness and contrast.

### SUMMARY OF THE INVENTION

[Para 5] A first aspect of the present invention is directed to a driving method for an electrophoretic display comprising a first surface on the viewing side, a second surface on the non-viewing side and an electrophoretic fluid which comprises a first type of pigment particles, a second type of pigment particles and a third type of pigment particles, all of which are dispersed in a liquid, wherein

- a) the three types of pigment particles have optical characteristics differing from one another;
- b) the first type of pigment particles and the second type of pigment particles carry opposite charge polarities; and
- c) the third type of pigment particles has the same charge polarity as the second type of pigment particles but a lower zeta potential,

the method comprising the following steps:

- (i) applying a first driving voltage to a pixel in the electrophoretic display for a first period of time, the first driving voltage having a polarity driving the first type of pigment particles towards the first surface, thereby causing the pixel to display the optical characteristic of the first type of pigment particles at the first surface;
- (ii) applying a second driving voltage to the pixel for a second period of time, the second driving voltage having a polarity driving the third type of pigment particles towards the first surface, thereby driving the pixel towards the optical characteristic of the third type of pigment particles at the first surface; and

repeating steps (i) and (ii).

[Para 6] In one embodiment, the first type of pigment particles is negatively charged and the second type of pigment particles is positively charged. In one embodiment, the amplitude of the second driving voltage is less than 50% of the amplitude of the first driving voltage. In one embodiment, steps (i) and (ii) are repeated at least 4 times. In one embodiment, the method further comprises a shaking waveform before step (i). In one embodiment, the method further comprises driving the pixel to the full optical characteristic of the first type of pigment particles

after the shaking waveform but prior to step (i). In one embodiment, the first period of time is 40 to 140 msec, the second period of time is greater than or equal to 460 msec and steps (i) and (ii) are repeated at least seven times.

**[Para 7]** A second aspect of the present invention is directed to a driving method for an electrophoretic display as described above but including an additional step, as follows: applying no driving voltage to the pixel for a third period of time after step (ii) but before repeating steps (i) and (ii); and repeating steps (i), (ii) and (iii).

**[Para 8]** In one embodiment, the first type of pigment particles is negatively charged and the second type of pigment particles is positively charged. In one embodiment, the amplitude of the second driving voltage is less than 50% of the amplitude of the first driving voltage. In one embodiment, steps (i), (ii) and (iii) are repeated at least 4 times. In one embodiment, the method further comprises a shaking waveform before step (i). In one embodiment, the method further comprises a driving step to the full color state of the first type of pigment particles after the shaking waveform but prior to step (i).

**[Para 9]** A third aspect of the present invention is directed to a driving method for an electrophoretic display comprising a first surface on the viewing side, a second surface on the non-viewing side and an electrophoretic fluid which comprises a first type of pigment particles, a second type of pigment particles and a third type of pigment particles, all of which are dispersed in a liquid, wherein

- a) the three types of pigment particles have optical characteristics differing from one another;
  - b) the first type of pigment particles and the second type of pigment particles carry opposite charge polarities; and
  - c) the third type of pigment particles has the same charge polarity as the second type of pigment particles a lower zeta potential,
- and the method has a voltage insensitive range of at least 0.7 V.

**[Para 10]** A fourth aspect of the present invention is directed to a driving method for an electrophoretic display as per the first aspect of the invention but including additional steps as follows:

- (iii) after step (i) but before step (ii) applying no driving voltage to the pixel for a third period of time;
- (iv) after step (ii) but before repeating the steps, applying no driving voltage to the pixel for a fourth period of time; and

repeating steps (i)-(iv).

**[Para 11]** In one embodiment, the first type of pigment particles may be negatively charged and the second type of pigment particles positively charged. In one embodiment, the amplitude of the second driving voltage is less than 50% of the amplitude of the first driving voltage. In one embodiment, steps (i)-(iv) are repeated at least 3 times. In one embodiment, the method further comprises a shaking waveform before step (i). In one embodiment, the method further comprises driving the pixel to the full color state of the first type of pigment particles after the shaking waveform but prior to step (i).

**[Para 12]** A fifth aspect of the present invention is directed to a driving method for an electrophoretic display comprising a first surface on the viewing side, a second surface on the non-viewing side and an electrophoretic fluid which fluid is sandwiched between a common electrode and a layer of pixel electrodes and comprises a first type of pigment particles, a second type of pigment particles and a third type of pigment particles, all of which are dispersed in a solvent or solvent mixture, wherein

- a) the three types of pigment particles have optical characteristics differing from one another;
- b) the first type of pigment particles and the second type of pigment particles carry opposite charge polarities; and
- c) the third type of pigment particles has the same charge polarity as the second type of pigment particles but at a lower intensity,

the method comprising the following steps:

- (i) applying a first driving voltage to a pixel in the electrophoretic display for a first period of time, wherein the first driving voltage has the same polarity as the first type of pigment particles to drive the pixel towards the color state of the first type of pigment particles at the viewing side;
- (ii) applying a second driving voltage to the pixel for a second period of time, wherein the second driving voltage has the same polarity as the second type of pigment particles to drive the pixel towards the color state of the second type of pigment particles at the viewing side; and

repeating steps (i) and (ii).

**[Para 13]** In one embodiment, the method further comprises a wait time where no driving voltage is applied. In one embodiment, the first type of pigment particles is negatively charged and the second type of pigment particles is positively charged. In one embodiment, the second

period of time is at least twice as long as the first period of time. In one embodiment, steps (i) and (ii) are repeated for least three times. In one embodiment, the method further comprises a shaking waveform before step (i). In one embodiment, the method further comprises driving the pixel to the full color state of the second type of pigment particles after the shaking waveform but prior to step (i).

**[Para 14]** A sixth aspect of the present invention is directed to a driving method for an electrophoretic display comprising a first surface on the viewing side, a second surface on the non-viewing side and an electrophoretic fluid which fluid is sandwiched between a common electrode and a layer of pixel electrodes and comprises a first type of pigment particles, a second type of pigment particles and a third type of pigment particles, all of which are dispersed in a solvent or solvent mixture, wherein

- a) the three types of pigment particles have optical characteristics differing from one another;
- b) the first type of pigment particles and the second type of pigment particles carry opposite charge polarities; and
- c) the third type of pigment particles has the same charge polarity as the second type of pigment particles but at a lower intensity,

the method comprising the following steps:

- (i) applying a first driving voltage to a pixel in the electrophoretic display for a first period of time, wherein the first driving voltage has the same polarity as the second type of pigment particles to drive the pixel towards the color state of the second type of pigment particles at the viewing side;
- (ii) applying a second driving voltage to the pixel for a second period of time, wherein the second driving voltage has the same polarity as the first type of pigment particles to drive the pixel towards the color state of the first type of pigment particles at the viewing side;
- (iii) applying no driving voltage to the pixel for a third period of time; and repeating steps (i), (ii) and (iii).

**[Para 15]** In one embodiment, the first type of pigment particles is negatively charged and the second type of pigment particles is positively charged. In one embodiment, steps (i), (ii) and (iii) are repeated at least three times. In one embodiment, the amplitude of the second driving voltage is same as that of the driving voltage required to drive the pixel from the color state of the first type of pigment particles to the color state of the second type of pigment particles, or

*vice versa*. In one embodiment, the amplitude of the second driving voltage is higher than the amplitude of the driving voltage required to drive the pixel from the color state of the first type of pigment particles to the color state of the second type of pigment particles, or *vice versa*. In one embodiment, the method further comprises a shaking waveform. In one embodiment, the method further comprises driving the pixel to the full color state of the first type of pigment particles after the shaking waveform but prior to step (i).

**[Para 16]** A seventh aspect of the present invention is directed to a driving method for an electrophoretic display comprising a first surface on the viewing side, a second surface on the non-viewing side and an electrophoretic fluid which fluid is sandwiched between a common electrode and a layer of pixel electrodes and comprises a first type of pigment particles, a second type of pigment particles and a third type of pigment particles, all of which are dispersed in a solvent or solvent mixture, wherein

- a) the three types of pigment particles have optical characteristics differing from one another;
- b) the first type of pigment particles and the second type of pigment particles carry opposite charge polarities; and
- c) the third type of pigment particles has the same charge polarity as the second type of pigment particles but at a lower intensity,

the method comprising the following steps:

- (i) applying a first driving voltage to a pixel in the electrophoretic display for a first period of time, which first driving voltage has the same polarity as the second type of pigment particles to drive the pixel towards the color state of the second type of pigment particles wherein the first period of time is not sufficient to drive the pixel to the full color state of the second type of pigment particles at the viewing side;
  - (ii) applying a second driving voltage to the pixel for a second period of time, which second driving voltage has the same polarity as the first type of pigment particles to drive the pixel towards a mixed state of the first and second types of pigment particles at the viewing side; and
- repeating steps (i) and (ii).

**[Para 17]** In one embodiment, the first type of pigment particles is negatively charged and the second type of pigment particles is positively charged. In one embodiment, the amplitude of the second driving voltage is less than 50% of the amplitude of the first driving voltage. In one

embodiment, steps (i) and (ii) are repeated at least 4 times. In one embodiment, the method further comprises a shaking waveform before step (i). In one embodiment, the method further comprises driving the pixel to the full color state of the first type of pigment particles after the shaking waveform but prior to step (i).

**[Para 18]** The fourth driving method of the present invention may be applied to a pixel at a color state of the first type of pigment particles or may be applied to a pixel at a color state not the color state of the first type of pigment particles.

**[Para 19]** This invention also provides driving methods to display mixtures of the optical characteristics of two of the three particles in electrophoretic display fluids as previously described. A first such “mixed characteristic” method comprises the following steps:

- (i) applying a first driving voltage to a pixel in the electrophoretic display for a first period of time, the first driving voltage having a polarity driving the first type of pigment particles towards the first surface, thereby causing the pixel to display the optical characteristic of the first type of pigment particles at the first surface;
- (ii) applying a second driving voltage to the pixel for a second period of time, the second driving voltage having a polarity driving the third type of pigment particles towards the first surface, thereby driving the pixel towards the optical characteristic of the third type of pigment particles at the first surface; and
- (iii) applying a third driving voltage for a third period of time, the third driving voltage having the same polarity as the first driving voltage, and the third period of time being shorter than the first period of time, thereby producing a mixture of the optical characteristics of the first and third types of particles at the viewing surface.

**[Para 20]** In this first mixed characteristic method the duration of the third period of time may be from about 20 to about 80 per cent, and preferably from about 20 to about 40 per cent, of the duration of the first period of time. A shaking waveform may be applied prior to step (i), and a driving voltage driving the first type of pigment particles towards the first surface may be applied prior to the shaking waveform.

**[Para 21]** A second “mixed characteristic” method comprises the following steps:

- (i) applying a first driving voltage to a pixel in the electrophoretic display for a first period of time, the first driving voltage having a polarity driving the

second type of pigment particles towards the first surface, thereby causing the pixel to display the optical characteristic of the second type of pigment particles at the first surface;

- (ii) applying a second driving voltage to the pixel for a second period of time, the second driving voltage having the same polarity as, but a lower magnitude than the first driving voltage, thereby driving the third type of pigment particles at the first surface, and producing a mixture of the optical characteristics of the second and third types of particles at the first surface.

**[Para 22]** In this second mixed characteristic method, the duration of the second period of time may be from about 100 to about 150 per cent of the duration of the first period of time. A shaking waveform may be applied prior to step (i), and a driving voltage driving the first type of pigment particles towards the first surface may be applied prior to the shaking waveform.

**[Para 23]** A third “mixed characteristic” method comprises the following steps:

- (i) applying a first driving voltage to a pixel in the electrophoretic display for a first period of time, the first driving voltage having a polarity driving the first type of pigment particles towards the first surface, thereby causing the pixel to display the optical characteristic of the first type of pigment particles at the first surface;
- (ii) applying a second driving voltage to the pixel for a second period of time, the second driving voltage having a polarity driving the third type of pigment particles towards the first surface; and

repeating steps (i) and (ii),

wherein the durations of steps (i) and (ii) and the magnitudes of the voltages applied therein are adjusted to produce a mixture of the optical characteristics of the third type of particles with one of the first and second types of particles at the first surface.

**[Para 24]** In this third mixed characteristic method, a shaking waveform may be applied prior to step (i), and a driving voltage driving the first type of pigment particles towards the first surface may be applied prior to the shaking waveform.

**[Para 24a]** In an aspect, there is provided a driving method for an electrophoretic display comprising a first surface on the viewing side, a second surface on the non-viewing side and an electrophoretic fluid which comprises a first type of pigment particles, a second type of pigment particles and a third type of pigment particles, all of which are dispersed in a liquid, wherein

- a) the three types of pigment particles have optical characteristics differing from one another;
- b) the first type of pigment particles and the second type of pigment particles carry opposite charge polarities; and
- c) the third type of pigment particles has the same charge polarity as the second type of pigment particles but a lower zeta potential,

the method comprising the following steps:

- (i) applying a first driving voltage to a pixel in the electrophoretic display for a first period of time, the first driving voltage having a polarity driving the first type of pigment particles towards the first surface, thereby causing the pixel to display the optical characteristic of the first type of pigment particles at the first surface;
- (ii) applying a second driving voltage to the pixel for a second period of time, the second driving voltage having a polarity driving the third type of pigment particles towards the first surface, thereby driving the pixel towards the optical characteristic of the third type of pigment particles at the first surface; and
- (iii) applying a third driving voltage for a third period of time, the third driving voltage having the same polarity as the first driving voltage, and the third period of time being shorter than the first period of time, thereby producing a mixture of the optical characteristics of the first and third types of pigment particles at the viewing surface.

**[Para 24b]** In another aspect, there is provided a driving method for an electrophoretic display comprising a first surface on the viewing side, a second surface on the non-viewing side and an electrophoretic fluid which comprises a first type of pigment particles, a second type of pigment particles and a third type of pigment particles, all of which are dispersed in a liquid, wherein

- a) the three types of pigment particles have optical characteristics differing from one another;
- b) the first type of pigment particles and the second type of pigment particles carry opposite charge polarities; and
- c) the third type of pigment particles has the same charge polarity as the second type of pigment particles but a lower zeta potential,

the method comprising the following steps:

- (i) applying a first driving voltage to a pixel in the electrophoretic display for a first period of time, the first driving voltage having a polarity driving the second type of pigment particles towards the first surface, thereby causing the pixel to display the optical characteristic of the second type of pigment particles at the first surface; and
- (ii) applying a second driving voltage to the pixel for a second period of time, the second driving voltage having the same polarity as, but a lower magnitude than the first driving voltage, thereby driving the third type of pigment particles at the first surface, and producing a mixture of the optical characteristics of the second and third types of pigment particles at the first surface.

### **BRIEF DESCRIPTION OF THE DRAWINGS**

**[Para 25]** FIG. 1 is a schematic cross-section through an electrophoretic display fluid useful in the driving methods of the present invention.

[Para 26] FIGS. 2A, 2B and 2C are schematic cross-sections, similar to that of FIG. 1, showing the positions of the particles in, respectively, the black, white and red (colored) states of the display fluid.

[Para 27] FIG. 3 illustrates a typical waveform for driving a pixel from the white state of FIG. 2B to the red state of FIG. 2C.

[Para 28] FIG. 4 illustrates a waveform that may be used to replace the portion of the waveform of FIG. 3 in period  $t_3$  to effect the first driving method of the present invention.

[Para 29] FIGS. 5 and 6 depict waveforms produced by modifying the waveform of FIG. 3 with the partial waveform of FIG. 4 to effect the first driving method of the present invention.

[Para 30] FIG. 7 illustrates a second waveform which may be used to replace the portion of the waveform of FIG. 3 in period  $t_3$  to effect the second driving method of the present invention.

[Para 31] FIGS. 8 and 9 depict waveforms produced by modifying the waveform of FIG. 3 with the partial waveform of FIG. 7 to effect the second driving method of the present invention.

[Para 32] FIGS. 10A and 10B illustrate the optical results produced by the third driving method of the present invention. FIG. 10A demonstrates the relationship of applied driving voltage vs. optical state performance ( $a^*$ ), based on the waveform of FIG. 3, and FIG. 10B demonstrates the relationship of applied driving voltage vs. optical state performance ( $a^*$ ), based on the waveform of FIG. 3 modified with the partial waveform of FIG. 4.

[Para 33] FIG. 11 illustrates a waveform which may be used to replace the portion of the waveform of FIG. 3 in period  $t_3$  to effect the fourth driving method of the present invention.

[Para 34] FIGS. 12 and 13 depict waveforms produced by modifying the waveform of FIG. 3 with the partial waveform of FIG. 11 to effect the fourth driving method of the present invention.

[Para 35] FIG. 14 depicts a typical waveform for driving a pixel from the white state of FIG. 2B to the black state of FIG. 2A.

[Para 36] FIG. 15 illustrates a waveform which may be added at the end of the waveform of FIG. 14 to effect the fifth driving method of the present invention.

[Para 37] FIG. 16 illustrates a complex waveform combining the waveforms of FIGS. 14 and 15 to effect the fifth driving method of the present invention.

[Para 38] FIG. 17 depicts a typical waveform for driving a pixel to the white state of FIG. 2B.

[Para 39] FIGS. 18A and 18B illustrate two waveforms which may be used to replace the portion of the waveform of FIG. 17 in period t17 to effect the sixth driving method of the present invention.

[Para 40] FIGS. 19A and 19B depict waveforms produced by modifying the waveform of FIG. 17 with the partial waveform of FIG. 18A or 18B respectively to effect the sixth driving method of the present invention.

[Para 41] FIGS. 20A and 20B are schematic cross-sections, similar to that of FIG. 1, showing the positions of the particles in, respectively, the black and grey states of the display fluid.

[Para 42] FIG. 21 illustrates a typical waveform for driving a pixel to the grey state of FIG. 20B.

[Para 43] FIG. 22 illustrates a waveform which may be used to replace the portion of the waveform of FIG. 21 in period t23 to effect the seventh driving method of the present invention.

[Para 44] FIG. 23 illustrates a complex waveform combining the waveforms of FIGS. 21 and 22 to effect the seventh driving method of the present invention.

[Para 45] FIG. 24 illustrates a waveform used in the eighth driving method of the present invention.

[Para 46] FIG. 25 illustrates a complex waveform combining the waveforms of FIGS. 14 and 24 to effect the eighth driving method of the present invention.

[Para 47] FIGS. 26A and 26B illustrate production of a gray state of a pixel beginning from the white state thereof.

[Para 48] FIGS. 26C and 26D illustrate production of a gray state of a pixel beginning from the black state thereof.

[Para 49] FIG.27 illustrates a waveform useful to drive the display to a light red state via a white state in the first mixed characteristic driving method of the present invention.

[Para 50] FIG. 28 illustrates a waveform useful to drive the display to a dark red state in the second mixed characteristic driving method of the present invention.

[Para 51] FIG. 29 illustrates a second waveform useful to drive the display to a dark red state in the third mixed characteristic driving method of the present invention.

## **DETAILED DESCRIPTION OF THE INVENTION**

[Para 52] The present invention is directed to driving methods for color display devices.

[Para 53] The device utilizes an electrophoretic fluid as shown in FIG. 1. The fluid comprises three types of pigment particles dispersed in a liquid, typically a dielectric solvent or solvent

mixture. For ease of illustration, the three types of pigment particles may be referred to as white particles (11), black particles (12) and colored particles (13). The colored particles are non-white and non-black.

**[Para 54]** However, it is understood that the scope of the invention broadly encompasses pigment particles of any colors as long as the three types of pigment particles have distinguishable optical characteristics. Therefore, the three types of pigment particles may also be referred to as a first type of pigment particles, a second type of pigment particles and a third type of pigment particles.

**[Para 55]** The white particles (11) may be formed from an inorganic pigment, such as TiO<sub>2</sub>, ZrO<sub>2</sub>, ZnO, Al<sub>2</sub>O<sub>3</sub>, Sb<sub>2</sub>O<sub>3</sub>, BaSO<sub>4</sub>, PbSO<sub>4</sub> or the like.

**[Para 56]** The black particles (12) may be CI pigment black 26 or 28 or the like (e.g., manganese ferrite black spinel or copper chromite black spinel) or carbon black.

**[Para 57]** The third type of particles may be of a color such as red, green, blue, magenta, cyan or yellow. The pigments for this type of particles may include, but are not limited to, CI pigment PR 254, PR122, PR149, PG36, PG58, PG7, PB15:3, PY138, PY150, PY155 or PY20. Those are commonly used organic pigments described in color index handbooks, "New Pigment Application Technology" (CMC Publishing Co, Ltd, 1986) and "Printing Ink Technology" (CMC Publishing Co, Ltd, 1984). Specific examples include Clariant Hostaperm Red D3G 70-EDS, Hostaperm Pink E-EDS, PV fast red D3G, Hostaperm red D3G 70, Hostaperm Blue B2G-EDS, Hostaperm Yellow H4G-EDS, Hostaperm Green GNX, BASF Irgazine red L 3630, Cinquasia Red L 4100 HD, and Irgazine Red L 3660 HD; Sun Chemical phthalocyanine blue, phthalocyanine green, diarylide yellow or diarylide AAOT yellow.

**[Para 58]** In addition to colors, the first, second and third types of particles may have other distinct optical characteristics, such as optical transmission, reflectance, luminescence or, in the case of displays intended for machine reading, pseudo-color in the sense of a change in reflectance of electromagnetic wavelengths outside the visible range.

**[Para 59]** The liquid in which the three types of pigment particles are dispersed may be clear and colorless. It preferably has a low viscosity and a dielectric constant in the range of about 2 to about 30, preferably about 2 to about 15 for high particle mobility. Examples of suitable dielectric fluids include hydrocarbons such as Isopar, decahydronaphthalene (DECALIN), 5-ethylidene-2-norbornene, fatty oils, paraffin oil, silicon fluids, aromatic hydrocarbons such as toluene, xylene, phenylxylylene, dodecylbenzene or alkyl naphthalene, halogenated solvents such as perfluorodecalin, perfluorotoluene, perfluoroxylene, dichlorobenzotrifluoride,

3,4,5-trichlorobenzotrifluoride, chloropentafluorobenzene, dichlorononane or pentachlorobenzene, and perfluorinated solvents such as FC-43, FC-70 or FC-5060 from 3M Company, St. Paul MN, low molecular weight halogen containing polymers such as poly(perfluoropropylene oxide) from TCI America, Portland, Oregon, poly(chlorotrifluoroethylene) such as Halocarbon Oils from Halocarbon Product Corp., River Edge, NJ, perfluoropolyalkylether such as Galden from Ausimont or Krytox Oils and Greases K-Fluid Series from DuPont, Delaware, polydimethylsiloxane based silicone oil from Dow-corning (DC -200).

**[Para 60]** A display layer utilizing the display fluid of the present invention has two surfaces, a first surface (16) on the viewing side and a second surface (17) on the opposite side of the layer of display fluid from the first surface (16). The second surface therefore is on the non-viewing side. The term “viewing side” refers to the side at which images are viewed.

**[Para 61]** The display fluid is sandwiched between the two surfaces. On the side of the first surface (16), there is a common electrode (14) which is a transparent electrode layer (e.g., ITO), spreading over the entire top of the display layer. On the side of the second surface (17), there is an electrode layer (15) which comprises a plurality of pixel electrodes (15a). However, since, as will readily be apparent to those skilled in the technology of electrophoretic displays, the various particles (11, 12, 13) react only to the electric field applied within the layer of display fluid, other electrode arrangements may be used; for example, the common electrode could be replaced by a series of strip electrodes, or by a matrix of electrodes similar to the pixel electrodes 15a.

**[Para 62]** The display fluid is filled in display cells. The display cells may be aligned with or not aligned with the pixel electrodes. The term “display cell” refers a micro-container which is filled with an electrophoretic fluid. Examples of “display cells” may include the cup-like microcells as described in U.S. Pat. No. 6,930,818 and microcapsules as described in U.S. Pat. No. 5,930,026. The micro-containers may be of any shapes or sizes, all of which are within the scope of the present application.

**[Para 63]** An area corresponding to a pixel electrode may be referred to as a pixel (or a sub-pixel). The driving of an area corresponding to a pixel electrode is effected by applying a voltage potential difference (or known as a driving voltage or an electric field) between the common electrode and the pixel electrode.

**[Para 64]** The pixel electrodes are described in U.S. Pat. No. 7,046,228. It is noted that while active matrix driving

with a thin film transistor (TFT) backplane is mentioned for the layer of pixel electrodes, the scope of the present invention encompasses other types of electrode addressing as long as the electrodes serve the desired functions.

**[Para 65]** The space between two vertical dotted lines denotes a pixel (or a sub-pixel). For brevity, when “pixel” is referred to in a driving method, the term also encompasses “sub-pixels”.

**[Para 66]** Two of the three types of pigment particles carry opposite charge polarities and the third type of pigment particles is slightly charged. The term “slightly charged” or “lower charge intensity” is intended to refer to the charge level of the particles being less than about 50%, preferably about 5% to about 30%, the charge intensity of the stronger charged particles. In one embodiment, the charge intensity may be measured in terms of zeta potential. In one embodiment, the zeta potential is determined by Colloidal Dynamics AcoustoSizer IIM with a CSPU-100 signal processing unit, ESA EN# Attn flow through cell (K:127). The instrument constants, such as density of the solvent used in the sample, dielectric constant of the solvent, speed of sound in the solvent, viscosity of the solvent, all of which at the testing temperature (25° C.) are entered before testing. Pigment samples are dispersed in the solvent (which is usually a hydrocarbon fluid having less than 12 carbon atoms), and diluted to between 5-10% by weight. The sample also contains a charge control agent (Solsperse 17000, available from Lubrizol Corporation, a Berkshire Hathaway company; “Solsperse” is a Registered Trade Mark), with a weight ratio of 1:10 of the charge control agent to the particles. The mass of the diluted sample is determined and the sample is then loaded into the flow through cell for determination of the zeta potential.

**[Para 67]** For example, if the black particles are positively charged and the white particles are negatively charged, and then the colored pigment particles may be slightly charged. In other words, in this example, the charges carried by the black and the white particles are much more intense than the charge carried by the colored particles.

**[Para 68]** In addition, the colored particles which carries a slight charge has a charge polarity which is the same as the charge polarity carried by either one of the other two types of the stronger charged particles. Hereinafter, it will be assumed that the colored particles (13) carry a charge of the same polarity as the second (black) particles (12).

**[Para 69]** It is noted that among the three types of pigment particles, the one type of particles which is slightly charged preferably has a larger size.

[Para 70] In addition, in the context of the present application, a high driving voltage ( $V_{H1}$  or  $V_{H2}$ ) is defined as a driving voltage which is sufficient to drive a pixel from one extreme color state to another extreme color state. If the first and the second types of pigment particles are the higher charged particles, a high driving voltage then ( $V_{H1}$  or  $V_{H2}$ ) refers a driving voltage which is sufficient to drive a pixel from the color state of the first type of pigment particles to the color state of the second type of pigment particles, or *vice versa*. For example, a high driving voltage,  $V_{H1}$ , refers to a driving voltage which is sufficient to drive a pixel from the color state of the first type of pigment particles to the color state of the second type of pigment particles, and  $V_{H2}$  refers to a driving voltage which is sufficient to drive a pixel from the color state of the second type of pigment particles to the color state of the first type of pigment particles. In this scenario as described, a low driving voltage ( $V_L$ ) is defined as a driving voltage which may be sufficient to drive a pixel to the color state of the third type of pigment particles (which are less charged and may be larger in size) from the color state of the first type of pigment particles. For example, a low driving voltage may be sufficient to drive to the color state of the colored particles while the black and white particles are not seen at the viewing side.

[Para 71] In general, the  $V_L$  is less than 50%, or preferably less than 40%, of the amplitude of  $V_H$  (e.g.,  $V_{H1}$  or  $V_{H2}$ ).

[Para 72] The following is an example illustrating a driving scheme of how different color states may be displayed by an electrophoretic fluid as described above.

### Example 1

[Para 73] This example is demonstrated in FIGS. 2A-2C. The white pigment particles (21) are negatively charged while the black pigment particles (22) are positively charged, and both types of the pigment particles are smaller than the colored particles (23).

[Para 74] The colored particles (23) carry the same charge polarity as the black particles, but are slightly charged. As a result, the black particles move faster than the colored particles (23) under certain driving voltages.

[Para 75] In FIG. 2A, the applied driving voltage is +15V (i.e.,  $V_{H1}$ , i.e., the pixel electrode is at +15 V relative to the common electrode). In this case, the negative white particles (21) move to be near or at the relatively positive pixel electrode (25) and the positive black particles (22) and the positive colored particles (23) move to be near or at the relatively negative common electrode (24). As a result, the black color is seen at the viewing side. The colored particles (23) move towards the common electrode (24) at the viewing side; however because their lower charge intensity and larger size, they move slower than the black particles.

[Para 76] In FIG. 2B, when a driving voltage of  $-15\text{V}$  (i.e.,  $V_{H2}$ ) is applied, the negative white particles (21) move to be near or at the relatively positive common electrode (24) at the viewing side and the positive black particles and the positive colored particles move to be near or at the relatively negative pixel electrode (25). As a result, the white color is seen at the viewing side.

[Para 77] It is noted that  $V_{H1}$  and  $V_{H2}$  have opposite polarities, and have the same amplitude or different amplitudes. In the example as shown in FIG. 2,  $V_{H1}$  is positive (the same polarity as the black particles) and  $V_{H2}$  is negative (the same polarity as the white particles)

[Para 78] The driving from the white color state in FIG. 2B to the colored state in FIG. 2C may be summarized as follows:

[Para 79] A driving method for an electrophoretic display comprising a first surface on the viewing side, a second surface on the non-viewing side and an electrophoretic fluid which fluid is sandwiched between a common electrode and a layer of pixel electrodes and comprises a first type of pigment particles (i.e., white), a second type of pigment particles (i.e., black) and a third type of pigment particles (i.e., colored), all of which are dispersed in a solvent or solvent mixture, wherein

- a) the three types of pigment particles have optical characteristics differing from one another;
- b) the first type of pigment particles and the second type of pigment particles carry opposite charge polarities; and
- c) the third type of pigment particles has the same charge polarity as the second type of pigment particles but at a lower intensity,

which method comprises driving a pixel in the electrophoretic display from the color state of the first type of pigment particles towards the color state of the third type of pigment particles by applying a low driving voltage which is sufficient to drive the third type of pigment particles to the viewing side while leaving the first and second types of pigment particles on the non-viewing side and the polarity of the low driving voltage applied is the same as the polarity of the third type of pigment particles.

[Para 80] In order to drive a pixel to the color state of the third type of pigment particles, i.e., red (see FIG. 2C), the method starts from the color state of the first type of pigment particles, i.e., white (see FIG. 2B).

[Para 81] When the color of the third type of particles is seen at the viewing side, the other two types of the particles may be mixed at the non-viewing side (side opposite of the viewing side), resulting in an intermediate color state between the colors of the first and second types

of particles. If the first and second types of particles are black and white and the third type of particles is red, then in FIG. 2C, when the red color is seen at the viewing side, a grey color is at the non-viewing side.

**[Para 82]** The driving method ideally would ensure both color brightness (i.e., preventing the black particles from being seen) and color purity (i.e., preventing the white particles from being seen) in the scenario of FIG. 2C. However, in practice, this desired result is difficult to achieve for various reasons, including particle size distribution and particle charge distribution.

**[Para 83]** One solution to this is the use of a shaking waveform prior to driving from the color state of the first type of pigment particles (i.e., white) to the color state of the third type of pigment particles (i.e., red). The shaking waveform consists of repeating a pair of opposite driving pulses for many cycles. For example, the shaking waveform may consist of a +15V pulse for 20 msec and a -15V pulse for 20 msec and such a pair of pulses is repeated for 50 times. The total time of such a shaking waveform would be 2000 msec. The notation, "msec", stands for millisecond.

**[Para 84]** The shaking waveform may be applied to a pixel regardless of the optical state (black, white or red) prior to a driving voltage being applied. After the shaking waveform is applied, the optical state would not be a pure white, pure black or pure red. Instead, the color state would be from a mixture of the three types of pigment particles.

**[Para 85]** For the method as described above, a shaking waveform is applied prior to the pixel being driven to the color state of the first type of pigment particles (i.e., white). With this added shaking waveform, even though the white state is measurably the same as that without the shaking waveform, the color state of the third type of pigment particles (i.e., red) would be significantly better than that without the shaking waveform, on both color brightness and color purity. This is an indication of better separation of the white particles from the red particles as well as better separation of the black particles from the red particles.

**[Para 86]** Each of the driving pulses in the shaking waveform is applied for not exceeding half of the driving time required for driving from the full black state to the full white state, or vice versa. For example, if it takes 300 msec to drive a pixel from a full black state to a full white state, or vice versa, the shaking waveform may consist of positive and negative pulses, each applied for not more than 150 msec. In practice, it is preferred that the shaking waveform pulses are shorter.

**[Para 87]** It is noted that in all of the drawings throughout this application, the shaking waveform is truncated (i.e., the number of pulses is fewer than the actual number).

[Para 88] The waveform used to drive the display to the colored (red) state of FIG. 2C is shown in FIG. 3. In this waveform, a high negative driving voltage ( $V_{H2}$ , e.g.,  $-15V$ ) is applied for a period of  $t_2$ , to drive a pixel towards a white state after a shaking waveform. From the white state, the pixel may be driven towards the colored state (i.e., red) by applying a low positive voltage ( $V_L$ , e.g.,  $+5V$ ) for a period of  $t_3$  (that is, driving the pixel from FIG. 2B to FIG. 2C).

[Para 89] The driving period “ $t_2$ ” is a time period sufficient to drive a pixel to the white state when  $V_{H2}$  is applied and the driving period “ $t_3$ ” is a time period sufficient to drive the pixel to the red state from the white state when  $V_L$  is applied. A driving voltage is preferably applied for a period of  $t_1$  before the shaking waveform to ensure DC balance. The term “DC balance”, throughout this application, is intended to mean that the driving voltages applied to a pixel is substantially zero when integrated over a period of time (e.g., the period of an entire waveform).

**The First Driving Method:**

[Para 90] A waveform useful in the first driving method of the present invention is illustrated in FIG. 4; this waveform may be used to replace the driving period of  $t_3$  in FIG. 3.

[Para 91] In an initial step, a high negative driving voltage ( $V_{H2}$ , e.g.,  $-15V$ ) is applied, which is followed by a positive driving voltage ( $+V'$ ) to drive a pixel towards the red state. The amplitude of the  $+V'$  is less than 50% of the amplitude of  $V_H$  (e.g.,  $V_{H1}$  or  $V_{H2}$ ).

[Para 92] In this driving waveform, a high negative driving voltage ( $V_{H2}$ ) is applied for a period of  $t_4$  to push the white particles towards the viewing side, which is then followed by applying a positive driving voltage of  $+V'$  for a period of  $t_5$ , which pulls the white particles down and pushes the red particles towards the viewing side.

[Para 93] In one embodiment,  $t_4$  may be in the range of 20-400 msec and  $t_5$  may be  $\geq 200$  msec.

[Para 94] The waveform of FIG. 4 is repeated for at least 4 cycles ( $N \geq 4$ ), preferably at least 8 cycles. The red color becomes more intense after each driving cycle.

[Para 95] The driving method of FIG. 4 may be summarized as follows:

[Para 96] A driving method for an electrophoretic display comprising a first surface on the viewing side, a second surface on the non-viewing side and an electrophoretic fluid which fluid is sandwiched between a common electrode and a layer of pixel electrodes and comprises a first type of pigment particles, a second type of pigment particles and a third type of pigment particles, all of which are dispersed in a solvent or solvent mixture, wherein

- a) the three types of pigment particles have optical characteristics differing from one another;
- b) the first type of pigment particles and the second type of pigment particles carry opposite charge polarities; and
- c) the third type of pigment particles has the same charge polarity as the second type of pigment particles but at a lower intensity,

which method comprises the following steps:

- (i) applying a first driving voltage to a pixel in the electrophoretic display for a first period of time, which first driving voltage has the same polarity as the first type of pigment particles to drive the pixel towards the color state of the first type of pigment particles at the viewing side;
  - (ii) applying a second driving voltage to the pixel for a second period of time, which second driving voltage has the same polarity as the third type of pigment particles to drive the pixel towards the color state of the third type of pigment particles at the viewing side; and
- repeating steps (i) and (ii).

[Para 97] In one embodiment, the first type of pigment particles is negatively charged and the second type of pigment particles is positively charged.

[Para 98] In one embodiment, the amplitude of the second driving voltage is less than 50% of the amplitude of the first driving voltage.

[Para 99] As stated, the driving waveform as shown in FIG. 4 may be used to replace the driving period of  $t_3$  in FIG. 3, and FIG. 5 illustrates the combined waveform after this replacement. In other words, the driving sequence may be: shaking waveform, followed by driving towards the white state for a period of  $t_2$  and then applying the waveform of FIG. 4.

[Para 100] In another embodiment, the step of driving to the white state for a period of  $t_2$  may be eliminated and in this case, a shaking waveform is applied immediately before applying the waveform of FIG. 4 (see FIG. 6).

[Para 101] In one embodiment, the driving sequence of FIG. 5 or FIG. 6 is DC balanced.

#### **The Second Driving Method:**

[Para 102] A waveform useful in the second driving method of the present invention is illustrated in FIG. 7. This waveform is an alternative to the driving waveform of FIG. 4, and may also be used to replace the driving period of  $t_3$  in FIG. 3.

[Para 103] In this alternative waveform, there is a wait time “t6” added after the red-going pulse in period t5 and before the white-going pulse in period t4 and the red-going-pulse in period t5 are repeated. During the wait time, no driving voltage is applied. The entire waveform of FIG. 7 is also repeated for multiple cycles (for example,  $N \geq 4$ ).

[Para 104] The waveform of FIG. 7 is designed to release the charge imbalance stored in the dielectric layers in an electrophoretic display device, especially when the resistance of the dielectric layers is high, for example, at a low temperature.

[Para 105] In the context of the present application, the term “low temperature” refers to a temperature below about 10°C.

[Para 106] The wait time presumably can dissipate the unwanted charge stored in the dielectric layers and cause the short pulse (“t4”) for driving a pixel towards the white state and the longer pulse (“t5”) for driving the pixel towards the red state to be more efficient. As a result, this alternative driving method will bring a better separation of the low charged pigment particles from the higher charged ones. The wait time (“t6”) can be in a range of 5-5,000 msec, depending on the resistance of the dielectric layers.

[Para 107] This driving method of FIG. 7 may be summarized as follows:

[Para 108] A driving method for an electrophoretic display comprising a first surface on the viewing side, a second surface on the non-viewing side and an electrophoretic fluid which fluid is sandwiched between a common electrode and a layer of pixel electrodes and comprises a first type of pigment particles, a second type of pigment particles and a third type of pigment particles, all of which are dispersed in a solvent or solvent mixture, wherein

- a) the three types of pigment particles have optical characteristics differing from one another;
- b) the first type of pigment particles and the second type of pigment particles carry opposite charge polarities; and
- c) the third type of pigment particles has the same charge polarity as the second type of pigment particles but at a lower intensity,

which method comprises the following steps:

- (i) applying a first driving voltage to a pixel in the electrophoretic display for a first period of time, which first driving voltage has the same polarity as the first type of pigment particles to drive the pixel towards the color state of the first type of pigment particles at the viewing side;

(ii) applying a second driving voltage to the pixel for a second period of time, which second driving voltage has the same polarity as the third type of pigment particles to drive the pixel towards the color state of the third type of pigment particles at the viewing side;

(iii) applying no driving voltage to the pixel for a third period of time; and

repeating steps (i), (ii) and (iii).

[Para 109] In one embodiment, the first type of pigment particles is negatively charged and the second type of pigment particles is positively charged.

[Para 110] In one embodiment, the amplitude of the second driving voltage is less than 50% of the amplitude of the first driving voltage.

[Para 111] As stated, the driving waveform shown in FIG. 7 may also be used to replace the driving period of  $t_3$  in FIG. 3 (see FIG. 8). In other words, the driving sequence may be: shaking waveform, followed by driving towards the white state for a period of  $t_2$  and then applying the waveform of FIG. 7.

[Para 112] In another embodiment, the step of driving to the white state for a period of  $t_2$  may be eliminated and in this case, a shaking waveform is applied before applying the waveform of FIG. 7 (see FIG. 9).

[Para 113] In another embodiment, the driving sequence of FIG. 8 or FIG. 9 is DC balanced.

[Para 114] It should be noted that the lengths of any of the driving periods referred to in this application may be temperature dependent.

#### **The Third Driving Method:**

[Para 115] FIG. 10A demonstrates the relationship between applied driving voltage ( $V'$ ) and the optical performance, based on the waveform of FIG. 3. As shown, the positive driving voltage  $V'$  applied may impact on the red state performance of a color display device described above. The red state performance of the display device is expressed as  $a^*$  value, utilizing the  $L^*a^*b^*$  color system.

[Para 116] The maximum  $a^*$  in FIG. 10A appears at the applied driving voltage  $V'$ , in FIG. 3, being about 3.8V. However, if a change of  $\pm 0.5V$  is made to the applied driving voltage, the resulting  $a^*$  value would be about 37 which is roughly 90% of the maximum  $a^*$ , thus still acceptable. This tolerance can be beneficial to accommodate changing of the driving voltages caused by, for example, variation in the electronic components of a display device, the drop of battery voltage over time, batch variation of the TFT backplanes, batch variation of the display devices or temperature and humidity fluctuations.

[Para 117]Based on the data given in FIG. 10A, a study was performed to find a range of driving voltages  $V'$  that can drive to the red state with an over 90% of the maximum  $a^*$  value. In other words, when any of the driving voltages in the range is applied, the optical performance is not significantly affected. Therefore, the range may be referred to as “voltage-insensitive” range”. The wider the “voltage insensitive” range, the more tolerant the driving method is to batch variations and environmental changes.

[Para 118]In FIG. 4, there are three parameters which need to be considered for this study,  $t_4$ ,  $t_5$  and  $N$ . The effects of the three parameters on the voltage-insensitive range are interactive and non-linear.

[Para 119]Following the model of FIG. 10A, one can find the optimum value sets for the three parameters to achieve the widest voltage-insensitive range for the waveform of FIG. 4. The results are summarized in FIG. 10B.

[Para 120]When  $t_4$  is between 40-140 msec,  $t_5$  is greater than or equal to 460 msec and  $N$  is greater than or equal to 7, the voltage-insensitive range (i.e., 3.7V to 6.5V) based on FIG. 10B is twice the width of the voltage-insensitive range (i.e., 3.3V-4.7V) based on FIG. 10A.

[Para 121]The optimized parameters discussed above are also applicable to any of the driving methods of the present invention.

[Para 122]The third driving method therefore may be summarized as follows:

[Para 123]A driving method for an electrophoretic display comprising a first surface on the viewing side, a second surface on the non-viewing side and an electrophoretic fluid which fluid is sandwiched between a common electrode and a layer of pixel electrode and comprises a first type of pigment particles, a second type of pigment particles and a third type of pigment particles, all of which are dispersed in a solvent or solvent mixture, wherein

- a) the three types of pigment particles have optical characteristics differing from one another;
- b) the first type of pigment particles and the second type of pigment particles carry opposite charge polarities; and
- c) the third type of pigment particles has the same charge polarity as the second type of pigment particles but at a lower intensity,

and the method has a voltage insensitive range of at least 0.7V.

[Para 124]In such a method, when a driving voltage within such a range is applied, the optical quality of a color state achieved is at least 90% of the maximum acceptable “ $a^*$ ” value.

[Para 125] It is also noted that the data shown in FIGS. 10A and 10B are collected at ambient temperature.

**The Fourth Driving Method:**

[Para 126] A waveform useful in the fourth driving method of the present invention is illustrated in FIG. 11. This driving waveform may be used to replace the driving period of t3 in FIG. 3.

[Para 127] In an initial step, a high negative driving voltage ( $V_{H2}$ , e.g.,  $-15V$ ) is applied to a pixel for a period of t7 (cf. the corresponding pulse in period t4 in FIG. 4). This pulse is followed by a wait time of t8, during which no voltage is applied. After the wait time, a positive driving voltage ( $V'$ , e.g., less than 50% of  $V_{H1}$  or  $V_{H2}$ ) is applied to the pixel for a period of t9 (cf. the corresponding pulse in period t5 in FIG. 4). After the pulse in t9, but before the various steps of the waveform are repeated, there is a second wait time of t10, during which no voltage is applied. The waveform of FIG. 11 is repeated N times. The term, "wait time", as described above, refers to a period of time in which no driving voltage is applied.

[Para 128] This driving method not only is particularly effective at a low temperature, it can also provide a display device better tolerance of structural variations caused during manufacture of the display device. Therefore its usefulness is not limited to low temperature driving.

[Para 129] In the waveform of FIG. 11, the first wait time t8 is very short while the second wait time t10 is longer. The period of t7 is also shorter than the period of t9. For example, t7 may be in the range of 20-200 msec; t8 may be less than 100 msec; t9 may be in the range of 100-200 msec; and t10 may be less than 1000 msec.

[Para 130] FIG. 12 shows the waveform produced by inserting the waveform of FIG. 11 in place of the period t3 in Figure 3. In FIG. 3, a white state is displayed during the period t2. As a general rule, the better the white state in this period, the better the red state that will be displayed at the end of the waveform.

[Para 131] In the shaking waveform, the positive/negative pulse pair is preferably repeated 50-1500 times and each pulse is preferably applied for 10 msec.

[Para 132] In one embodiment, the step of driving to the white state for a period of t2 may be eliminated and in this case, a shaking waveform is applied before applying the waveform of FIG. 11 (see FIG. 13).

[Para 133] The fourth driving method of FIG. 11 may be summarized as follows:

[Para 134] A driving method for an electrophoretic display comprising a first surface on the viewing side, a second surface on the non-viewing side and an electrophoretic fluid which fluid is sandwiched between a common electrode and a layer of pixel electrodes and comprises a first type of pigment particles, a second type of pigment particles and a third type of pigment particles, all of which are dispersed in a solvent or solvent mixture, wherein

- a) the three types of pigment particles have optical characteristics differing from one another;
- b) the first type of pigment particles and the second type of pigment particles carry opposite charge polarities; and
- c) the third type of pigment particles has the same charge polarity as the second type of pigment particles but at a lower intensity,

the method comprises the following steps:

- (i) applying a first driving voltage to a pixel in the electrophoretic display for a first period of time, wherein the first driving voltage has the same polarity as the first type of pigment particles to drive the pixel towards the color state of the first type of pigment particles at the viewing side;
- (ii) applying no driving voltage to the pixel for a second period of time;
- (iii) applying a second driving voltage to the pixel for a third period of time, wherein the second driving voltage has same polarity as the third type of pigment particles to drive the pixel towards the color state of the third type of pigment particles at the viewing side;
- (iv) applying no driving voltage to the pixel for a fourth period of time; and

repeating steps (i)-(iv).

[Para 135] In one embodiment, the first type of pigment particles is negatively charged and the second type of pigment particles is positively charged.

[Para 136] In one embodiment, steps (i)-(iv) are repeated at least 3 times.

[Para 137] In one embodiment, the second driving voltage is less than 50% of the driving voltage sufficient to drive a pixel from the color state of the first type of pigment particles to the color state of the second type of pigment particles, or *vice versa*.

[Para 138] In another embodiment, the driving sequence of FIG. 12 or FIG. 13 is DC balanced.

**The Fifth Driving Method:**

[Para 139]As shown in FIG. 2(a), because the black particles and the red particles carry the same charge polarity, they tend to move in the same direction. Even though the black particles move faster than the red particles under certain driving voltages because of their higher charge and possibly also smaller size, some of the red particles may still be driven to the viewing side with the black particles, to cause the quality of the black state to degrade.

[Para 140]FIG. 14 depicts a typical waveform for driving a pixel towards the black state. A shaking waveform (explained above) is included to ensure color brightness and purity. As shown, a high positive driving voltage ( $V_{HI}$ , e.g., +15V) is applied for a period of  $t_{12}$  to drive a pixel towards a black state after the shaking waveform. A driving voltage is applied for a period of  $t_{11}$  before the shaking waveform to ensure DC balance.

[Para 141]FIG. 15 illustrates a waveform which may be added at the end of the waveform of FIG. 14, for driving a pixel towards the black state. The combined waveform can further provide better separation of the black particles from the red particles, rendering the black state more saturated, with less red tinting.

[Para 142]In FIG. 15, a short pulse “ $t_{13}$ ” of  $V_{H2}$  (negative) is applied, followed by a longer pulse “ $t_{14}$ ” of  $V_{HI}$  (positive) and a wait time (0V) of  $t_{15}$ . Such a sequence is applied for at least once, preferably at least 3 times (i.e.,  $N$  is  $\geq 3$ ) and more preferably at least five to seven times.

[Para 143]The pulse “ $t_{14}$ ” is usually at least twice the length of the pulse “ $t_{13}$ ”.

[Para 144]The short pulse “ $t_{13}$ ” of  $V_{H2}$  will push the black and red particles towards the pixel electrode and the longer pulse “ $t_{14}$ ” of  $V_{HI}$  will push them to the common electrode side (i.e., the viewing side). Since the speed of the two types of pigment particles are not the same under the same driving voltages, this asymmetrical driving sequence will benefit the black particles more than the red particles. As a result, the black particles can be better separated from the red particles.

[Para 145]The wait time “ $t_{15}$ ” is optional, depending on the dielectric layers in the display device. It is common that at a lower temperature, the resistance of the dielectric layers is more pronounced and, in this case, a wait time may be needed to release the charge trapped in the dielectric layers.

[Para 146]The fifth driving method of FIG. 15 may be summarized as follows:

[Para 147]A driving method for an electrophoretic display comprising a first surface on the viewing side, a second surface on the non-viewing side and an electrophoretic fluid which fluid is sandwiched between a common electrode and a layer of pixel electrodes and comprises a

first type of pigment particles, a second type of pigment particles and a third type of pigment particles, all of which are dispersed in a solvent or solvent mixture, wherein

- a) the three types of pigment particles have optical characteristics differing from one another;
- b) the first type of pigment particles and the second type of pigment particles carry opposite charge polarities; and
- c) the third type of pigment particles has the same charge polarity as the second type of pigment particles but at a lower intensity,

the method comprises the following steps:

- (i) applying a first driving voltage to a pixel in the electrophoretic display for a first period of time, wherein the first driving voltage has the same polarity as the first type of pigment particles to drive the pixel towards the color state of the first type of pigment particles at the viewing side;
- (ii) applying a second driving voltage to the pixel for a second period of time, wherein the second driving voltage has the same polarity as the second type of pigment particles to drive the pixel towards the color state of the second type of pigment particles at the viewing side;
- (iii) optionally applying no driving voltage to the pixel for a third period of time;

and

repeating steps (i), (ii) and (iii) if present.

**[Para 148]**In one embodiment, the first type of pigment particles is negatively charged and the second type of pigment particles is positively charged.

**[Para 149]**FIG. 16 shows the complex waveform combining the waveform of FIG. 14 and the waveform of FIG. 15. However it is also noted that, depending on the particle speed and the cycle number (N) of the sequence, “t12” may be shortened. In other words, at the end of “t12”, the pixel does not have to be at the full black state. Instead, the waveform of FIG. 15 could start at any state from black to white, including grey, provided that the number (N) in the sequence is sufficient to drive the pixel to the black state at the end.

**[Para 150]**The method as described in FIGS. 14-16 may also be utilized to drive a pixel to the black state at a low temperature. In this case, the period t14 should be longer than t13 and the wait time t15 should be at least 50 msec.

**[Para 151]**In one embodiment, the driving sequence of FIG. 16 is DC balanced.

**The Sixth Driving Method:**

[Para 152] FIG. 17 depicts a typical waveform for driving a pixel to a white state. A shaking waveform (explained above) is included to ensure color brightness and purity. A driving voltage of  $V_{H2}$  is applied for a period of  $t_{17}$  after the shaking waveform. A driving voltage of  $V_{H1}$  is applied for a period of  $t_{16}$  before the shaking waveform to ensure DC balance.

[Para 153] FIGS. 18A and 18B show waveforms which may be used to replace the pulse  $t_{17}$  in the waveform of FIG. 17.

[Para 154] This driving method is particularly suitable for low temperature driving, although it is not limited to low temperature driving.

[Para 155] In FIG. 18A, a short pulse “ $t_{18}$ ” of  $V_{H1}$  (positive) is applied, followed by a longer pulse “ $t_{19}$ ” of  $V_{H2}$  (negative) and a wait time (0V) of  $t_{20}$ . As shown in FIG. 18B, the amplitude of the negative driving voltage ( $V''$ ) applied during  $t_{19}$  may be higher than that of  $V_{H2}$  (e.g.,  $-30V$  instead of  $-15V$ ).

[Para 156] Such a sequence is applied for at least once, preferably at least 3 times (i.e.,  $N$  is  $\geq 3$  in FIGS. 18A and 18B, and more preferably at least five to seven times.

[Para 157]  $t_{19}$  should be longer than  $t_{18}$ . For example,  $t_{18}$  may be in the range of 20-200 msec and  $t_{19}$  may be less than 1000 msec. The wait time  $t_{20}$  should be at least 50 msec.

[Para 158] The sixth driving method as shown in FIGS. 18A and 18B may be summarized as follows:

[Para 159] A driving method for an electrophoretic display comprising a first surface on the viewing side, a second surface on the non-viewing side and an electrophoretic fluid which fluid is sandwiched between a common electrode and a layer of pixel electrodes and comprises a first type of pigment particles, a second type of pigment particles and a third type of pigment particles, all of which are dispersed in a solvent or solvent mixture, wherein

- a) the three types of pigment particles have optical characteristics differing from one another;
- b) the first type of pigment particles and the second type of pigment particles carry opposite charge polarities; and
- c) the third type of pigment particles has the same charge polarity as the second type of pigment particles but at a lower intensity,

the method comprises the following steps:

- (i) applying a first driving voltage to a pixel in the electrophoretic display for a first period of time, wherein the first driving voltage has the same polarity as the

second type of pigment particles to drive the pixel towards the color state of the second type of pigment particles at the viewing side;

- (ii) applying a second driving voltage to the pixel for a second period of time, wherein the second driving voltage has the same polarity as the first type of pigment particles to drive the pixel towards the color state of the first type of pigment particles at the viewing side;

- (iii) applying no driving voltage to the pixel for a third period of time; and

repeating steps (i) and (ii).

[Para 160] In one embodiment, the first type of pigment particles is negatively charged and the second type of pigment particles is positively charged.

[Para 161] In one embodiment as shown in FIG. 18A, the second voltage is the driving voltage required to drive a pixel from the color state of the first type of pigment particles towards the color state of the second type of pigment particles, or vice versa.

[Para 162] In another embodiment as shown in FIG. 18B, the second voltage has a amplitude higher than that of the driving voltage required to drive a pixel from the color state of the first type of pigment particles towards the color state of the second type of pigment particles, or vice versa.

[Para 163] FIGS. 19A and 19B show complex waveforms combining the waveform of FIG. 17 with the waveform of FIG. 18A or 18B, respectively.

[Para 164] In the shaking waveform, the positive/negative pulse pair is preferably repeated 50-1500 times and each pulse is preferably applied for 10 msec.

[Para 165] In one embodiment, the driving sequence of FIG. 19A or FIG. 19B is DC balanced.

#### **The Seventh Driving Method:**

[Para 166] The seventh driving method of the present invention drives a pixel towards an intermediate color state (e.g., grey).

[Para 167] FIGS. 20A and 20B illustrates the particle movements involved. As shown, a pixel in the black state (see FIG. 20A) is driven towards a grey state when a low negative driving voltage ( $V_L$ , e.g.,  $-5V$ ) is applied. In the process, the low driving voltage pushes the red particles towards the pixel electrode and a mixture of black and white particles is seen at the viewing side.

[Para 168] The waveform used for this driving method is shown in FIG. 21. A high positive driving voltage ( $V_{HI}$ , e.g.,  $+15V$ ) is applied for a time period of  $t_{22}$  to drive a pixel towards a black state, after a shaking waveform. From the black state, the pixel may be driven towards

the grey state by applying a low negative driving voltage ( $V_L$ , e.g.,  $-5V$ ) for a period of  $t_{23}$ , that is, driven from FIG. 20A to FIG. 20B.

[Para 169] The driving period  $t_{22}$  is a time period sufficient to drive a pixel to the black state when  $V_{HI}$  is applied, and  $t_{23}$  is a time period sufficient to drive the pixel to the grey state from the black state when  $V_L$  is applied. Prior to the shaking waveform, a pulse of  $V_{HI}$  is preferably applied for a period of  $t_{21}$  to ensure DC balance.

[Para 170] FIG. 22 illustrates to a driving waveform which may be used to replace the pulse  $t_{23}$  in FIG. 21. In an initial step, a high positive driving voltage ( $V_{HI}$ , e.g.,  $+15V$ ) is applied for a short period of  $t_{24}$  to push the black particles towards the viewing side, but  $t_{24}$  is not sufficient to drive the pixel to the full black state, and is followed by applying a low negative driving voltage ( $V_L$ , e.g.,  $-5V$ ) for a period of  $t_{25}$  to drive the pixel towards a grey state. The amplitude of  $V_L$  is less than 50% of  $V_H$  (e.g.,  $V_{HI}$  or  $V_{H2}$ ).

[Para 171] The waveform of FIG. 22 is repeated for at least 4 cycles ( $N \leq 4$ ), preferably at least 8 cycles.

[Para 172] The time period,  $t_{24}$  is less than about 100 msec and  $t_{25}$  is usually greater than 100 msec, both at ambient temperature.

[Para 173] The seventh driving method as shown in FIG. 22 may be summarized as follows:

[Para 174] A driving method for an electrophoretic display comprising a first surface on the viewing side, a second surface on the non-viewing side and an electrophoretic fluid which fluid is sandwiched between a common electrode and a layer of pixel electrodes and comprises a first type of pigment particles, a second type of pigment particles and a third type of pigment particles, all of which are dispersed in a solvent or solvent mixture, wherein

- a) the three types of pigment particles have optical characteristics differing from one another;
- b) the first type of pigment particles and the second type of pigment particles carry opposite charge polarities; and
- c) the third type of pigment particles has the same charge polarity as the second type of pigment particles but at a lower intensity,

which method comprises the following steps:

- (i) applying a first driving voltage to a pixel in the electrophoretic display for a first period of time, which first driving voltage has the same polarity as the second type of pigment particles to drive the pixel towards the color state of the second type of pigment particles wherein the first period of time is not sufficient to

drive the pixel to the full color state of the second type of pigment particles at the viewing side;

- (ii) applying a second driving voltage to the pixel for a second period of time, which second driving voltage has the same polarity as the first type of pigment particles to drive the pixel towards a mixed state of the first and second types of pigment particles at the viewing side; and

repeating steps (i) and (ii).

[Para 175] As stated above, the second driving voltage is about 50% of the first driving voltage, in this method.

[Para 176] FIG. 23 shows the complex waveform combining the waveform of FIG. 21 and the waveform of FIG. 22, in which the driving period  $t_{23}$  in FIG. 21 is replaced with the waveform of FIG. 22. The complex waveform consists of four phases. The first phase is the DC balance phase ( $t_{21}$ ); the second phase is a shaking step; and the third phase is driving a pixel to the black state ( $t_{22}$ ). The waveform used in the third phase can be any waveform which drives the pixel to a good black state. The fourth phase consists of a high positive driving voltage for a short period of time  $t_{24}$ , followed by a low negative driving voltage for a longer period of time  $t_{25}$ . The fourth phase, as stated, is repeated several times.

[Para 177] It is noted that in FIG. 23,  $t_{22}$  may be optional.

[Para 178] It is possible to modulate the grey state to be brighter or darker by changing the low negative voltage ( $V_L$ ). In other words, the waveform sequence and shape may remain the same; but the amplitude of  $V_L$  varies (e.g.  $-4V$ ,  $-5V$ ,  $-6V$  or  $-7V$ ) to cause different grey levels to be displayed. This feature could potentially reduce the required space for the look-up tables in the driving circuit, consequently lowering the cost. The driving method as illustrated can produce a high quality of an intermediate state (of the first type of pigment particles and the second type of pigment particles) with very little color interference from the third type of pigment particles.

[Para 179] In one embodiment, the driving sequence of FIG. 23 is DC balanced.

#### **The Eighth Driving Method:**

[Para 180] FIG. 24 illustrates a waveform used in the eighth driving method of the present invention. This waveform is intended to be applied to a pixel which is not in a white state (i.e., the color state of the first type of pigment particles).

[Para 181] In an initial step, a high negative driving voltage ( $V_{H2}$ , e.g.,  $-15V$ ) is applied for a period of  $t_{26}$ , which is followed by a wait time of  $t_{27}$ . After the wait time, a positive driving voltage ( $V'$ , e.g., less than 50% of  $V_{H1}$  or  $V_{H2}$ ) is applied for a period of  $t_{28}$ , which is followed

by a second wait time of  $t_{29}$ . The waveform of FIG. 24 is repeated N times. The term, “wait time”, as described above, refers to a period of time in which no driving voltage is applied.

[Para 182] This driving method is particularly effective at a low temperature, and it may also shorten the overall driving time to the red state.

[Para 183] It is noted that the time period  $t_{26}$  is rather short, usually in the range of about 50% of the time required to drive from a full black state to a full white state and therefore it is not sufficient to drive a pixel to a full white color state. The time period  $t_{27}$  may be less than 100 msec; the time period  $t_{28}$  may range of 100-200 msec; and the time period  $t_{29}$  may be less than 1000 msec.

[Para 184] The waveform of FIG. 24 is similar to that of FIG. 11, except that the waveform of FIG. 11 is to be applied to a pixel which is in a white state (i.e., the color of the first type of pigment particles) whereas the waveform of FIG. 24 is intended to be applied to a pixel which is not in a white state.

[Para 185] FIG. 25 is an example wherein the waveform of FIG. 24 is applied to a pixel which is at a black state (i.e., the color state of the second type of pigment particles).

[Para 186] In the shaking waveform, the positive/negative pulse pair is preferably repeated 50-1500 times and each pulse is preferably applied for 10 msec.

[Para 187] The eighth driving method of FIG. 24, like that of FIG. 11, may be summarized as follows:

[Para 188] A driving method for an electrophoretic display comprising a first surface on the viewing side, a second surface on the non-viewing side and an electrophoretic fluid which fluid is sandwiched between a common electrode and a layer of pixel electrodes and comprises a first type of pigment particles, a second type of pigment particles and a third type of pigment particles, all of which are dispersed in a solvent or solvent mixture, wherein

- a) the three types of pigment particles have optical characteristics differing from one another;
- b) the first type of pigment particles and the second type of pigment particles carry opposite charge polarities; and
- c) the third type of pigment particles has the same charge polarity as the second type of pigment particles but at a lower intensity,

the method comprises the following steps:

- (i) applying a first driving voltage to a pixel in the electrophoretic display for a first period of time, wherein the first driving voltage has the same polarity as the first

type of pigment particles to drive the pixel towards the color state of the first type of pigment particles at the viewing side;

- (ii) applying no driving voltage to the pixel for a second period of time;
- (iii) applying a second driving voltage to the pixel for a third period of time, wherein the second driving voltage has same polarity as the third type of pigment particles to drive the pixel towards the color state of the third type of pigment particles at the viewing side;
- (iv) applying no driving voltage to the pixel for a fourth period of time; and

repeating steps (i)-(iv).

[Para 189] In one embodiment, the first type of pigment particles is negatively charged and the second type of pigment particles is positively charged.

[Para 190] In one embodiment, steps (i)-(iv) are repeated at least 3 times.

[Para 191] In one embodiment, the second driving voltage is less than 50% of the driving voltage sufficient to drive a pixel from the color state of the first type of pigment particles to the color state of the second type of pigment particles, or vice versa.

[Para 192] In one embodiment, the driving sequence of FIG. 25 is DC balanced.

#### **Production of Intermediate Colors:**

[Para 193] It is advantageous for the driving methods of the present invention to be capable of displaying intermediate colors (i.e., mixtures of the colors of two particles) in addition to the colors of single particles. In many cases, the displays in which the present methods are to be used will be required to display gray scale images which will require areal modulation of the display. Such areal modulation increases the number of colors which can be displayed, but at the expense of decreasing the resolution of the display, since a number of pixels of the display are subjected to areal modulation to form one gray scale "super pixel". Providing each pixel of the display with the ability to display intermediate colors, and increasing the number of intermediate colors which each pixel can display reduces the number of pixels which must be used in each super pixel, and hence increases the resolution of the gray scale display.

[Para 194] One method for the production of an intermediate gray color (i.e., a mixture of the colors of the black and white particles) has already been discussed above with reference to FIGS. 20A and 20B. A gray color may also be produced by first driving a pixel to either the black or white state (FIG. 2A or 2B respectively) and then applying the high driving voltage of  $\pm 15$  V to drive the pixel towards the white or black state respectively, but terminating this driving voltage before the white or black state is reached, thus producing a gray state. However,

it should be noted that, in the three particle systems used in the present methods, it is advantageous to produce a gray state using this method starting from the white state rather than from the black state, for reasons which will be explained with reference to FIGS. 26A-26D.

**[Para 195]** FIGS. 26A and 26B illustrate the production of a gray state starting from a white state. FIG. 26A (which is identical in substance to FIG. 2B) illustrates the production of a white state by application of a high negative driving voltage ( $-15\text{V}$ ,  $V_{H2}$ ), which drives the white particles 21 to the viewing side and the black particles 22 and red particles 23 towards the pixel electrode. From the white state of FIG. 26A, a brief driving pulse of a high positive voltage ( $+15\text{V}$ ,  $V_{H1}$ ) drives the white particles towards the pixel electrode and the black and red particles towards the viewing side. The brief driving pulse is terminated at a time when the white and black particles are intermixed adjacent the viewing side. Since the red particles have a lower electrophoretic mobility than the black particles, the red particles move more slowly away from the pixel electrode, and thus in the gray state are screened from a viewer by the black and white particles, which lie between the red particles and the viewing surface. Accordingly, FIG. 26B presents a “clean” gray color consisting only of a mixture of the colors of the black and white particles and free from contamination by the color of the red particles.

**[Para 196]** In contrast, FIGS. 26C and 26D illustrate the production of a gray state starting from a black state. FIG. 26C (which is identical in substance to FIG. 2A) illustrates the production of a black state by application of a high positive driving voltage ( $+15\text{V}$ ,  $V_{H1}$ ), which drives the black particles 22 and red particles 23 towards the viewing side, and the white particles 21 adjacent the pixel electrode. From the black state of FIG. 26C, a brief driving pulse of a negative voltage ( $-15\text{V}$ ,  $V_{H2}$ ) drives the white particles towards the viewing side and the black and red particles towards the pixel electrode. The brief driving pulse is terminated at a time when the white and black particles are intermixed adjacent the viewing side. However, since the red particles have a lower electrophoretic mobility than the black particles, the red particles move more slowly away from the viewing side, and thus in the gray state are admixed with the black and white particles; indeed, there may be a tendency for the red particles to lie closer to the viewing side than the black particles. Accordingly, FIG. 26D presents a “dirty” gray color in which the mixture of the colors of the black and white particles is significantly contaminated by the color of the red particles.

**[Para 197]** As already noted, a gray color state of a pixel may be produced starting from either a black color state or a white color state. Similarly, a light red color state (a mixture of the colors of the white and red particles) may be produced starting from either a red color state or

a white color state. In the former case, one first drives to a full red color state (see FIG. 2C) and then applies a high negative driving voltage ( $-15V$ ,  $V_{H2}$ ) for a brief period of time, insufficient to reach the white color state of FIG. 2B. The high negative driving voltage causes the white particles 21 to move rapidly towards the viewing side, the black particles 22 to move rapidly towards the pixel electrode, and the red particles 23 to move more slowly towards the pixel electrode. The driving voltage is terminated while the white and red particles are intermingled, thus leaving a light red color visible at the viewing side. The black particles lie near the pixel electrode and thus are screened from a viewer by the white and red particles. In the latter case, one first drives to the full white state (see FIG. 2b) and applies a low positive driving voltage ( $+5V$ ,  $V_L$ ) for a period of time insufficient to reach the red state of FIG. 2C. The low negative driving voltage causes the white particles 21 to move towards the pixel electrode and the red particles to move towards the viewing side, thus again producing an admixture of the red and white particles and the display of a light red color. Instead of using a continuous low negative driving voltage, the transition from a white state to a light red state may be achieved using a push-pull waveform such as that illustrated in FIG. 5, 6, 8 or 9.

**[Para 198]** It has been found empirically that the light red state produced from a red state is much less uniform than that produced from a white state. Although the reasons for this difference in uniformity are not entirely understood, it is believed to be related to variations of the positions of the various particles within microcapsules (if present) and variations in the electrophoretic mobilities of individual particles, and of the various parts of the electrophoretic display. It also appears that the low driving voltage used in the drive from the red color state is more affected by variations in power supplies than the higher driving voltage.

**[Para 199]** FIG. 27 illustrates a waveform used to drive the display to a light red state via a white state. In the waveform of FIG. 27, a high negative driving voltage ( $V_{H2}$ , e.g.,  $-15V$ ) is applied for a period of  $t_{31}$  to drive the pixel towards a white state. From the white state, the pixel is driven towards a red state by applying a low positive voltage ( $V_L$ , e.g.,  $+5V$ ) for a period of  $t_{32}$ , thus driving the pixel from the state of FIG. 2B to that of FIG. 2C. Finally, the pixel is driven from the red state to the light red state by applying a high negative driving voltage ( $V_{H2}$ , e.g.,  $-15V$ ) for a period  $t_{33}$ , which is shorter than the period  $t_{31}$  and insufficient to drive the pixel to a full white state. A shaking waveform is desirably applied before the white-going pulse in period  $t_{31}$ , and a negative driving voltage (for example,  $V_{H2}$ , e.g.,  $-15V$ ) is preferably applied for a period of  $t_{30}$  prior to the shaking waveform to ensure DC balance. It will be seen that the waveform of FIG. 27 is essentially that of FIG. 3 but with the addition

of the white-going pulse in period t33. The exact shade of light red achieved can be varied by adjusting the duration of period t33, which will typically be in the range of about 20-300 msec, usually 20-100 msec. The duration of period t33 will typically be from about 10 to about 60 per cent of the duration of period t31.

**[Para 200]** Achieving a dark red color state (i.e., a mixture of the colors of the black and red particles) is much more difficult than achieving the light red color state because the black and red particles carry charges of the same polarity, and hence tend to react to applied electric fields in similar ways. For example, if one first drives a pixel to the red state of FIG. 2C and then attempts to produce an admixture of the red and black particles by applying the high positive drive voltage (+15V,  $V_{HI}$ ) used to drive the pixel to the black state of FIG. 2A, the red particles, which are already adjacent the front electrode as shown in FIG. 2C will remain adjacent this front electrode and will not move aside to accommodate the arriving black particles. The result is that even after the high positive drive voltage has been applied for a long period, even longer than the period required to drive the pixel from the white state of FIG. 2B to the black state of FIG. 2A, the resultant “dark red” state will in fact be only slightly darker than the previous red state.

**[Para 201]** It has been found that there are two methods to achieve a satisfactory dark red state. The first method uses a waveform as illustrated in FIG. 28, and essentially starts from a dark gray color state. As shown in that Figure, this waveform first applies a high positive drive voltage (+15V,  $V_{HI}$ ) to drive the pixel to a dark gray state (*not* a full black state). This high positive drive voltage is followed by a low positive drive voltage ( $V_L$ , e.g., +5V) for a period of t36, which will normally be significantly longer than t35, to drive the pixel to a dark red state. For reasons explained about, the high positive drive pulse in period t35 may optionally be preceded by a shaking waveform and/or a high negative drive voltage pulse ( $V_{H2}$ , e.g., -15V) for a period t34. The duration of t36 can vary widely but may typically be about 300-2000 msec, and more usually 500-1000 msec; the darkness of the dark red color produced can be varied by varying the duration of t36, with longer durations tending to increase the redness of the color produced.

**[Para 202]** The second method of achieving a satisfactory dark red state uses a waveform as illustrated in FIG. 29, which is identical in substance to FIG. 5, although for reasons discussed below the durations of the various drive pulses shown in FIG. 29 will vary from those in FIG. 5. It will be recalled from the discussion of FIG. 5 above that the main part of the relevant waveform comprises red-going pulses of a low positive drive voltage ( $V_L$ , e.g., +5V), indicated

as of duration  $t_{39}$  in FIG. 29, alternating with white-going pulses of a high negative drive voltage ( $V_{H2}$ , e.g.,  $-15V$ ) indicated as of duration  $t_{40}$  in FIG. 29. This sequence of alternating pulses may be preceded by any one or more of (a) a white-going pulse of a high negative drive voltage ( $V_{H2}$ , e.g.,  $-15V$ ) of duration  $t_{37}$ , intended for DC balance; (b) a shaking waveform; and (c) a white-going pulse of a high negative drive voltage ( $V_{H2}$ , e.g.,  $-15V$ ) of duration  $t_{38}$ , which may or may not differ from the duration  $t_{40}$  of the later white-going pulses already mentioned.

[Para 203] The waveform of FIG. 5 was described above as producing a pure red color state. However, it has been found empirically that, by adjusting the durations  $t_{39}$  and  $t_{40}$  in FIG. 29, and/or by adjusting the drive voltages  $V'$  and  $V_{H2}$  applied during these periods, this type of waveform can generate not only a pure red color state but also dark red and light red color states. If the magnitude of  $V'$  is increased, the red color becomes darker, whereas if the magnitude of  $V'$  is decreased, the red color becomes lighter. Similarly, if the duration of  $t_{40}$  is increased relative to  $t_{39}$ , a lighter red color will be produced, whereas if the duration of  $t_{39}$  is increased relative to  $t_{40}$ , a darker red color will be produced. Obviously, combinations of changes in both driving voltage and duration may be used. The durations of  $t_{39}$  and  $t_{40}$  can vary over a wide range; for example at  $25^{\circ}C$ ,  $t_{40}$  can vary from 60 down to 20 msec while  $t_{39}$  may vary from 300 up to 600 msec. Even wider ranges may be desirable at low temperatures such as  $0^{\circ}C$ ; for example, at this temperature  $t_{40}$  may be 60 msec and  $t_{39}$  3000 msec.

### Example 2

[Para 204] An electrophoretic medium substantially as described above with reference to FIG. 1 was prepared by mixing 30 per cent by weight polymer-coated titania particles (white), 8 per cent by weight polymer-coated mixed metal oxide particles (black) and 7 per cent by weight of red pigment particles in an isoparaffin solvent and adding a charge control agent (Solsperse 19000). The white particles bore negative charges, while both the black and the red particles bore positive charges, but the red particles had a lower charge density than the black particles. The resultant electrophoretic medium was loaded into a standard test cell provided with an essentially transparent front electrode and driven to its white, black, red and gray states as described above with reference to FIGS. 2A, 2B, 2C and 26B respectively. The  $L^*$ ,  $a^*$  and  $b^*$  values for all four colored states were measured using standard techniques, and the results were as follows:

[Para 205]

**Table 1**

Color	L*	a*	b*
White	60.2	-1.0	-1.4
Black	12.6	7.7	-0.8
Red	27.0	37.9	17.6
Gray	38.4	-1.0	-4.0

[Para 206] The reflectance, Y, of the gray state was 10.3 per cent. It will be seen from these results that the experimental medium of the present invention was capable of displaying good white, black and red states, and was also capable of displaying a gray state.

[Para 207] While the present invention has been described with reference to the specific embodiments thereof, it should be understood by those skilled in the art that various changes may be made and equivalents may be substituted without departing from the true spirit and scope of the invention. In addition, many modifications may be made to adapt a particular situation, materials, compositions, processes, process step or steps, to the objective and scope of the present invention. All such modifications are intended to be within the scope of the claims appended hereto.

## CLAIMS

1. A driving method for an electrophoretic display comprising a first surface on a viewing side, a second surface on a non-viewing side and an electrophoretic fluid which comprises a first type of pigment particles, a second type of pigment particles and a third type of pigment particles, all of which are dispersed in a liquid, wherein

- a) the three types of pigment particles have optical characteristics differing from one another;
- b) the first type of pigment particles and the second type of pigment particles carry opposite charge polarities; and
- c) the third type of pigment particles has the same charge polarity as the second type of pigment particles but a lower zeta potential,

the method comprising the following steps:

- (i) applying a first driving voltage to a pixel in the electrophoretic display for a first period of time, the first driving voltage having a polarity driving the first type of pigment particles towards the first surface, thereby causing the pixel to display the optical characteristic of the first type of pigment particles at the first surface;
- (ii) applying a second driving voltage to the pixel for a second period of time, the second driving voltage having a polarity driving the third type of pigment particles towards the first surface, thereby driving the pixel towards the optical characteristic of the third type of pigment particles at the first surface; and
- (iii) applying a third driving voltage for a third period of time, the third driving voltage having the same polarity as the first driving voltage, and the third period of time

being shorter than the first period of time, thereby producing a mixture of the optical characteristics of the first and third types of pigment particles at the first surface.

2. A method according to claim 1 wherein a duration of the third period of time is from about 20 to about 80 per cent of the duration of the first period of time.

3. A method according to claim 2 wherein the duration of the third period of time is from about 20 to about 40 per cent of the duration of the first period of time.

4. A method according to claim 1 further comprising applying a shaking waveform prior to step (i).

5. A method according to claim 4 further comprising applying, prior to the shaking waveform, a driving voltage driving the first type of pigment particles towards the first surface.

6. A driving method for an electrophoretic display comprising a first surface on a viewing side, a second surface on a non-viewing side and an electrophoretic fluid which comprises a first type of pigment particles, a second type of pigment particles and a third type of pigment particles, all of which are dispersed in a liquid, wherein

- a) the three types of pigment particles have optical characteristics differing from one another;
- b) the first type of pigment particles and the second type of pigment particles carry opposite charge polarities; and

- c) the third type of pigment particles has the same charge polarity as the second type of pigment particles but a lower zeta potential,

the method comprising the following steps:

- (i) applying a first driving voltage to a pixel in the electrophoretic display for a first period of time, the first driving voltage having a polarity driving the second type of pigment particles towards the first surface, thereby causing the pixel to display the optical characteristic of the second type of pigment particles at the first surface; and
- (ii) applying a second driving voltage to the pixel for a second period of time, the second driving voltage having the same polarity as, but a lower magnitude than the first driving voltage, thereby driving the third type of pigment particles at the first surface, and producing a mixture of the optical characteristics of the second and third types of pigment particles at the first surface.

7. A method according to claim 6 wherein a duration of the second period of time is from about 100 to about 150 per cent of the duration of the first period of time.

8. A method according to claim 6 further comprising applying a shaking waveform prior to step (i).

9. A method according to claim 8 further comprising applying, prior to the shaking waveform, a driving voltage driving the first type of pigment particles towards the first surface.

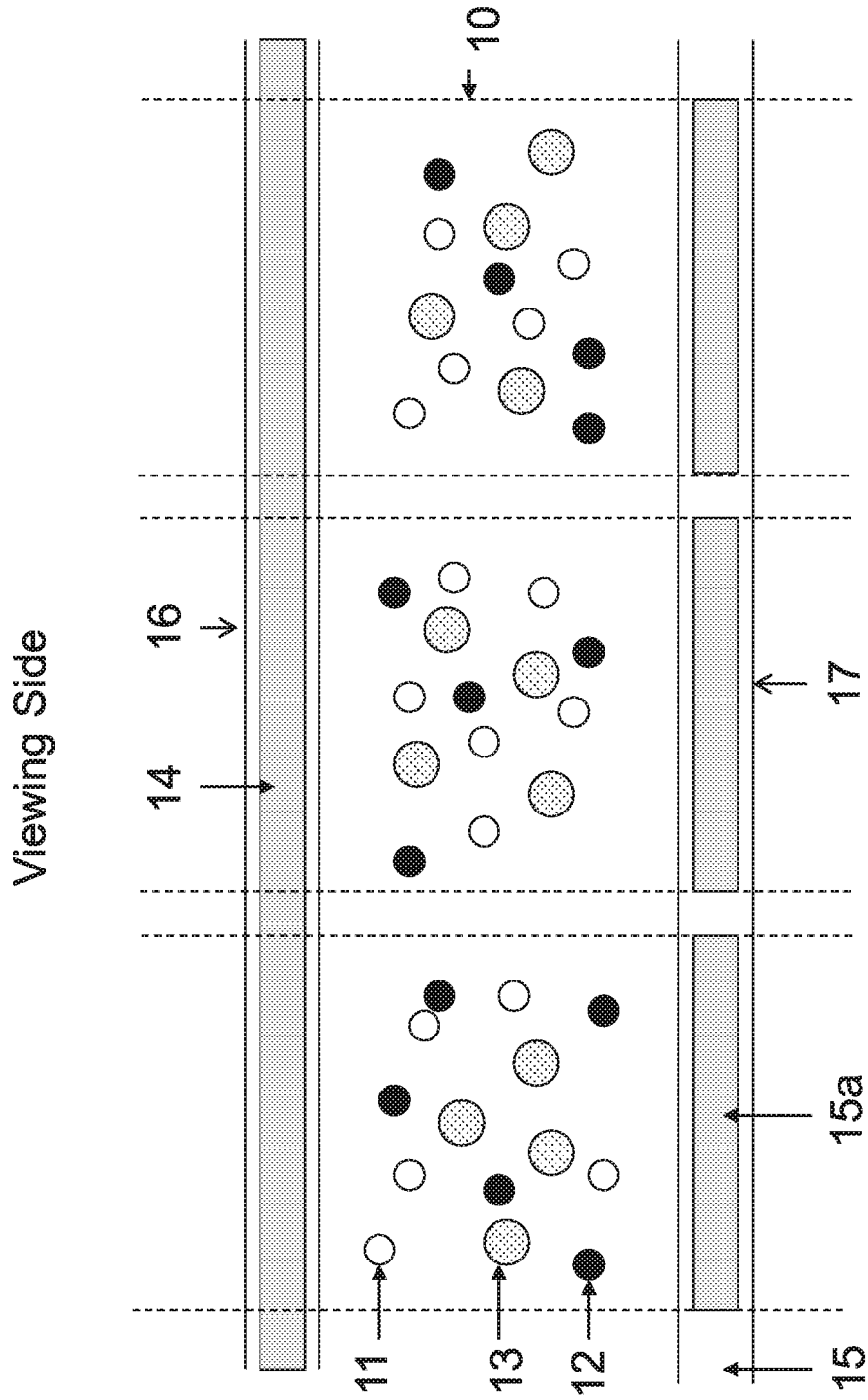

Fig. 1

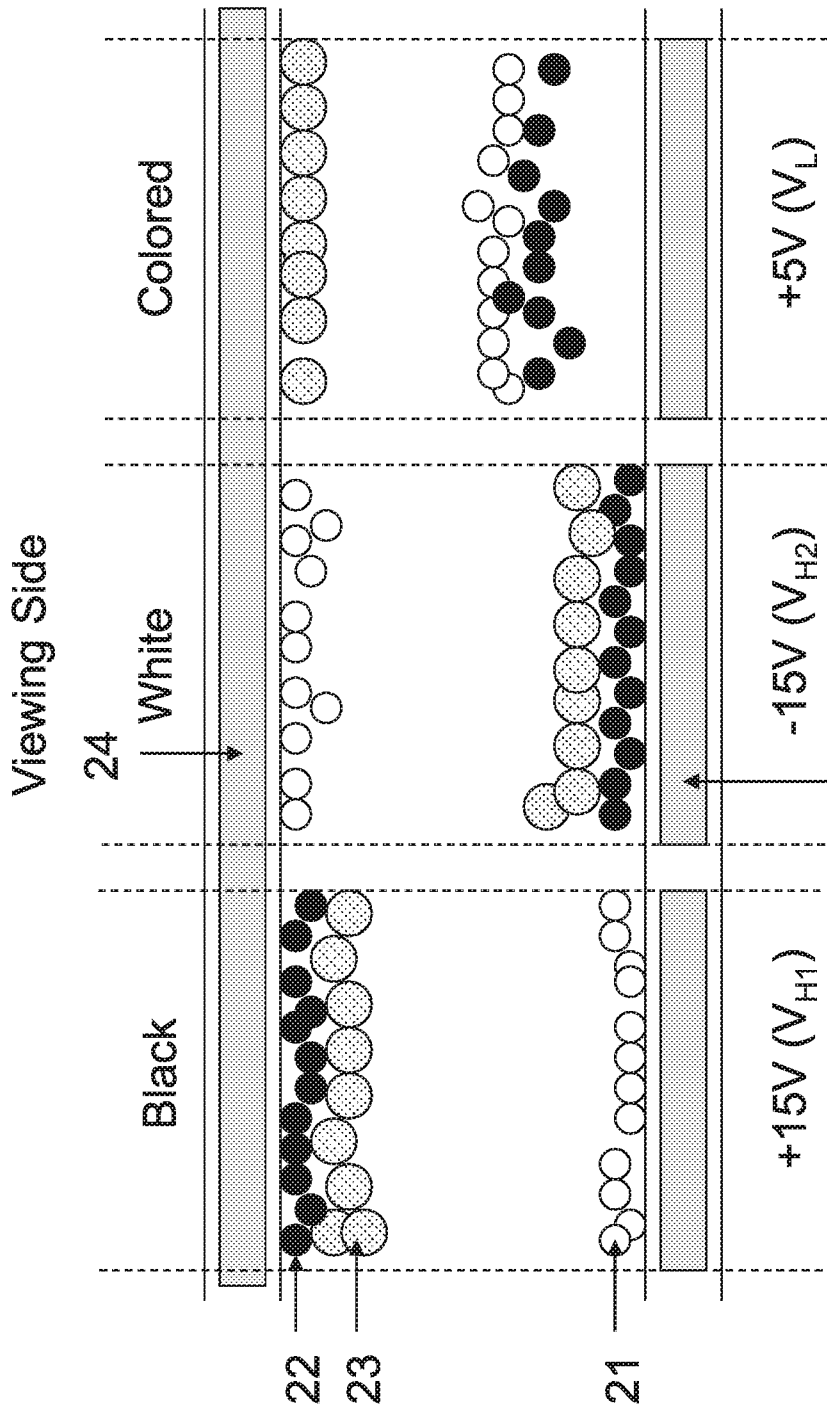

Fig. 2C

Fig. 2B

Fig. 2A

25

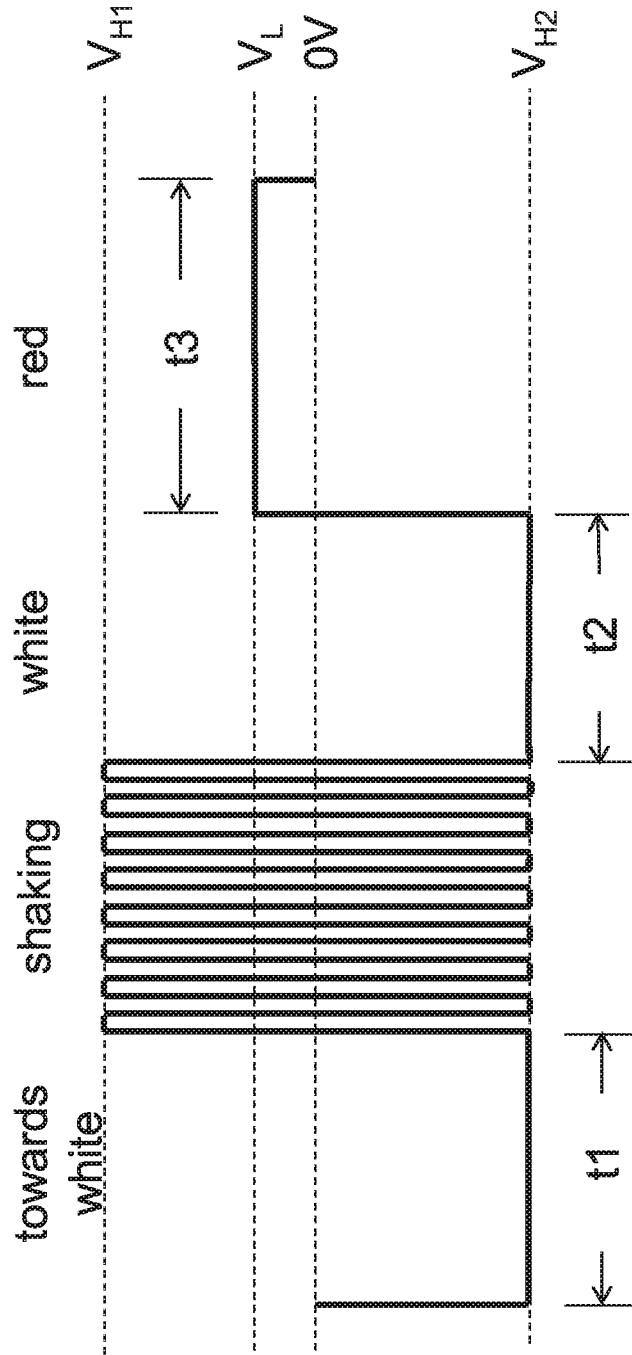

Fig. 3

4/33

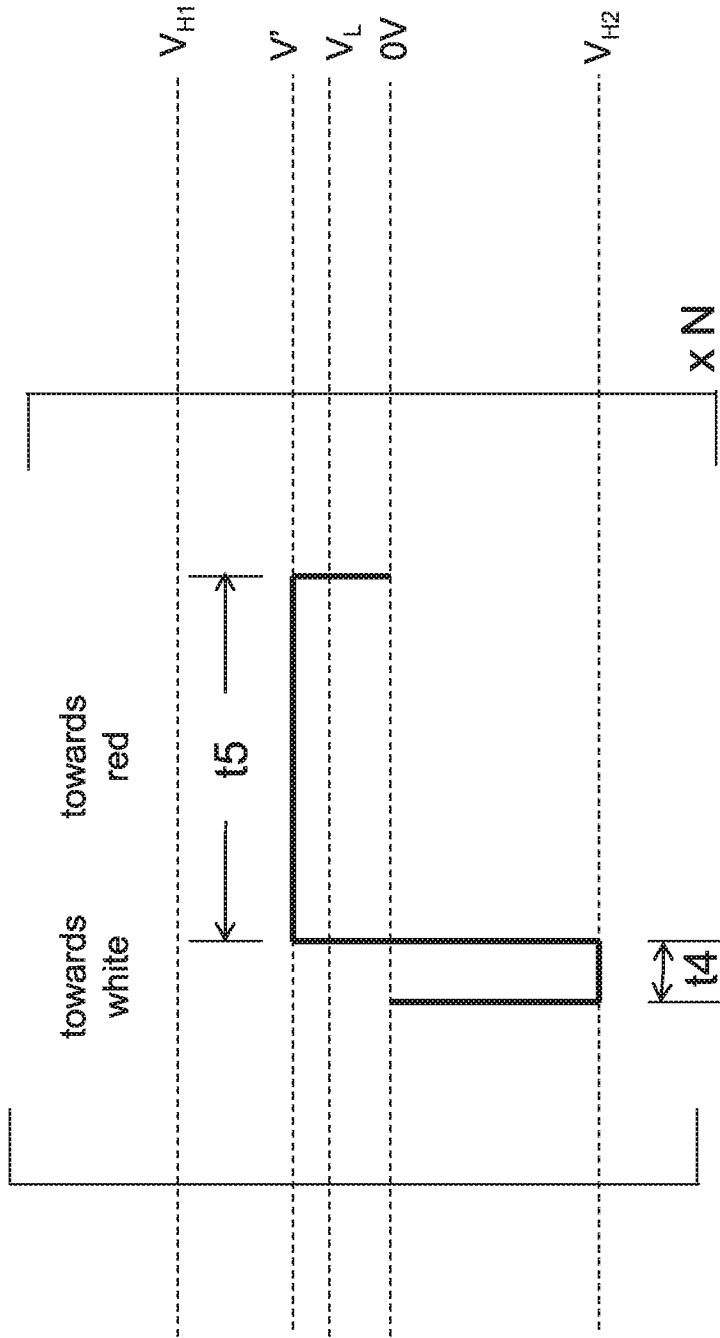

Fig. 4

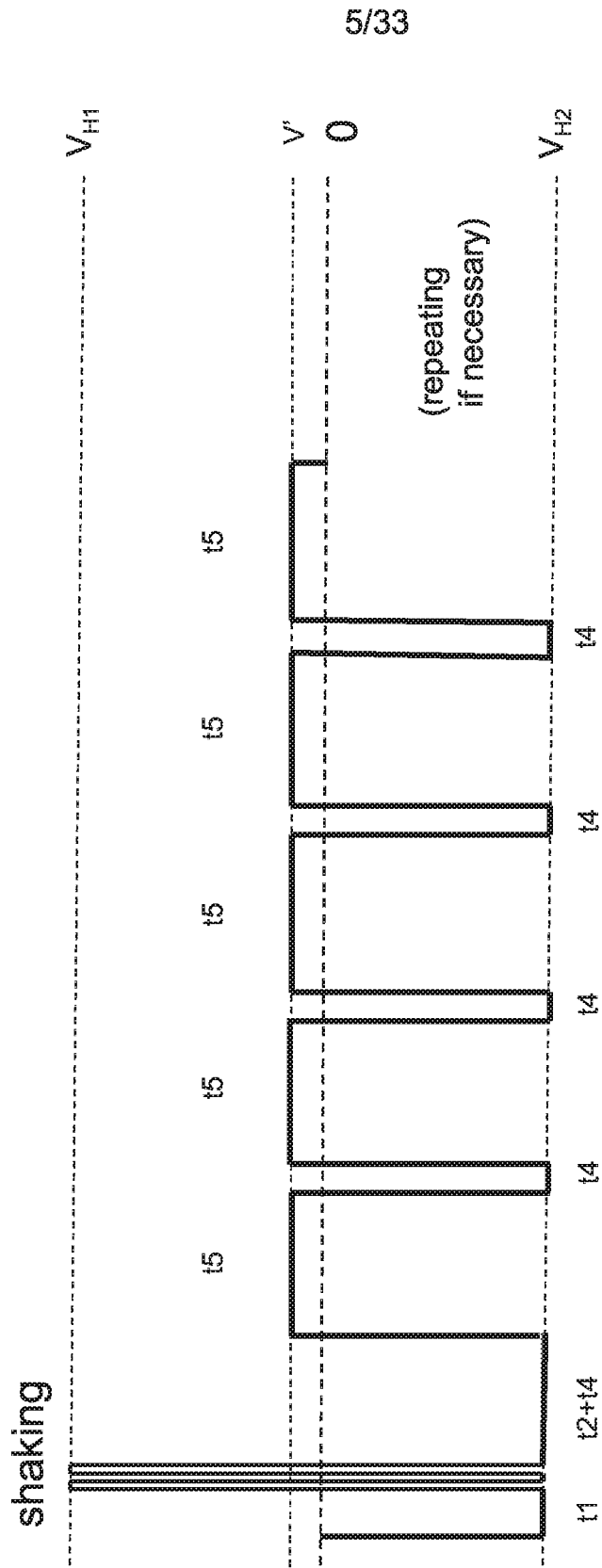

Fig. 5

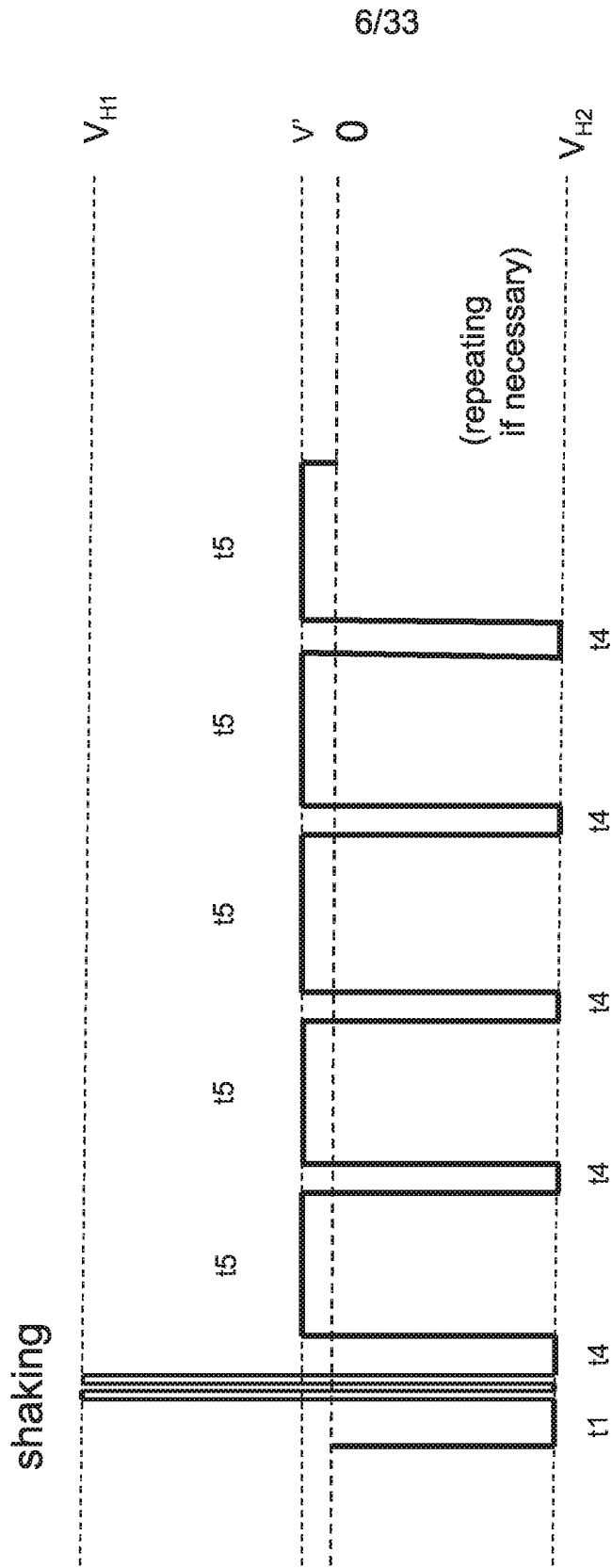

Fig. 6

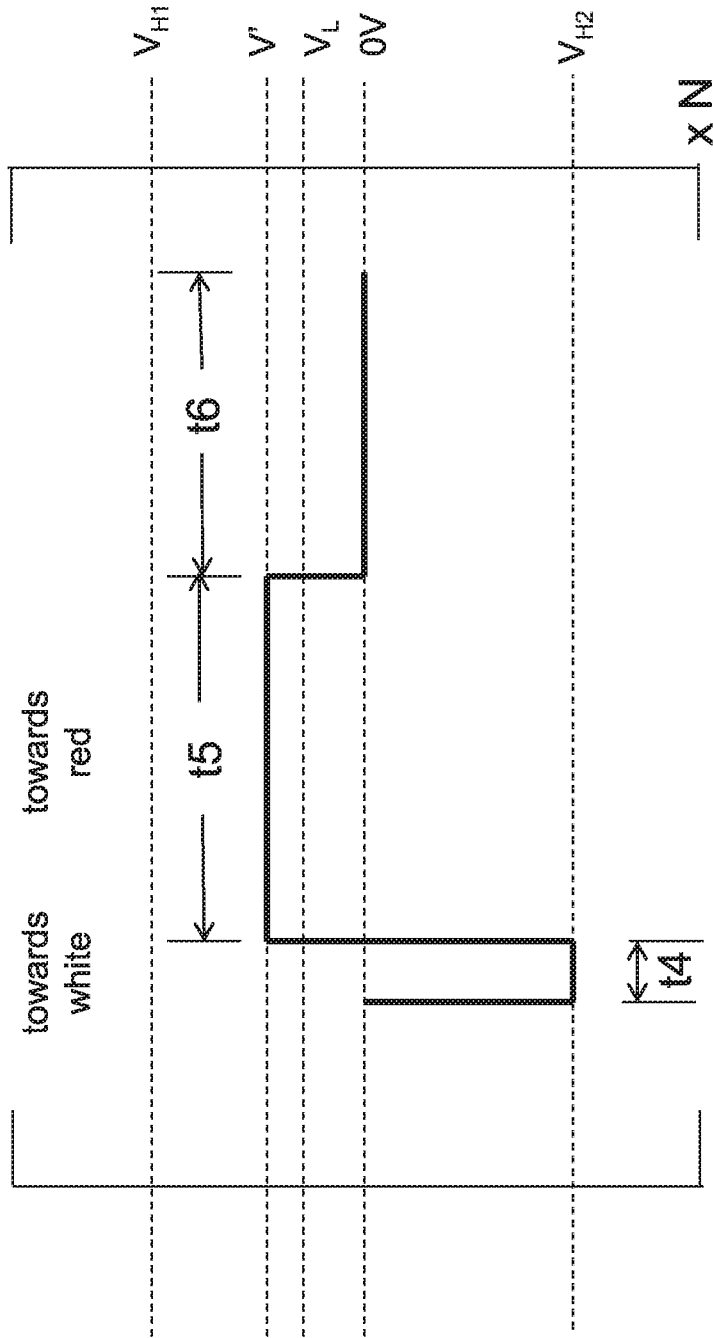

Fig. 7

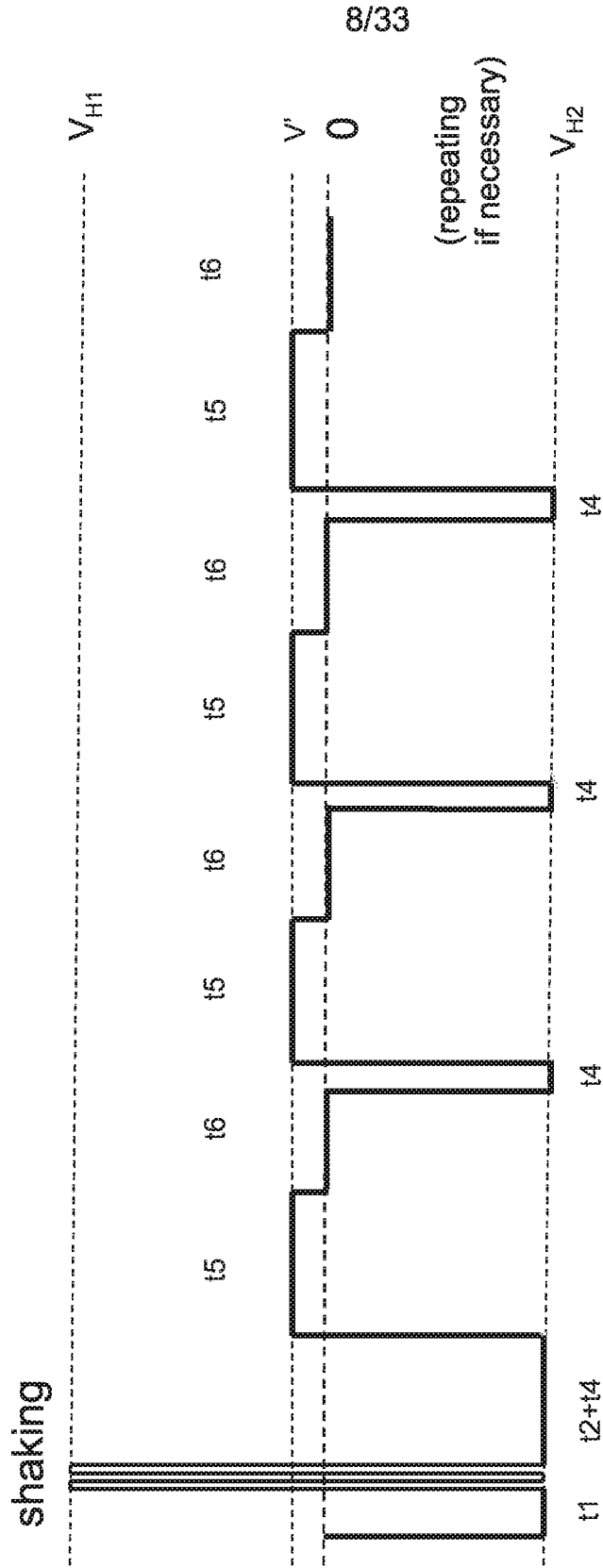

Fig. 8

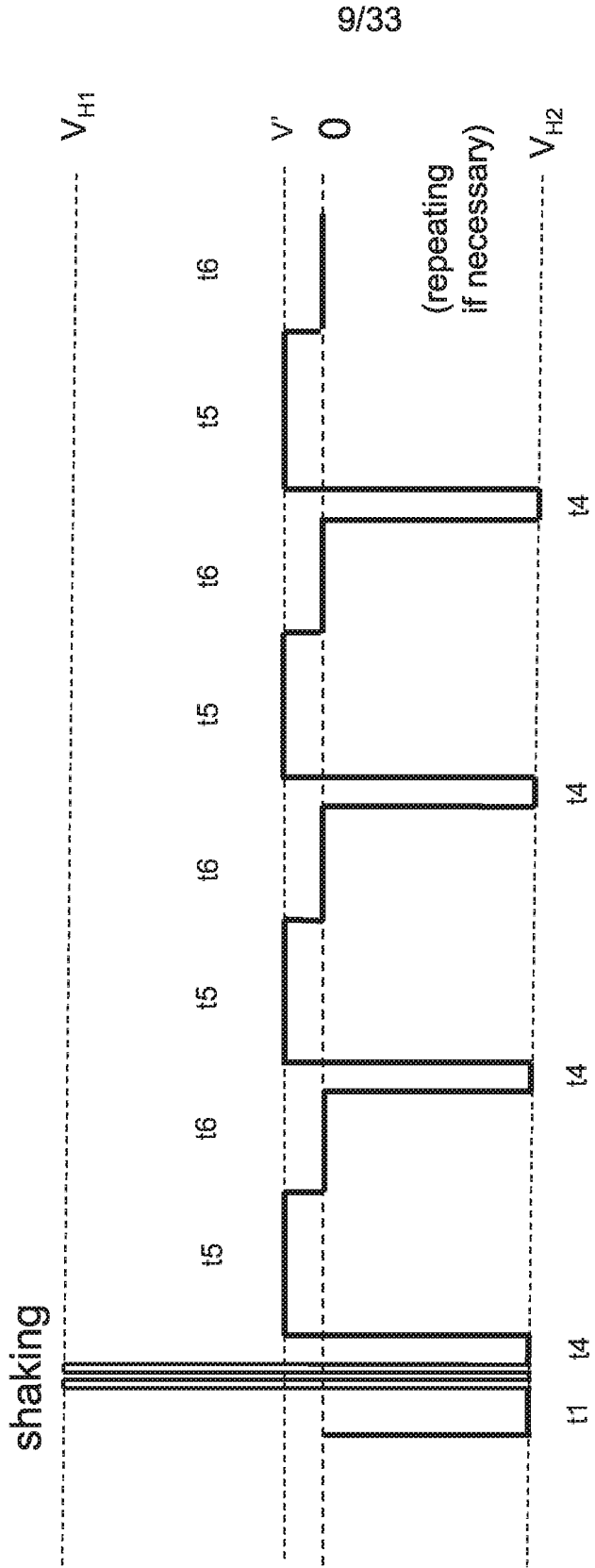

Fig. 9

10/33

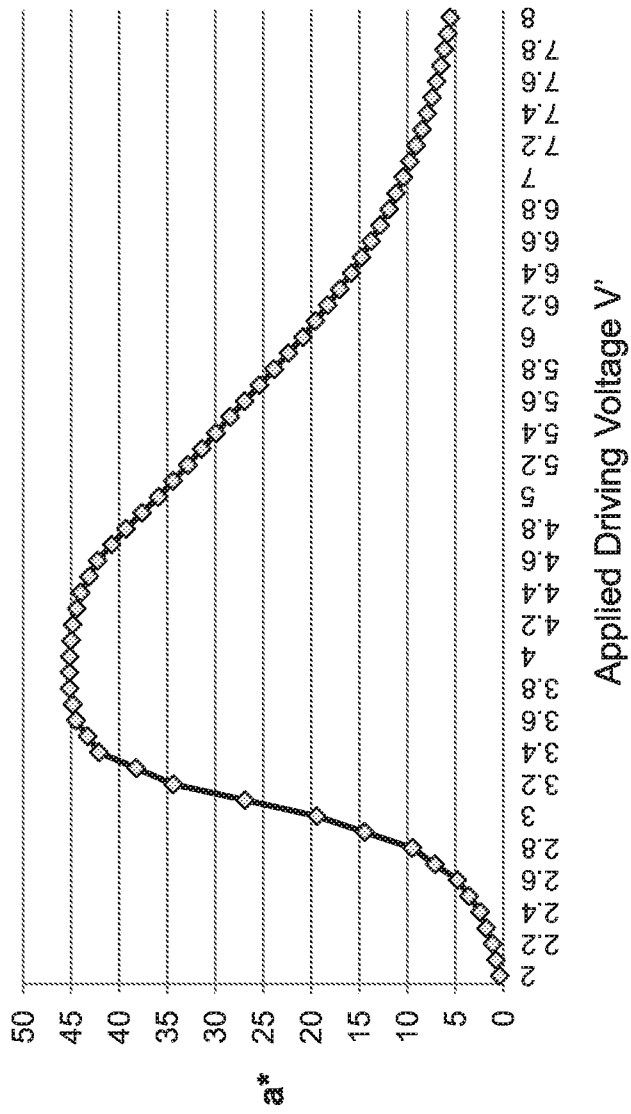

Fig. 10A

11/33

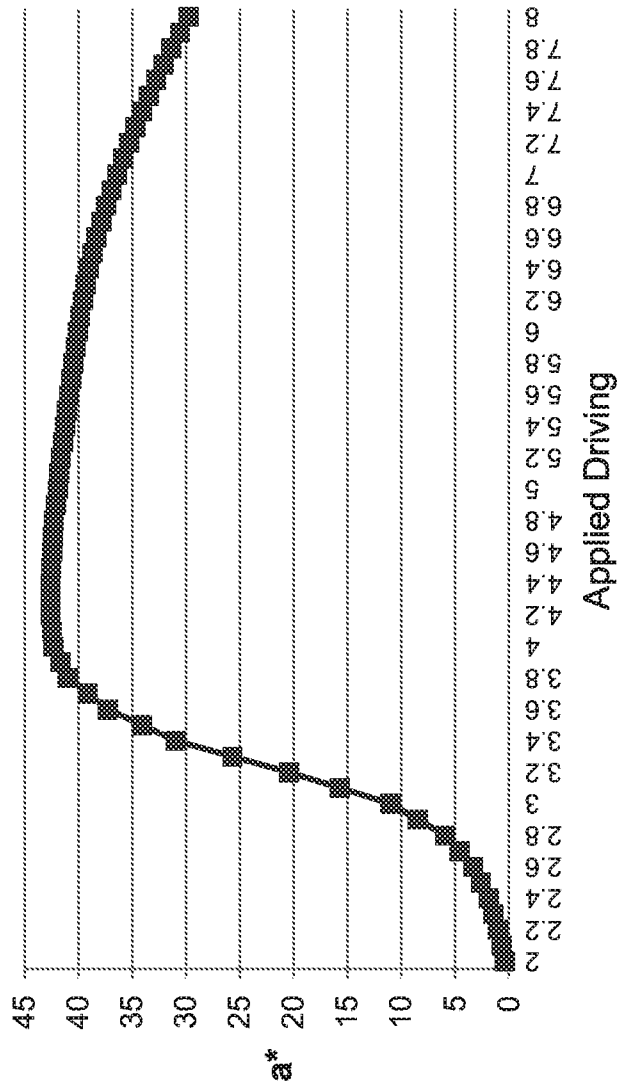

Fig. 10B

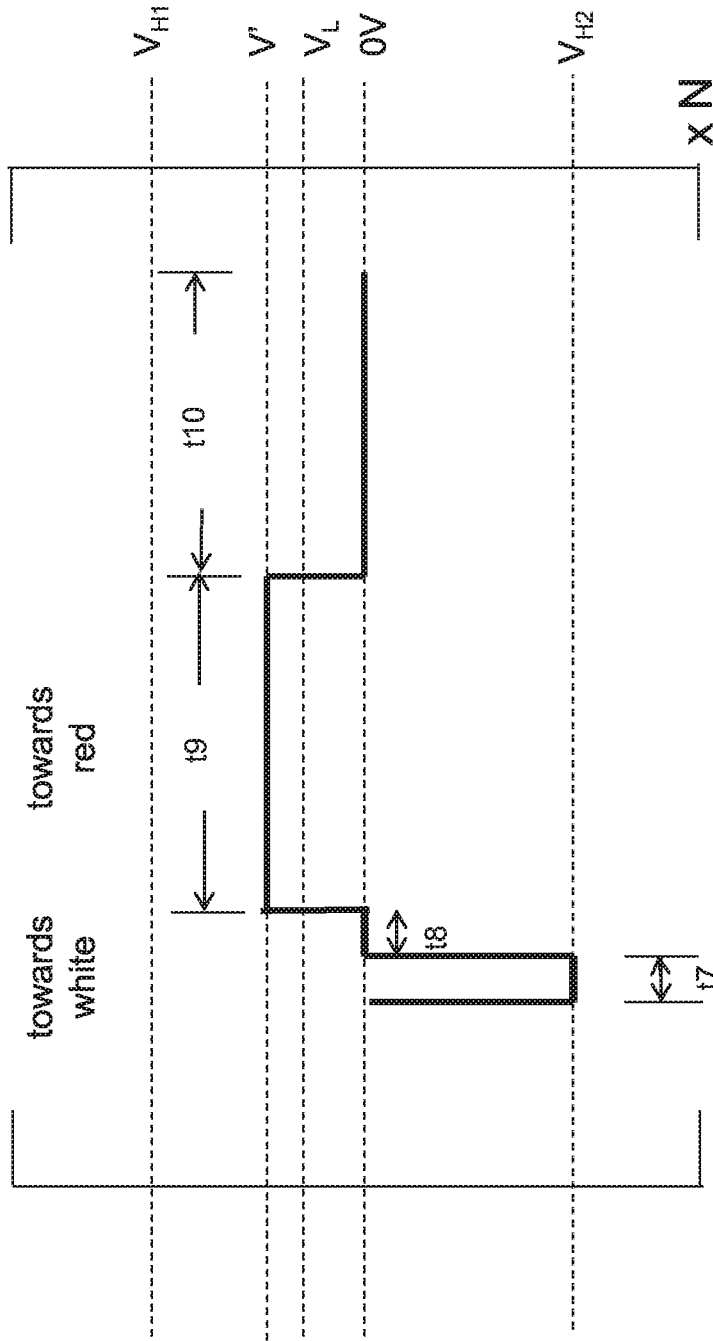

Fig. 11

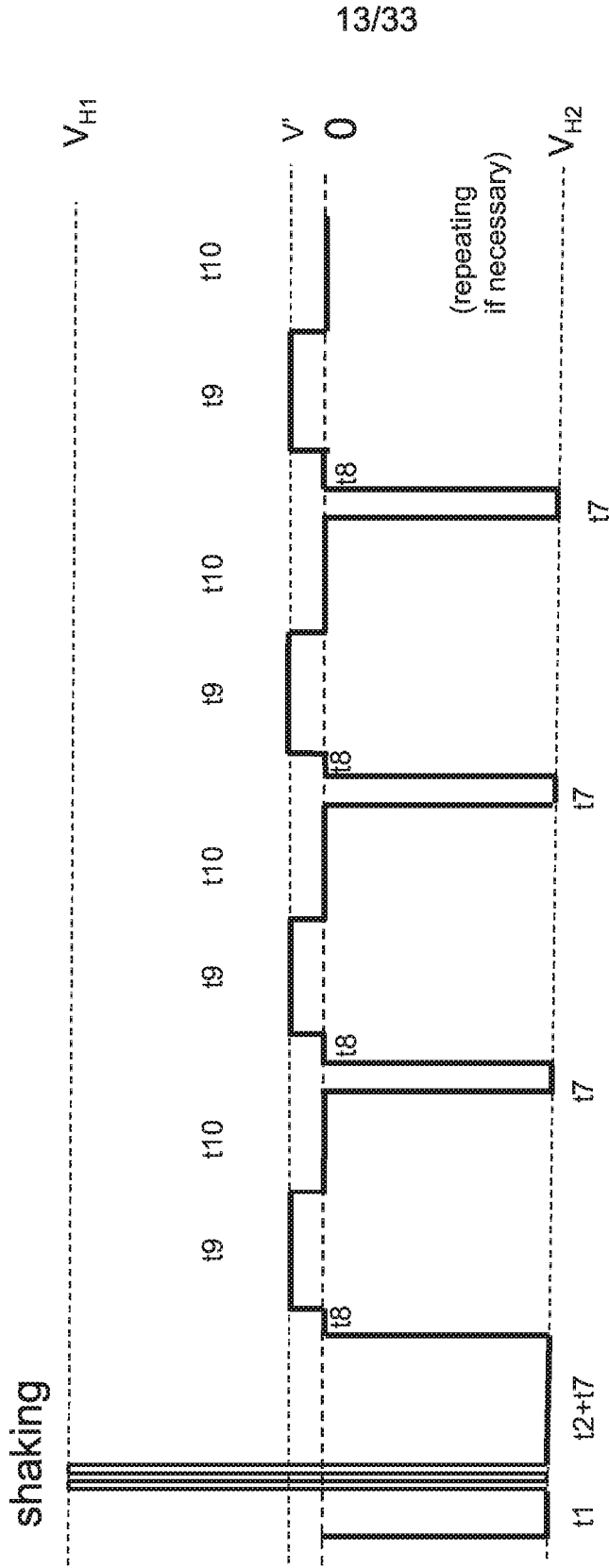

Fig. 12

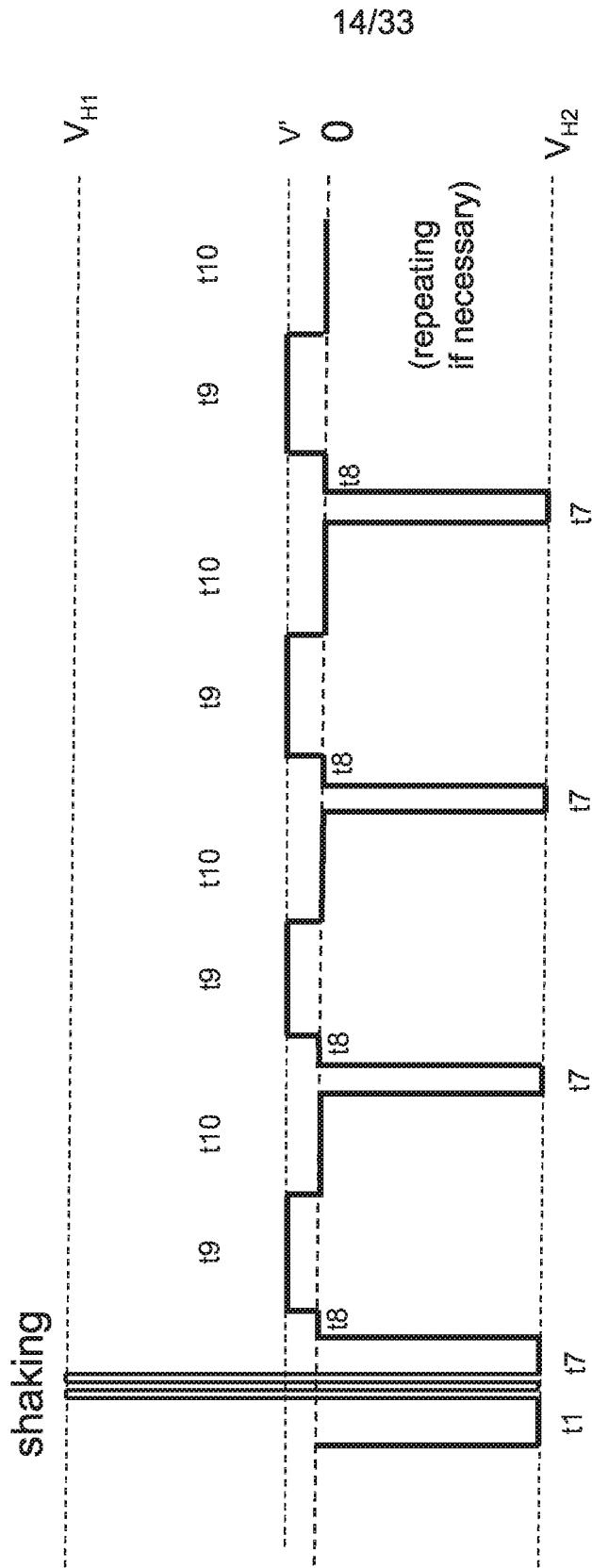

Fig. 13

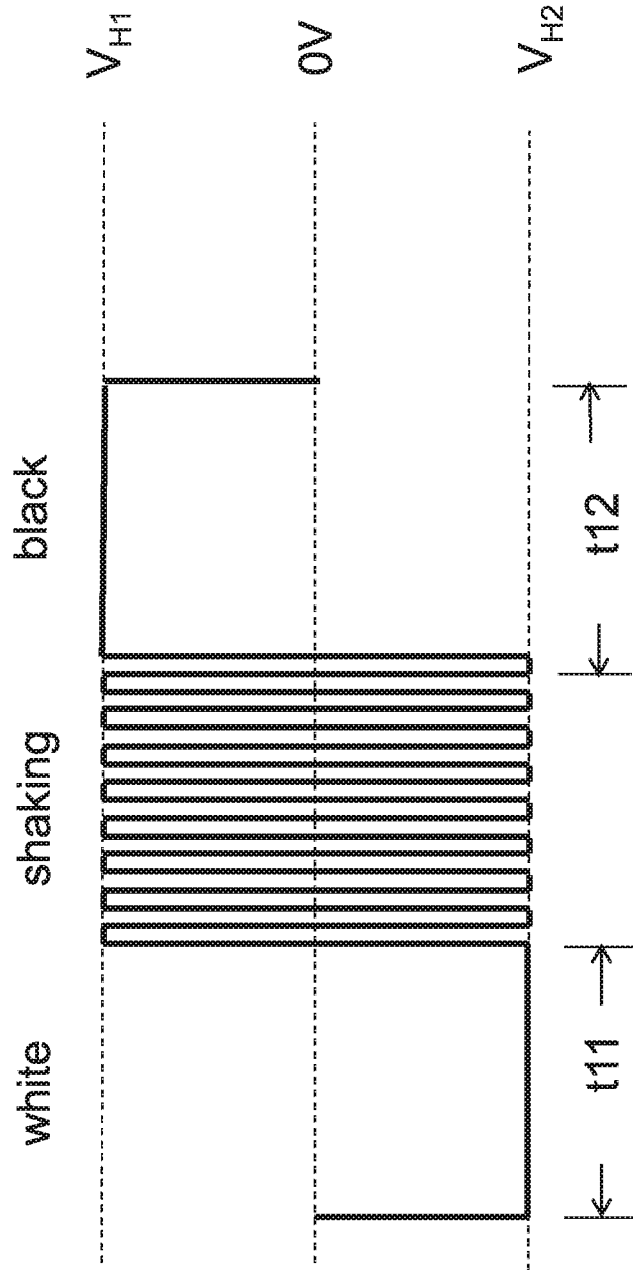

Fig. 14

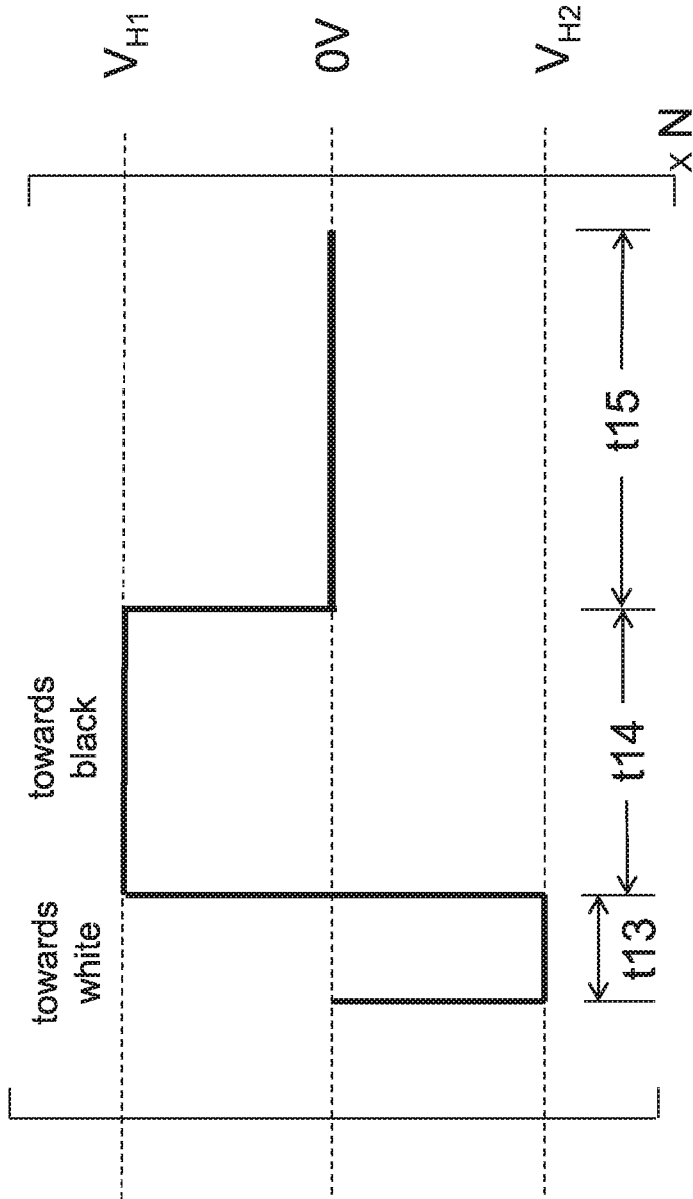

Fig. 15

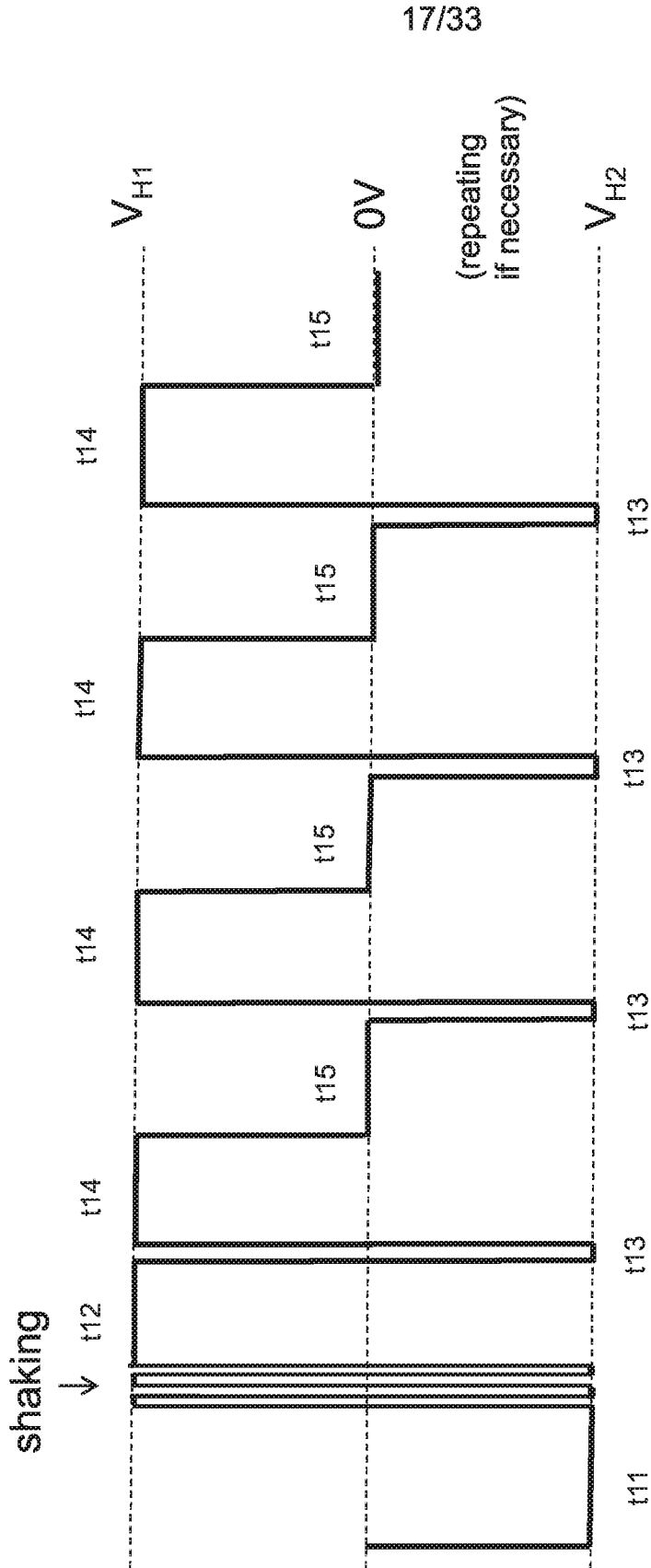

Fig. 16

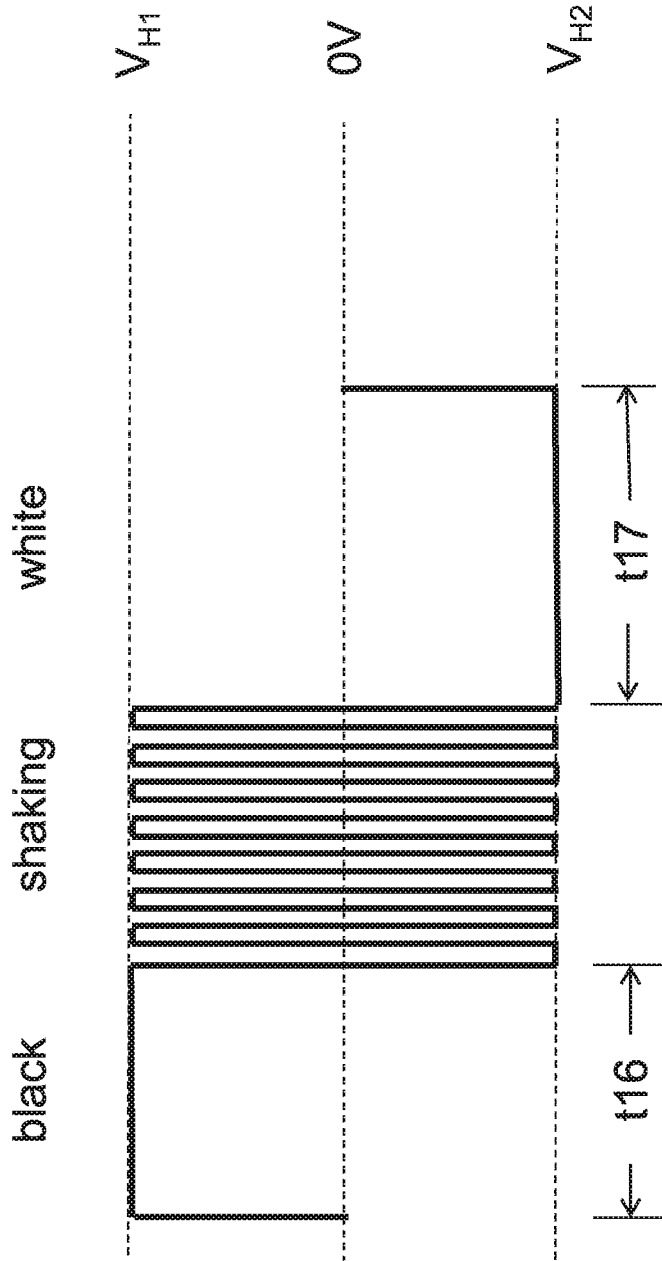

Fig. 17

19/33

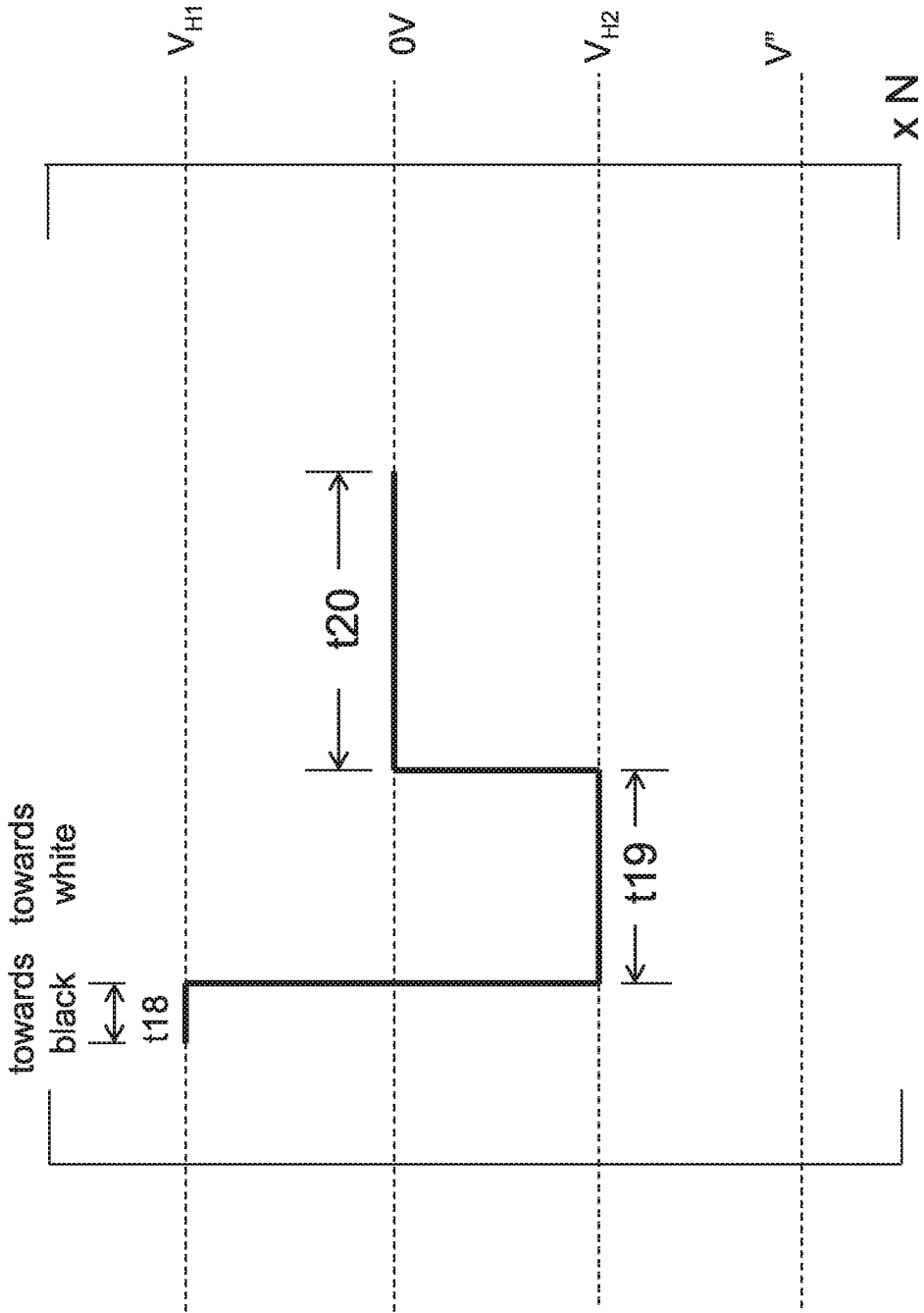

Fig. 18A

20/33

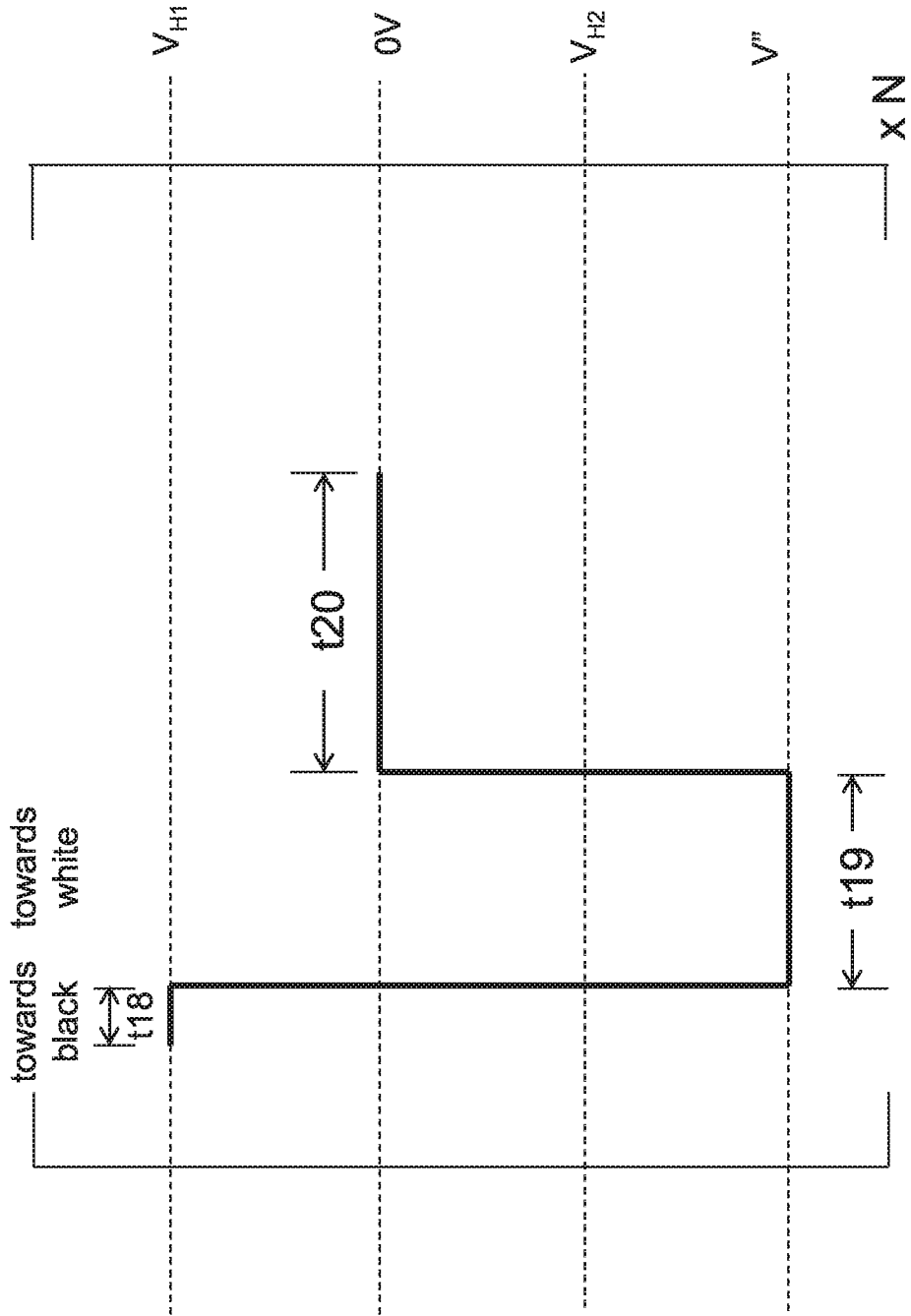

Fig. 18B

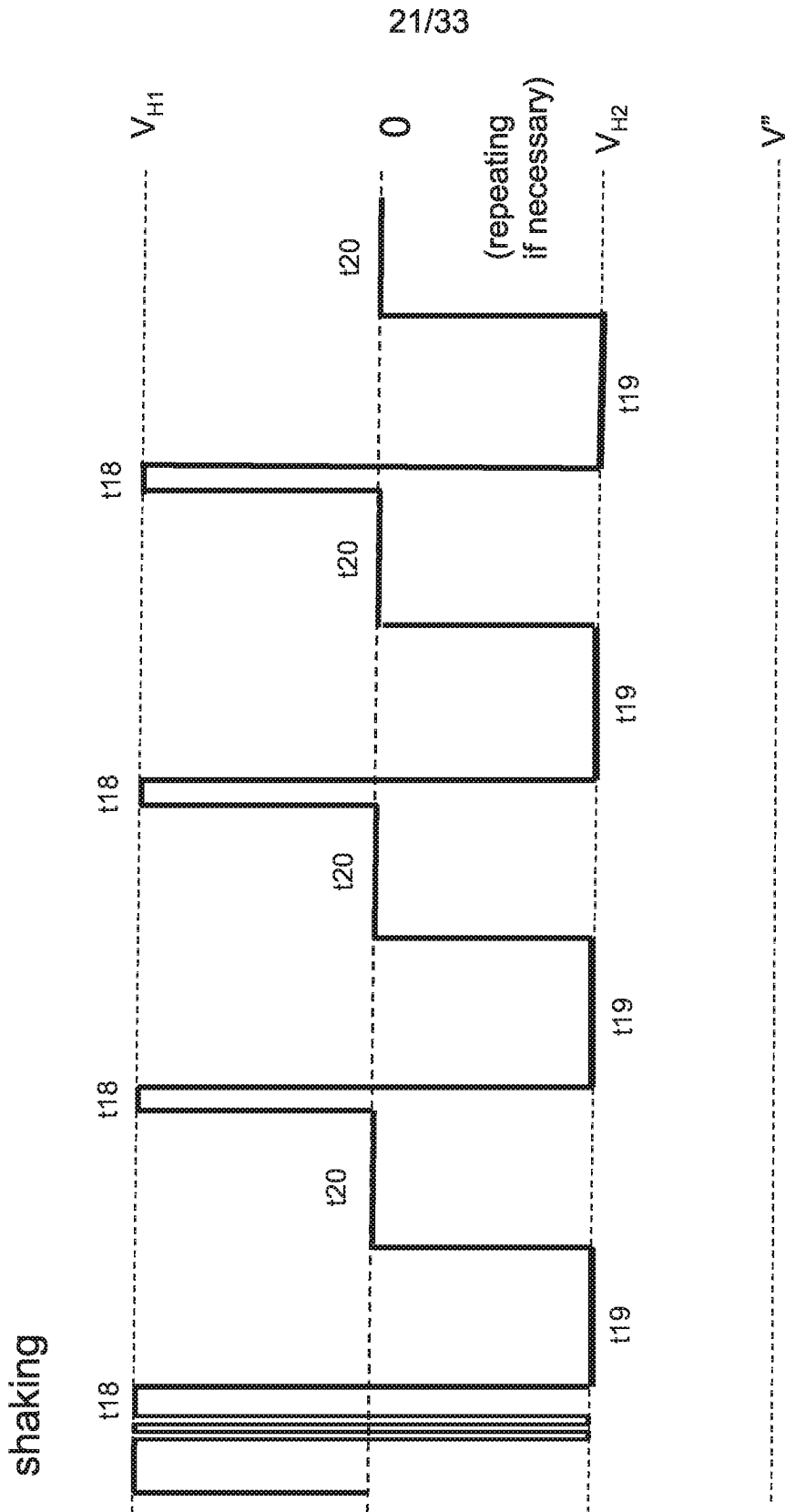

Fig. 19A

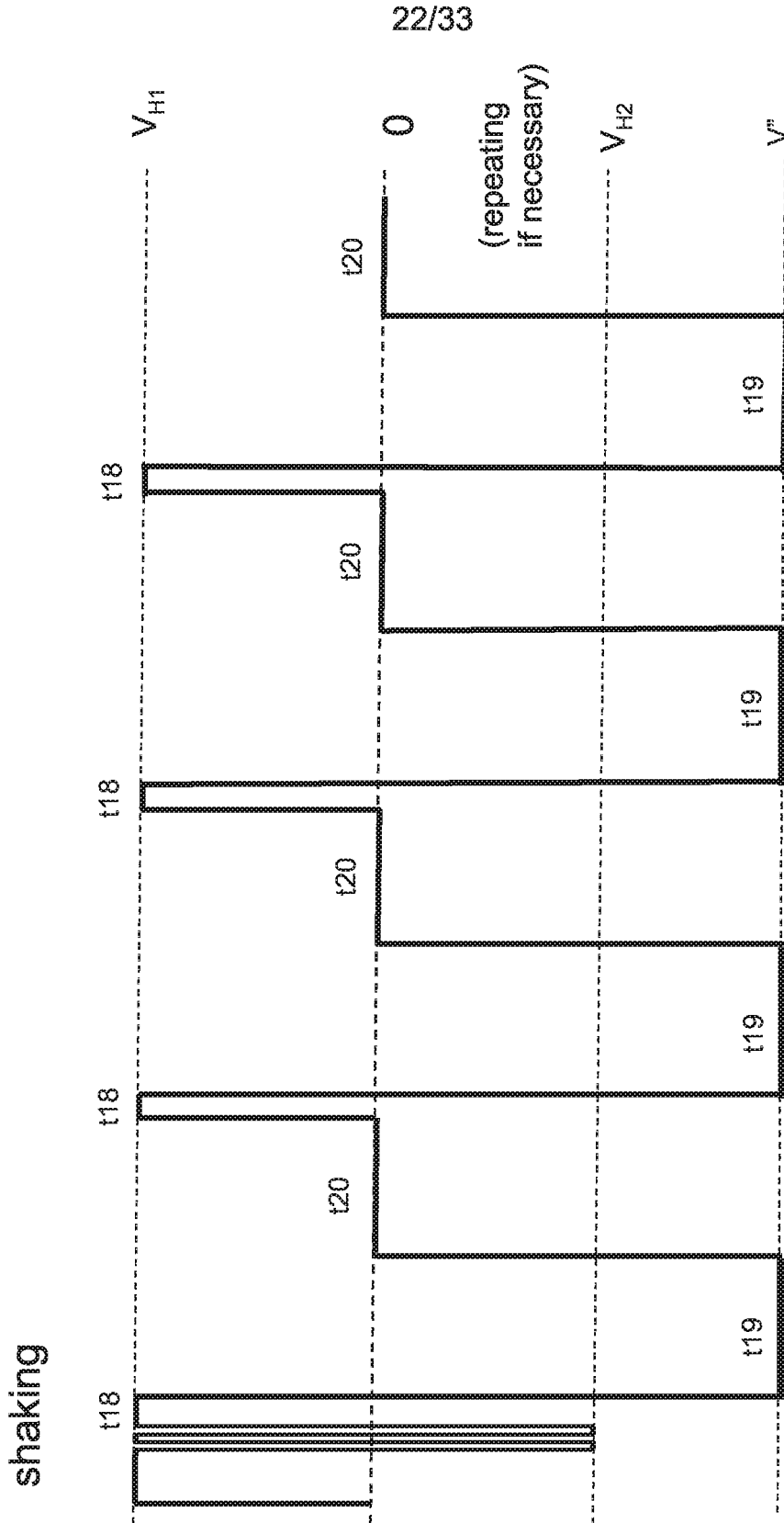

Fig. 19B

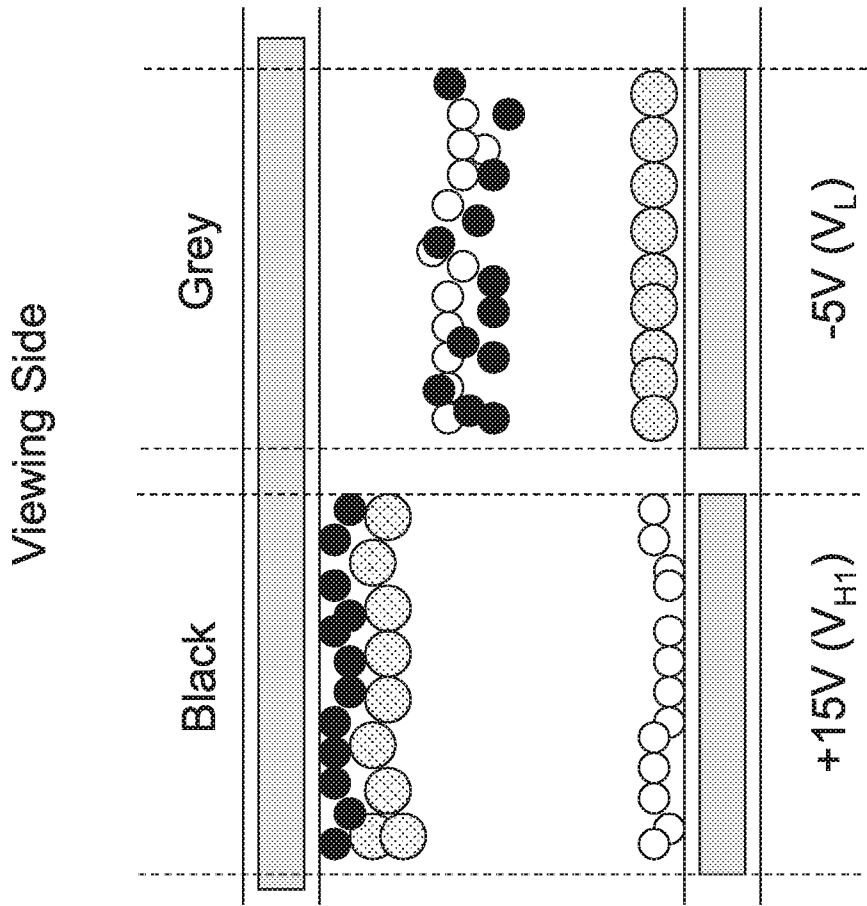

Fig. 20B

Fig. 20A

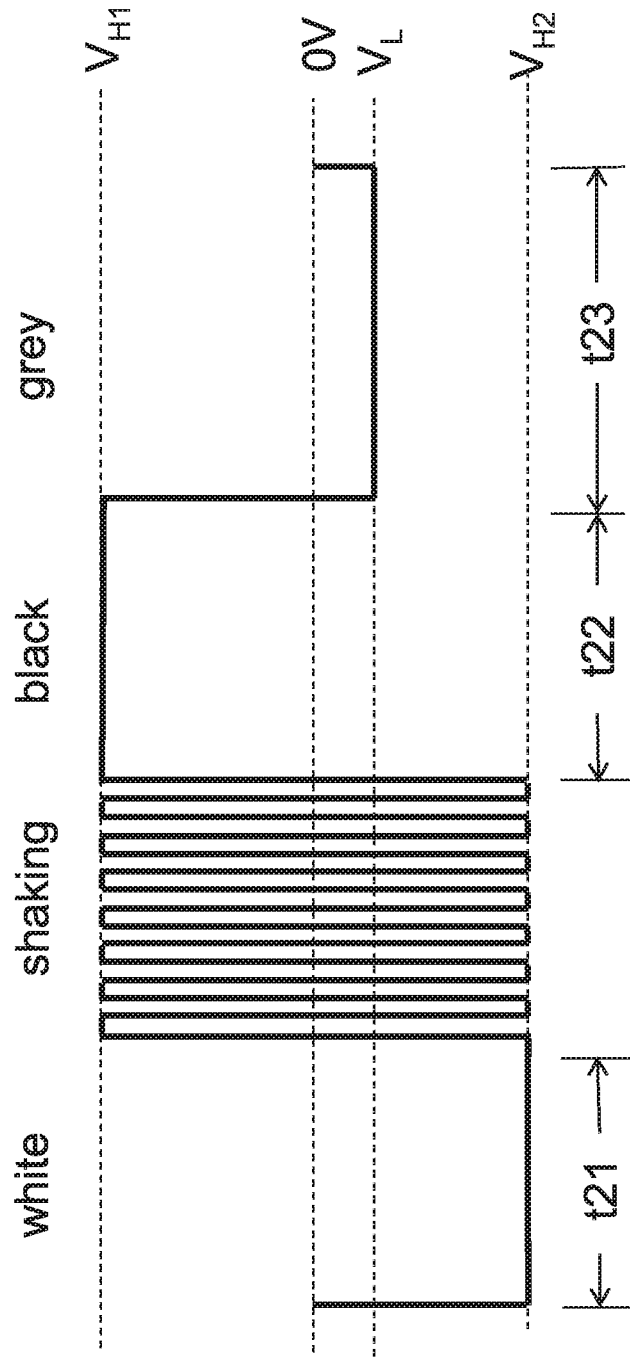

Fig. 21

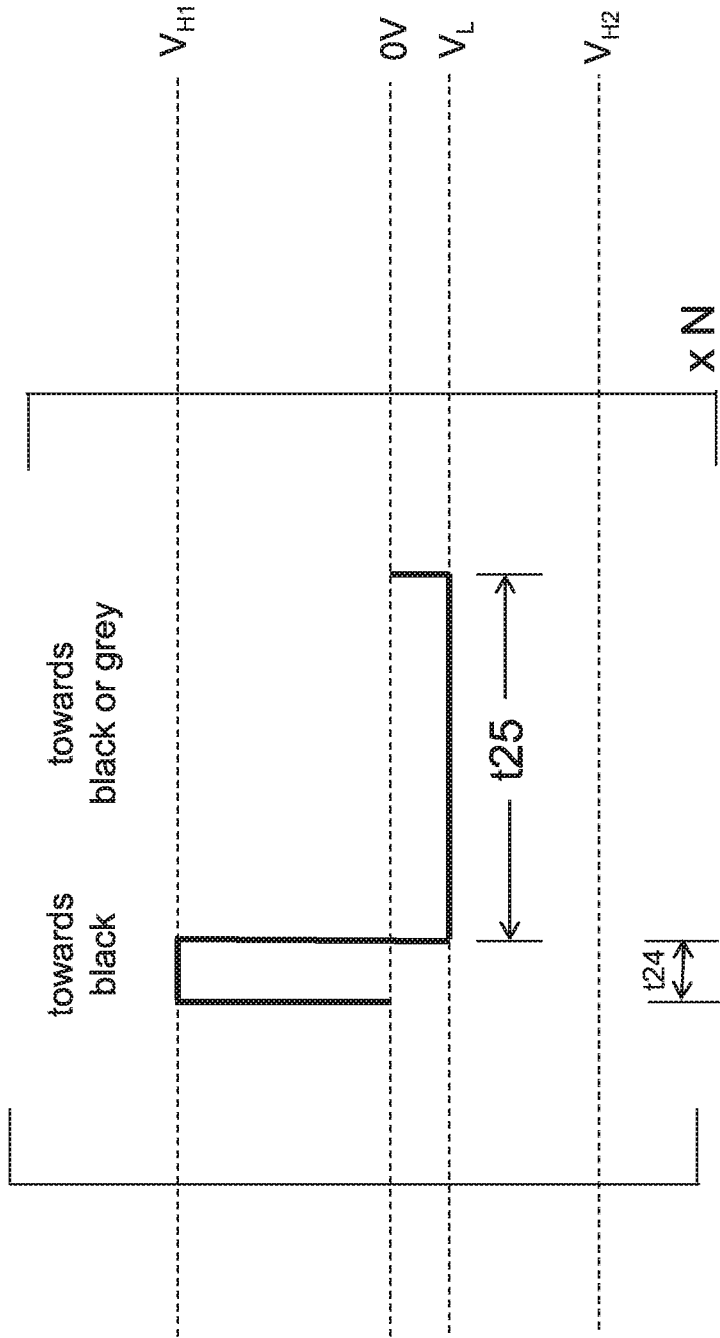

Fig. 22

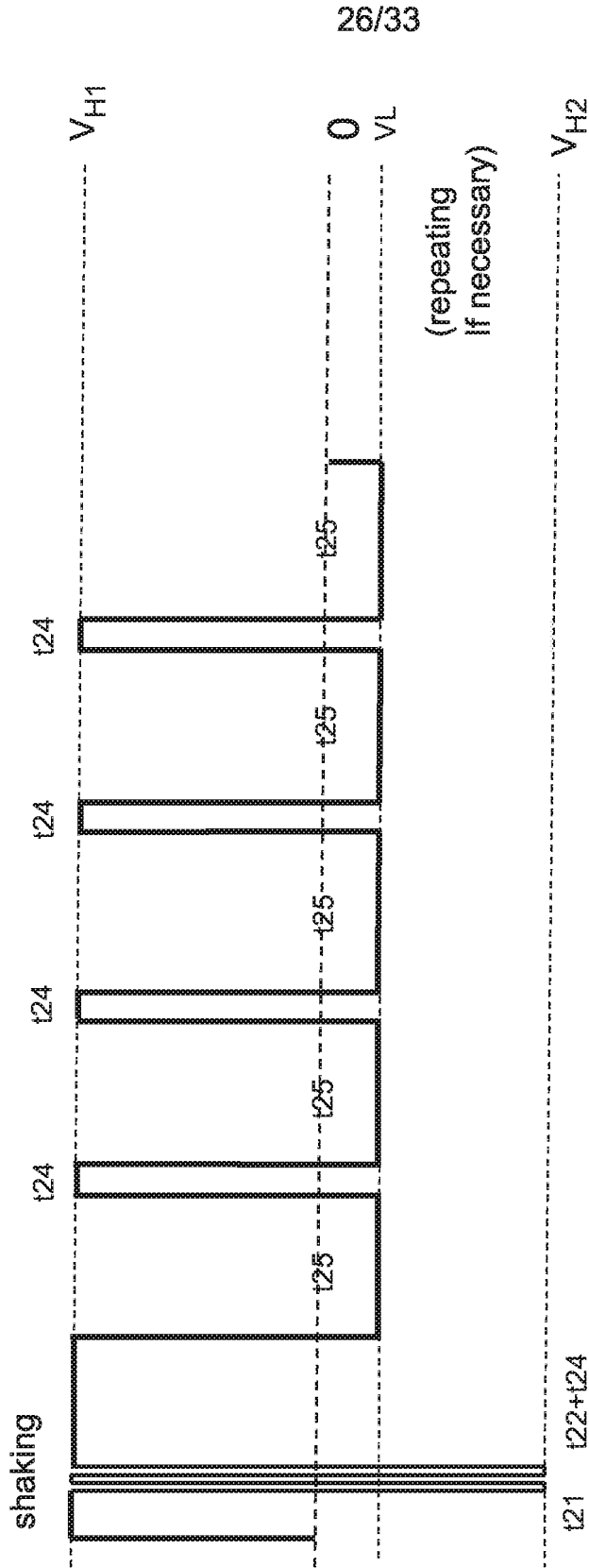

Figure 23

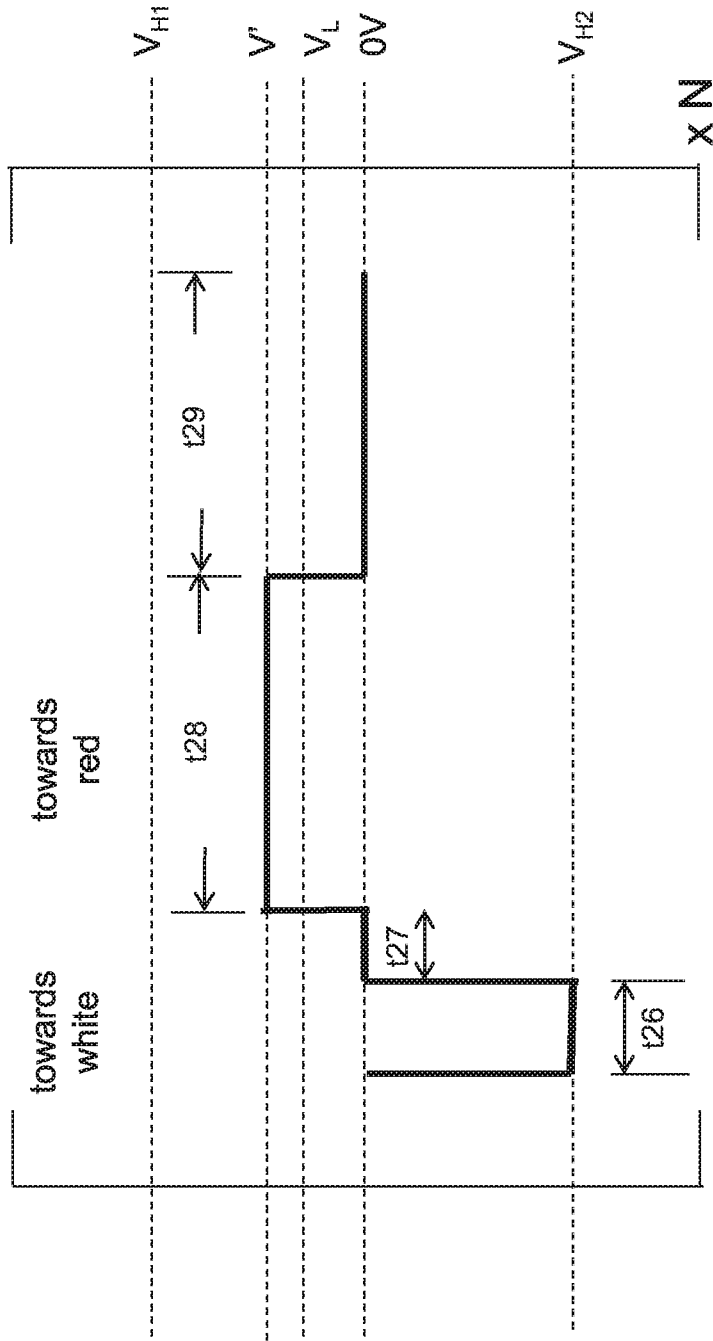

Figure 24

28/33

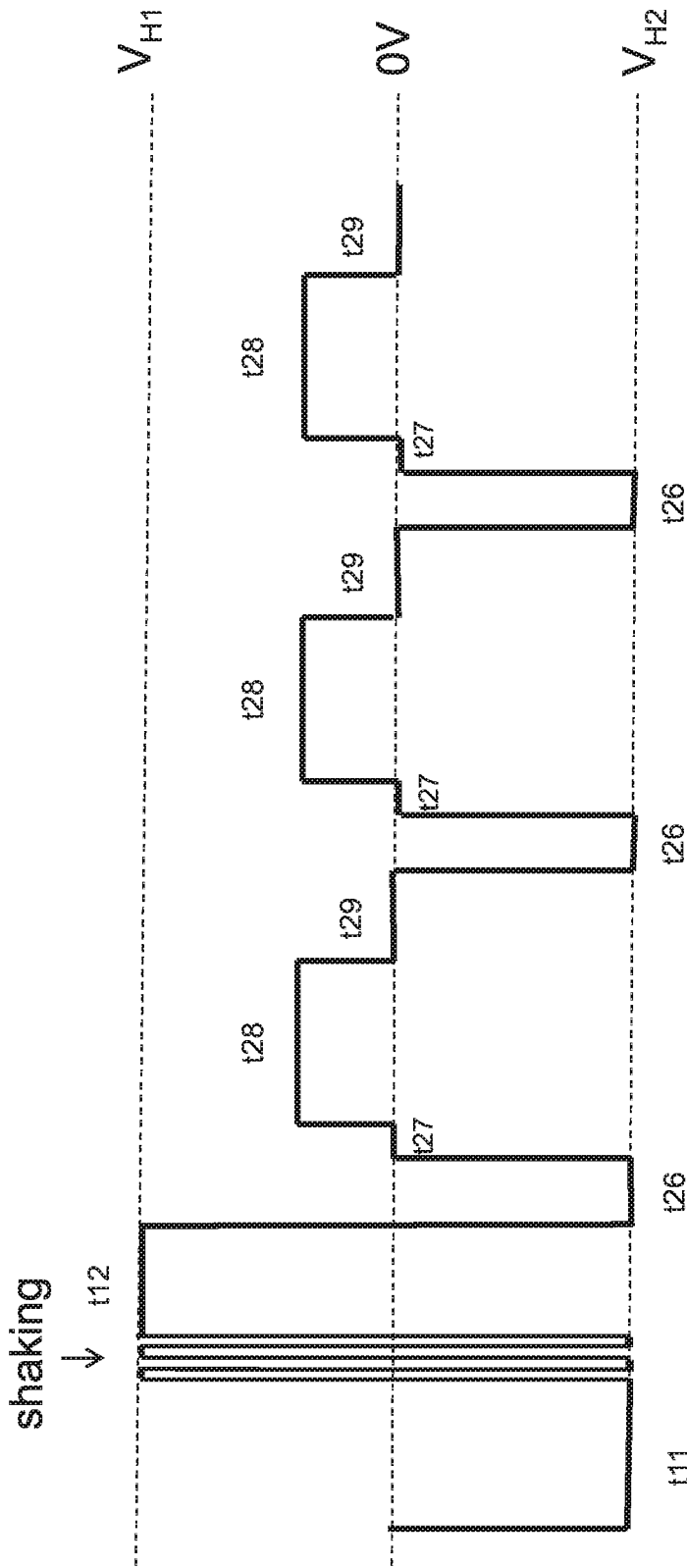

Figure 25

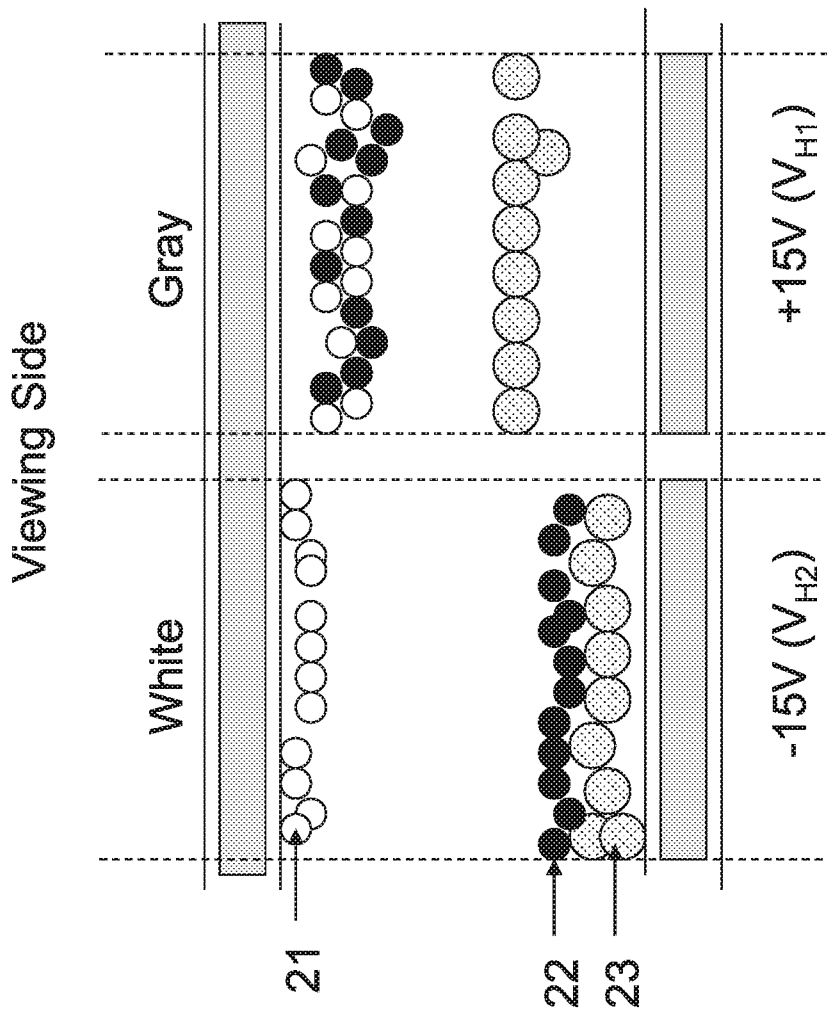

Fig. 26A

Fig. 26B

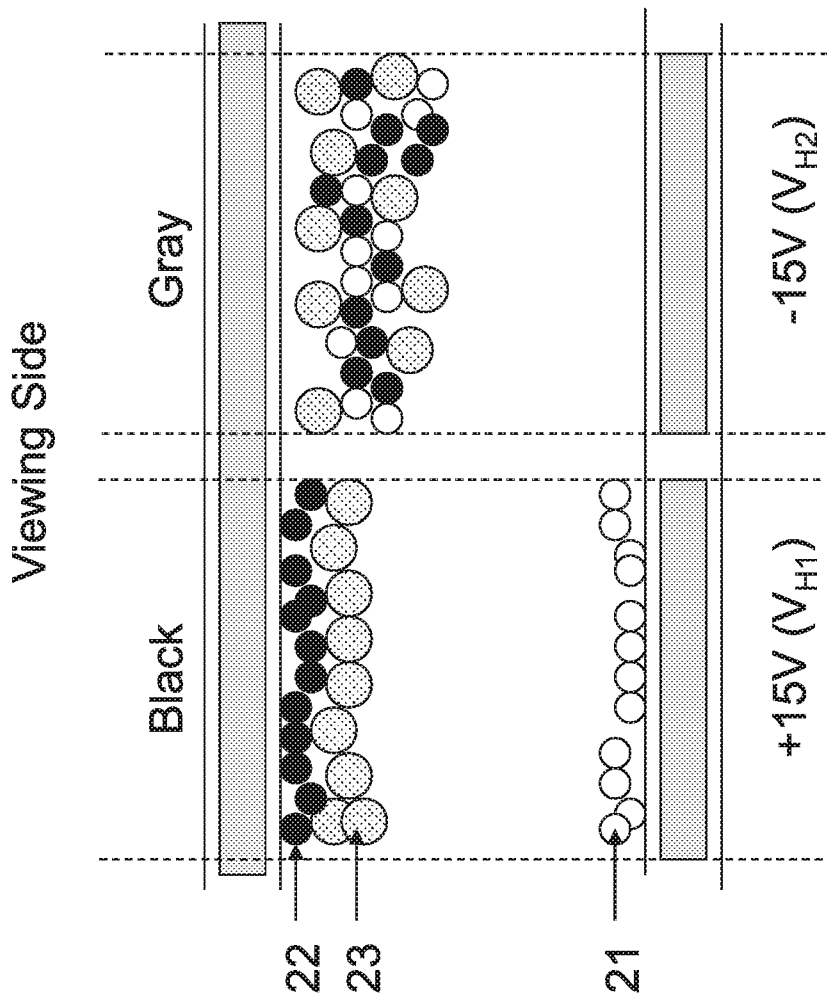

Fig. 26D

Fig. 26C

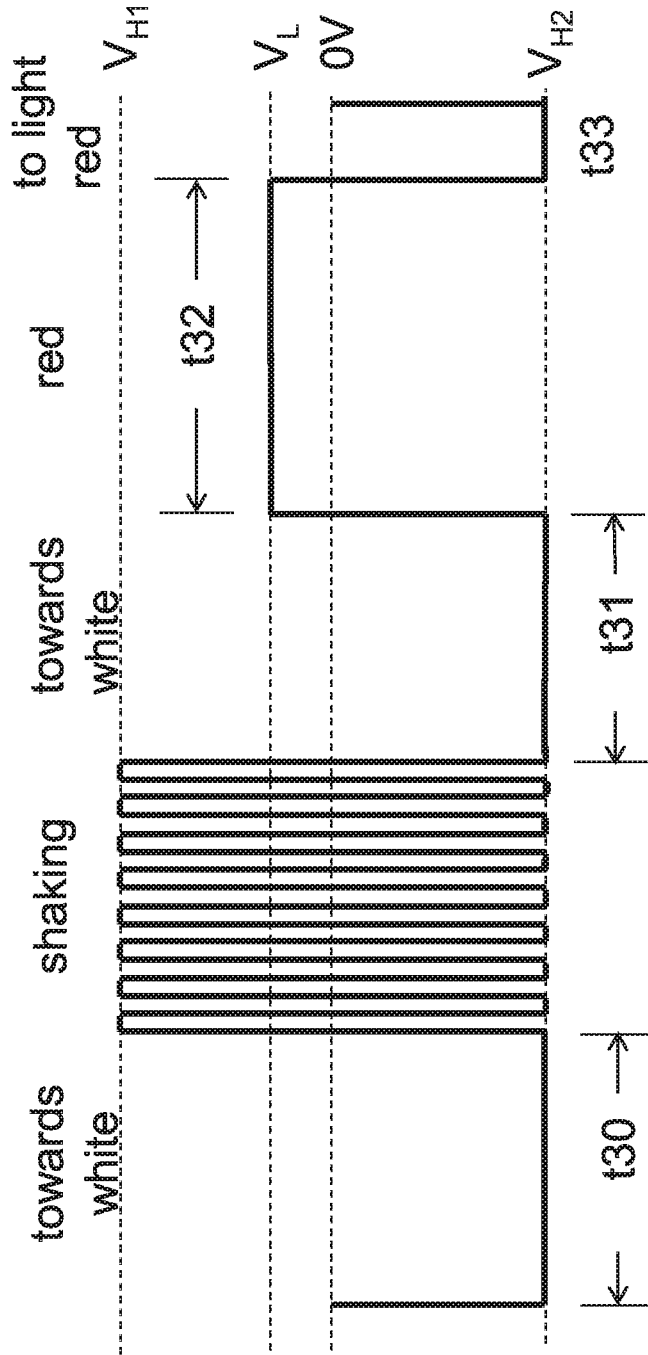

Fig. 27

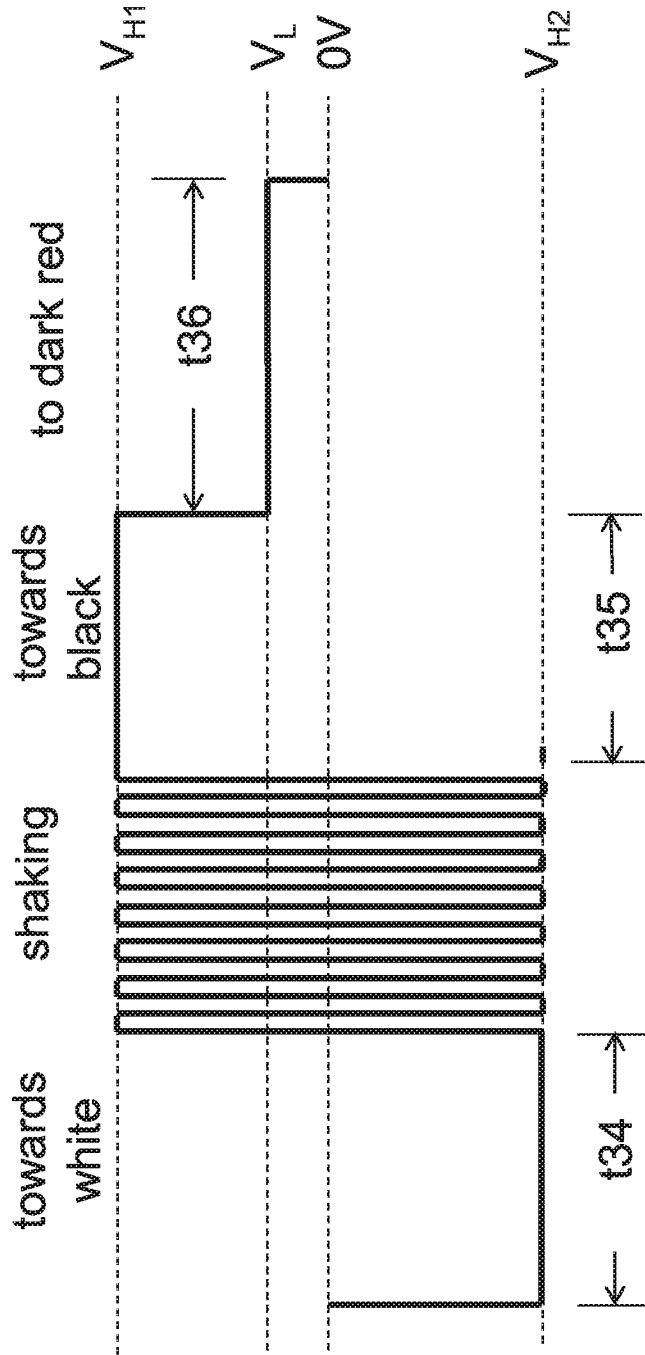

Fig. 28

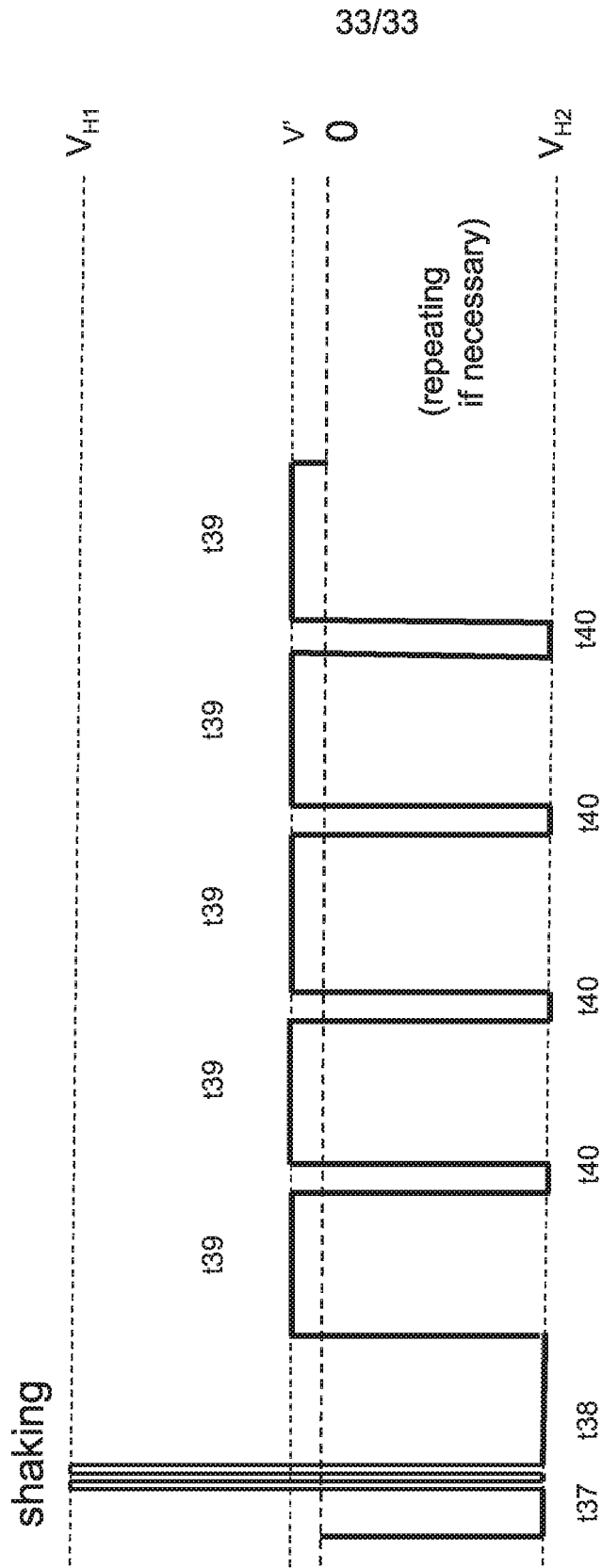

Fig. 29

Viewing Side

