

(19) World Intellectual Property Organization  
International Bureau



(43) International Publication Date  
2 August 2007 (02.08.2007)

PCT

(10) International Publication Number  
**WO 2007/087364 A2**

(51) International Patent Classification:

A61F 2/20 (2006.01) A61L 27/52 (2006.01)  
A61F 2/44 (2006.01)

Georgia 30319 (US). **KU, David N.** [US/US]; 1943 Grist Stone Court, Atlanta, Georgia 30307 (US).

(21) International Application Number:

PCT/US2007/001929

(74) Agent: **RICHARSON, Julie, H.**; MYERS BIGEL SIBLEY & SAJOVEC, P.A., P.O. Box 37428, Raleigh, North Carolina 27627 (US).

(22) International Filing Date: 25 January 2007 (25.01.2007)

(81) Designated States (unless otherwise indicated, for every kind of national protection available): AE, AG, AL, AM, AT, AU, AZ, BA, BB, BG, BR, BW, BY, BZ, CA, CH, CN, CO, CR, CU, CZ, DE, DK, DM, DZ, EC, EE, EG, ES, FI, GB, GD, GE, GH, GM, GT, HN, HR, HU, ID, IL, IN, IS, JP, KE, KG, KM, KN, KP, KR, KZ, LA, LC, LK, LR, LS, LT, LU, LV, LY, MA, MD, MG, MK, MN, MW, MX, MY, MZ, NA, NG, NI, NO, NZ, OM, PG, PH, PL, PT, RO, RS, RU, SC, SD, SE, SG, SK, SL, SM, SV, SY, TJ, TM, TN, TR, TT, TZ, UA, UG, US, UZ, VC, VN, ZA, ZM, ZW.

(25) Filing Language: English

(26) Publication Language: English

(30) Priority Data:

60/761,903 25 January 2006 (25.01.2006) US  
60/821,182 2 August 2006 (02.08.2006) US  
11/626,405 24 January 2007 (24.01.2007) US

(71) Applicant (for all designated States except US): **SALUMEDICA, LLC** [US/US]; 112 Krog Street, Suite 5, Atlanta, Georgia 30307 (US).

(72) Inventors; and

(75) Inventors/Applicants (for US only): **DENOZIERE, Guilhem** [FR/US]; 1913 Brookhaven Circle, Atlanta,

(84) Designated States (unless otherwise indicated, for every kind of regional protection available): ARIPO (BW, GH, GM, KE, LS, MW, MZ, NA, SD, SL, SZ, TZ, UG, ZM, ZW), Eurasian (AM, AZ, BY, KG, KZ, MD, RU, TJ, TM), European (AT, BE, BG, CH, CY, CZ, DE, DK, EE, ES, FI,

[Continued on next page]

(54) Title: METHODS OF PRODUCING PVA HYDROGEL IMPLANTS AND RELATED DEVICES

(57) Abstract: Methods of fabricating elastomeric implants employ a mold with PVA crystals and irrigant added to the mold independent of each other. Related molds are also described.

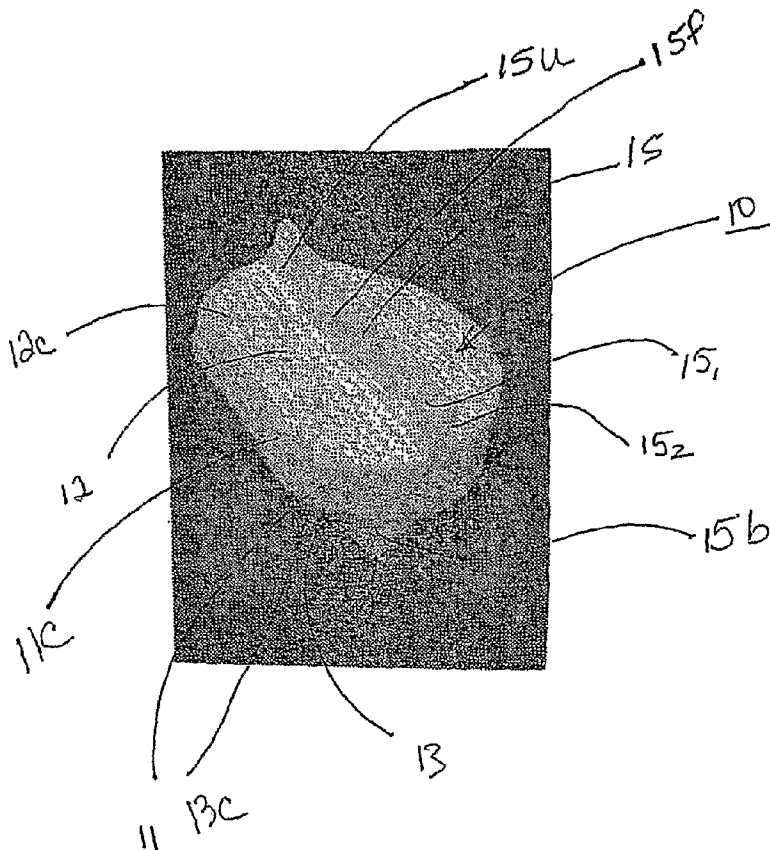

WO 2007/087364 A2



FR, GB, GR, HU, IE, IS, IT, LT, LU, LV, MC, NL, PL, PT,  
RO, SE, SI, SK, TR), OAPI (BF, BJ, CF, CG, CI, CM, GA,  
GN, GQ, GW, ML, MR, NE, SN, TD, TG).

*For two-letter codes and other abbreviations, refer to the "Guidance Notes on Codes and Abbreviations" appearing at the beginning of each regular issue of the PCT Gazette.*

**Published:**

- *without international search report and to be republished upon receipt of that report*

## METHODS OF PRODUCING PVA HYDROGEL IMPLANTS AND RELATED DEVICES

### RELATED APPLICATIONS

[0001] This application claims priority to United States Provisional Application Serial No. 60/761,903, filed January 25, 2006 and United States Provisional Application Serial No. 60/821,182, filed August 2, 2006, the entire contents of the above-referenced documents are hereby incorporated herein by reference as if recited in full herein.

### FIELD OF THE INVENTION

[0002] The invention relates to methods of producing implants and may be particularly relevant to methods of producing spinal implants.

### BACKGROUND OF THE INVENTION

[0003] The vertebrate spine is made of bony structures called vertebral bodies that are separated by relatively soft tissue structures called intervertebral discs. The intervertebral disc is commonly referred to as a spinal disc. The spinal disc primarily serves as a mechanical cushion between the vertebral bones, permitting controlled motions between vertebral segments of the axial skeleton. The disc acts as a joint and allows physiologic degrees of flexion, extension, lateral bending, and axial rotation. The disc must have sufficient flexibility to allow these motions and have sufficient mechanical properties to resist the external forces and torsional moments caused by the vertebral bones.

[0004] The normal disc is a mixed avascular structure having two vertebral end plates ("end plates"), an annulus fibrosis ("annulus") and a nucleus pulposus ("nucleus"). Typically, about 30-50% of the cross sectional area of the disc corresponds to the nucleus. Generally described, the end plates are composed of thin cartilage overlying a thin layer of hard, cortical bone that attaches to the spongy cancellous bone of the vertebral body. The end plates act to attach adjacent vertebrae to the disc.

[0005] The annulus of the disc is a relatively tough, outer fibrous ring. For certain discs, particularly for discs at lower lumbar levels, the annulus can be about 10

to 15 millimeters in height and about 10 to 15 millimeters in thickness, recognizing that cervical discs are smaller.

[0006] Inside the annulus is a gel-like nucleus with high water content. The nucleus acts as a liquid to equalize pressures within the annulus, transmitting the compressive force on the disc into tensile force on the fibers of the annulus. Together, the annulus and nucleus support the spine by flexing with forces produced by the adjacent vertebral bodies during bending, lifting, etc.

[0007] The compressive load on the disc changes with posture. When the human body is supine, the compressive load on the third lumbar disc can be, for example, about 200 Newtons (N), which can rise rather dramatically (for example, to about 800 N) when an upright stance is assumed. The noted load values may vary in different medical references, typically by about +/- 100 to 200 N. The compressive load may increase, yet again, for example, to about 1200 N, when the body is bent forward by only 20 degrees.

[0008] The spinal disc may be displaced or damaged due to trauma or a degenerative process. A disc herniation occurs when the annulus fibers are weakened or torn and the inner material of the nucleus becomes permanently bulged, distended, or extruded out of its normal, internal annular confines. The mass of a herniated or "slipped" nucleus tissue can compress a spinal nerve, resulting in leg pain, loss of muscle strength and control, even paralysis. Alternatively, with discal degeneration, the nucleus loses its water binding ability and deflates with subsequent loss in disc height. Subsequently, the volume of the nucleus decreases, causing the annulus to buckle in areas where the laminated plies are loosely bonded. As these overlapping plies of the annulus buckle and separate, either circumferential or radial annular tears may occur, potentially resulting in persistent and disabling back pain. Adjacent, ancillary facet joints will also be forced into an overriding position, which may cause additional back pain. The most frequent site of occurrence of a herniated disc is in the lower lumbar region. The cervical spinal disks are also commonly affected.

[0009] There are several types of treatment currently being used for treating herniated or degenerated discs: conservative care, discectomy, nucleus replacement, fusion and prosthesis total disc replacement (TDR). It is believed that many patients with lower back pain will get better with conservative treatment of bed rest. For others, more aggressive treatments may be desirable.

[0010] Discectomy can provide good short-term results. However, a discectomy is typically not desirable from a long-term biomechanical point of view. Whenever the disc is herniated or removed by surgery, the disc space will narrow and may lose much of its normal stability. The disc height loss may cause osteo-arthritis changes in the facet joints and/or compression of nerve roots over time. The normal flexibility of the joint is lost, creating higher stresses in adjacent discs. At times, it may be necessary to restore normal disc height after the damaged disc has collapsed.

[0011] Fusion is a treatment by which two vertebral bodies are fixed to each other by a scaffold. The scaffold may be a rigid piece of metal, often including screws and plates, or allo or auto grafts. Current treatment is to maintain disc space by placement of rigid metal devices and bone chips that fuse two vertebral bodies. The devices are similar to mending plates with screws to fix one vertebral body to another one. Alternatively, hollow metal cylinders filled with bone chips can be placed in the intervertebral space to fuse the vertebral bodies together (*e.g.*, LT-Cage™ from Sofamor-Danek or Lumbar I/F CAGE™ from DePuy). These devices have disadvantages to the patient in that the bones are fused into a rigid mass with limited, if any, flexible motion or shock absorption that would normally occur with a natural spinal disc. Fusion may generally eliminate symptoms of pain and stabilize the joint. However, because the fused segment is fixed, the range of motion and forces on the adjoining vertebral discs can be increased, possibly enhancing their degenerative processes.

[0012] Some recent TDR devices have attempted to allow for motion between the vertebral bodies through articulating implants that allow some relative slippage between parts (*e.g.*, ProDisc®, Charite™), see, for example, U.S. Patents 5,314,477, 4,759,766, 5,401,269 and 5,556,431. As an alternative to the metallic-plate, multi-component TDR (total disc replacement) designs, a flexible solid elastomeric spinal disc implant that is configured to simulate natural disc action (*i.e.*, can provide shock absorption and elastic tensile and compressive deformation) is described in U.S. Patent Application Publication No. 2005/0055099 to Ku, the contents of which are hereby incorporated by reference as if recited in full herein.

#### SUMMARY OF EMBODIMENTS OF THE INVENTION

[0013] Embodiments of the invention are directed to methods of fabricating flexible implants and/or molds therefor.

[0014] Some embodiments are directed to medical (typically implant) fabrication molds. The molds include: (a) a mold having a three-dimensionally shaped mold cavity with an upstanding sidewall, with a releasably attachable floor and ceiling; (b) at least one mesh layer disposed in the mold cavity; and (c) a quantity of polyvinyl alcohol material and irrigation fluid disposed in the mold cavity over the at least one mesh layer to form a hydrogel implant body, such that, during exposure to heat, the at least one mesh layer integrally attaches to the hydrogel implant body to define a molded medical device (such, as for example, but not limited to, an implantable TDR spinal disc prosthesis).

[0015] Some embodiments of the present invention are directed to methods of fabricating medical implants (which can be 2-D or 3-D bodies). The methods include: (a) introducing a quantity of PVA material into a mold cavity; (b) inserting a quantity of saline over the PVA; (c) placing a lid on the mold to place the cavity with the PVA and saline under pressure; (d) heating the mold for a desired time and temperature so that the PVA and saline reach a desired temperature and form a molded body; (e) cooling the mold with the molded body after the heating step; and (f) forming a medical PVA hydrogel implant.

[0016] Some embodiments are directed to methods of fabricating an implantable prosthesis. The methods include: (a) placing an inferior mesh layer on a floor of a three-dimensional mold; (b) introducing moldable material into the mold; (c) placing a superior mesh layer on a top surface of the moldable material in the mold; (d) closing the mold; (e) pushing any excess moldable material out of the mold in response to the closing step; and (f) heating the mold with the moldable material to a desired temperature so that the mold is heated to at least about 80°C for at least about 5 minutes; then (g) forming a molded implant body formed by the heated moldable material whereby the mesh layers are integrally attached to the molded body formed by the moldable material.

[0017] Other methods of fabricating medical implants include: (a) introducing a quantity of PVA material into a mold cavity of a mold; (b) inserting a quantity of saline into the mold cavity independently of the introduction of the PVA; (c) placing a lid on the mold to close the mold cavity with the PVA and saline; (d) heating the mold for a desired time and temperature so that the PVA and saline reach a desired temperature and form a molded body; (e) cooling the mold with the molded body after the heating step; and (f) forming a medical PVA hydrogel implant.

[0018] Still other methods of fabricating medical implants include: (a) placing a lid on a mold to substantially close a mold cavity; (b) introducing a quantity of PVA material into the mold cavity before or after the placing step; (c) inserting a quantity of saline through a vent path extending through the mold lid after the lid is placed on the mold; (d) then sealing the vent path; (e) then heating the mold for a desired time and temperature so that the PVA and saline reach a desired temperature and form a molded body; (f) cooling the mold with the molded body after the heating step; and (g) forming a medical PVA hydrogel implant.

[0019] Further features, advantages and details of the present invention will be appreciated by those of ordinary skill in the art from a reading of the figures and the detailed description of the embodiments that follow, such description being merely illustrative of the present invention.

#### BRIEF DESCRIPTION OF THE DRAWINGS

[0020] **Figure 1** is a top perspective view of implantable spinal disc prosthesis with flexible keels according to embodiments of the present invention.

[0021] **Figure 2** is a top perspective view of another implantable spinal disc prosthesis with flexible keels according to embodiments of the present invention.

[0022] **Figure 3** is a front view of the spinal disc prosthesis shown in **Figure 2** in position with the flexible keels in respective receiving mortises formed in adjacent vertebrae according to embodiments of the present invention.

[0023] **Figure 4A** is a front schematic view of another embodiment of a spinal disc implant according to embodiments of the present invention.

[0024] **Figure 4B** is a front schematic view of another embodiment of a spinal disc implant according to embodiments of the present invention.

[0025] **Figures 5A-5C** are cross-sectional views of a keel with reinforcement material according to embodiments of the present invention.

[0026] **Figures 6A-6C** are front or side schematic views of other embodiments of different configurations of flex-keels for a spinal disc implant according to embodiments of the present invention.

[0027] **Figure 7** is a front or side schematic view of another embodiment of a spinal disc implant according to embodiments of the present invention.

[0028] **Figure 8** is a schematic front or side view of another embodiment of a spinal disc implant according to embodiments of the present invention.

[0029] **Figure 9** is a schematic top view of another embodiment of a spinal disc implant according to embodiments of the present invention.

[0030] **Figure 10A** is a schematic side or front view of yet another embodiment of a spinal disc implant according to embodiments of the present invention.

[0031] **Figure 10B** is a side perspective view of yet another spinal disc implant according to embodiments of the present invention.

[0032] **Figures 11A and 11B** are cross-sectional schematic illustrations of implants with keels and subsurface attachment segments according to embodiments of the present invention.

[0033] **Figure 12** is a flow chart of operations that can be used to fabricate a flexible keel spinal disc implant according to embodiments of the present invention.

[0034] **Figure 13A** is a schematic illustration of a spinal disc implant mold configured to receive moldable implant material to form a spinal disc implant according to embodiments of the present invention.

[0035] **Figure 13B** is a schematic illustration of the mold shown in **Figure 13A** with a lid thereon.

[0036] **Figure 14** is a schematic illustration of a three-piece outer covering that can be integrally attached to a molded elastomeric body according to embodiments of the present invention.

[0037] **Figure 15** is a schematic illustration of a semi-automated assembly line that can be used to fabricate spinal disc implants according to embodiments of the present invention.

[0038] **Figure 16A** is a cross-sectional view of a spinal disc implant mold according to embodiments of the present invention.

[0039] **Figure 16B** is a bottom view of a spinal disc implant mold according to embodiments of the present invention.

[0040] **Figure 16C** is a bottom view of a spinal disc implant mold according to embodiments of the present invention.

[0041] **Figures 17A and 17B** are schematic front views of a multi-component mold according to embodiments of the present invention.

[0042] **Figure 18** is an end view of a middle body of a mold according to embodiments of the present invention.



[0043] **Figure 19** is an end view of a lower plate that is attachable to the middle body shown in **Figure 18** according to embodiments of the present invention.

[0044] **Figure 20A** is a top view of a top mold member that is attachable to the middle body shown in **Figure 18** according to embodiments of the present invention.

[0045] **Figure 20B** is a cross-sectional view of the top mold member shown in **Figure 20A** taken along line **20B-20B**.

[0046] **Figure 21A** is a bottom view of a bottom mold member receivable in the middle member shown in **Figure 18** according to embodiments of the present invention.

[0047] **Figure 21B** is a cross-sectional view of the bottom mold member shown in **Figure 21A** taken along lines **21B-21B**.

[0048] **Figure 22** is a flow chart of operations that can be used to fabricate surgical implants according to embodiments of the present invention.

#### DETAILED DESCRIPTION

[0049] The present invention now is described more fully hereinafter with reference to the accompanying drawings, in which embodiments of the invention are shown. This invention may, however, be embodied in many different forms and should not be construed as limited to the embodiments set forth herein; rather, these embodiments are provided so that this disclosure will be thorough and complete, and will fully convey the scope of the invention to those skilled in the art.

[0050] Like numbers refer to like elements throughout. In the figures, the thickness of certain lines, layers, components, elements or features may be exaggerated for clarity. Broken lines illustrate optional features or operations unless specified otherwise.

[0051] The terminology used herein is for the purpose of describing particular embodiments only and is not intended to be limiting of the invention. As used herein, the singular forms "a", "an" and "the" are intended to include the plural forms as well, unless the context clearly indicates otherwise. It will be further understood that the terms "comprises" and/or "comprising," when used in this specification, specify the presence of stated features, integers, steps, operations, elements, and/or components, but do not preclude the presence or addition of one or more other features, integers, steps, operations, elements, components, and/or groups

thereof. As used herein, the term "and/or" includes any and all combinations of one or more of the associated listed items. As used herein, phrases such as "between X and Y" and "between about X and Y" should be interpreted to include X and Y. As used herein, phrases such as "between about X and Y" mean "between about X and about Y." As used herein, phrases such as "from about X to Y" mean "from about X to about Y."

**[0052]** Unless otherwise defined, all terms (including technical and scientific terms) used herein have the same meaning as commonly understood by one of ordinary skill in the art to which this invention belongs. It will be further understood that terms, such as those defined in commonly used dictionaries, should be interpreted as having a meaning that is consistent with their meaning in the context of the specification and relevant art and should not be interpreted in an idealized or overly formal sense unless expressly so defined herein. Well-known functions or constructions may not be described in detail for brevity and/or clarity.

**[0053]** It will be understood that when an element is referred to as being "on", "attached" to, "connected" to, "coupled" with, "contacting", etc., another element, it can be directly on, attached to, connected to, coupled with or contacting the other element or intervening elements may also be present. In contrast, when an element is referred to as being, for example, "directly on", "directly attached" to, "directly connected" to, "directly coupled" with or "directly contacting" another element, there are no intervening elements present. It will also be appreciated by those of skill in the art that references to a structure or feature that is disposed "adjacent" another feature may have portions that overlap or underlie the adjacent feature..

**[0054]** It will be understood that, although the terms first, second, etc. may be used herein to describe various elements, components, regions, layers and/or sections, these elements, components, regions, layers and/or sections should not be limited by these terms. These terms are only used to distinguish one element, component, region, layer or section from another region, layer or section. Thus, a first element, component, region, layer or section discussed below could be termed a second element, component, region, layer or section without departing from the teachings of the present invention. The sequence of operations (or steps) is not limited to the order presented in the claims or figures unless specifically indicated otherwise.

[0055] The terms "spinal disc implant" and "spinal disc prosthesis" are used interchangeably herein to designate total disc replacements using an implantable total spinal disc replacement prosthesis (rather than a nucleus only) and as such are configured to replace the natural spinal disc of a mammalian subject (for veterinary or medical (human) applications). In contrast, the term "spinal implant" refers to both TDR spinal disc implants and alternative spinal implants, such as, for example, a spinal annulus or a spinal nucleus implant.

[0056] The term "flexible" means that the member can be flexed or bent. In some embodiments, the keel is flexible but has sufficient rigidity to be substantially self-supporting so as to be able to substantially maintain a desired configuration outside of the body. The keel can include reinforcement to increase its rigidity.

[0057] The term "keel" means an implant component, feature or member that is configured to be received in a recess or mortise in an adjacent bone to facilitate short and/or long-term fixation and/or to provide twist or torsion resistance *in situ*. The term "keel" also includes a discontinuous keel configuration and/or a keel configuration that does not extend the entire length of the implant body, such as one or more axially aligned or offset keels as shown, for example, in **Figure 10A**.

[0058] The term "mesh" means any biocompatible flexible material in any form including, for example, knotted, braided, extruded, stamped, knitted, woven or otherwise, and may include a material with a substantially regular pore or foramination pattern and/or irregular pore or foramination patterns, which may include pores of any size, typically between about .01-3 mm, and more typically between about 0.1 mm to about 1 mm.

[0059] The term "macropores" refers to apertures having at least about a 0.5 mm diameter or width size, typically a diameter or width that is between about 1 mm to about 3 mm, and more typically a diameter or width that is between about 1 mm to about 1.5 mm (the width dimension referring to non-circular apertures). Where mesh keels are used, the macropores are larger than the openings or foramina of the mesh substrate. The macropores may promote bony through-growth for increased fixation and/or stabilization over time.

[0060] The term "loop" refers to a shape in the affected material that has a closed or nearly closed turn or figure. For example, the loop can have its uppermost portion merge into two contacting lower portions or into two proximately spaced

apart lower portions. The term "fold" means to bend over and the bend of the fold may have a sharp or rounded edge. The terms "pleat" or "fold" refer to doubling material on itself (with or without sharp edges).

[0061] **Figure 1** illustrates one embodiment of spinal disc implant **10**. The implant **10** can include at least one keel **15** on at least one primary surface. As shown, the implant **10** includes at least one flexible keel **15**. In this embodiment, the flexible keel **15** is an anterior/posterior keel. In the embodiment shown in **Figures 1** and **2**, the implant **10** includes both upper and lower keels **15u**, **15b** on respective superior and inferior primary surfaces. In the embodiment shown in **Figure 2**, the keel **15** can be oriented to run substantially laterally.

[0062] Other keel orientations and configurations may also be used. For example, **Figure 4A** illustrates that the upper keel **15u** can extend a first direction (such as anteriorly/posteriorly) and the bottom keel **15b** can extend in another direction (such as laterally). **Figure 4B** illustrates that one primary surface (shown as the inferior surface **12**) can have a lesser number of keels **15**. **Figure 9** illustrates that the keel **15** can be oblique or angled. The keel **15** can extend a distance outward from the implant body between about 2 to about 15 mm, typically between about 5 - 10 mm. The flexible keel **15** may provide twist or torsion resistance for the implant **10** and/or facilitate short and long term fixation.

[0063] **Figures 5A-5C** illustrate that the flex keel **15** can include structural reinforcement **15r**. The reinforcement **15r** can include, for example, coatings, materials or components that add rigidity to the keel **15**. The reinforcement can be applied to an outer portion and/or inner portion of the keel **15**. As shown in **Figure 5A**, an increased rigidity member **15m**, which can be a polymer or metallic mesh or solid member that resides in an interior portion of the keel **15**. **Figure 5B** illustrates that the reinforcement **15r** can include a discrete member **15m** that resides at an upper portion of the keel **15**. A pocket can be formed in the keel to maintain the desired location therein (top-to-bottom and/or end-to-end). Additional discrete or attached longitudinally spaced members can also be used (not shown). **Figure 5C** illustrates that the reinforcement **15r** can be a member **15m** that is molded into the implant body to extend into the keel interior.

[0064] As shown in **Figures 2** and **3**, the keel **15** is configured to enter a respective channel or mortise **25** formed in an adjacent vertebrae. The channel **25** can have a relatively shallow depth **25d** that is greater than the height of the keel **15**.

In some embodiments, the channel 25 can have a depth 25<sub>L</sub> that is between about 5-12 mm.

[0065] The implant 10 can include at least one flexible keel 15 extending from at least one surface. In some embodiments, the implant can include a plurality of keels from one or more surfaces (*see, e.g., Figure 4B*) and the implant 10 can include the same number of keels 15 extending from each primary surface or different numbers of keels 15 extending from each primary surface. The flexible keel(s) 15 can be porous, and in particular embodiments, can comprise a biocompatible elastomeric, typically polymer, mesh material. In the embodiments shown in **Figures 1 and 2**, the keel 15 is formed by a substantially outwardly extending (generally upwardly extending for the upper keel 15<sub>u</sub>) fold 15<sub>f</sub> formed in a unitary porous, typically mesh, material layer. One embodiment of the keel 15 is formed by a DACRON mesh of about 0.7 mm thick available as Fablok Mills Mesh #9464 from Fablok Mills, Inc., located in Murray Hill, NJ.

[0066] However, the flexible keel 15 can comprise other materials and can be formed or provided in other ways. For example, as shown in **Figure 6A**, the keel 15' can include two outwardly extending flexible members 18, 19 (which may be formed by two discrete end portions of mesh material bent upwardly or may be formed by a cut along the fold line). **Figure 6C** illustrates that a triple fold 15<sub>f</sub> can be used to form a keel 15'' and **Figure 6B** illustrates a double fold 15<sub>f</sub> can be used to form a keel 15'''.

[0067] Although shown in **Figures 1-3** as defined by a material layer on an outer surface of the implant body, the keel 15 can be defined by a material layer molded subsurface and/or embedded a distance into the implant body and anchored therein to extend a desired distance above or below the bounds of the implant body. The material layer(s) may be of a fabric single layer or laminated, including, for example, a DACRON mesh or felt or other biocompatible material.

[0068] In other embodiments, the implants 10 may be articulating implants with metallic or non-molded members. The flexible keel 15 can be ultrasonically welded, staked, brazed, adhesively attached, screwed, nailed or otherwise affixed, attached and/or mounted to a desired component to provide the flexible keel 15. In some-embodiments, the flexible keel 15 can be formed using non-elastomeric or non-polymer biocompatible materials including malleable metals,

metallic mesh and/or non-porous materials. For non-porous materials, the macropores can be arranged to provide sufficient fixation.

[0069] In some embodiments, the shape of the implant 10 can be described as a three-dimensional structure that provides anatomical shape, shock absorbency and mechanical support. The anatomical shape can have an irregular solid volume to fill the target intervertebral disc space. The coordinates of the body can be described using the anatomic directions of superior (towards the head), inferior (towards the feet), lateral (towards the side), medial (towards the midline), posterior (towards the back), and anterior (towards the front). From a superior view, the implanted device has a kidney shape with the hilum towards the posterior direction. The margins of the device in sagittal section are generally contained within the vertebral column dimensions. The term "primary surface" refers to one of the superior or inferior surfaces.

[0070] The size of the prosthetic spinal disc 10 can vary for different individuals. A typical size of an adult lumbar disc is 3-5 cm in the minor axis, 5 cm in the major axis, and 1.5 cm in thickness, but each of these dimensions can vary. It is contemplated that the implant 10 can be provided in a range of predetermined sizes to allow a clinician to choose an appropriate size for the patient. That is, the implant 10 can be provided in at least two different sizes with substantially the same shape. In some embodiments, the implant 10 can be provided in small, medium and large sizes. Further, the sizes can be configured according to the implant position – *i.e.*, and L3-L4 implant may have a different size from an L4-L5 implant. In some embodiments, an implant 10 can be customized (sized) for each respective patient.

[0071] The implant 10 can be configured as a flexible elastomeric MRI compatible (able to be placed in an MRI system and may be imageable) implant of a shape generally similar to that of a spinal intervertebral disc. The implant 10 can have a solid elastomeric body with mechanical compressive and/or tensile elasticity that is typically less than about 100 MPa (and typically greater than 1 MPa), with an ultimate strength in tension generally greater than about 100 kPa, that can exhibit the flexibility to allow at least 2 degrees of rotation between the top and bottom faces with torsions greater than about 0.01 N-m without failing. The implant 10 can be configured to withstand a compressive load greater than about 1 MPa.

[0072] The implant 10 can be made from any suitable elastomer capable of providing the desired shape, elasticity, biocompatibility, and strength parameters. The

implant 10 can be configured with a single, uniform average durometer material and/or may have non-linear elasticity (*i.e.*, it is not constant). The implant 10 may optionally be configured with a plurality of durometers, such as a dual durometer implant. The implant 10 can be configured to be stiffer in the middle, or stiffer on the outside perimeter. In some embodiments, the implant 10 can be configured to have a continuous stiffness change, instead of two distinct durometers. A lower durometer corresponds to a lower stiffness than the higher durometer area. For example, one region may have a compressive modulus that is between about 11-100 MPa while the other region may have a compressive modulus that is between 1-10 MPa.

[0073] The implant 10 can have a tangent modulus of elasticity that is between about 1-10 MPa (under normal spinal loads), typically about 3-5 MPa, and water content of between about 30-60%, typically about 50%.

[0074] Some embodiments of the implantable spinal disc 10 can comprise polyurethane, silicone, hydrogels, collagens, hyalurons, proteins and other synthetic polymers that are configured to have a desired range of elastomeric mechanical properties, such as a suitable compressive elastic stiffness and/or elastic modulus. Polymers such as silicone and polyurethane are generally known to have (compressive strength) elastic modulus values of less than 100 MPa. Hydrogels and collagens can also be made with compressive elasticity values less than 20 MPa and greater than 1.0 MPa. Silicone, polyurethane and some cryogels typically have ultimate tensile strength greater than 100 or 200 kiloPascals. Materials of this type can typically withstand torsions greater than 0.01 N-m without failing.

[0075] As shown in Figure 1, the spinal disc body 10 may have a circumferential surface 11, a superior surface 12, and an inferior surface 13. The superior and inferior surfaces 11, 12 may be substantially convex to mate with concave vertebral bones. The circumferential surface 11 of spinal disc body 10 corresponds to the annulus fibrosis ("annulus") of the natural disc and can be described as the annulus surface 11. The superior surface 12 and the inferior surface 13 of spinal disc body 10 correspond to vertebral end plates ("end plates") in the natural disc. The medial interior of spinal disc body 10 corresponds to the nucleus pulposus ("nucleus") of the natural disc.

[0076] The implant 10 may include a porous covering, typically a mesh material layer, 12c, 13c on each of the superior and inferior primary surfaces 12, 13, respectively. As shown, the implant 10 may also include a porous, typically mesh,

material layer **11c** on the annulus surface **11**. The annulus cover layer **11c** can be formed as a continuous or seamed ring to inhibit lateral expansion. In other embodiments, the annulus cover layer **11c** can be discontinuous. As also shown, the three coverings **11c**, **12c**, **13c** can meet at respective edges thereof to encase the implant body **10**. In other embodiments, the coverings **11c**, **12c**, **13c** may not meet or may cover only a portion of their respective surfaces **11**, **12**, and **13**.

[0077] **Figure 2** illustrates that the annulus cover **11c** and the superior cover **12c** can be oversized to extend beyond the bounds of the implant body and meet at a curvilinear upper anterior portion **20** of the implant **10**. Bone screws **50** or other attachment mechanisms can extend through these curvilinear segments **20** to help hold the implant in position in the patient's body. Similarly, the inferior cover **13c** can meet the annulus cover **11c** at a curvilinear lower anterior portion **21** of the implant. As shown in **Figure 3**, this configuration of the cover **11c** allows the use of four bone screws **50**. Additional attachment means, such as additional curved segments, or alternative attachment means can be employed such as integral tabs and the like, to allow for bone attachment configurations. Each curved segment or other configuration of tabs **21** can have a height between about a 2 mm -15 mm with a length (side-side width) being typically about 10 mm. The tabs **21** are located around the periphery of the implant (the tabs are disposed about the top and bottom). The tabs **21** can be provided by a single continuous skirt, or provided as discrete tab segments.

[0078] Alternatively, the annulus cover **11c** may terminate adjacent or inside the bounds of the annulus surface, or the superior or inferior covers **12c**, **13c** may terminate adjacent or within the bounds of the respective superior or inferior surfaces and not extend beyond the bounds of the implant. In such an embodiment, an outer portion of the superior or inferior covers **12c**, **13c** alone, or an upper or lower portion of the annulus cover **11c** alone, can be used to receive and attach the bone screw(s) and/or other attachment mechanisms **50**. The coverings may connect continuously or intermittently about respective perimeters, or may be spaced apart and not meet at all.

[0079] As shown in **Figures 1** and **2**, the implant **10** can be configured to be substantially encased in the same porous, typically mesh, material covering in the same thickness as that which forms the keel **15**. Alternatively, different material layers or different thickness of material layers can be used on different surfaces. For



example, the annulus material layer 11c may have additional thickness relative to the covering layer 12c, 13c on the superior or inferior surfaces 12, 13 of the implant.

[0080] Although shown as substantially conformally covering substantially the entire respective surfaces, the covers 11c, 12c, 13c may occupy a smaller portion of the respective surface 11, 12, 13, such as a minor portion (not shown). The coverings 11c, 12c, 13c can be configured to allow substantially vertical passive expansion or growth of between about 1-40%, typically, about 20-30%, *in situ* as the implant 10 absorbs or intakes liquid due to the presence of body fluids. The passive growth can be measured outside the body by placing an implant in saline at room temperature and pressure for 5-7 days, while held in a simulated spinal column in an invertebrate space between two simulated vertebrae. It is noted that the passive expansion can vary depending, for example, on the type of covering or mesh employed and the implant material. For example, in some embodiments, the mesh coverings 11c, 12c, 13c along with a weight percentage of (PVA) used to form the implant body are configured to have between about 1-5% expansion *in situ*.

[0081] In the embodiment shown in Figures 1-3, the keel 15 has a fold or loop 15f formed such that the tip of the fold 15t is closed and the two legs 15<sub>1</sub>, 15<sub>2</sub> are spaced apart to define an elongate gap space 15g (Figure 2) therebetween. Figure 8 illustrates that the spacing can be such that the keel 15 has a tent-like cross-sectional or end view shape with a top angled (rather than rounded) corner. Figure 1 illustrates that the spacing can be such that the keel legs 15<sub>1</sub>, 15<sub>2</sub> are in contact via their inner surfaces over a major portion of its length.

[0082] In end view, such as shown in Figure 3, the keel 15 can include a closed tip or crown 15t and closely spaced legs of the folds 15<sub>1</sub>, 15<sub>2</sub>. The legs 15<sub>1</sub>, 15<sub>2</sub> can merge into the conformal covering material 12c, 13c. The legs 15<sub>1</sub>, 15<sub>2</sub> can contact as they approach the implant body 10 or can be spaced apart a distance such as about 0.01 mm to about 10 mm, typically between about 0.1 mm to about 1 mm.

[0083] In some embodiments, the legs 15<sub>1</sub>, 15<sub>2</sub> may be attached (continuously or discontinuously) along a lengthwise direction at one or more of an upper, medial or lower portion, or may have other structural reinforcement means (not shown). Portions of the keel 15 can be attached via any suitable biocompatible attachment means, such as heat-sealed, ultrasonically attached, molded, adhesively bonded or stitched together. Alternatively, or additionally, the legs of the fold 15<sub>1</sub>,

**15<sub>2</sub>** may have horizontal, vertical or angled stiffeners or other reinforcement means. In addition, in some embodiments, the keel **15** may comprise a biocompatible coating or additional material on an outer and/or inner surface (or in the gap space) that can increase the stiffness of the keel **15**. *See also, Figures 5A-5C.* The stiffening coating or material can include PVA cryogel. The annulus cover **11C** (also described as a "skirt") may also include stiffening or reinforcement means such as those described herein for the keel **15**.

[0084] As shown in **Figure 7**, the keel **15** can include a plurality of spaced apart apertures **40**. The apertures **40** can be macropores formed through the wall(s) of the keel **15** that can facilitate bone or tissue in-growth. The apertures **40** can be aligned or misaligned over at least a major portion of a length of the keel **15**.

[0085] **Figure 10A** illustrates that one or more keels **15** can occupy or span a subportion (less than the entire distance) of the respective primary surface. As shown in **Figure 10**, the superior surface **12** can include two spaced apart axially aligned keels **15a**. The keels **15a** can have the configurations discussed elsewhere. In the embodiment shown, the keels **15a** have different shapes as they extend from the same surface and can have different configurations as they extend from different primary surfaces (*i.e.*, the respective inferior and superior surfaces). **Figure 10B** illustrates that the keels **15a** can include apertures **40**.

[0086] **Figures 11A** and **11B** illustrate that the keel **15** can be configured with subsurface attachment segments **15s**. As shown in **Figure 11A**, the implant **10** has a primary body **10b** (typically a molded elastomeric body) and the keel **15** has subsurface attachment segments **15s** that extend a minor distance into the implant body **10b** (such as, for example, between about 5-30% of the cross-sectional distance). As shown in **Figure 11A**, an outer liner layer **12c** may reside on the outside of the implant body **10b** with the subsurface attachment segments **15s** disposed thereunder. The segments **15s** can be integrally attached to the liner layer **11c** prior to securing to the primary implant body **10b** or may be attached during the fabrication process. **Figure 11B** illustrates that the flexible keel **15** can be defined by anchoring a layer thereof into the implant body **10b**. An optional outer liner **12c** may be placed about the keel **15**. Different materials can be used to form the keel **15** and subsurface segments **15s** and the liner **11c**, where used. Also, although shown as extending from one primary surface for discussion, the implant **10** can be configured

with one or more keels **15** that extend from the other or both surfaces (and this is applicable to other embodiments shown or discussed herein).

[0087] Some embodiments of the spinal disc implant **10** are configured so that they can mechanically function as a substantially normal (natural) spinal disc and can attach to endplates of the adjacent vertebral bodies. The implant **10** can expand *in situ* to restore the normal height of the intervertebral space. The implant **10** can be configured to expand, for example, between about 1-40%, typically about 20%, after implantation relative to its configuration at the time of implantation. It is envisioned that the spinal disc implant **10** can be inserted by a surgical procedure into the target intervertebral space. It may be used for separation of two bony surfaces within the spine. In other embodiments, the implant may be configured for use with respect to other bones of the body.

[0088] As shown, for example, in **Figures 4 and 5**, the spinal disc implant **10** can be substantially rectangular when viewed from at least one side. As shown in **Figures 1 and 2**, the superior surface **12** and the interior surface **13** can be shaped to be substantially convex in order to provide a good interface with the superior and inferior vertebral bodies, **16** and **17** (**Figures 2 and 3**), respectively.

[0089] As shown in **Figure 1**, the spinal disc body **10** is generally of kidney shape when observed from the superior, or top, view, having an extended oval surface and an indented portion. As shown in **Figure 2**, the anterior portion **10a** of spinal disc **10** can have greater height than the posterior portion **10p** of spinal disc **10** in the sagittal plane. The implant **10** can be configured with a mechanical compressive modulus of elasticity of about 1.0 MPa, ultimate stretch of greater than 15%, and ultimate strength of about 5 MPa. The device can support over 1200 N of force. Further description of an exemplary flexible implant is described in co-pending U.S. Patent Application Publication No. 20050055099, the contents of which are hereby incorporated by reference as if recited in full herein.

[0090] Elastomers useful in the practice of the invention include silicone rubber, polyurethane, polyvinyl alcohol (PVA) hydrogels, polyvinyl pyrrolidone, poly HEMA, HYPAN<sup>TM</sup> and Salubria<sup>®</sup> biomaterial. Methods for preparation of these polymers and copolymers are well known to those of skill in the art. Examples of known processes for fabricating elastomeric cryogel material is described in Patent Nos. 5,981,826 and 6,231,605, the contents of which are hereby incorporated by reference. *See also*, Peppas, Poly (vinyl alcohol) hydrogels prepared by

freezing--thawing cyclic processing; and Polymer, v. 33, pp. 3932-3936 (1992); Shauna R. Stauffer and Nikolaos A. Peppas.

[0091] **Figure 12** is a flow chart of exemplary operations that can be carried out to form an implant with at least one flexible keel according to embodiments of the present invention. Although described herein as particularly suitable for spinal disc implants, it is contemplated that the methods of fabricating implants and/or keels can be used for other implants as well. An elastomeric primary body of an implant can be molded into a desired implant shape (block 175). At least one flexible keel can be attached to the molded implant so that the at least one flexible keel extends outwardly from at least one of a superior or inferior surface of the molded implant (block 180).

[0092] In some embodiments, the implant is a solid PVA hydrogel having a unitary body shaped to correspond to a natural spinal disc (block 177). An exemplary hydrogel suitable for forming a spinal implant is (highly) hydrolyzed crystalline poly (vinyl alcohol) (PVA). PVA cryogels may be prepared from commercially available PVA material, typically comprising powder, crystals or pellets, by any suitable methods known to those of skill in the art. Other materials may also be used, depending, for example, on the application and desired functionality. Additional reinforcing materials or coverings, radiopaque markers, calcium sulfates or other materials or components can be molded on and/or into the molded body. Alternatively, the implant can consist essentially of only the molded PVA body.

[0093] In some embodiments, the flex keel can be attached by molding a mesh cover layer with at least one upwardly or downwardly extending fold onto at least one of the primary surfaces (block 181). Optionally, two mesh layers can be attached to the implant body, one to each respective superior and inferior surface and a third mesh layer can be attached to the annulus surface to substantially encase the implant body (block 182).

[0094] Referring to **Figure 13A**, in some embodiments, a moldable material is placed in a mold 200. The moldable material comprises an irrigant and/or solvent 250 and about 25 to 60% (by weight) PVA powder crystals 240. The PVA powder crystals can have a MW of between about 124,000 to about 165,000, with about a 99.3-100% hydrolysis. The irrigant or solvent 250 can be a solution of about 0.9% sodium chloride. The PVA crystals 240 can be placed in the mold 200 before

the irrigant (no pre-mixing is required). The mold **200** has the desired 3-D implant body shape. As shown, the mold **200** includes a floor **201** with a channel or aperture **202** that is sized and configured to receive the keel **15** of a respective cover layer **13c** (shown as layer **13c**, but the floor **201** could receive layer **12c**, depending on the mold orientation).

[0095] As shown in **Figure 13B**, a lid **205** can be used to close the mold **200**. The closed mold **200** can be evacuated or otherwise processed to remove air bubbles from the interior cavity. For example, the irrigant can be overfilled such that when the lid is placed on (clamped or secured to) the mold **200**, the excess liquid is forced out thereby removing air bubbles. In other embodiments, a vacuum can be in fluid communication with the mold cavity to lower the pressure in the chamber and remove the air bubbles. The PVA crystals and irrigant can be mixed once in the mold, before and/or after the lid is closed. Alternatively, the mixing can occur naturally without active mechanical action during the heating process.

[0096] As also shown in **Figure 13B**, the keel **15** can reside in the floor channel or aperture **202** below the floor **201**. The lid **205** can be similarly configured where keels are desired on both primary surfaces. The irrigant **250** and PVA crystals **240** in the mold **200** are heated. Typically, the mold with the moldable material is heated to a temperature of between about 80°C to about 200°C for a time sufficient to form a solid molded body. The temperature of the mold can be measured on an external surface. The mold can be heated to at least about 80-200°C for at least about 5 minutes and less than about 8 hours, typically between about 10 minutes to about 4 hours, the (average or max and min) temperature can be measured in several external mold locations. The mold can also be placed in an oven and held in the oven for a desired time at a temperature sufficient to bring the mold and the moldable material to suitable temperatures. In some embodiments, the mold(s) can be held in an oven at between about 50-200 °C, typically between about 100-200°C for about 2-6 hours, the higher range may be used when several molds are placed therein, but different times and temperatures may be used depending on the heat source, such as the oven, the oven temperature, the configuration of the mold, and the number of items being heated.

[0097] **Figure 14** illustrates that three covering layers **11c**, **12c**, **13c** can be placed in the mold as pre-cut or shaped releasable liners before the PVA crystals and irrigant. The liners **11c**, **12c**, **13c** integrally attach to the molded implant body during

the molding process. In some embodiments, osteoconductive material, such as, for example, calcium salt can be placed on the inner or outer surfaces of the covering layers **11c**, **12c**, **13c**, and/or the inner mold surfaces (wall, ceiling, floor) to coat and/or impregnate the mesh material to provide osteoconductive, tissue-growth promoting coatings.

**[0098]** The mold **200**, **201** and liners **11c**, **12c**, **13c** can be configured to provide the bone attachment extension segments **20**, **21**, discussed above.

**[0099]** After heating, the implant body can be cooled passively or actively and/or frozen and thawed a plurality of times until a solid crystalline implant is formed with the desired mechanical properties. The molded implant body can be removed from the mold prior to the freezing and thawing or the freezing and thawing can be carried out with the implant in the mold. Alternatively, some of the freeze and thaw steps (such as, but not limited to, between about 0-10 cycles) can be carried out while the implant is in the mold, then others (such as, but not limited to, between about 5-20 cycles) can be carried out with the implant out of the mold.

**[0100]** Before, during and/or after freezing and thawing (but typically after demolding), the molded implant **10** can be placed in water or saline (or both or, in some embodiments, neither). The device **10** can be partially or completely dehydrated for implantation. The resulting prosthesis can have an elastic modulus of at least about 2 MPa and a mechanical ultimate strength in tension and compression of at least 1 MPa, preferably about 10 MPa, and under about 100 MPa. The prosthesis may allow for between about 1-10 degrees of rotation between the top and bottom faces with torsions of at least about 1 N-m without failing. The implant can be a single solid elastomeric material that is biocompatible by cytotoxicity and sensitivity testing specified by ISO (ISO 10993-5 1999: Biological evaluation of medical devices - Part 5: Tests for *in vitro* cytotoxicity and ISO 10993-10 2002: Biological Evaluation of medical devices-Part 10: Tests for irritation and delayed-type hypersensitivity.).

**[0101]** The testing parameters used to evaluate the compressive tangential modulus of a material specimen can include:

Test type: unconfined compression  
Fixtures: flat platens, at least 30 mm diameter  
Rate: 25.4 mm/sec to 40% strain  
Temperature: room temp (~22°C)

Bath: samples stored in saline or water until immediately before test  
Samples: cylinders,  $9.8 \pm 0.1$  mm height,  $9.05 \pm 0.03$  mm diameter

Compressive Tangential Modulus calculated at 15, 20, and 35% strain

[0102] Figure 15 is a schematic illustration of an exemplary production system 500 that can be used to fabricate spinal implants according to embodiments of the present invention. As shown, a series of mold shells 225 holding a plurality of molds 200 can be serially advanced along a process line. The mold shells 225 can be advanced via a belt drive or conveyor system 510. At a first station A (515), the desired liner 11c, 13c can be placed in the molds 200. Where flexible keels 15 are formed on the implant using the liner material (12c or 13c), the mold floor 201 can include a receiving channel or aperture 202 (Figures 16A-16C).

[0103] At a next station B (518), the mold material 245 can be added to the molds 200. As shown, the mold material includes PVA 240 that is added first, then liquid 250 that is added next. However, it is noted that, in other embodiments, the mold material can be added as a flowable liquid (the PVA and liquid or other elastomeric constituents can be pre-mixed and may be pre-heated to form a viscous flowable slurry or mixture). The mold shells 225 can optionally vibrate or oscillate to mix the mold material as the mold shells move along the process flow path.

[0104] At station C (520), a top layer 12c can be placed on the material in the mold 200. A lid 205 can be used to close the mold 200. In embodiments wherein a flexible keel 15 is formed using the top layer 12c, a ceiling in the lid 205c can include a keel receiving aperture or channel 206, similar to the floor aperture or channel 202 discussed herein. The closed mold can be advanced to station D (522) where the molds 200 are exposed to a heat source 299 and heated to a desired time and temperature sufficient to impart the desired heat for a desired time to the moldable material held in the molds 200. The heat source 299 can be a stationary oven and the molds 200 can be placed on columns of racks therein. Alternatively, the drive system can be configured to automatically advance the molds therein and hold the molds in the oven for the desired time. Temperature sensors can be placed on and/or in the mold to confirm desired threshold temperatures are achieved for a desired time.

[0105] The implants 10 can be processed in several freeze-thaw cycles as discussed above. The implants 10 can be sterilized with sterile heated liquid or with

radiation or other sterilization methods, typically after packaging in medical pouch or other suitable container to provide a sterile medical product.

[0106] **Figure 16A** illustrates a mold **200** with a mold bottom **200b** that holds the mold floor **201**. As shown, the cover **13c** includes the keel **15** that resides in the channel **202ch** (**Figure 16B**) or aperture **202a** (**Figure 16C**) in the floor **201**. As also shown, the cover **11c** is placed in the mold **200** adjacent the sidewall(s) **203** of the mold. In other embodiments, the keel **15** may be folded under the bottom of the covering **13c** during the molding process and the floor can be configured to accommodate this region of extra thickness. The ceiling of the mold can be similarly configured.

[0107] **Figure 17A** illustrates a multi-piece mold **200** that can be used to form implants according to embodiments of the present invention. As shown, the mold **200** includes a middle body **208**, a bottom member **201** with the floor **202**, a top member **205** with a ceiling **206**, and a lower plate **209**. The top member **205** and bottom member **201** are configured to enter opposing end portions of the middle body **208**. Alignment pins **211** or other devices can be received in matable apertures **211m** to help guide and/or secure the components together. The top member **205** may include a liquid and/or air vent **216**. The vent **216** can allow excess irrigant (such as saline) to be expelled from the mold cavity when the lid is attached thereto. The vent **216** can be used for degassing of the mold cavity (vacuumed) before the heating step. That is, the substantially closed mold can be placed in a vacuum chamber (typically at 20-30 in Hg (inches of Mercury)) for a short time, such as less than five minutes. Then the vent **216** can be closed to seal the mold before putting the sealed mold in the oven or exposing to heat using another heat source.

[0108] As shown in **Figure 17B**, when attached, the top member **205**, bottom member **201** and middle body **208** define the shape of the implant **10**. The bottom member has an interior cavity that defines the floor **202** that forms the shape of the anterior portion of the implant (and, as appropriate, the aperture or channel for the keel). Similarly, the top member **205** forms the ceiling that defines the shape of the top (superior surface) of the implant. The middle body **208** defines the shape of the longitudinal (annular) perimeter of the implant. As shown, the top member **205** can include a lateral flange **205f** that can be clamped or otherwise secured to the plate **209** to hold the mold **200** tightly together. In some embodiments, as shown, resilient members such as springs **215** (leaf springs or disc springs) can be inserted underneath



one or more screw heads 217 used to attach the lid 205 to the mold body. The springs 215 may also be inserted at the floor end 209 (not shown). The springs 215 can allow limited or controlled expansion of the mold cavity while keeping the mold closed (retaining the cavity under pressure) to compensate for volume changes as the mold and the molded material therein cool down (the thermal coefficient of the mold and the molded material is typically different). Other thermal compensation mechanisms and configurations may also be used.

[0109] Figure 18 is an end view of the middle body 208 illustrating an exemplary interior shape 208i that may be particularly suitable for a TDR spinal implant. As shown, the sidewall of the middle body 208 defines a perimeter wall shape of the implant 10. The middle body 208 can include circumferentially spaced apart apertures 208a that can align with apertures in the other matable mold components. It is noted that although the exterior of the mold 200 is shown as substantially tubular, other shapes may also be used. Figure 19 illustrates an end view of the bottom plate 209 that can securely attach to middle body 208. The plate 209 includes apertures 209a as well as the guide pin 211 that is received into the bottom member 200b (Figure 17A).

[0110] Figures 20A and 20B illustrate an exemplary top mold member 205. The top mold member 205 can include apertures 205a. As shown, the top member 205 and plate 209 can include the same number of apertures while the middle body 208 may include a lesser number. The extra holes/apertures can be used for demolding purposes (e.g., shedding or separating the mold from the molded implant). The top mold member 205 can have a lower portion that enters the middle body 208 with substantially the same perimeter shape 206p as the middle body perimeter shape 208p. The lowermost portion 205l of the top member 205 is shaped to define a desired moldable (superior) shape in the implant 10. As noted above, the vent 216 can be used for one or more of insertion of saline, venting of excess saline and/or degassing of the mold cavity (during evacuation with the mold in a vacuum chamber) before the heating cycle. In operation, after the lid is placed on the mold cavity, saline can be placed in the reservoir 222. The mold 200 can be placed in a vacuum chamber for a desired time. The saline is drawn into the mold cavity and air is removed via vent 216. Typically, a small amount of saline, such as less than about 10% of the volume of the reservoir, resides in the reservoir 222 after the evacuation process. The mold 200 can be sealed by attaching a closure member, such as a screw

or plug in the vent port **216p**, shown disposed at the bottom of the reservoir **222**. The sealed mold is then placed in a heater/oven.

[0111] Figures **21A** and **21B** illustrate an exemplary bottom mold member **200b**. As shown, the outer perimeter shape **201p** is substantially the same as the perimeter shape **208p** of the middle member **208**. The bottom member **200b** defines the floor **201** shape and includes a channel **202**.

[0112] Figure **22** illustrates an exemplary fabrication process similar to that described with respect to Figure **13** above that can be used to form any suitable implant and is not limited to spinal implants. Because the implants can be manufactured to be mechanically strong, or to possess various levels of strength among other physical properties, the process can be adapted for use in many applications. The cryogel also has a high water content, which provides desirable properties in numerous applications. For example, the cryogel tissue replacement construct is especially useful in surgical and other medical applications as an artificial material for replacing and reconstructing soft tissues or as orthopedic implants in humans and other mammals.

[0113] The fabrication process can include introducing a quantity of PVA crystals into a mold cavity (block **400**). A quantity of liquid, typically an aqueous solution or water, can be added to the PVA crystals to form a PVA mixture (block **405**). The liquid may optionally comprise saline (block **406**). A mold lid is attached to substantially close the mold cavity (block **408**). The liquid and/or the crystal or powder PVA material can be added independently after the lid is attached using a vent with a vent path in fluid communication with the mold cavity (block **407**). The vent can be used to degas air from the mold cavity before heating, typically during evacuation of the mold cavity. The vent can be sealed before the heating step. Typically, the PVA is added before the lid is attached as well as any liner material desired (block **409**) and the liquid introduced after the lid is attached. Alternatively, both the PVA and liquid can be introduced (all or portions of same) before the lid is attached. The mold cavity may become pressurized from heating the mixture in the sealed mold (a relatively high pressure is contemplated, but has not been measured). The mold with the PVA mixture can be heated to a desired temperature for a desired time to form the PVA mixture into a molded body with a desired shape (block **410**). The mold with the molded body therein can be cooled after the heating (block **412**). The cooling can be passive (air cooled at room temperature) or active such as forced

air flow, fluid flow, refrigeration, and may include regulated temperatures or not, or the cooling can include both passive and active types of cooling.

[0114] In some embodiments, the mold cavity can be allowed to change in volume, (typically shrink) while inhibiting the introduction of air in the mold cavity while cooling the mold and the molded PVA body (which can be held sealed therein) during a cooling cycle (block 415). The PVA molded body can be freeze-thaw cycled (in and/or out of the mold) at least one, and typically a plurality of times (block 416). As discussed above, the moldable material can include between about 20 to about 70% (by weight) PVA powder crystals. The PVA powder crystals can have a MW of between about 124,000 to about 165,000, with about a 99.3-100% hydrolysis. The saline (irrigant, solution, and/or solvent) can be a solution of about 0.9% sodium chloride. The PVA crystals can be placed (dry) in the mold independently of, typically before, the irrigant (no pre-mixing is required) and/or otherwise introduced into the mold so that injection is not required. The irrigant and PVA, or just the irrigant, can be inserted into a mold after a lid is attached using a liquid vent port that can be plugged or sealed before the material and the mold are heated. After cooling, the hydrogel-molded body can be further processed without placing in water or saline during subsequent processing. The hydrogel body can be hydrated at least partially (and may, in some embodiments be substantially completely hydrated) before packaging in a medical kit and ready for insertion and/or before implantation. Other characteristics, features, materials or process steps for the implant fabrication can be used as described hereinabove with respect to other figures.

[0115] Soft tissue body parts, which can be replaced or reconstructed by the cryogel include, but are not limited to, vascular grafts, heart valves, esophageal tissue, skin, corneal tissue, cartilage, meniscus, and tendon. Furthermore, the cryogel may also serve as a cartilage replacement for anatomical structures including, but not limited to an ear or nose. Orthopedic implants include, but are not limited to knee, arm and hip joint replacements, load bearing surface implants and prosthetic limbs.

[0116] The cryogel may also serve as a tissue expander. Additionally, the inventive cryogel may be suitable for an implantable drug delivery device. In that application, the rate of drug delivery to tissue will depend upon cryogel pore size and degree of intermolecular meshing resulting from the freeze/thaw device. The rate of drug delivery increases with the number of pores and decreases with an increasing degree of intermolecular meshing from an increased number of freeze/thaw cycles.

The cryogel may also be suitable for vascular grafts and heart valve replacements, because the cryogel is thromboresistant, and because of the particular mechanical and physiological requirements of vascular grafts when implanted into the body. The cryogel may also be used for contact lenses, as a covering for wounds such as burns and abrasions, and in other applications wherein a mechanically strong material is desired.

[0117] The foregoing is illustrative of the present invention and is not to be construed as limiting thereof. Although a few exemplary embodiments of this invention have been described, those skilled in the art will readily appreciate that many modifications are possible in the exemplary embodiments without materially departing from the novel teachings and advantages of this invention. Accordingly, all such modifications are intended to be included within the scope of this invention as defined in the claims. The invention is defined by the following claims, with equivalents of the claims to be included therein.

## THAT WHICH IS CLAIMED:

1. A medical device fabrication mold, comprising:
  - a mold having a three-dimensional mold cavity with a target shape, the mold cavity having an upstanding sidewall and a releasably attachable floor and ceiling;
  - at least one mesh layer disposed in the mold cavity; and
  - a quantity of polyvinyl alcohol (PVA) material and irrigation fluid disposed in the mold cavity over the at least one mesh layer to form a hydrogel body, such that, during exposure to heat, the PVA permeates the at least one mesh layer to integrally attach the mesh layer to the hydrogel implant body to define a molded medical device.
  
2. A mold according to Claim 1, wherein the at least one mesh layer comprises three mesh liner layers in the mold cavity, one configured to at least partially cover the floor, one configured to at least partially cover the upstanding sidewall, and one configured to at least partially reside under the ceiling over the quantity of polyvinyl alcohol material and irrigation fluid in the mold cavity.
  
3. A mold according to Claim 1, wherein the mold cavity three-dimensional shape substantially corresponds to a shape of a natural spinal disc, and wherein the mold is configured to produce an implantable TDR spinal disc prosthesis.
  
4. A mold according to Claim 1, wherein the releasably attachable ceiling comprises a reservoir and vent path, the vent path in fluid communication with the mold cavity, and the mold further comprises a releasable vent plug sealably attached to the vent path.
  
5. A medical implant mold comprising:
  - a mold body having a three dimensional shape and a mold cavity;
  - a releaseable lid attached to the mold body, the lid comprising a liquid reservoir;
  - a vent path extending through the lid in fluid communication with the mold cavity and the liquid reservoir; and
  - a releasably attachable vent plug sealably attached to the vent path.

6. An implant according to Claim 5, further comprising a plurality of elongate mold attachment members with heads, the elongate members extending through the lid to releasably sealably attach the lid to the mold body; and

a plurality of springs, one residing between a respective elongate member head and lid to thereby allow for variation in volume in the cavity during thermal processing while keeping the mold body and lid attached.

7. A medical implant mold according to Claim 5, further comprising PVA material held in the sealed mold.

8. A medical implant mold according to Claim 7, wherein the mold defines a total disc replacement implant.

9. A medical implant mold according to Claim 7, further comprising at least one of calcium sulfate, mesh material and reinforcing material disposed in the mold.

10. A medical implant mold according to Claim 8, further comprising at least one radiopaque marker disposed in the sealed mold.

11. A method of fabricating an implantable prosthesis, comprising:  
placing an inferior mesh layer on a floor of a three-dimensional mold;  
introducing moldable material into the mold onto the inferior mesh layer;  
placing a superior mesh layer on a top surface of the moldable material in the mold; then

closing the mold;

pushing any excess moldable material out of the mold in response to the closing step; and

heating the mold with the moldable material to a desired temperature so that the mold is heated to at least about 80°C for at least about 5 minutes; then

forming a molded implant body formed by the heated moldable material whereby the mesh layers are integrally attached to the molded body formed by the moldable material.

12. A method according to Claim 11, further comprising placing an annular mesh layer against an upstanding sidewall of the mold before the introducing step.

13. A method according to Claim 11, wherein the moldable material includes PVA crystals, granules or powder and a liquid irrigation solution that defines a PVA hydrogel, wherein the heating is carried out to heat the mold with the moldable material to between about 80-200°C for at least about 5 minutes to less than about 8 hours, the method further comprising:

freezing and thawing the PVA hydrogel molded body a plurality of times after the heating to provide a flexible crystalline implant body with a desired compressive modulus of elasticity.

14. A method of fabricating a medical implant, comprising:  
introducing a quantity of PVA material into a mold cavity of a mold;  
inserting a quantity of saline into the mold cavity independently of the introduction of the PVA material;

placing a lid on the mold to close the mold cavity with the PVA material and saline;

heating the mold for a desired time and temperature so that the PVA material and saline reach a desired temperature and form a molded body;

cooling the mold with the molded body after the heating step; and  
forming a medical PVA hydrogel implant.

15. A method according to Claim 14, further comprising inserting radiopaque marker into the mold before the placing step.

16. A method according to Claim 14, further comprising inserting calcium sulfate in the mold before the placing step.

17. A method according to Claim 14, further comprising inserting reinforcing material in the mold before the placing step.

18. A method according to Claim 14, further comprising allowing the mold cavity to vary in volume while inhibiting the introduction of air into the mold cavity during at least a portion of the cooling step.

19. A method according to Claim 14, wherein the mold has a vent path that extends through the mold lid, the method further comprising:

evacuating the closed mold in a vacuum chamber with the vent path open; and  
sealing the vent path before the heating step.

20. A method according to Claim 19, wherein the lid comprises a reservoir, the method further comprising placing saline in the reservoir with the vent path open before the evacuating step, then inserting a vent closure member through liquid in the reservoir to seal the mold before the heating step.

21. A medical implant formed by the method of Claim 14.

22. A medical implant according to Claim 21, wherein the implant consists essentially of molded polyvinylalcohol (PVA) cryogel with an integral external covering fused to the implant by the PVA.

23. A method of fabricating a medical implant, comprising:  
placing a lid on a mold to substantially close a mold cavity;  
introducing a quantity of PVA material into the mold cavity before or after the placing step;

inserting a quantity of liquid through a vent path extending through the mold lid after the lid is placed on the mold whereby the liquid enters the mold and contacts the PVA material; then

sealing the vent path; then

heating the mold for a desired time and temperature so that the PVA and liquid reach a desired temperature and form a molded body;

cooling the mold with the molded body after the heating step; and

forming a medical PVA hydrogel implant.



24. A method according to Claim 23, further comprising maintaining the sealed condition of the mold during the heating and at least a portion of the cooling step.

25. A method according to Claim 23, the method further comprising:  
evacuating the closed mold in a vacuum chamber with the vent path open before the sealing step; and  
sealing the vent path before the heating step.

26. A method according to Claim 25, wherein the lid comprises a liquid reservoir, the method further comprising placing liquid in the reservoir with the vent path open before the evacuating step.

27. A method according to Claim 26, the method further comprising inserting a vent closure member through liquid in the reservoir to seal the mold before the heating step.

28. A method according to Claim 26, wherein the liquid is saline.

29. A medical implant formed by the method of Claim 23.

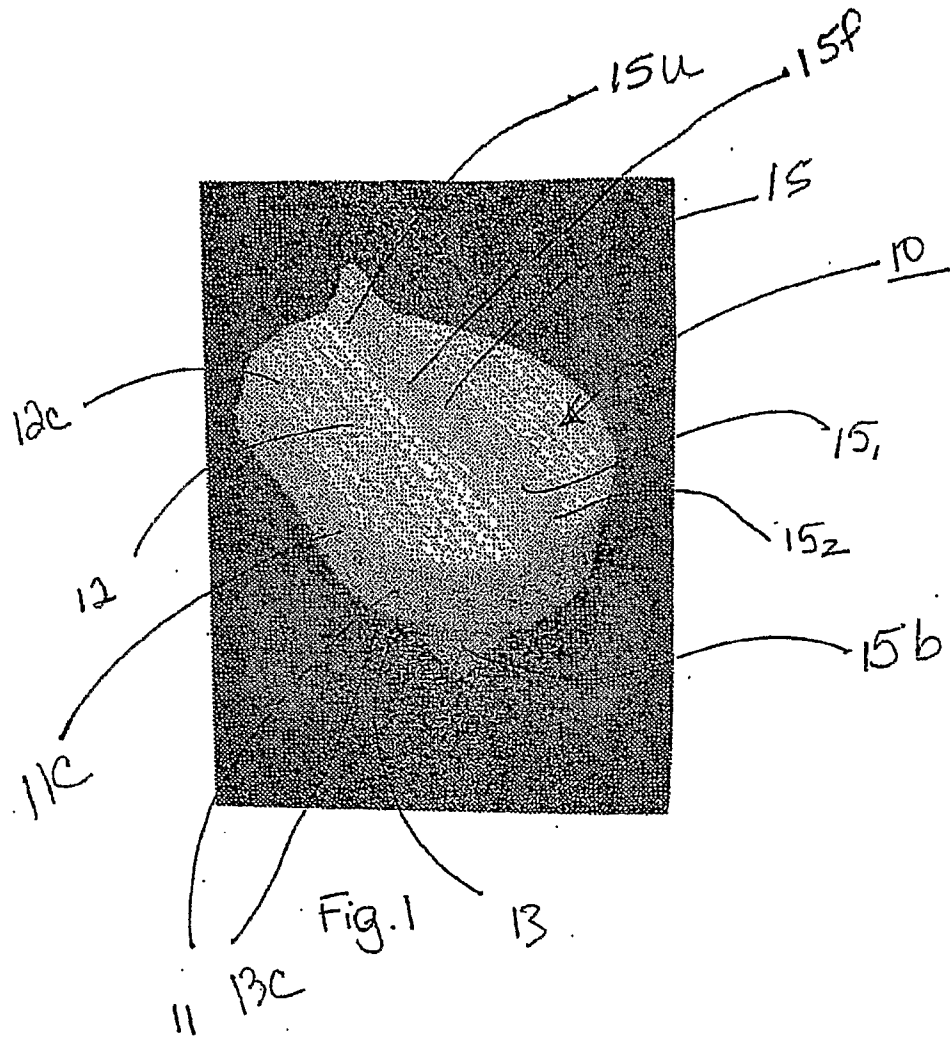

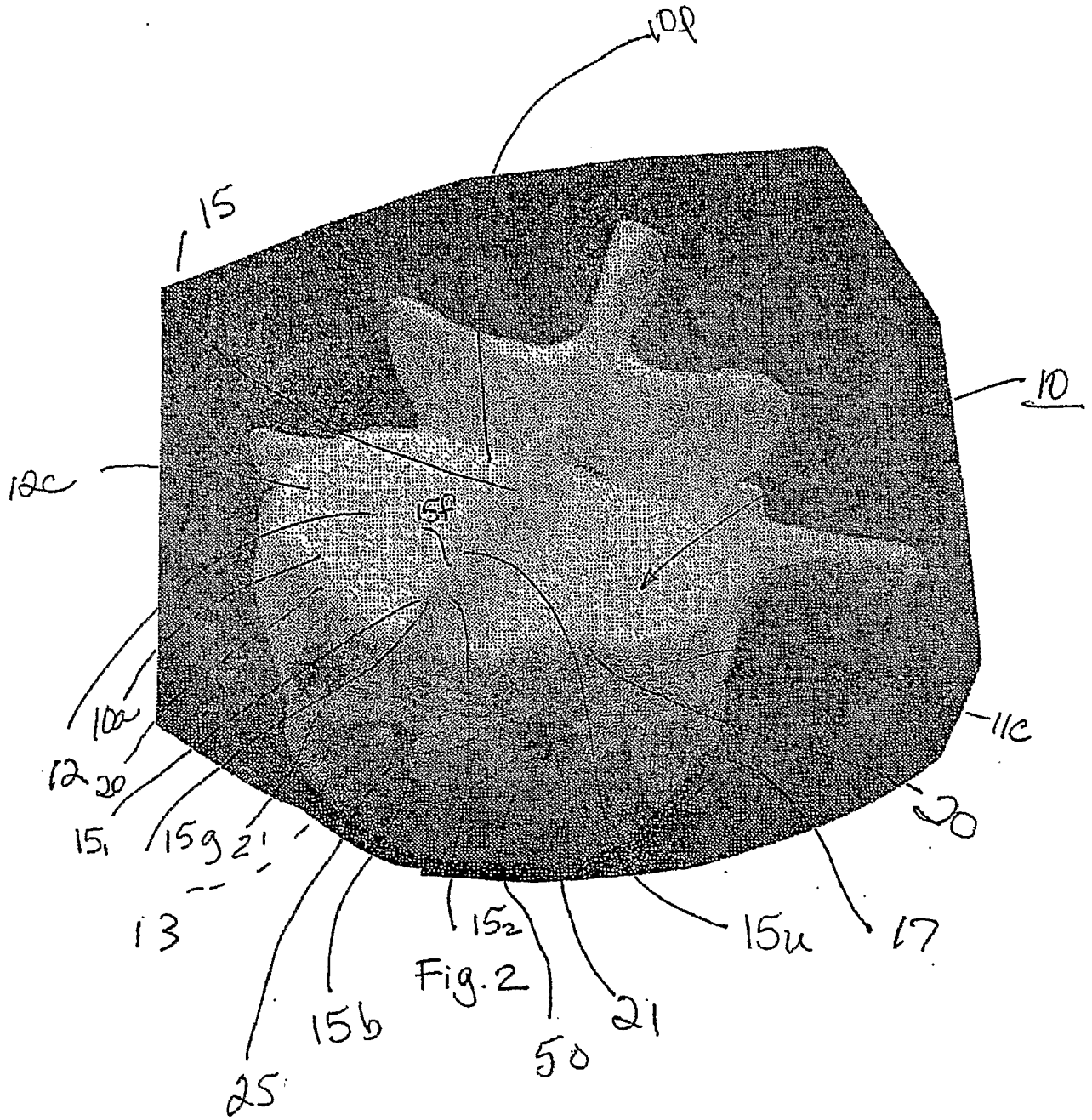

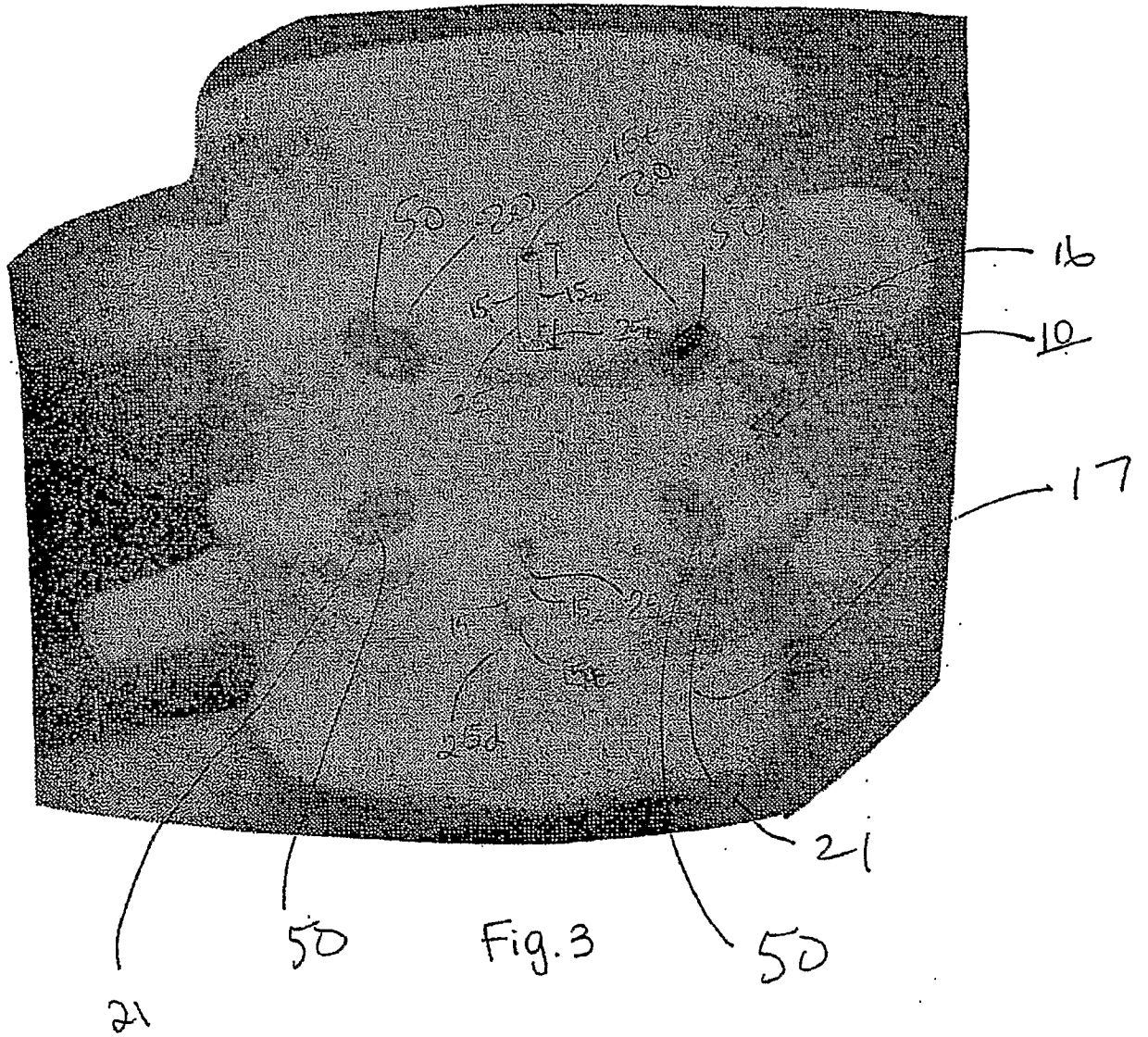

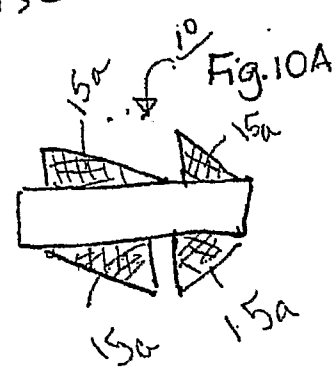
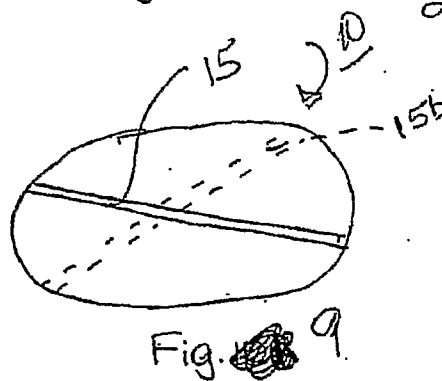
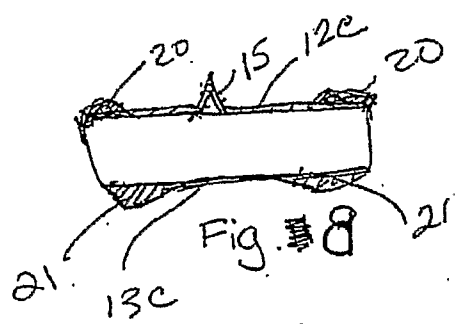
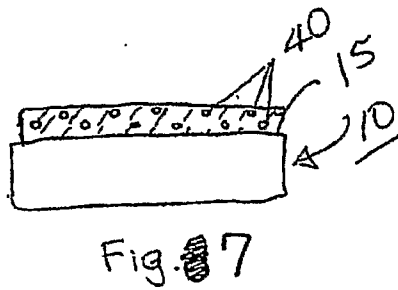
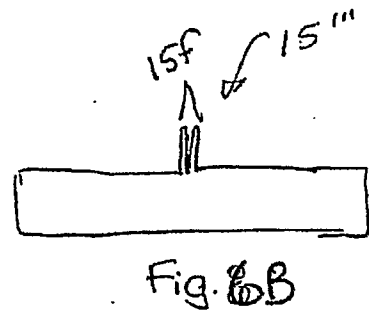
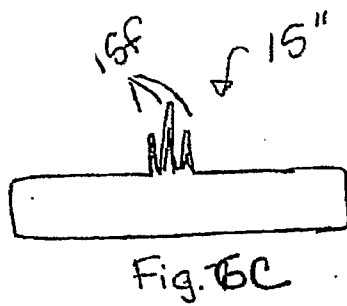
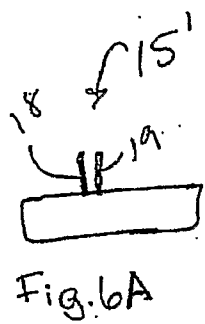
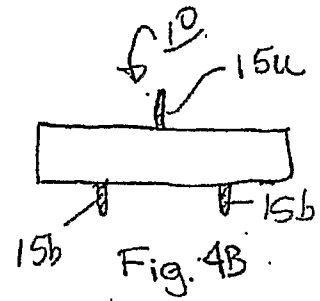
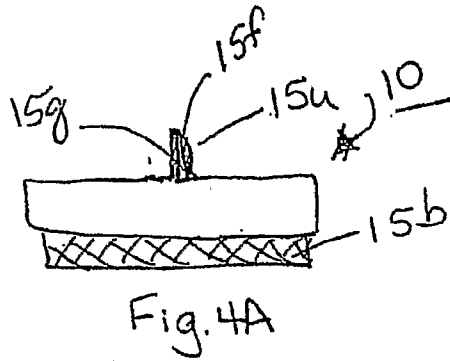
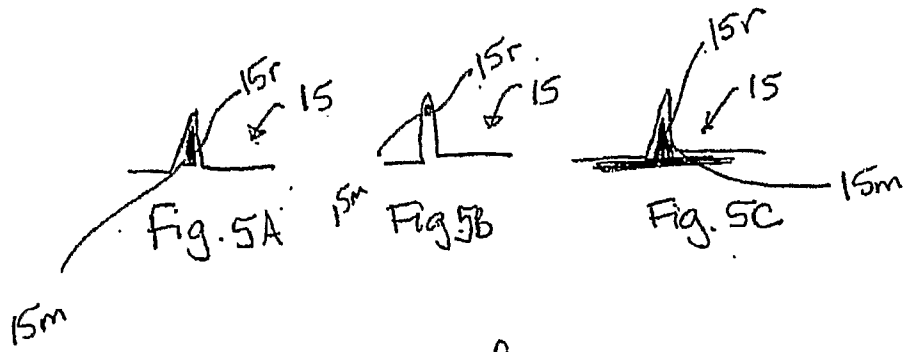

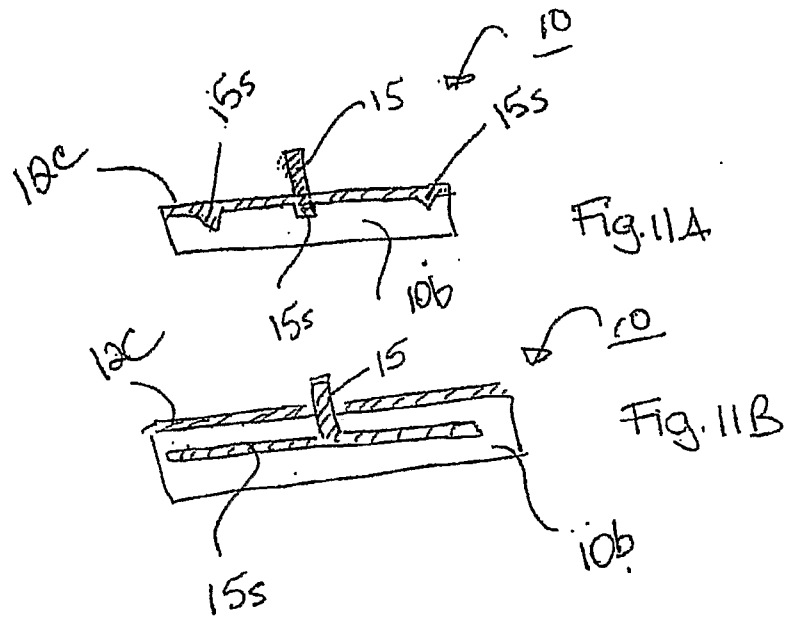

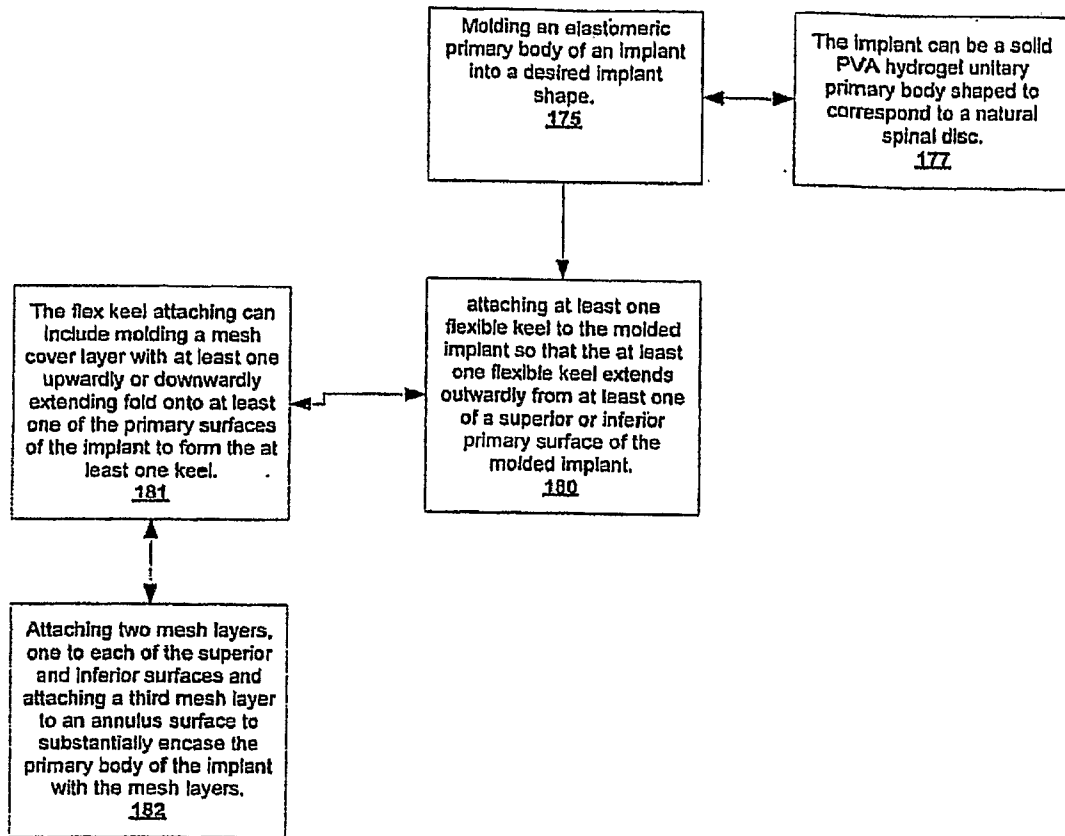
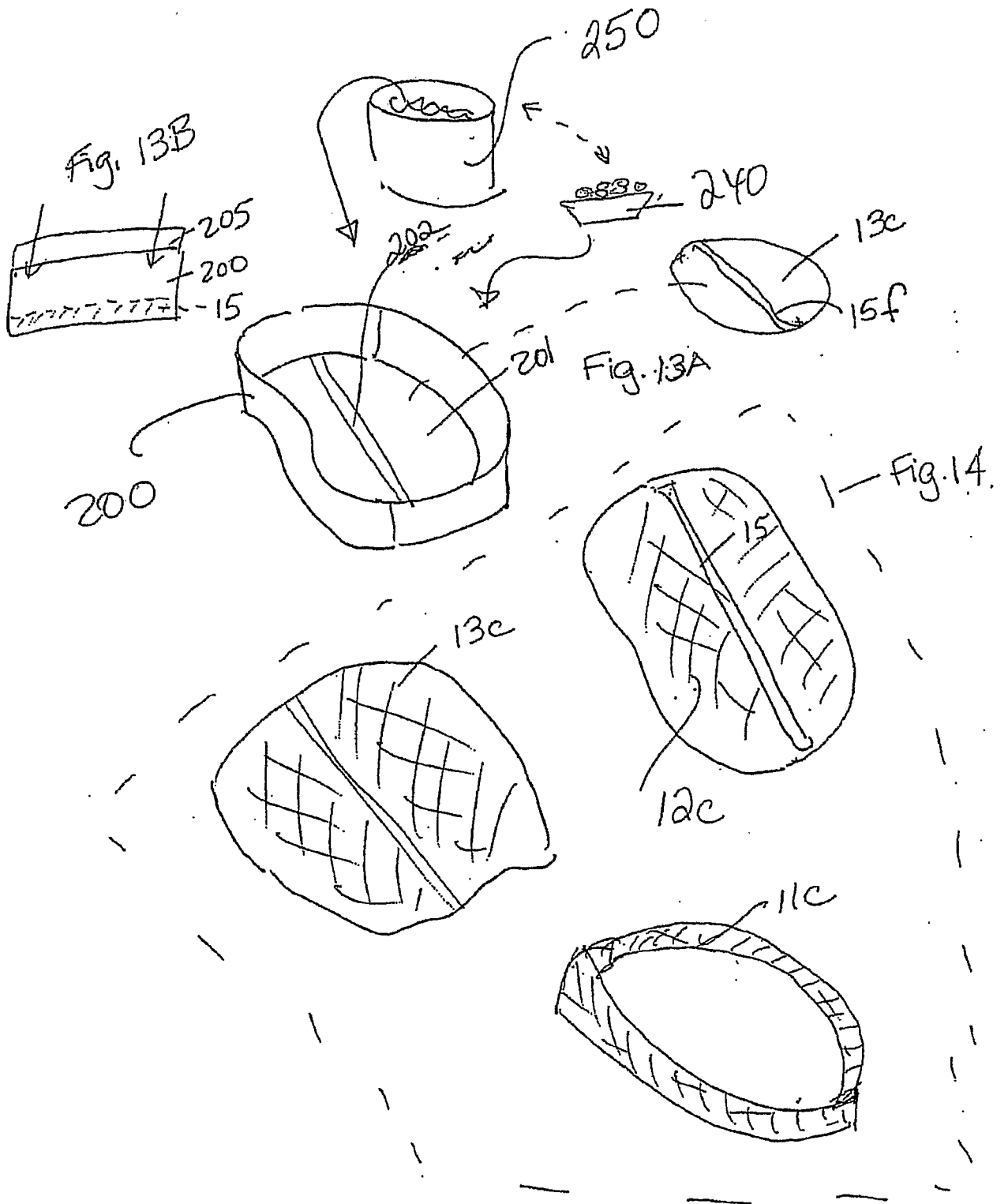

Fig.12





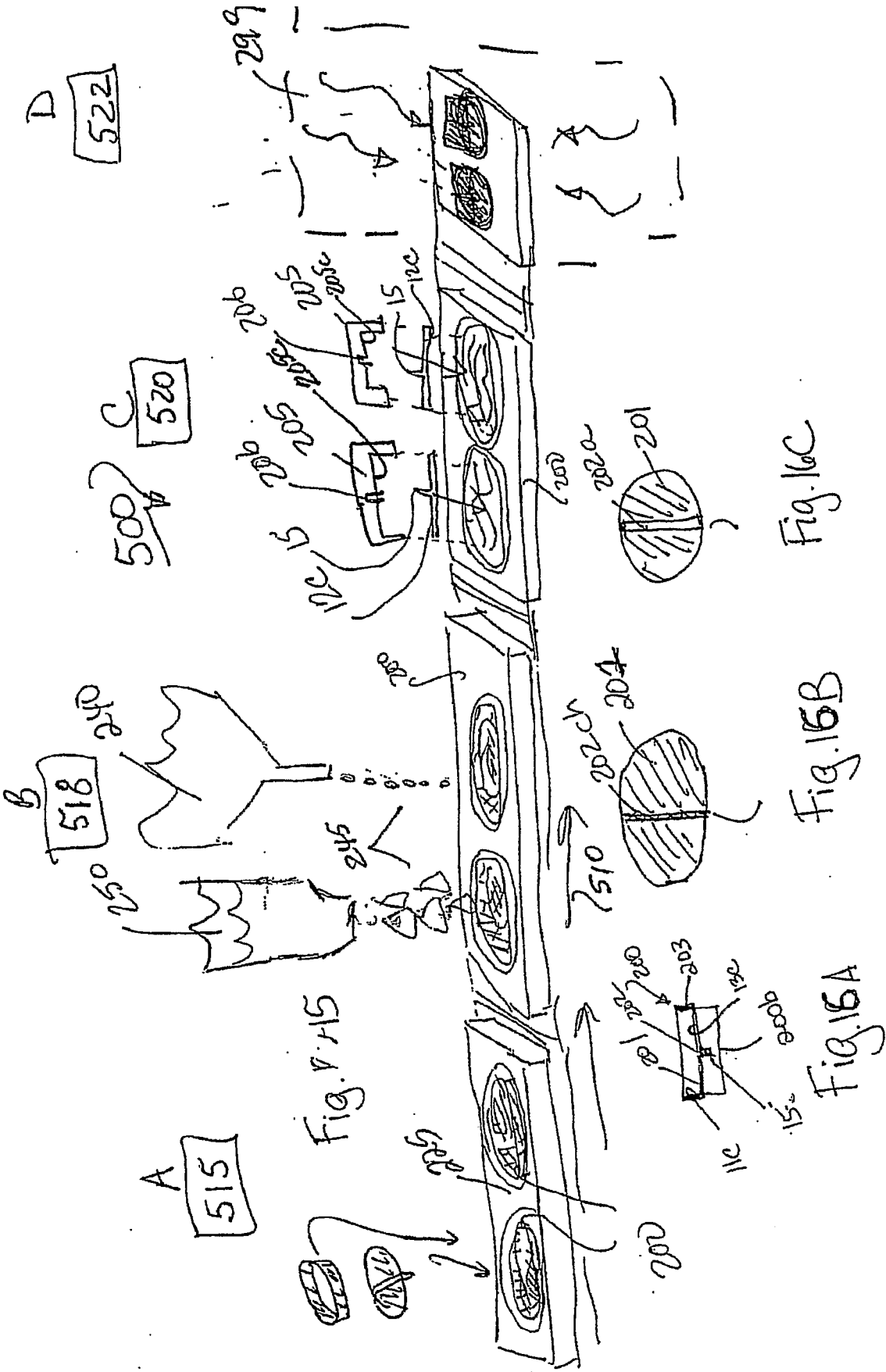

Fig. 15

Fig. 16C

Fig. 16B

Fig. 16A

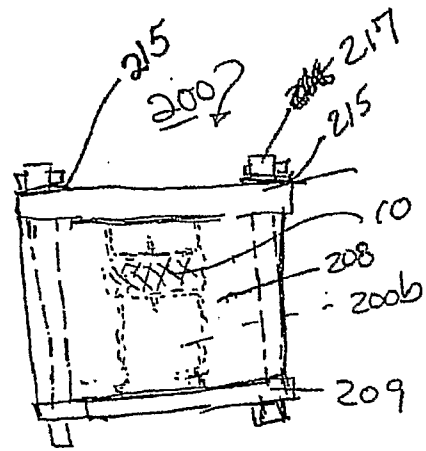
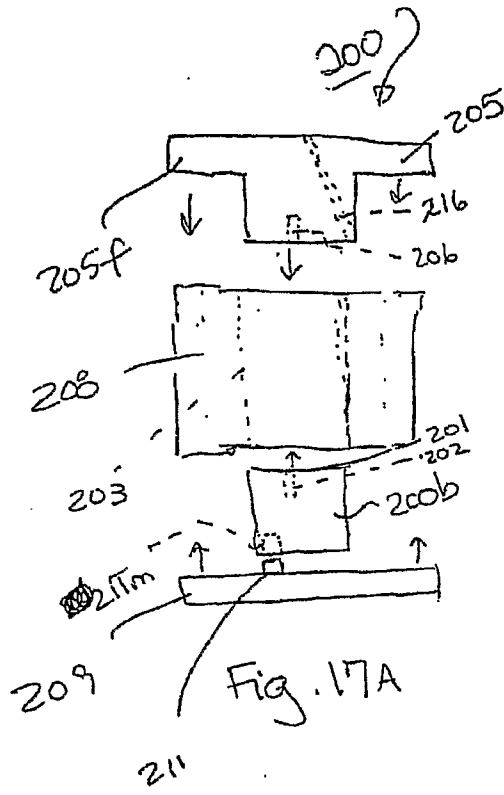
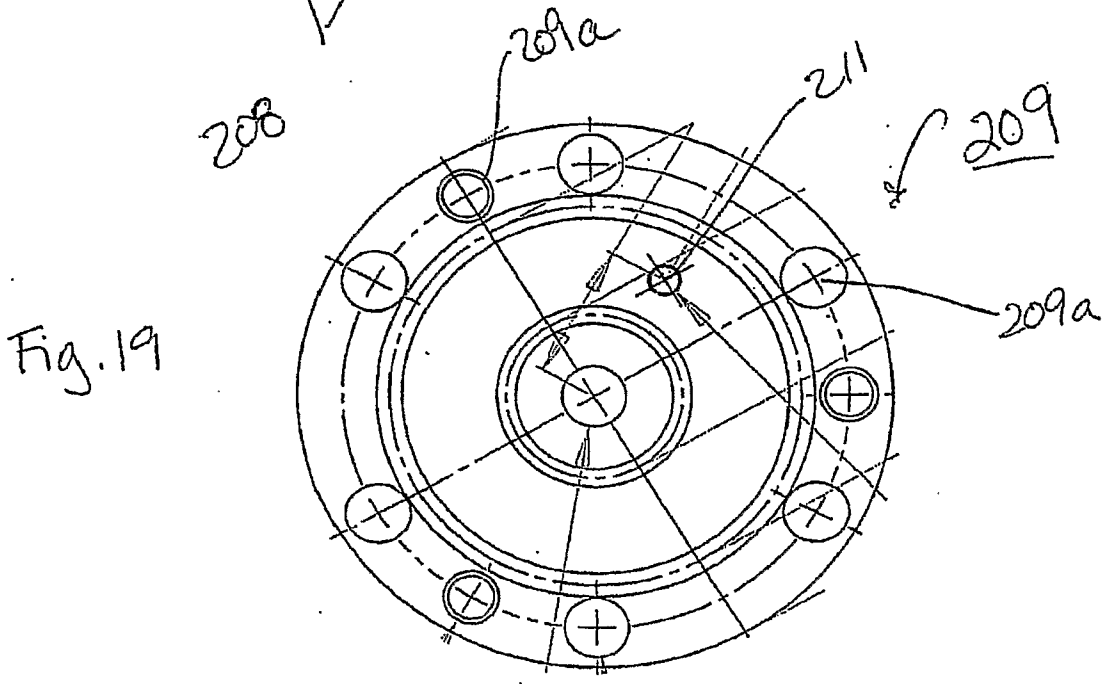
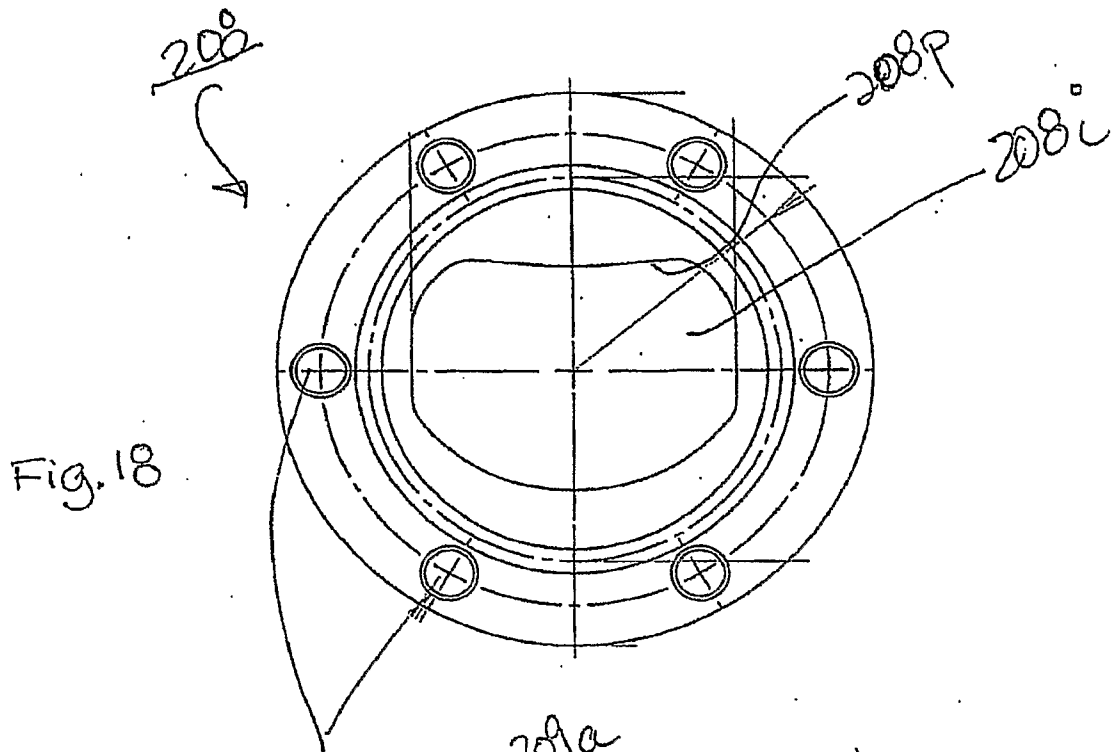

Fig. 17B



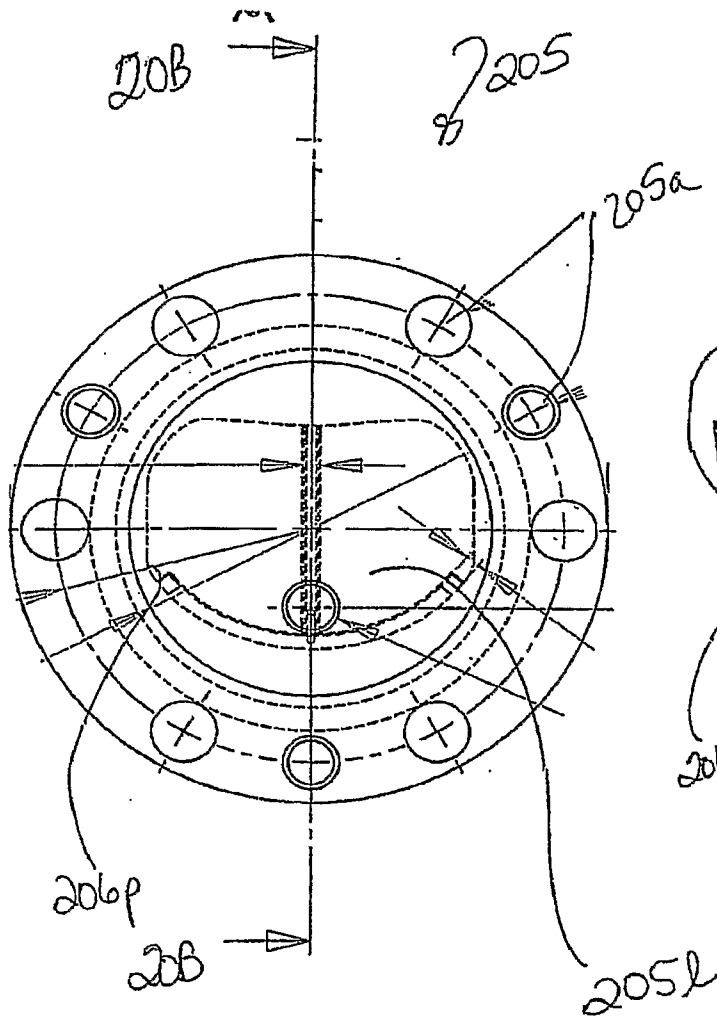

Fig. 20A

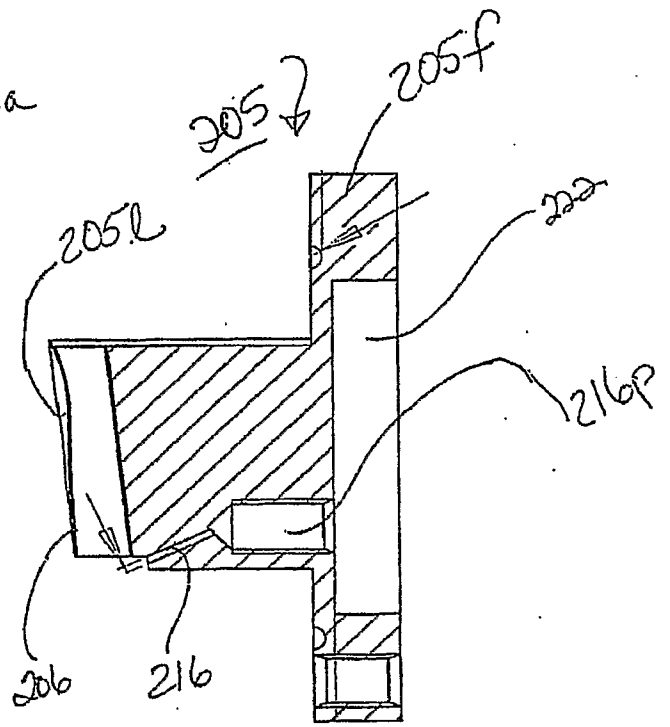

Fig. 20B

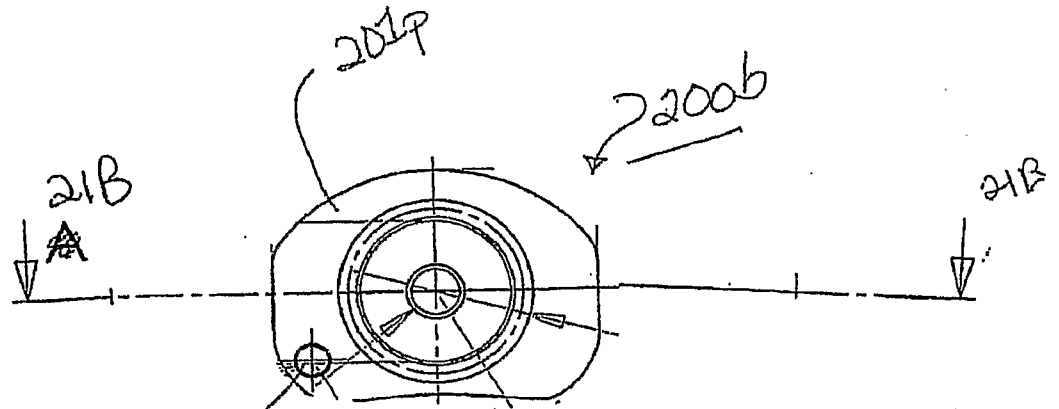

Fig. 21A

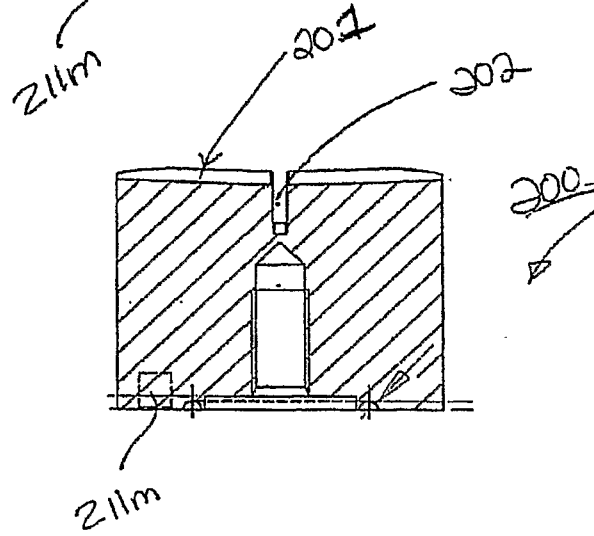

Fig. 21B

FIG. 22

