



- (51) **International Patent Classification:**
E21B 47/125 (2012.01) *E21B 47/12* (2012.01)
- (21) **International Application Number:**
PCT/US2013/022499
- (22) **International Filing Date:**
22 January 2013 (22.01.2013)
- (25) **Filing Language:** English
- (26) **Publication Language:** English
- (71) **Applicant:** HALLIBURTON ENERGY SERVICES, INC. [US/US]; 10200 Bellaire Boulevard, Houston, TX 77072 (US).
- (72) **Inventors:** SCOTT, Bruce, E.; 2601 Beltline Road, Carrollton, TX 75006 (US). GOIFFON, John, J.; 2601 Beltline Road, Carrollton, TX 75006 (US).
- (74) **Agent:** SMITH, Marlin, R.; Smith IP Services, P.C., P.O. Box 997, Rockwall, TX 75087 (US).
- (81) **Designated States** (*unless otherwise indicated, for every kind of national protection available*): AE, AG, AL, AM, AO, AT, AU, AZ, BA, BB, BG, BH, BN, BR, BW, BY, BZ, CA, CH, CL, CN, CO, CR, CU, CZ, DE, DK, DM, DO, DZ, EC, EE, EG, ES, FI, GB, GD, GE, GH, GM, GT,

HN, HR, HU, ID, IL, IN, IS, JP, KE, KG, KM, KN, KP, KR, KZ, LA, LC, LK, LR, LS, LT, LU, LY, MA, MD, ME, MG, MK, MN, MW, MX, MY, MZ, NA, NG, NI, NO, NZ, OM, PA, PE, PG, PH, PL, PT, QA, RO, RS, RU, RW, SC, SD, SE, SG, SK, SL, SM, ST, SV, SY, TH, TJ, TM, TN, TR, TT, TZ, UA, UG, US, UZ, VC, VN, ZA, ZM, ZW.

- (84) **Designated States** (*unless otherwise indicated, for every kind of regional protection available*): ARIPO (BW, GH, GM, KE, LR, LS, MW, MZ, NA, RW, SD, SL, SZ, TZ, UG, ZM, ZW), Eurasian (AM, AZ, BY, KG, KZ, RU, TJ, TM), European (AL, AT, BE, BG, CH, CY, CZ, DE, DK, EE, ES, FI, FR, GB, GR, HR, HU, IE, IS, IT, LT, LU, LV, MC, MK, MT, NL, NO, PL, PT, RO, RS, SE, SI, SK, SM, TR), OAPI (BF, BJ, CF, CG, CI, CM, GA, GN, GQ, GW, ML, MR, NE, SN, TD, TG).

Declarations under Rule 4.17:

- *as to applicant's entitlement to apply for and be granted a patent (Rule 4.17(ii))*

Published:

- *with international search report (Art. 21(3))*

(54) **Title:** CROSS-COMMUNICATION BETWEEN ELECTRONIC CIRCUITS AND ELECTRICAL DEVICES IN WELL TOOLS

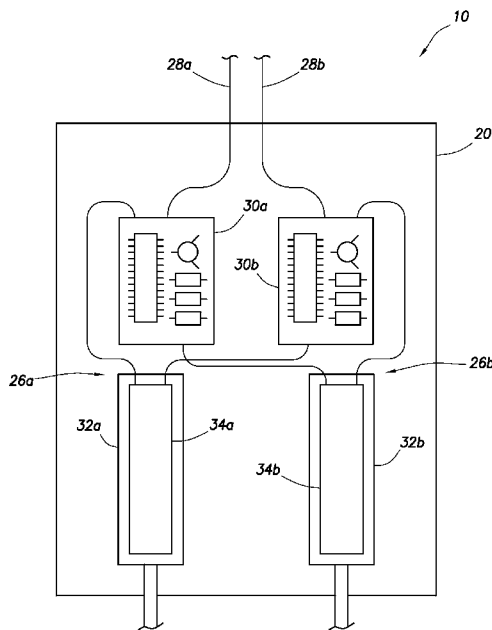

(57) **Abstract:** A well tool can include multiple electrical devices and multiple electronic circuits which control operation of the respective electrical devices, each electronic circuit including a respective isolation circuit, wherein each of the isolation circuits isolates a corresponding one of the electronic circuits from a respective one of the electrical devices in response to a predetermined condition. A method of operating a well tool can include providing multiple electronic circuits for operation of respective multiple electrical devices of the well tool, disconnecting one electronic circuit from its respective electrical device in the well, and connecting another electronic circuit to the electrical device in the well. Another method of operating a well tool can include providing multiple electronic circuits for operation of respective multiple electrical devices of the well tool, disconnecting one electronic circuit from its respective electrical device in the well, and connecting the electronic circuit to another electrical device.

WO 2014/116200 A1

5

**CROSS-COMMUNICATION BETWEEN ELECTRONIC CIRCUITS AND
ELECTRICAL DEVICES IN WELL TOOLS**

10

TECHNICAL FIELD

This disclosure relates generally to equipment utilized and operations performed in conjunction with a subterranean well and, in one example described below, more particularly provides for increased reliability through redundancy in well tools.

15

BACKGROUND

Subterranean wells are hostile environments for electrical components. Failure of an electrical component can cost many hours and much expense to remedy. Therefore, it will be appreciated that improvements are continually needed in the art of utilizing electrical components in well tools.

20

25

BRIEF DESCRIPTION OF THE DRAWINGS

FIG. 1 is a representative partially cross-sectional view of a well system and associated method which can embody principles of this disclosure.

- 2 -

FIG. 2 is a representative schematic view of an actuator section of a well tool.

FIG. 3 is a representative schematic view of a circuit diagram for redundantly operating multiple electrical devices via a single downhole electronic control circuit.

FIG. 4 is a representative schematic view of another example of the actuator section.

DETAILED DESCRIPTION

10 Representatively illustrated in FIG. 1 is a system 10 for use with a well, and an associated method, which system and method can embody principles of this disclosure. However, it should be clearly understood that the system 10 and method are merely one example of an application of the principles of this disclosure in practice, and a wide
15 variety of other examples are possible. Therefore, the scope of this disclosure is not limited at all to the details of the system 10 and method described herein and/or depicted in the drawings.

20 In the FIG. 1 example, a well tool 12 is connected in a tubular string 14 positioned in a wellbore 16. In the depicted example, the well tool 12 is of the type known to those skilled in the art as a safety valve 18 with a remotely controlled actuator section 20 for actuating the
25 valve to its open and closed configurations, in which flow through the tubular string 14 is respectively permitted and prevented.

However, the scope of this disclosure is not limited to use only with safety valves. Other types of well tools can
30 also benefit from the principles described herein.

- 3 -

As depicted in FIG. 1, the safety valve 18 includes an opening prong 22, which is displaced downward to pivot a flapper 24 to its open position, in which flow is permitted longitudinally through the safety valve. The opening prong
5 22 can be displaced upward to allow the flapper 24 to pivot to its closed position, in which at least upward flow is prevented through the safety valve.

The opening prong 22 is displaced by redundant actuators 26a,b of the actuator section 20. Although two
10 actuators 26a,b are depicted in FIG. 1, any number of actuators may be used, as desired.

The actuators 26a,b are redundant, in that either of them may be used to actuate the safety valve 18 by displacing the opening prong 22. A particular actuator 26a,b
15 is redundant, in that it can be used to displace the opening prong 22 in the event that another actuator is not available, whether or not the particular actuator was previously used for displacing the opening prong.

In the FIG. 1 example, the actuator section 20 is
20 controlled via lines 28 extending to a remote location (such as, the earth's surface, a subsea location, etc.). In other examples, the actuator section 20 could be controlled via wireless telemetry, or it could be controlled locally. The scope of this disclosure is not limited to any particular
25 well tool control location or means.

Referring additionally now to FIG. 2, an example of the actuator section 20 is representatively illustrated, apart from the remainder of the well tool 12. In this example, it may be seen that each of the actuators 26a,b includes an
30 electronic circuit 30a,b for controlling operation of a respective electrical device 32a,b.

- 4 -

The electrical devices 32a,b comprise motors in this example, with each motor having an associated motor winding 34a,b. However, in other examples the electrical devices 32a,b could be other types of electrical devices, such as, 5 electrical brakes, clutches, valves, etc.

In normal operation, electronic circuit 30a is used to control operation of the device 32a, and electronic circuit 30b is used to control operation of device 32b. However, the electronic circuit 30a can be used to operate the device 10 34b, and the electronic circuit 30b can be used to operate the device 32a.

Referring additionally now to FIG. 3, the electronic circuit 30a is representatively illustrated in schematic form. In this view, it may be seen that the electronic 15 circuit 30a includes a driver circuit 36 and an isolation circuit 38. The other electronic circuit 30b is preferably similarly configured.

The isolation circuit 38 can isolate the motor windings 34a,b (and any other common actuator windings) from the 20 driver circuit 36 if the driver circuit fails. In addition, the isolation circuit 38 can isolate the driver circuit 36 from a failed motor winding 34a,b.

The isolation circuit 38 can be triggered by excessive current draw by the respective device 32a,b, excessive 25 voltage across the respective device, or in response to a command generated remotely or locally. The isolation circuit 38 can isolate the output of an electronic circuit 30a,b from its respective electrical device 32a,b or it can isolate only a driver circuit 36 that has failed, for 30 example, a motor driver circuit, etc.

The electronic circuits 30a,b, thus, have multiple outputs and the isolation circuits 38 that allow the

- 5 -

electronic circuits 30a,b to switch electrical power from one output to another as needed. This switching is not necessarily permanent. The switching can be software or hardware driven. Preferably, the switching of the outputs
5 would be initiated by a command from a remote location, and in response the downhole electronic circuits 30a,b performing the actual switching.

For example, if the electronic circuit 30b fails (e.g., the driver circuit 36 thereof fails), but the electrical
10 device 32b can still be used to actuate the well tool 12, the isolation circuit 38 of the electronic circuit 30b can disconnect the driver circuit 36 of the electronic circuit 30b from the device 32b, and the isolation circuit of the electronic circuit 30a can connect the driver circuit of the
15 electronic circuit 30a to the device 32b, so that the electronic circuit 30a can be used to operate the device 32b. Such a change could be performed automatically in response to the failure of the electronic circuit 30b, or in response to a command generated remotely or locally.

20 Similarly, if the electronic circuit 30a fails (e.g., the driver circuit 36 thereof fails), but the electrical device 32a can still be used to actuate the well tool 12, the isolation circuit 38 of the electronic circuit 30a can disconnect the driver circuit 36 of the electronic circuit
25 30a from the device 32a, and the isolation circuit of the electronic circuit 30b can connect the driver circuit of the electronic circuit 30b to the device 32a, so that the electronic circuit 30b can be used to operate the device 32a. Such a change could be performed automatically in
30 response to the failure of the electronic circuit 30a, or in response to a command generated remotely or locally.

- 6 -

Thus, if either of the electronic circuits 30a,b fails, the electrical device 32a,b formerly operated by the failed electronic circuit can instead be operated by the still operational one of the electronic circuits. The failed one
5 of the electronic circuits 30a,b is effectively isolated from its respective electrical device 32a,b in this situation.

In some situations, only a portion of an electronic circuit 30a,b may fail that prevents the respective one of
10 the actuators 26a,b from being operated. For example, a motor driver circuit, a clutch driver circuit, etc., may fail, without resulting in an increase in current draw by the respective actuator 26a,b.

In those situations, a voltage greater than a normal
15 operating voltage could be transmitted via a respective line 28a,b from the surface. This would trigger an isolation circuit 38 that is driven by a voltage. Upon triggering the isolation circuit 38 with the overvoltage, the electronic circuit 30a and actuator 26a would disconnect, similar to
20 the previous example.

In some situations, portions of an electronic circuit 30a,b may be functioning, but the respective device 32a,b cannot be operated. In those situations, and others, a
25 command could be sent from the surface to activate the associated isolation circuit 38, thereby isolating the electronic circuit 30a,b, in total or in part.

The isolation circuit 38 can comprise, in some
examples, a switch type circuit for selectively connecting and disconnecting the driver circuit 36 and/or other
30 portions of the associated electronic circuit 30a,b to its respective electrical device 32a,b. The isolation circuit 38

- 7 -

can be similar to a normally closed transistor(s), which is open when activated.

Referring additionally now to FIG. 4, another example of the actuator section 20 is representatively illustrated.

5 In this example, each of the devices 32a,b includes multiple windings 34a,b. Each electronic circuit 30a,b can be used to control electrical power delivery to the respective windings 34a,b in both of the devices 32a,b.

10 In the event of a failure of either electronic circuit 30a,b, an isolation circuit 38 does not have to be activated, but power to the failed electronic circuit 30a,b should preferably be disconnected. If power to the failed circuit 30a,b is not turned off, the respective device 32a,b could have residual magnetism from current in the circuit
15 30a,b which may prevent the device from operating properly.

It may now be fully appreciated that significant advancements are provided to the art by the above disclosure. In examples described above, multiple well tool actuators 26a,b can be operated redundantly, even though an
20 electronic circuit 30a,b or an electrical device 32a,b thereof fails.

A well tool 12 is provided to the art by the above disclosure, In one example, the well tool 12 can include at least first and second electrical devices 32a,b, at least
25 first and second electronic circuits 30a,b which control operation of the respective first and second electrical devices 32a,b, the first and second electronic circuits 30a,b including at least respective first and second isolation circuits 38, wherein each of the first and second
30 isolation circuits 38 isolates a corresponding one of the first and second electronic circuits 30a,b from a respective

one of the first and second electrical devices 32a,b in response to a predetermined condition.

Each of the first and second isolation circuits 38 may connect the corresponding one of the first and second
5 electronic circuits 30a,b to an opposite one of the first and second electrical devices 32a,b in response to the predetermined condition.

The predetermined condition can comprise current draw by the respective one of the first and second electrical
10 devices 32a,b greater than a predetermined threshold, voltage across the respective one of the first and second electrical devices 32a,b greater than a predetermined threshold, a predetermined signal transmitted from a remote location (for example, via the lines 28), and/or a failure
15 of the respective one of the first and second electrical devices 32a,b.

The first and second electrical devices 32a,b may comprise motor windings. The first and second electrical devices 32a,b may actuate the well tool 12 positioned in a
20 subterranean well.

A method of operating a well tool 12 in a subterranean well is also described above. In one example, the method can comprise: providing first and second electronic circuits
30a,b for operation of respective first and second
25 electrical devices 32a,b of the well tool 12; disconnecting the first electronic circuit 30a from the first electrical device 32a in the well; and connecting the second electronic circuit 30b to the first electrical device 32a in the well.

The method can include isolating the first electronic
30 circuit 30a from the second electrical device 32b.

The method can include operating the second electrical device 32b with the second electronic circuit 30b.

The method can include operating the first and second electrical devices 32a,b with the second electronic circuit
5 30b.

The disconnecting step can be performed in response to a predetermined condition. The predetermined condition may comprise a failure of the first electronic circuit 30a.

Each of the first and second electrical devices 32a,b
10 may comprise multiple motor windings 34a,b.

Another method of operating a well tool 12 in a subterranean well can comprise: providing first and second electronic circuits 30a,b for operation of respective first and second electrical devices 32a,b of the well tool 12;
15 disconnecting the first electronic circuit 30a from the first electrical device 32a in the well; and connecting the first electronic circuit 30a to the second electrical device 32b in the well.

The method can include, prior to the connecting the
20 first electronic circuit 30a to the second electrical device 32b: operating the second electrical device 32b with the second electronic circuit 30b and then disconnecting the second electronic circuit 30b from the second electrical device 32b in the well.

25 The step of connecting the first electronic circuit 30a to the second electrical device 32b can include connecting the first electronic circuit 30a to a first one of multiple motor windings 34a,b of the second electrical device 32b. The method can also include operating the second electrical
30 device 32b with the second electronic circuit 30b connected to a second one of the multiple motor windings 34a,b.

- 10 -

The disconnecting step may be performed in response to a predetermined condition. The predetermined condition can comprise a failure of the first electrical device 32a, current draw by the first electrical device 32a greater than a predetermined threshold, voltage across the first
5 electrical device 32a greater than a predetermined threshold, and/or a predetermined signal transmitted from a remote location.

Although various examples have been described above,
10 with each example having certain features, it should be understood that it is not necessary for a particular feature of one example to be used exclusively with that example. Instead, any of the features described above and/or depicted in the drawings can be combined with any of the examples, in
15 addition to or in substitution for any of the other features of those examples. One example's features are not mutually exclusive to another example's features. Instead, the scope of this disclosure encompasses any combination of any of the features.

20 Although each example described above includes a certain combination of features, it should be understood that it is not necessary for all features of an example to be used. Instead, any of the features described above can be used, without any other particular feature or features also
25 being used.

It should be understood that the various embodiments described herein may be utilized in various orientations, such as inclined, inverted, horizontal, vertical, etc., and in various configurations, without departing from the
30 principles of this disclosure. The embodiments are described merely as examples of useful applications of the principles

of the disclosure, which is not limited to any specific details of these embodiments.

In the above description of the representative examples, directional terms (such as "above," "below," "upper," "lower," etc.) are used for convenience in referring to the accompanying drawings. However, it should be clearly understood that the scope of this disclosure is not limited to any particular directions described herein.

The terms "including," "includes," "comprising," "comprises," and similar terms are used in a non-limiting sense in this specification. For example, if a system, method, apparatus, device, etc., is described as "including" a certain feature or element, the system, method, apparatus, device, etc., can include that feature or element, and can also include other features or elements. Similarly, the term "comprises" is considered to mean "comprises, but is not limited to."

Of course, a person skilled in the art would, upon a careful consideration of the above description of representative embodiments of the disclosure, readily appreciate that many modifications, additions, substitutions, deletions, and other changes may be made to the specific embodiments, and such changes are contemplated by the principles of this disclosure. For example, structures disclosed as being separately formed can, in other examples, be integrally formed and *vice versa*. Accordingly, the foregoing detailed description is to be clearly understood as being given by way of illustration and example only, the spirit and scope of the invention being limited solely by the appended claims and their equivalents.

WHAT IS CLAIMED IS:

1. A well tool, comprising:

at least first and second electrical devices; and

5 at least first and second electronic circuits which control operation of the respective first and second electrical devices, the first and second electronic circuits including at least respective first and second isolation circuits, wherein each of the first and second isolation
10 circuits isolates a corresponding one of the first and second electronic circuits from a respective one of the first and second electrical devices in response to a predetermined condition.

15 2. The well tool of claim 1, wherein each of the first and second isolation circuits connects the corresponding one of the first and second electronic circuits to an opposite one of the first and second electrical devices in response to the predetermined
20 condition.

3. The well tool of claim 1, wherein the predetermined condition comprises current draw by the respective one of the first and second electrical devices
25 greater than a predetermined threshold.

4. The well tool of claim 1, wherein the predetermined condition comprises voltage across the respective one of the first and second electrical devices
30 greater than a predetermined threshold.

5. The well tool of claim 1, wherein the predetermined condition comprises a predetermined signal transmitted from a remote location.

5

6. The well tool of claim 1, wherein the predetermined condition comprises a failure of the respective one of the first and second electrical devices.

10 7. The well tool of claim 1, wherein the first and second electrical devices comprise motor windings.

15 8. The well tool of claim 1, wherein the first and second electrical devices actuate the well tool positioned in a subterranean well.

- 14 -

9. A method of operating a well tool in a subterranean well, the method comprising:

providing first and second electronic circuits for operation of respective first and second electrical devices
5 of the well tool;

disconnecting the first electronic circuit from the first electrical device in the well; and

connecting the second electronic circuit to the first electrical device in the well.

10

10. The method of claim 9, further comprising isolating the first electronic circuit from the second electrical device.

15

11. The method of claim 9, further comprising operating the second electrical device with the second electronic circuit.

20

12. The method of claim 9, further comprising operating the first and second electrical devices with the second electronic circuit.

25

13. The method of claim 9, wherein the disconnecting is performed in response to a predetermined condition.

14. The method of claim 13, wherein the predetermined condition comprises a failure of the first electronic circuit.

15. The method of claim 9, wherein the first and second electrical devices comprise motor windings.

16. The method of claim 9, wherein each of the first
5 and second electrical devices comprises multiple motor windings.

- 16 -

17. A method of operating a well tool in a subterranean well, the method comprising:

providing first and second electronic circuits for operation of respective first and second electrical devices
5 of the well tool;

disconnecting the first electronic circuit from the first electrical device in the well; and

connecting the first electronic circuit to the second electrical device in the well.

10

18. The method of claim 17, further comprising, prior to the connecting the first electronic circuit to the second electrical device: operating the second electrical device with the second electronic circuit and then disconnecting
15 the second electronic circuit from the second electrical device in the well.

19. The method of claim 17, wherein connecting the first electronic circuit to the second electrical device
20 further comprises connecting the first electronic circuit to a first one of multiple motor windings of the second electrical device.

20. The method of claim 19, further comprising
25 operating the second electrical device with the second electronic circuit connected to a second one of the multiple motor windings.

21. The method of claim 17, wherein the disconnecting
30 is performed in response to a predetermined condition.

22. The method of claim 21, wherein the predetermined condition comprises a failure of the first electrical device.

5

23. The method of claim 21, wherein the predetermined condition comprises current draw by the first electrical device greater than a predetermined threshold.

10

24. The method of claim 21, wherein the predetermined condition comprises voltage across the first electrical device greater than a predetermined threshold.

15

25. The method of claim 21, wherein the predetermined condition comprises a predetermined signal transmitted from a remote location.

20

26. The method of claim 17, wherein the first and second electrical devices comprise motor windings.

27. The method of claim 17, wherein each of the first and second electrical devices comprises multiple motor windings.

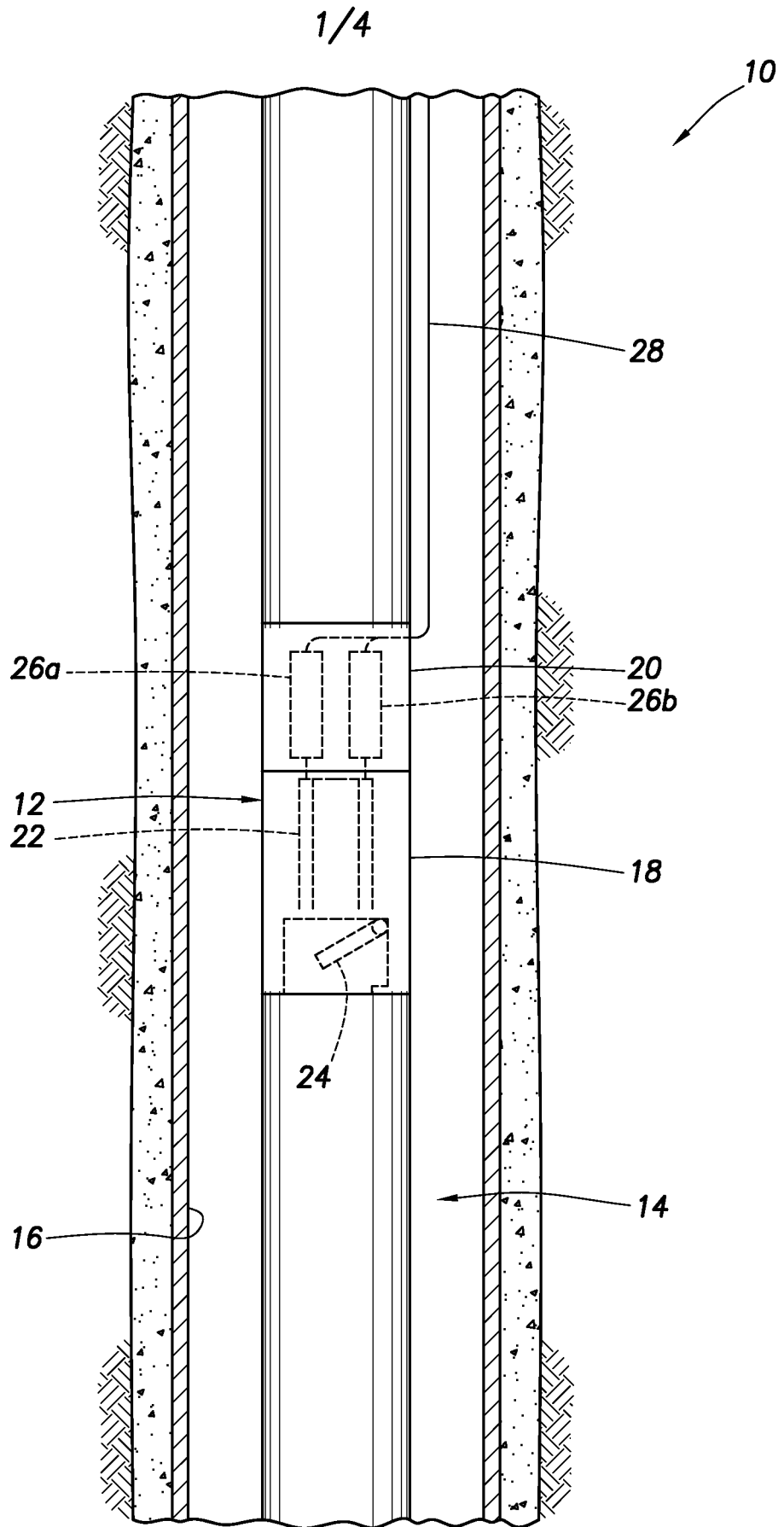

FIG. 1

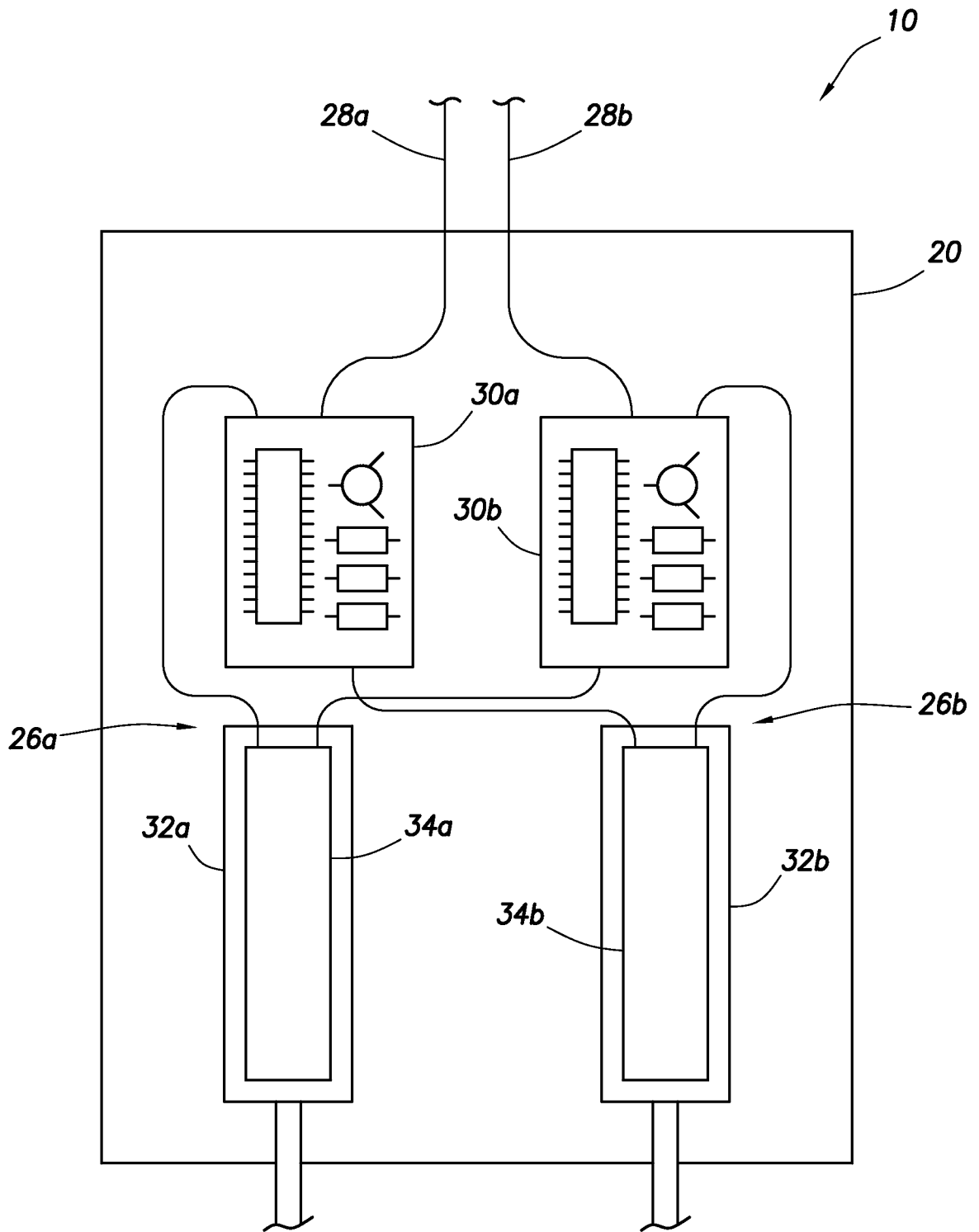

FIG.2

3/4

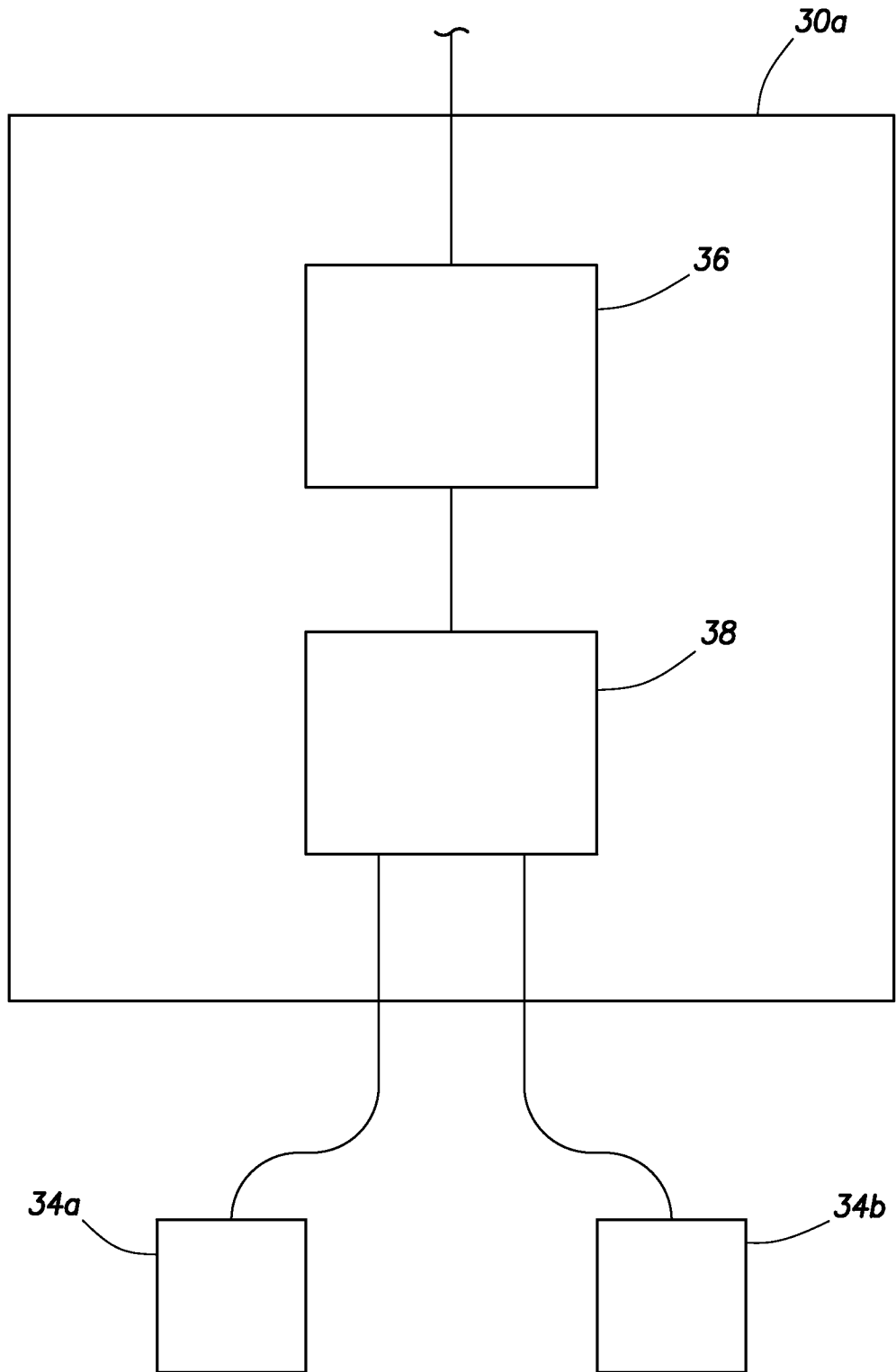

FIG.3

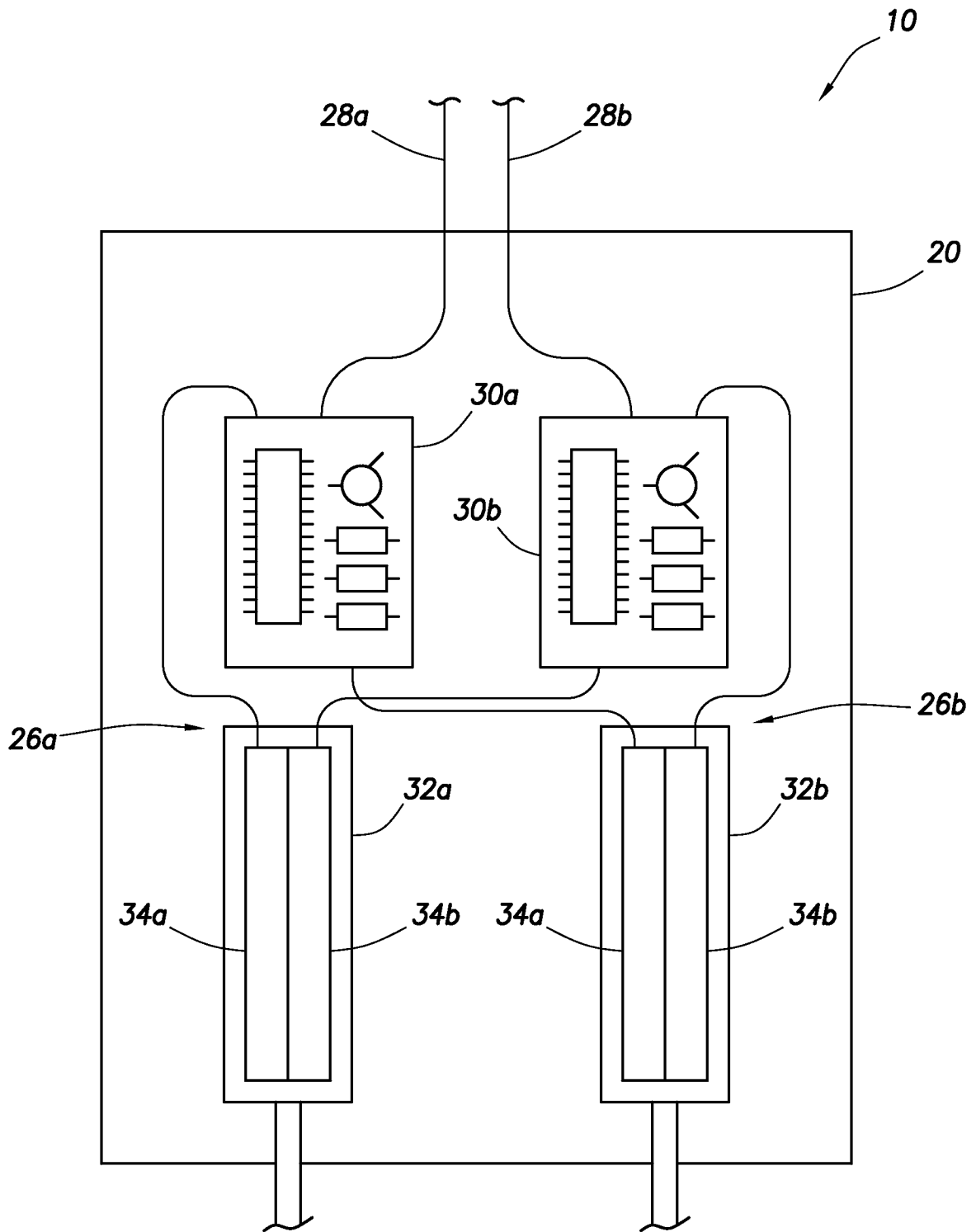

FIG.4

INTERNATIONAL SEARCH REPORT

International application No.
PCT/US2013/022499**A. CLASSIFICATION OF SUBJECT MATTER****E21B 47/125(2012.01)i, E21B 47/12(2006.01)i**

According to International Patent Classification (IPC) or to both national classification and IPC

B. FIELDS SEARCHEDMinimum documentation searched (classification system followed by classification symbols)
E21B 47/125; E21B 43/1185; H04H 9/00; H02H 3/00; E21B 33/122; H04B 3/36Documentation searched other than minimum documentation to the extent that such documents are included in the fields searched
Korean utility models and applications for utility models
Japanese utility models and applications for utility modelsElectronic data base consulted during the international search (name of data base and, where practicable, search terms used)
eKOMPASS(KIPO internal) & Keywords: first, second, isolation, circuit and predetermined-condition**C. DOCUMENTS CONSIDERED TO BE RELEVANT**

Category*	Citation of document, with indication, where appropriate, of the relevant passages	Relevant to claim No.
A	US 2011-0176584 A1 (KIKUCHI et al.) 21 July 2011 See paragraphs [0010],[0033],[0045] and figure 1.	1-27
A	US 2003-0213595 A1 (JACKSON, CAMERON) 20 November 2003 See paragraphs [0005]-[0022] and figure 8.	1-27
A	US 6920085 B2 (FINKE et al.) 19 July 2005 See claim 1 and figure 2.	1-27
A	US 6003601 A (LONGBOTTOM, JAMES R.) 21 December 1999 See claims 1,8 and figure 1.	1-27
A	US 5801913 A (PITTEL, ARKADY) 01 September 1998 See claims 1,12 and figure 1.	1-27

 Further documents are listed in the continuation of Box C. See patent family annex.

* Special categories of cited documents:

"A" document defining the general state of the art which is not considered to be of particular relevance

"E" earlier application or patent but published on or after the international filing date

"L" document which may throw doubts on priority claim(s) or which is cited to establish the publication date of citation or other special reason (as specified)

"O" document referring to an oral disclosure, use, exhibition or other means

"P" document published prior to the international filing date but later than the priority date claimed

"T" later document published after the international filing date or priority date and not in conflict with the application but cited to understand the principle or theory underlying the invention

"X" document of particular relevance; the claimed invention cannot be considered novel or cannot be considered to involve an inventive step when the document is taken alone

"Y" document of particular relevance; the claimed invention cannot be considered to involve an inventive step when the document is combined with one or more other such documents, such combination being obvious to a person skilled in the art

"&" document member of the same patent family

Date of the actual completion of the international search

15 October 2013 (15.10.2013)

Date of mailing of the international search report

15 October 2013 (15.10.2013)

Name and mailing address of the ISA/KR

Korean Intellectual Property Office
189 Cheongsu-ro, Seo-gu, Daejeon Metropolitan City,
302-701, Republic of Korea

Facsimile No. +82-42-472-7140

Authorized officer

CHOI Hyun Goo

Telephone No. +82-42-481-8288



INTERNATIONAL SEARCH REPORT

Information on patent family members

International application No.

PCT/US2013/022499

Patent document cited in search report	Publication date	Patent family member(s)	Publication date
US 2011-0176584 A1	21/07/2011	JP 2011-151557 A	04/08/2011
US 2003-0213595 A1	20/11/2003	AU 2003-239470 A1	02/12/2003
		CA 2485664 A1	27/11/2003
		CA 2485664 C	12/07/2011
		DE 60315157 D1	06/09/2007
		DK 1511912T3	29/10/2007
		EP 1511912 A2	09/03/2005
		EP 1511912 B1	25/07/2007
		MX PA04011314 A	17/02/2005
		US 6779605 B2	24/08/2004
		WO 2003-098153 A2	27/11/2003
		WO 2003-098153 A3	22/07/2004
US 6920085 B2	19/07/2005	AU 2002-243991 B2	10/08/2006
		CA 2438139 A1	22/08/2002
		CA 2438139 C	12/05/2009
		CA 2538303 A1	22/08/2002
		CA 2538303 C	16/06/2009
		CA 2538307 A1	22/08/2002
		CA 2538307 C	22/12/2009
		CA 2538310 A1	22/08/2002
		CA 2538310 C	13/04/2010
		CA 2691720 A1	22/08/2002
		CA 2691720 C	02/04/2013
		CA 2802235 A1	22/08/2002
		GB 0321201 D0	08/10/2003
		GB 0514589 D0	24/08/2005
		GB 0514590 D0	24/08/2005
		GB 2390864 A	21/01/2004
		GB 2390864 B	11/05/2005
		GB 2407597 A	04/05/2005
		GB 2413138 A	19/10/2005
		GB 2413138 B	22/02/2006
		GB 2413578 A	02/11/2005
		GB 2413578 A8	08/08/2006
		GB 2413578 B	28/06/2006
		GB 2413578 B8	08/08/2006
		NO 20033595 A	19/09/2003
		NO 20033595 D0	13/08/2003
		US 2003-0016164 A1	23/01/2003
		WO 02-065158 A1	22/08/2002
US 6003601 A	21/12/1999	CA 2229091 A1	13/08/1998
		CA 2229091 C	13/08/1998
		CA 2229091 C	09/11/2004
		EP 0859122 A2	19/08/1998
		EP 0859122 A3	06/03/2002
		EP 0859122 B1	18/05/2005

INTERNATIONAL SEARCH REPORT

Information on patent family members

International application No.

PCT/US2013/022499

Patent document cited in search report	Publication date	Patent family member(s)	Publication date
		EP 1559866 A1	03/08/2005
		EP 1559866 B1	09/01/2008
		EP 1712727 A1	18/10/2006
		US 05845707 A	08/12/1998
		US 05954134 A	21/09/1999
US 5801913 A	01/09/1998	None	