

(12) STANDARD PATENT
(19) AUSTRALIAN PATENT OFFICE

(11) Application No. **AU 2004244652 B2**

(54) Title
Trapped gas removal in liquid-gas accumulator

(51) International Patent Classification(s)
F15B 1/08 (2006.01) **F15B 1/16** (2006.01)
F15B 1/10 (2006.01) **F15B 21/04** (2006.01)

(21) Application No: **2004244652** (22) Date of Filing: **2004.12.24**

(30) Priority Data

(31) Number	(32) Date	(33) Country
10/752209	2004.01.06	US

(43) Publication Date: **2005.07.21**

(43) Publication Journal Date: **2005.07.21**

(44) Accepted Journal Date: **2011.09.29**

(71) Applicant(s)
Eaton Corporation

(72) Inventor(s)
Draper, Don R.

(74) Agent / Attorney
FB Rice, Level 23 200 Queen Street, Melbourne, VIC, 3000

(56) Related Art
GB 2104964
US 2002/096223

ABSTRACT OF THE DISCLOSURE

A hydraulic accumulator of the liquid-gas type, comprising a rigid housing (11) defining an internal chamber (11C) and a gas port (30) and a liquid port (19).

- 5 A gas charging valve (31) is disposed in the gas port (30) to control the admission of high pressure gas. A deformable, semi-permeable separator (35) is disposed within the housing (11) to separate said internal chamber (11C) into a gas chamber (33) in communication with the gas port (30), and a liquid chamber (21) in communication with the liquid port (19). A means (41)
- 10 is disposed within the liquid chamber (21) for receiving and collecting gas which passes from the gas chamber (33), through the semi-permeable separator (35), and into said liquid chamber (21). Also included is a conduit means (45) having one end (45a) in fluid communication with the gas collecting means (41), and another end (45b) operably associated with the housing (11,27) to communicate
- 15 gas from the gas collecting means (41) out of said liquid chamber (21).

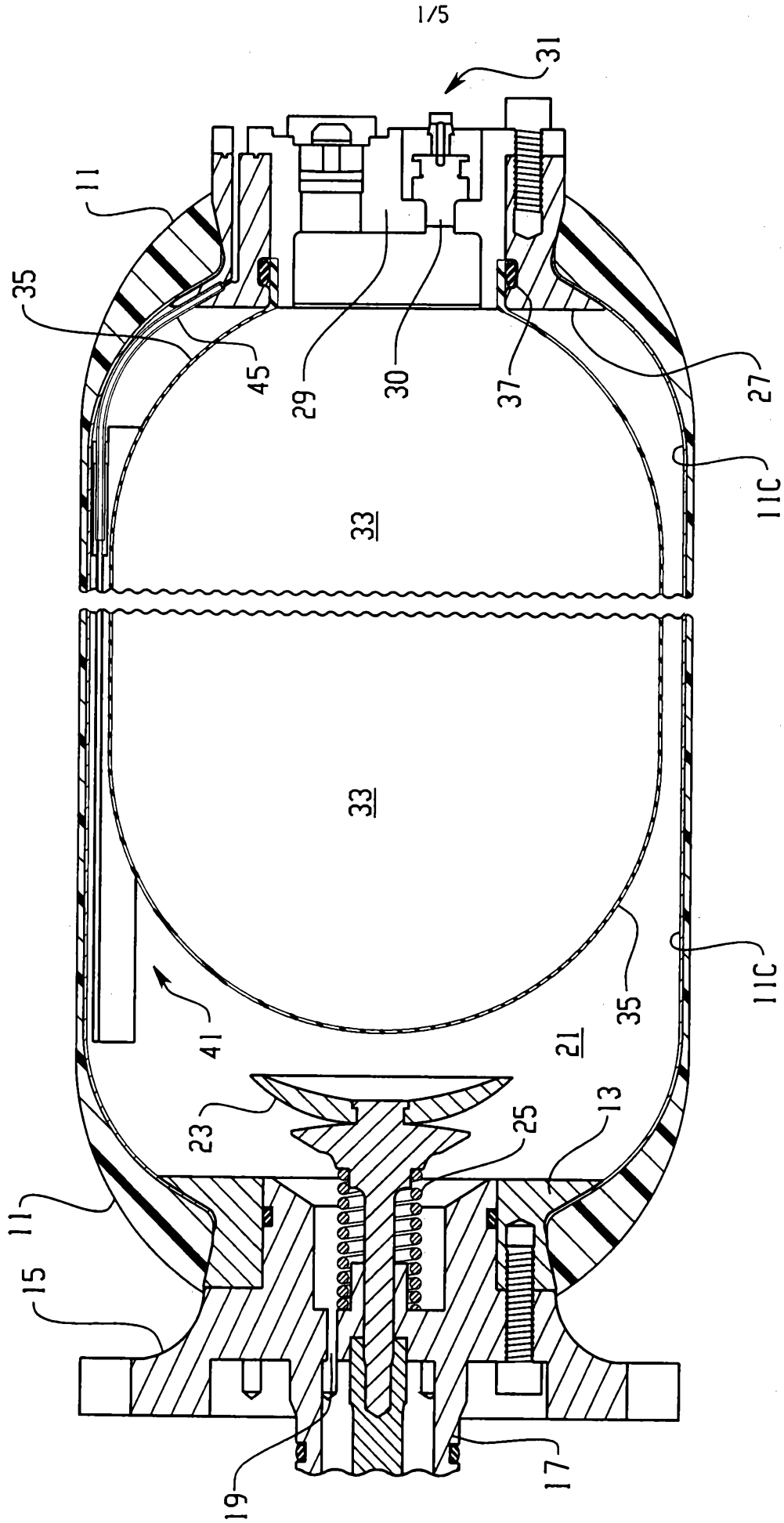

Fig. 1

AUSTRALIA
Patents Act 1990

EATON CORPORATION

COMPLETE SPECIFICATION
STANDARD PATENT

Invention Title:

Trapped gas removal in liquid-gas accumulator

The following statement is a full description of this invention including the best method of performing it known to us:-

BACKGROUND OF THE DISCLOSURE

The present invention relates to hydraulic accumulators of the liquid-gas type, and more particularly, to such accumulators of the type having a separator between the gas chamber and the liquid chamber, wherein the separator is at least somewhat permeable
5 with respect to the gas.

Liquid-gas accumulators, of the type to which the present invention relates, are now generally well known to those skilled in the art, an example of such an accumulator being shown in U.S. Patent No. 5,520,208, incorporated herein by reference.

A typical liquid-gas hydraulic accumulator is used as a hydraulic energy storage
10 device, wherein the accumulator may be "pumped up" with hydraulic fluid (the "liquid") by displacing the gas volume with hydraulic fluid. The gas pressure within the accumulator rises, in accordance with the physical properties of the gas being used, and is approximately equal to the pressure of the liquid within the accumulator. Subsequently, when hydraulic pressure is required somewhere in the hydraulic circuit with which the
15 accumulator is associated, a control device (such as a valve) will open, thus releasing the stored hydraulic energy, to provide pressurized flow within the circuit.

In the typical hydraulic accumulator of the type to which the present invention relates, there is a rigid outer shell (or "housing") defining an internal chamber, and some sort of separator is disposed within the chamber, dividing it into a liquid chamber and a gas
20 chamber. As is also typical, the liquid chamber is in communication with the external hydraulic circuit by means of a hydraulic port and conduit, which may or may not contain a valve assembly, while the gas chamber is able to receive high pressure gas from a source of pressurized gas, through a gas charging valve. Typically, the gas is some form of a relatively inert gas, such as a nitrogen gas, although it should be understood that the
25 present invention is not limited to the use of any particular type of gas.

In the conventional hydraulic accumulator of the liquid-gas type, the separator between the liquid chamber and the gas chamber may comprise a piston (sealed by an elastomeric sealing ring), or may comprise some sort of bellows arrangement, or any one of a number of other separator configurations, which are well known in the accumulator
30 art. However, most frequently, the separator comprises an elastomeric bladder comprising any one of a number of suitable bladder materials known in the art, such as nitrile rubber. Typically, the materials used for such bladders are permeable, or at least "semi-permeable", i.e., the material does, over a period of time, permit the nitrogen gas to pass through the bladder material, into the adjacent liquid chamber.

35 The above-described problem of gas permeation through the bladder is more likely to occur in a relatively high pressure accumulator, i.e., one in which the maximum pressure

of the liquid is in excess of 3000 or 4000 psi. or more, but such gas permeation also occurs, to a lesser extent, in low pressure accumulators. As is well known in the accumulator art, the gas permeation rate is a function of, among other factors, the gas pressure. In such liquid-gas accumulators, any gas which permeates through the bladder will typically remain in solution within the pressurized liquid. However, at some point, the high pressure liquid containing the nitrogen gas will flow to a relatively low pressure portion of the hydraulic circuit, at which point the nitrogen gas will be able (because of the lower pressure on the liquid) to form gas bubbles within the circuit. As is well known to those skilled in the hydraulic art, the presence of air or gas bubbles within a hydraulic circuit can result in noisy operation of various hydraulic components, and can cause damage to exposed surfaces of various hydraulic components (through a process known as "cavitation"), and eventually, reduced performance of, or failure of such components.

BRIEF SUMMARY OF THE INVENTION

Accordingly, it is an object of the present invention to provide an improved hydraulic accumulator of the liquid-gas type which is able to minimize the damage caused within its associated hydraulic circuit by gas bubbles, resulting from permeation of the pressurized gas through the permeable separator.

It is a more specific object of the present invention to provide an improved hydraulic accumulator which is able to achieve the above-stated object by collecting the gas which permeates through the separator, and communicating it to a location external to the accumulator.

The above and other objects of the invention are accomplished by the provision of an improved hydraulic accumulator of the liquid-gas type, comprising a rigid housing defining an internal chamber and a gas port and a liquid port. A gas charging valve is disposed in the gas port to control the admission of high pressure gas. A deformable, semi-permeable separator is disposed within the housing to separate the internal chamber into a gas chamber in communication with the gas port, and a liquid chamber in communication with the liquid port.

The improved hydraulic accumulator is characterized by means disposed within the liquid chamber for receiving and collecting gas which passes from the gas chamber through the semi-permeable separator into the liquid chamber. A conduit means has one end in fluid communication with the gas collecting means, and another end operably associated with the housing to communicate gas from the gas collecting means out of the liquid chamber.

In another aspect the invention provides a hydraulic accumulator of the liquid-gas type, comprising a rigid housing defining an internal chamber and a gas port and a liquid port; a gas charging valve disposed in said gas port to control the admission of high pressure gas; a deformable, semi-permeable separator disposed within said housing to separate said internal chamber into a gas chamber in communication with
5 said gas port, and a liquid chamber in communication with said liquid port; characterized by:

(a) means disposed within said liquid chamber for receiving and collecting gas which passes from said gas chamber, through said semi-permeable separator, into
10 said liquid chamber; and

(b) conduit means having one end in fluid communication with said gas collecting means, and another end operably associated with said housing to communicate gas from said gas collecting means (41) out of said liquid chamber;

characterised by said means for receiving and collecting gas comprising a
15 transfer membrane including a gas storage portion through which gas can travel when said transfer membrane is subjected to normal operating pressures in said liquid chamber; and said transfer membrane including a layer of material which is generally permeable to said gas in said gas chamber, while being generally impermeable to liquid, said layer of material being disposed between said gas chamber and said gas
20 storage portion of said transfer membrane.

Any discussion of documents, acts, materials, devices, articles or the like which has been included in the present specification is not to be taken as an admission that any or all of these matters form part of the prior art base or were common general knowledge in the field relevant to the present invention as it existed before the priority
25 date of each claim of this application.

Throughout this specification the word "comprise", or variations such as "comprises" or "comprising", will be understood to imply the inclusion of a stated element, integer or step, or group of elements, integers or steps, but not the exclusion of any other element, integer or step, or group of elements, integers or steps.

30

BRIEF DESCRIPTION OF THE DRAWINGS

FIG. 1 is a fragmentary, broken-away axial cross-section of a hydraulic accumulator utilizing the present invention.

FIG. 2 is an enlarged, fragmentary axial cross-section, similar to FIG. 1, illustrating
5 the gas collecting means of the present invention within the accumulator housing.

FIG. 3 is an enlarged, fragmentary view, taken in an upward direction in FIG. 2, but on a somewhat smaller scale than FIG. 2, illustrating the gas collection means of the present invention.

FIG. 4 is a fragmentary view, similar to FIG. 2, and on approximately the same
10 scale, but without showing the accumulator housing, showing in greater detail certain portions of the gas collecting means of the present invention.

FIG. 5 is a transverse cross-section through the gas collecting means of the present invention, taken on line 5-5 of FIG. 2.

15 DETAILED DESCRIPTION OF THE PREFERRED EMBODIMENT

Referring now to the drawings, which are not intended to limit the invention, FIG. 1 is a fragmentary, broken-away, axial cross-section of a typical hydraulic accumulator, modified to include the present invention. The accumulator includes a housing 11, defining an internal chamber 11C. The housing 11 may be of any suitable configuration,
20 such as spherical, but is shown herein as being cylindrical and horizontally elongated. By way of example only, an embodiment of an accumulator being developed by the assignee of the present invention includes a housing which is approximately ten inches in diameter, and approximately forty inches long. In one hydraulic system being developed by the assignee of the present invention, both a high pressure accumulator and a low pressure
25 accumulator are included in the system. In that particular system, and by way of example only, the present invention is included as part of the low pressure accumulator.

Disposed within an opening formed at the left end of the housing 11 is an oil port ring 13, and bolted to the ring 13 is a mounting flange member 15, by means of which the accumulator may, by way of example only, be bolted to a manifold block, or to some other
30 type of support structure. Disposed within the ring 13 and flange member 15 is a sleeve 17 which defines a fluid passage (also referred to hereinafter as a "liquid port") 19, providing fluid communication between the external hydraulic circuit (not shown) and a fluid (liquid) chamber 21 disposed within the housing 11.

The sleeve 17 supports, for reciprocable movement therein, a valve element 23
35 which, as is well known to those skilled in the accumulator art, is biased by a spring 25 toward the open position of the valve element 23, as shown in FIG. 1. It should be

understood by those skilled in the art that the present invention is not limited to any particular type or configuration of fluid port and valve arrangement. All that is essential to the present invention is that the accumulator include some suitable arrangement for communicating pressurized fluid between the external hydraulic circuit and the fluid chamber 21.

Referring still primarily to FIG. 1, disposed within a right-hand, open end of the housing 11 is a gas port ring 27 (which is at times hereinafter considered, and referred to, as part of the "housing"), and bolted to the gas port ring 27 is a cap member 29. The cap member 29 defines a gas port 30, and disposed within the gas port 30 is a gas charging valve assembly 31, by means of which pressurized gas may be communicated from an external source of pressurized gas into a gas chamber 33 disposed within a bladder 35, in a manner generally well known to those skilled in the art. Typically, and by way of example only, the bladder 35 is molded, or formed by some other suitable means, such that, in the presence of pressurized gas within the gas chamber 33 (and in the absence of substantial hydraulic pressure in the fluid chamber 21), the overall configuration of the bladder 35 will conform generally to that of the housing 11, as it is represented in FIG. 1. As is shown only in FIG. 1, the bladder 35 includes, at its rightward end, an enlarged bead 37 which is retained between the gas port ring 27 and the cap member 29.

The accumulator is illustrated in FIG. 1 as being horizontally oriented, with the fluid valve element 23 being disposed at one axial end thereof, and the gas charging valve assembly 31 being disposed at the other axial end thereof. However, those skilled in the art will understand that, if the accumulator were to be oriented vertically, rather than as shown in FIG. 1, there would be provided an annular (rather than elongated) version of the gas collector of the present invention, and it would be disposed under the gas port ring 27. Therefore, although the present invention would probably be most effective with the accumulator in the horizontal position shown in FIG. 1, it should be clear that neither configuration nor orientation comprise essential features of the invention.

Referring now to FIG. 2, in conjunction with FIG. 1, it may be seen that there is preferably a liner 39 (shown also in FIG. 5) disposed against the interior surface of the housing 11, for reasons which are now generally well understood in the accumulator art, and which bear no relationship to the present invention. By way of example only, the preferred embodiment of the present invention includes the liner 39 because the housing 11 comprises a filament wound (or fiber-reinforced) polymeric housing which, in the absence of the liner 39, could be sufficiently porous to permit the flow therethrough of a small amount of the hydraulic fluid contained in the fluid chamber 21.

Referring still primarily to FIG. 2, the present invention provides a gas collecting assembly, generally designated 41, a portion of which may also be referred to hereinafter as a "transfer membrane", for reasons which will become apparent to those skilled in the art from a reading and understanding of the rest of the specification. Preferably, with the accumulator having its axis of elongation oriented horizontally, the gas collecting assembly 41 would be disposed at or near the "top" of the internal chamber (fluid chamber 21) defined by the housing 11, as is shown in FIGS. 1, 2 and 5. It is preferable, for reasons which will become apparent subsequently, for the gas collecting assembly 41 to extend over a major portion of the entire axial extent of the accumulator, although it should be understood that such is not essential to the invention, except as is specifically otherwise noted in the claims. For example, in the subject embodiment, with the overall accumulator length being about forty inches, as was mentioned previously, the axial length of the gas collecting assembly 41 is about thirty inches.

Referring now primarily to FIGS. 2 through 5, the gas collecting assembly 41 will be described in greater detail. The gas collecting assembly 41 includes an internal layer of transfer fabric 43 which would preferably comprise an open-weave fabric, or felt, or open-cell foam, or any other suitable fabric or foam-type material which would not be readily degraded by the particular type of gas being used as the charging gas in the gas chamber 33 of the accumulator. However, the transfer fabric 43 must still allow the passage of the gas (nitrogen or other type of gas) through the body of the fabric. The primary function of the transfer fabric 43 is to allow movement of the nitrogen gas which has penetrated to the inside of the gas collecting assembly 41. The gas collected within the assembly 41 is the gas which has permeated through the bladder 35, and has risen through the fluid contained within the fluid chamber 21. By way of example only, the layer of transfer fabric 43 comprises, over most of the axial length of the assembly 41, a true "layer", approximately as shown in the left-hand portion of FIG. 4.

The gas collecting assembly 41 further includes an external barrier layer of semi-permeable material 41a (not shown in FIG. 4, see FIG. 5), which would preferably comprise a polymeric material (such as a silicone rubber), and which will allow the passage (permeation) of gas molecules, but will inhibit the passage of the larger hydraulic fluid molecules. Therefore, as gas rises within the fluid chamber 21, the gas will readily pass through the barrier layer 41a, and into the transfer fabric 43.

At the right end, in FIGS. 2 through 4, of the transfer fabric 43 is a tube member 45, which has one end 45a (its left in FIGS. 2 and 4) attached, by any suitable means, such as an adhesive connection 47, to the gas collecting assembly 41. As may best be seen in FIG. 2, while the left end 45a of the tube 45 is connected to the transfer fabric 43 of the

assembly 41, there is a right end 45b of the tube member 45, and the right end 45b is received within an angled bore formed in the gas port ring 27, such that the right end 45b of the tube member 45 is in open communication with a gas vent passage 49. The gas molecules, which are collected within the transfer fabric 43, are free to migrate through the fabric, and eventually work their way to and through the tube member 45, and out through the vent passage 49. Thus, the transfer fabric 43 and the barrier layer 41a together comprise the gas collecting assembly 41, which is also referred to hereinafter in the appended claims as a "means for receiving and collecting gas". The tubular member 45 is also referred to hereinafter in the appended claims as a "conduit means to communicate gas". It may be seen by comparing FIGS. 4 and 5 that the layer of transfer fabric 43 is not uniform over its entire axial length. As noted previously, the left-hand portion (in FIG. 4) of the transfer fabric 43 is a true layer, but in the region of the left end 45a of the tube member 45, the transfer fabric 43 includes an enlarged "transition" region which, in the subject embodiment, appears generally wedge-shaped surrounding the left end 45a.

Preferably, and as may best be seen in FIGS. 3 and 5, on the underside of the gas collecting assembly 41 is a structural layer 51. In the subject embodiment, but by way of example only, the structural layer 51 acts as a shield to protect the relatively fragile surface of the gas collecting assembly 41. More specifically, the purpose of the structural layer 51 is to protect the assembly 41 from engagement with the bladder 35, as it moves, while it is expanding or contracting. In the subject embodiment, and by way of example only, the structural layer 51 comprises a relatively stiff plastic member defining a series of holes 53, by means of which hydraulic fluid and gas can pass through the layer 51, and the gas can permeate the assembly 41, as described previously. Alternatively, the structural layer 51 could comprise a fabric member, or a perforated metal member, and it should be understood that the particular details of the layer 51 are not essential features of the invention. As may best be seen in FIG. 5, the opposite edges of the layer 51 are preferably attached (such as by a suitable adhesive) to the surface of the liner 39, thus "enclosing" the gas collecting assembly 41.

Those skilled in the art will understand that the gas vent passage 49 may be connected either to the atmosphere, in situations where it is acceptable for the particular charging gas to be vented to the atmosphere, or to some sort of gas collection arrangement, which would typically be disposed external to the accumulator, and which is beyond the scope of the present invention. What is important to note is that the tube member 45 is shown by way of example only, and all that is essential to the present invention is that there be provided some sort of "conduit means", which simply means some arrangement or

structure or whatever by means of which the trapped gas can pass from the transfer fabric 43 to another location.

Alternatively, the gas collecting assembly 41 may comprise a single layer of a semi-permeable material bonded to the liner 39, and bridging a gap, or a series of gaps, in the
5 liner 39. Therefore, in this embodiment, gas which has passed from the liquid in the fluid chamber 21 through the semi-permeable material may then continue through the gaps in the liner 39, and then penetrate (permeate) the porous molecular structure of the composite windings of the housing 11. Eventually, this gas will emerge from the housing 11 as free molecular gas, and pass into the environment. It is believed to be within the ability of those
10 skilled in the art to select the number and size of the openings or gaps in the liner 39 so as not to create significant resistance to the movement of gas molecules through the liner 39. In accordance with this alternative embodiment, the tube member 45 and the gas vent passage 49 are not required elements of the invention, and instead, the porous passages through the housing 11 comprise the "conduit means" of the appended claims.

As a further alternative embodiment, the gas collecting assembly may comprise a
15 single component, in the form of a semi-permeable material being used as the material for the liner 39, at least over some portion of the "top" inside surface of the housing 11, i.e., the portion wherein the assembly 41 of the main embodiment resides. For example, in this embodiment, the liner 39 (or a local portion thereof) could comprise the same material as
20 would be used for the semi-permeable material 41a in the primary embodiment. In accordance with this alternative embodiment, the tube member 45 and the gas vent passage 49 are again not required elements of the invention, and instead, that portion of the liner comprises the "means for receiving and collecting gas" for purposes of the appended claims, and the porous passages through the liner 39 and through the housing 11 comprise
25 the "conduit means" of the appended claims.

Although the present invention has been illustrated and described in connection with an embodiment in which the gas chamber 33 is surrounded by the liquid chamber 21, it should be understood that the present invention is not so limited. Instead, the bladder 35
30 could contain the liquid, and be surrounded by the gas chamber, in which case, the gas collecting assembly 41 would be disposed within the bladder 35 (and probably disposed toward the "top" thereof), and surrounded by the hydraulic fluid. In this embodiment, which is within the scope of the appended claims, unless otherwise specifically noted, the gas which permeates the bladder 35 would pass through the hydraulic fluid and be received by and collected within the assembly 41, and then communicated to the exterior of the
35 accumulator, as described previously.

The invention has been described in great detail in the foregoing specification, and it is believed that various alterations and modifications of the invention will become apparent to those skilled in the art from a reading and understanding of the specification. It is intended that all such alterations and modifications are included in the invention, insofar
5 as they come within the scope of the appended claims.

THE CLAIMS DEFINING THE INVENTION ARE AS FOLLOWS:

1. A hydraulic accumulator of the liquid-gas type, comprising a rigid housing defining an internal chamber and a gas port and a liquid port; a gas charging valve disposed in said gas port to control the admission of high pressure gas; a deformable, semi-permeable separator disposed within said housing to separate said internal chamber into a gas chamber in communication with said gas port, and a liquid chamber in communication with said liquid port; comprising:
- 5
- (a) means disposed within said liquid chamber for receiving and collecting gas which passes from said gas chamber, through said semi-permeable separator, into said liquid chamber; and
- 10
- (b) conduit means having one end in fluid communication with said gas collecting means, and another end operably associated with said housing to communicate gas from said gas collecting means out of said liquid chamber;
- 15
- characterized by said means for receiving and collecting gas comprising a transfer membrane including a gas storage portion through which gas can travel when said transfer membrane is subjected to normal operating pressures in said liquid chamber; and said transfer membrane including a layer of material which is generally permeable to said gas in said gas chamber, while being generally impermeable to liquid, said layer of material being disposed between said gas chamber and said gas storage portion of said transfer membrane.
- 20
2. A hydraulic accumulator as claimed in claim 1, characterized by said rigid housing is generally cylindrical and horizontally elongated, said gas port being disposed at one axial end of said housing, and said liquid port being disposed at the other axial end of said housing.
- 25
3. A hydraulic accumulator as claimed in claim 2, characterized by said semi-permeable separator comprising an elongated, generally cylindrical, elastically-deformable bladder defining therein said gas chamber, and having one end thereof fixed relative to said rigid housing adjacent said gas charging valve.
- 30
4. A hydraulic accumulator as claimed in claim 3, characterized by said generally cylindrical bladder being generally centrally disposed within said internal chamber defined by said rigid housing; said bladder being surrounded by said liquid chamber under most operating conditions of said accumulator.
- 35

5. A hydraulic accumulator as claimed in claim 4, characterized by said gas collecting means being elongated, and extending axially over at least a major portion of the axial length of said internal chamber, and being disposed above said bladder when said accumulator is in its operational position.

5

6. A hydraulic accumulator of the liquid-gas type, comprising a rigid housing defining an internal chamber and a gas port, and a liquid port; a gas charging valve disposed in said gas port to control the admission of high pressure gas; a deformable, semi-permeable separator disposed within said housing to separate said internal chamber into a gas chamber in communication with said gas port, and a liquid chamber in communication with said liquid port; characterized by:

10

(a) means disposed within said liquid chamber for receiving and collecting gas which passes from said gas chamber, through said semi-permeable separator, into said liquid chamber, said means comprising said rigid housing having disposed therein a line, including at least a portion of which is semi-permeable with respect to said gas; and

15

(b) conduit means having one end in fluid communication with said gas collecting means, and another portion operably associated with said housing to communicate gas from said gas collecting means, said conduit means comprising said rigid housing being formed from a porous filament material which is semi-permeable with respect to said gas.

20

7. A hydraulic accumulator as claimed in claim 6, characterized by said liner comprising a material which is substantially impermeable with respect to said liquid, but generally permeable with respect to said gas.

25

8. An accumulator according to any one of claims 1 to 8, substantially as hereinbefore described with reference to the figures.

30

35

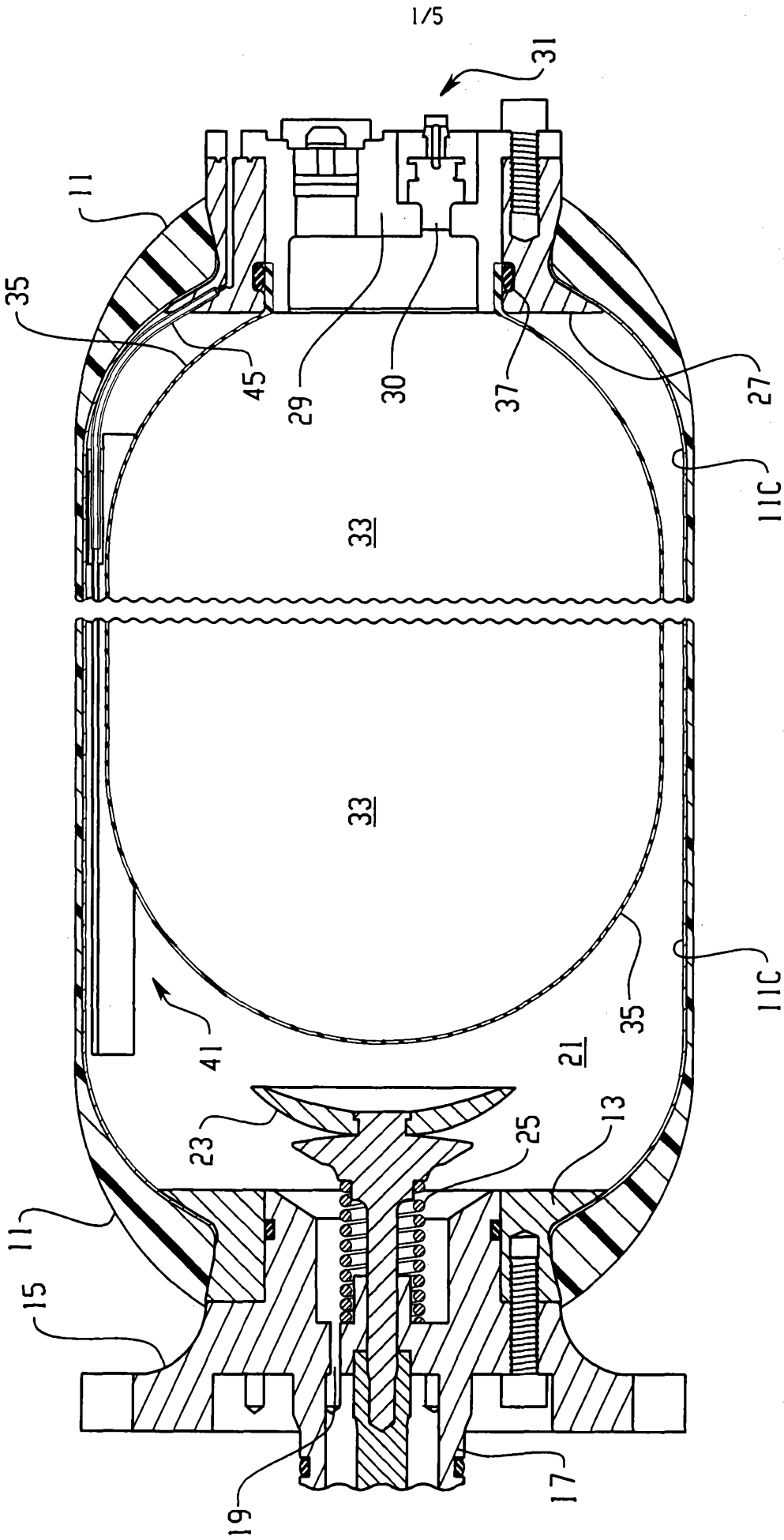

Fig. 1

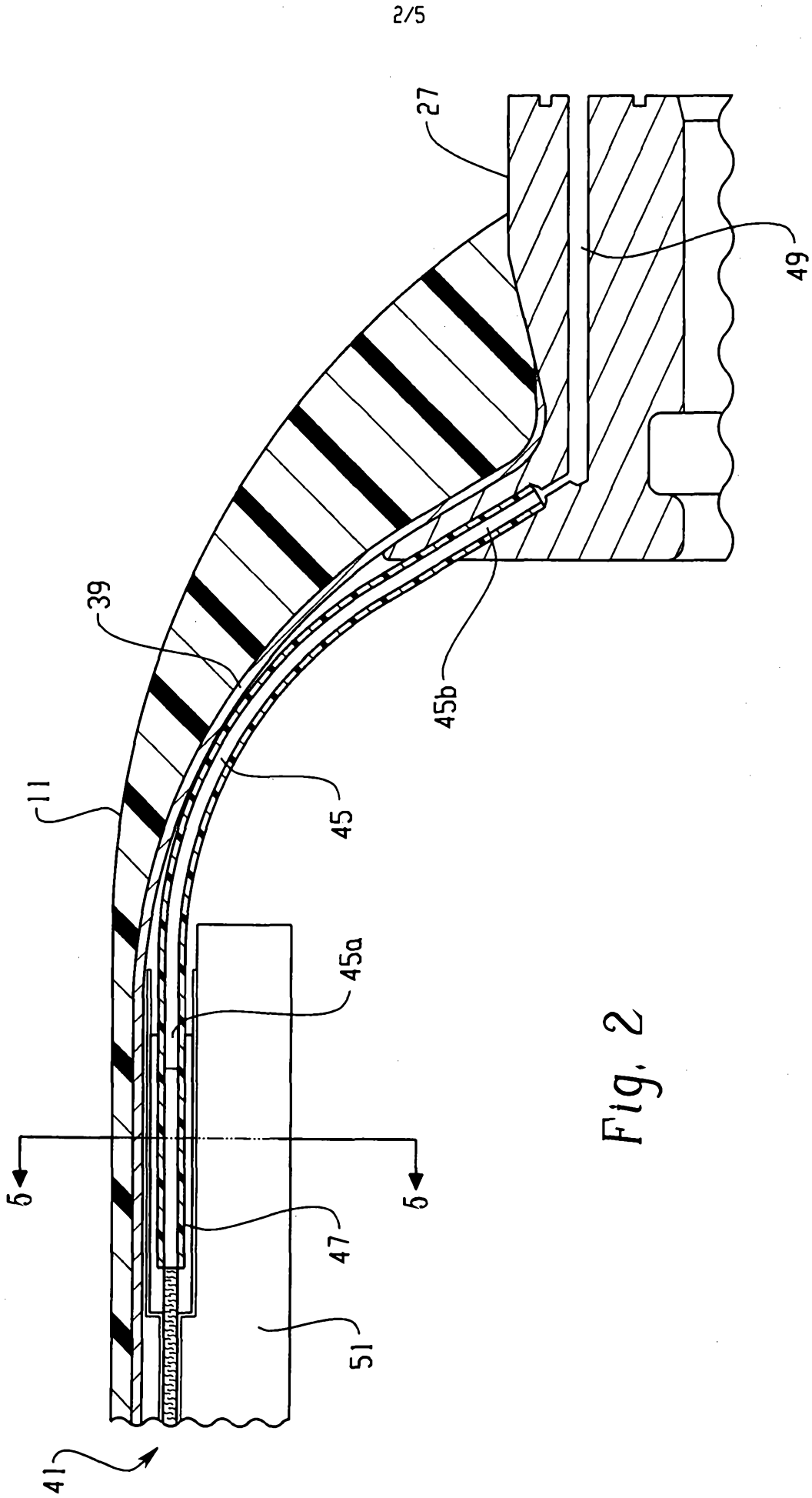

Fig. 2

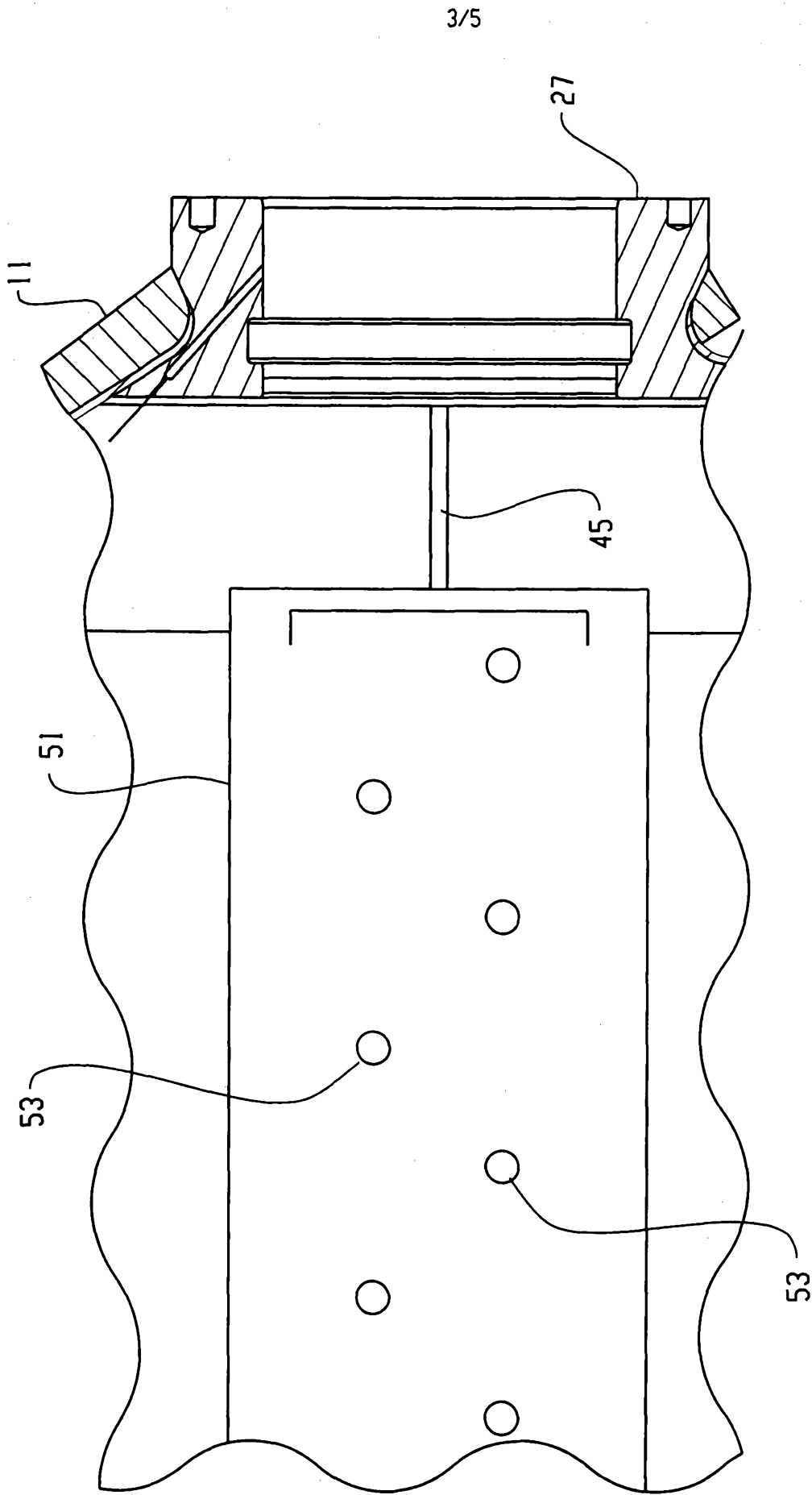

Fig. 3

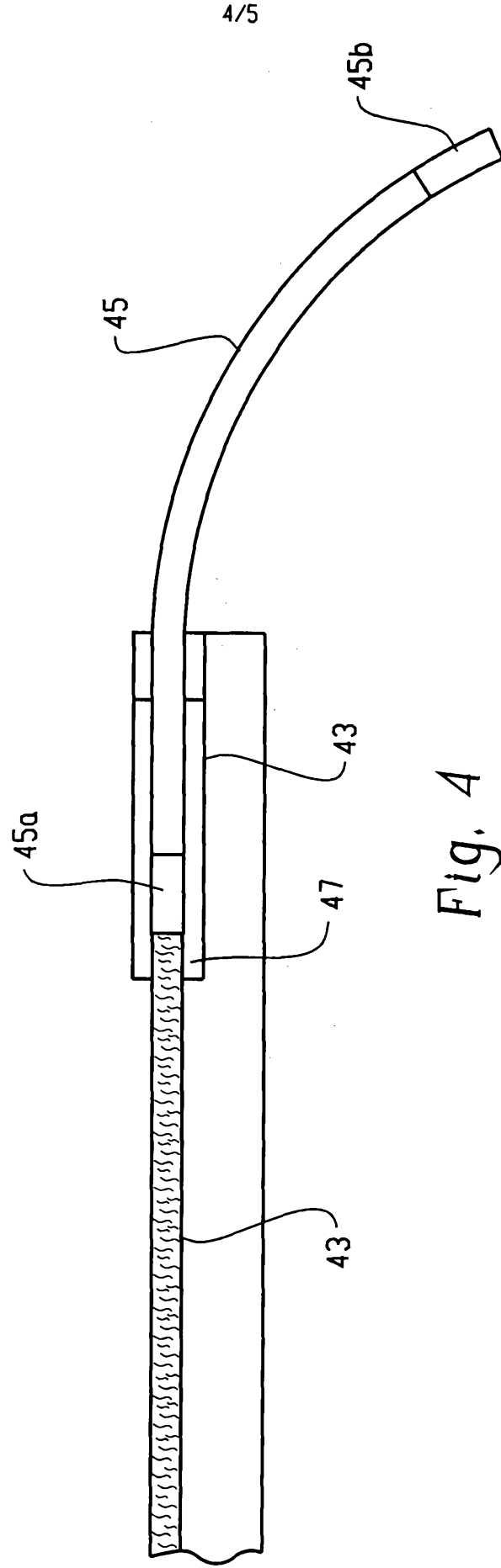

Fig. 4

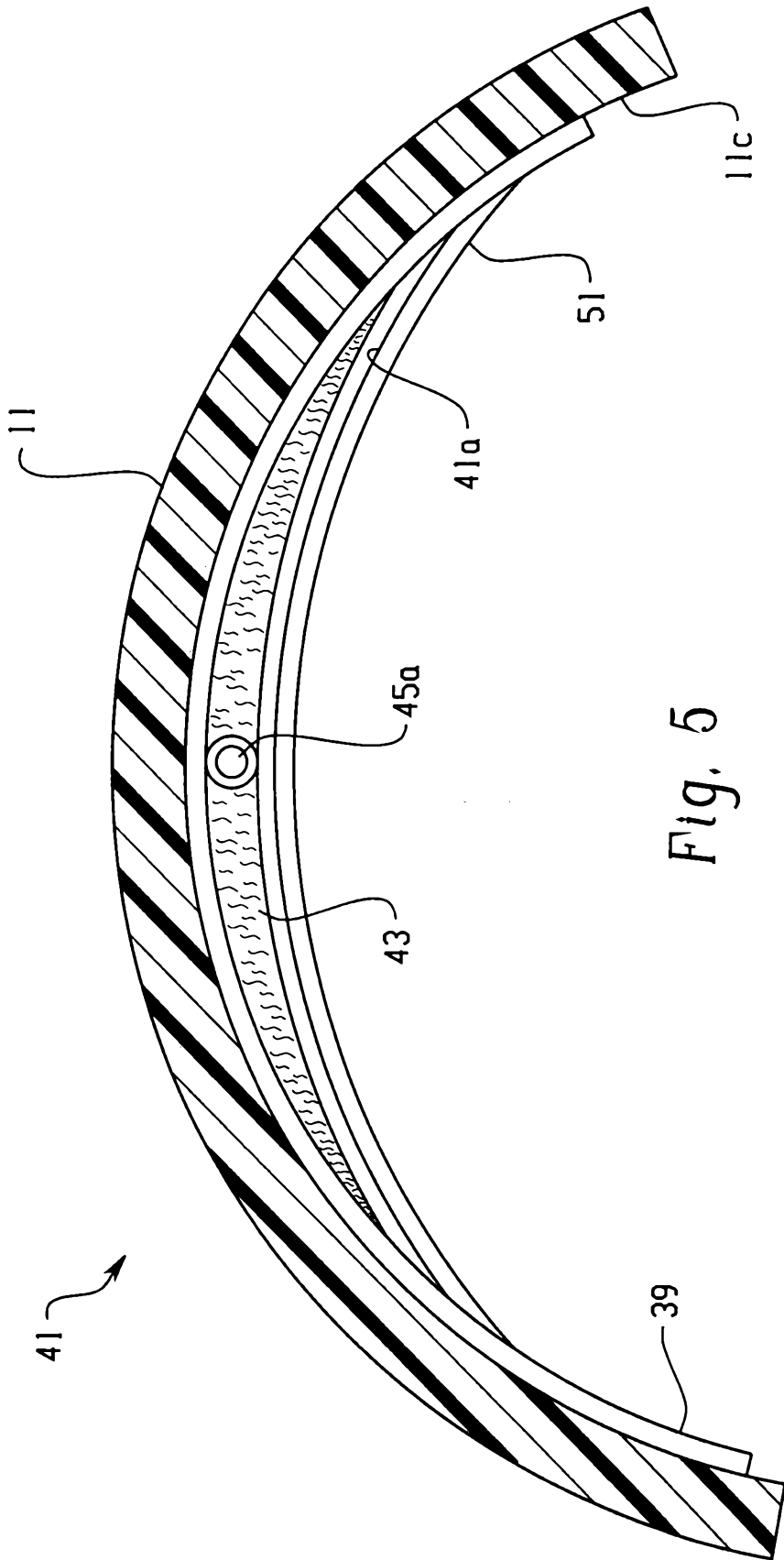

Fig. 5