

J. A. SMITH.
Bag-Holder.

No. 214,721.

Patented April 22, 1879.

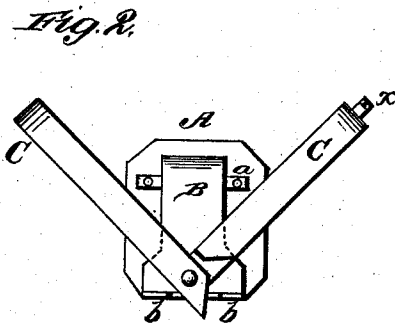
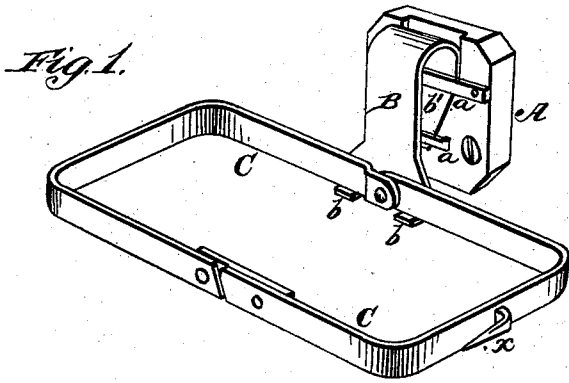

WITNESSES
Robert Crockett
H. Clay Smith

INVENTOR
James A. Smith
BY *Gilmore Smith & Co.*
ATTORNEYS.

UNITED STATES PATENT OFFICE.

JAMES A. SMITH, OF ASHLAND, OHIO.

IMPROVEMENT IN BAG-HOLDERS.

Specification forming part of Letters Patent No. 214,721, dated April 22, 1879; application filed February 8, 1879.

To all whom it may concern:

Be it known that I, JAMES A. SMITH, of Ashland, in the county of Ashland and State of Ohio, have invented certain new and useful Improvements in Bag-Holders; and I do hereby declare that the following is a full, clear, and exact description of the invention, which will enable others skilled in the art to which it appertains to make and use the same, reference being had to the accompanying drawings, and to letters of reference marked thereon, which form a part of this specification.

My invention relates to a portable bag-holder; and the novelty consists in the construction and arrangement of parts, as will be more fully hereinafter set forth.

The object of this invention is to provide a portable bag-holder, adapted to be applied to any desired place by suitable staples, and adapted to receive and hold a bag, the attachment and removal being easily and readily accomplished, as will be more fully set forth.

In carrying out my invention, I employ proper staples or sockets either upon a block adapted to be applied to a suitable beam, or the like, or directly upon the beam, which receives a hook upon a shank having lugs, studs, or stops, as shown.

Pivoted in the center of this shank are two bent or curved arms, which, when in a horizontal position, rest upon the said lugs. These arms partially close in an upward direction, and when so closed turn in either direction upon the pivotal point.

In using the device as a bag-holder, the jaws are raised until the mouth of the bag will pass over the same, when, by depressing the same until the arms bind properly within the bag, the same is held firmly and properly, for the purposes set forth.

In coffee-sacks, or larger bags, I employ a hook upon one of the arms, which takes up the slack of the bag by twice doubling the same and pulling it upon the hook in that condition. The bag is then treated as in the manner explained.

In the accompanying drawings, which form a part of this specification, Figure 1 is a perspective view, and Fig. 2 a front elevation, of my invention.

Referring to the drawings, A represents a portable block, having staples or sockets *a*, as shown, adapted to be secured by screws to any convenient place.

B designates a vertical shank, having stops *b*, the continuation of which shank forms a hook, *b'*, which operates in staples *a*. Pivoted to the shank B at the center are two bent arms, C C, which partially close in an upward direction, but cannot fall lower than a horizontal line, being stopped by the lugs *b*. Upon the outer edge of one of the arms is a hook, *x*, as shown, for the purpose set forth.

From the foregoing description the operation of my invention is obvious.

I am aware that pivoted jaws held in position by spring-catches, and adapted to enter the mouth of a grain-bag for distending and holding it, are not, broadly, new, as such a construction is shown in Patent No. 52,288, of January 30, 1866; and that a shelf and pins secured to a bracket have been used in connection with pivoted hook for a similar purpose, as seen in Patent No. 206,137, of July 16, 1878. These constructions I do not therefore claim.

Having thus described my invention, what I claim, and desire to secure by Letters Patent, is—

In a bag-holder, the combination, with the shank B, having the hook *b'* at its upper end and the lugs *b b* at its lower end, of the jaws or arms C C, pivoted to the shank B, and having the joints described, which permit said arms to partially close in an upward direction and to be opened downwardly until stopped by the lugs *b b*, whereby the mouth of the bag may be passed over the jaws, and the weight of the filling bag be made to serve in distending the mouth of the bag and gripping it for filling purposes, as set forth.

In testimony that I claim the foregoing as my own I affix my signature in presence of two witnesses.

JAMES ALBERT SMITH.

Witnesses:

J. D. JONES,
S. R. JONES.