

*J Hainsworth  
Steam Blower*

*No 75011*

*Patented March 3, 1868*

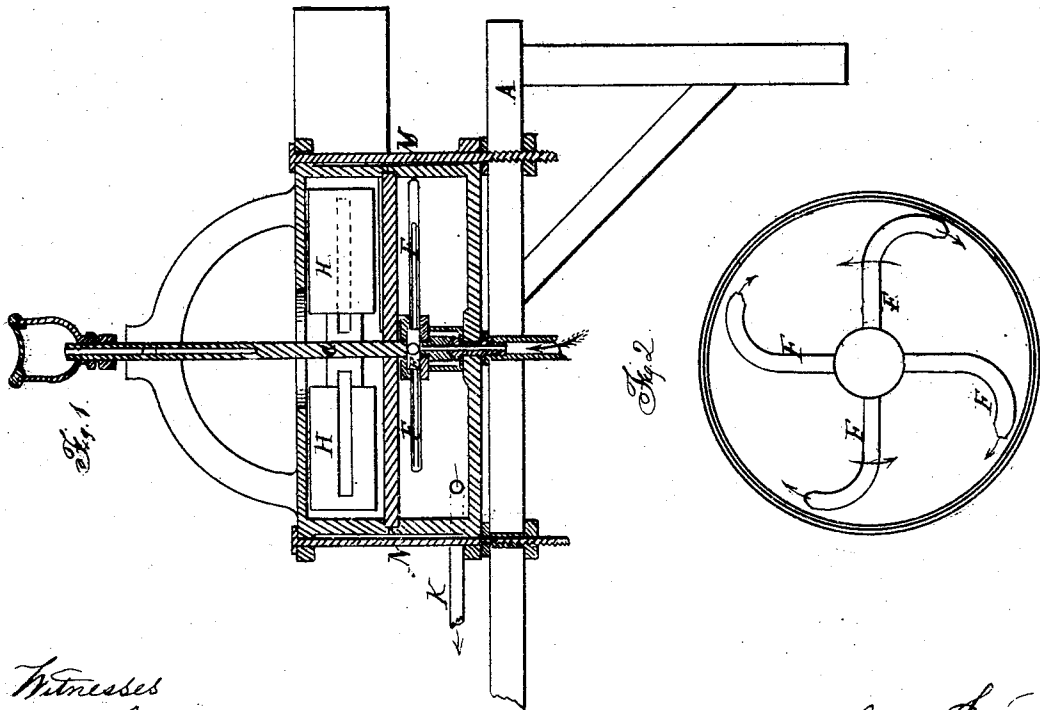
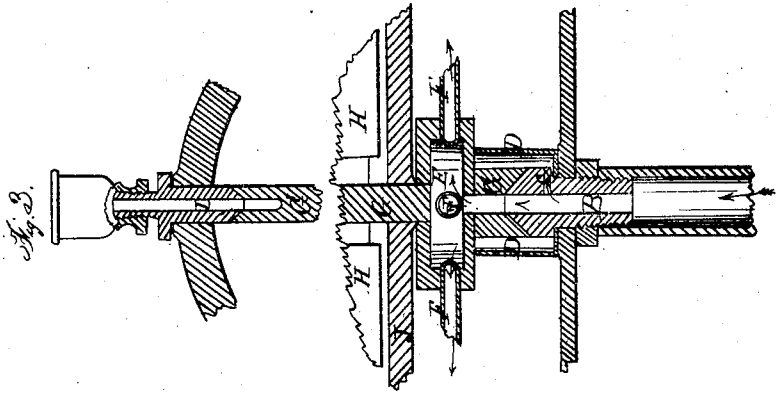

*Witnesses*  
*Franklin H. Brown* *Jonathan Hainsworth*  
*Charles Smith* *Inventor*

# United States Patent Office.

JONATHAN HAINSWORTH, OF CHICAGO, ILLINOIS.

Letters Patent No. 75,011, dated March 3, 1868; antedated February 24, 1868.

## IMPROVEMENT IN STEAM-BLOWERS.

The Schedule referred to in these Letters Patent and making part of the same.

### TO ALL WHOM IT MAY CONCERN:

Be it known that I, JONATHAN HAINSWORTH, of the city of Chicago, Cook county, and State of Illinois, have invented a new and improved Steam Fan-Blower; and I do hereby declare that the following is a full and exact description thereof, reference being had to the accompanying drawings, and to the letters of reference marked thereon, which form a part of this specification, in which—

Figure 1 represents a vertical central section of my steam-blower.

Figure 2 represents a bottom view of the revolving exhaust-pipes, which are attached to a hollow hub.

Figure 3 is an enlarged vertical central section of a portion of my steam-blower, showing more clearly its various parts.

The nature of my invention consists in the arrangement of the fans and steam-exhaust pipes with hubs upon a vertical shaft, in order that their weight may be supported by the pressure of steam, as hereinafter described; also, by means of an open chamber in the hub connecting with all of the exhaust-pipes and rigidly attached to the vertical shaft, which is supported and revolves between two stationary centres, whereby to supply steam to the exhaust-pipe with an even and unvarying pressure; also, a novel mode of lubricating the centres.

To enable those skilled in the art to make and use my invention, I will describe its construction and operation in detail.

A is a table or bench, to which I firmly attach my steam fan-blower by means of bolts and nuts, as shown in fig. 1. Said bolts and nuts are also made to hold the two casings of the blower together. B is the bottom centre. It has a central opening throughout its centre length for the passage of steam. D is a cup surrounding the lower end of shaft G, and held in position by a shoulder on centre B. C is a duct from the steam-passage in B to the cup D. H H are fan-blowers attached to a hub on shaft G. J is a partition separating the fan-blowers from the steam-exhaust pipes F. I is the upper centre, made hollow, for the purpose of lubricating the upper end of shaft G, as shown in figs. 1 and 3. E is a steam-chamber connecting with each and all of the pipes F at the same time, thus supplying to them an uninterrupted pressure of steam, causing the revolutions to be performed with unparalleled exactness. I place the shaft G in a vertical position, in order that its whole weight and the weight of the parts attached to it may be lifted and supported by the pressure of steam while in operation, which will almost entirely prevent friction, which cannot be accomplished in any other way than placing the machine, as shown, in a vertical position. The steam that passes through the duct C enters the cup D, and, condensing, acts as a lubricator to lower centre, B. K is the final exhaust-pipe, which may be carried to the outside of the building, as is usual with common steam-exhaust pipes.

Having thus fully described my invention, what I claim as new, and desire to secure by Letters Patent of the United States, is—

1. The arrangement of the vertical shaft G and steam-cup D, as and for the purposes set forth.
2. The arrangement of the vertical hollow centre I and shaft G, as and for the purposes specified.
3. The combination of the cup D, steam-duct C, and centre, B, as and for the purposes set forth.

JONATHAN HAINSWORTH.

Witnesses:

JNO. W. SHERWOOD,  
CHAS. C. SMITH.