

April 16, 1940.

B. R. MCKINLEY

2,197,078

FORMATION TESTER

Filed Oct. 25, 1937

2 Sheets-Sheet 1

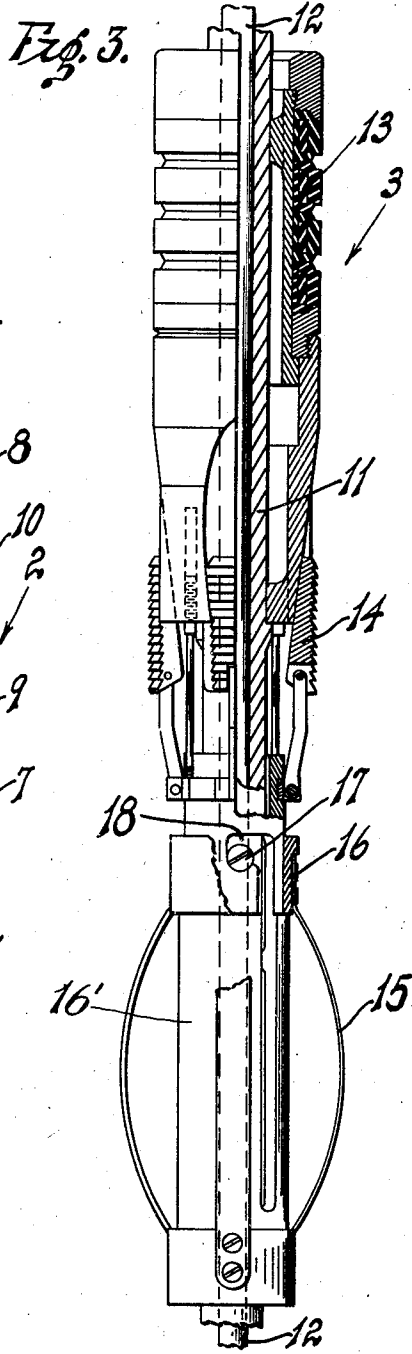
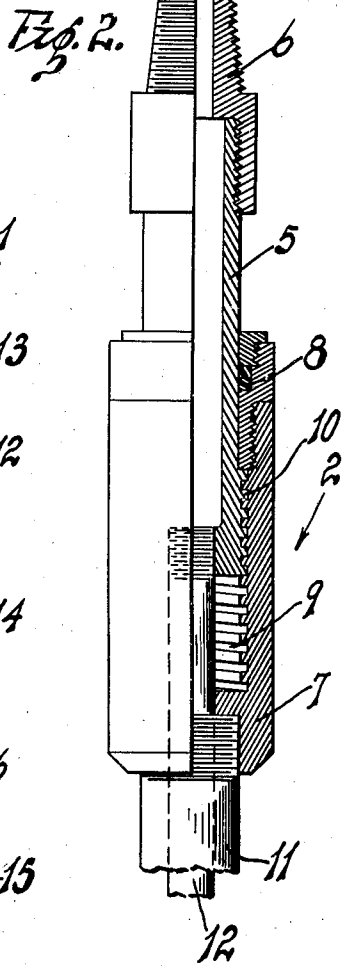
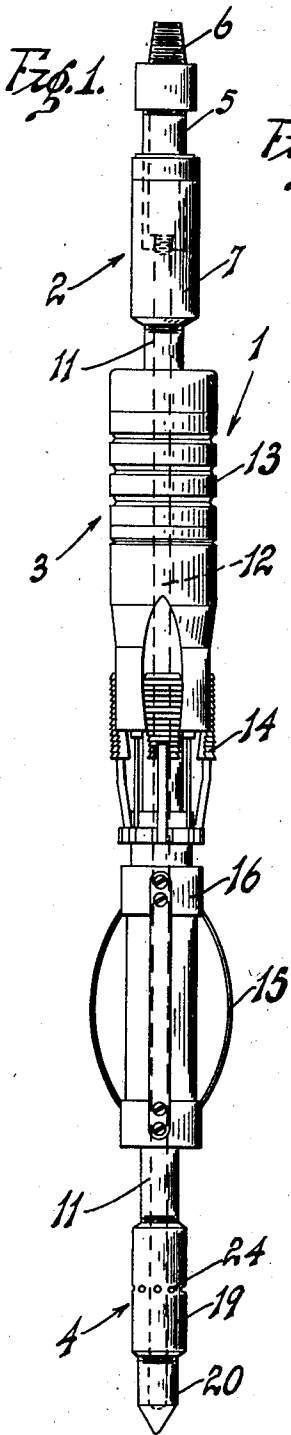

INVENTOR.
BOYD R. MCKINLEY.
BY *H. C. Duckman*
ATTORNEY.

April 16, 1940.

B. R. McKINLEY

2,197,078

FORMATION TESTER

Filed Oct. 25, 1937

2 Sheets-Sheet 2

Fig. 4.

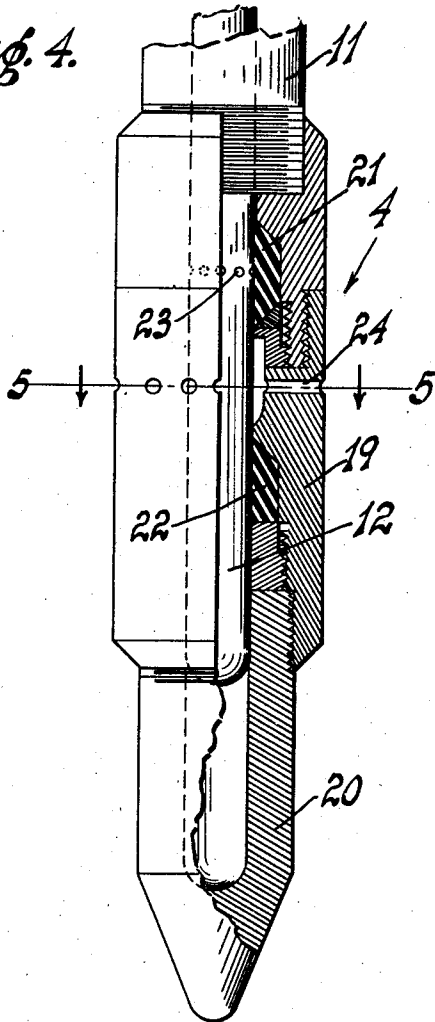

Fig. 6.

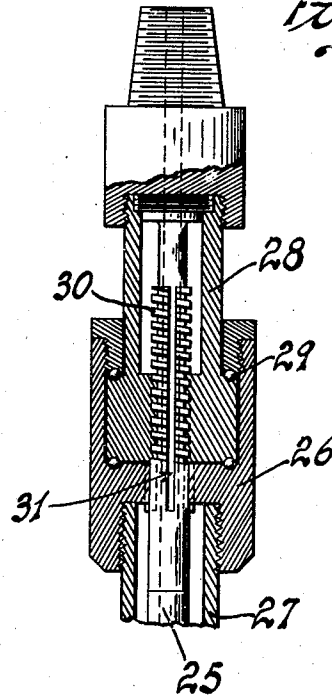
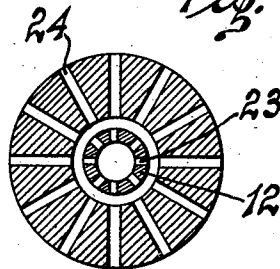

Fig. 5.



INVENTOR.
BOYD R. MCKINLEY.
BY
H. R. Duckman
ATTORNEY.

UNITED STATES PATENT OFFICE

2,197,078

FORMATION TESTER

Boyd R. McKinley, Los Angeles, Calif.

Application October 25, 1937, Serial No. 170,848

7 Claims. (Cl. 166—1)

This invention relates to a casing and formation tester, particularly applicable to oil and gas wells, for the purpose of determining the presence of oil or gas within the bore of the well.

5 An object of my invention is to provide a novel means to open and close the ports of the formation tester by rotation of the string of drill pipe in one direction.

10 Another object is to provide a novel construction in a formation tester whereby the ports of the tester are gradually opened, whereby cutting of the ports and orifice is prevented and also a more complete and representative sample of the production in the well is obtained.

15 Other objects, advantages and features of invention may appear from the accompanying drawings, the subjoined detailed description and the appended claims.

In the drawings:

20 Figure 1 is a side elevation of my casing and formation tester.

Figure 2 is a quarter sectional view of the upper portion of the tester.

25 Figure 3 is a quarter sectional view of the central portion of the tester.

Figure 4 is a quarter sectional view of the lower portion of the tester.

Figure 5 is a sectional view taken on line 5—5 of Figure 4.

30 Figure 6 is a fragmentary vertical sectional view of a slightly modified form of port actuating means.

35 Referring more particularly to the drawings, my casing and formation tester 1 comprising the assembly of a control head 2, a packer 3, and a ported intake sleeve 4. The sub 5 is provided with a threaded pin 6, on to which the drill pipe screws. The drill pipe is not shown, since its construction is usual and well known.

40 The sub 5 extends into the sleeve 7 through a packing gland 8. Coarse threads 9 are cut on the inside of the sleeve 7, and the sub 5 is provided with coarse exterior threads 10, which mesh with the threads 9. Thus, it will be evident that 45 if the sleeve 7 is held stationary, rotation of the sub 5 will cause this sub to move longitudinally within the sleeve. The sub 5 is hollow and the pin 6 is also centrally drilled, so that gas and oil can pass upwardly therethrough, for a purpose 50 which will be subsequently described.

55 A pipe section 11 screws into the lower end of the sleeve 7, or is otherwise fixedly attached thereto. This pipe extends longitudinally through the packer assembly and screws into the top of the ported shoe 4, as shown in Figure 4.

A simple tube 12 screws into the lower end of the sub 5, and extends downwardly through the pipe 11, and the lower end thereof is slidably fitted in the shoe 4, as will be further described. The sample tube 12 slides in the pipe 11, when 5 the control head 2 is operated.

The packer assembly 3 of the type shown in Patent #2,005,955 consists of a packer 13 and slips 14 slidably mounted below the packer or as here shown the slips are slidably mounted in the 10 lower metal part of the packer. These slips are adapted to engage either the casing or the formation, wherever the tester may be run. Spring fingers 15 engage the wall of the bore and these 15 fingers are mounted on collars 16, one of the collars being releasably attached to the pipe 11 by means of the pin 17, which enters the bayonet slot 18. The pin 17 is mounted on the pipe 11 and extends into the slot 18; a short sleeve 16' 20 connects the collars 16, and the collars may be attached to this sleeve or they may be integrally formed therewith. When the fingers 15 are dragging against the wall of the bore, rotation of the pipe 11 to the left will release the pin 17 25 from the slot 18. When the entire tester is lowered, the upper sleeve 16 will engage the slips 14, causing them to be pushed outwardly on their tapered seats to engage the wall of the bore. Thus the entire packer assembly is fixed 30 within the bore, and is non-rotatably held. The pipe 11 is also held against rotation since the pin 17 is held within the elongated slot 18.

35 Since the pipe 11 is held against rotation, the sleeve 7 is also held stationary and consequently rotation of the drill pipe will cause the sub 5 to be screwed into the sleeve 7, and causes the sub to move downwardly in the sleeve.

40 The sample tube 12 is thus pushed downwardly into the shoe 4. This shoe consists of an outer cylindrical body 19, below which the plug 20 extends. A pair of spaced packings 21—22 are 45 mounted within the body 19 and fit closely around the sample tube 12.

50 A plurality of ports 23 extend through the wall of the tube 12, and when the tool is run into the bore, these ports are closed by the packing 21, as shown in Figure 4. A plurality of intake holes 24 extend through the wall of the body 19, and these holes are positioned by the packing 55 21 and 22. When the sub 5 is rotated by the drill pipe as previously described, the sample tube 12 will be pushed downwardly into the shoe 4, until the ports 23 pass below the packing 21, whereupon oil, gas, or the like, within the bore, 55

will pass into the holes 24, thence through the ports 23 into the sampling tube 12.

Continued rotation of the drill pipe will cause the tube 12 to be pushed downwardly a further amount within the shoe 4 until the ports 23 are closed by the packing 22, and the sample within the tube 12 will be trapped and can be raised to the surface. The lower end of the tube 12 is closed so that any material within the tube cannot drain out of the bottom.

It will be evident from the foregoing description that the ports 23 can be gradually opened or closed and also in both open and closed position of these ports, an effective seal is provided against leakage by the packing 21 or 22. It will also be evident that rotation of the drill pipe in one direction will cause the ports 23 to move downwardly into position to receive a sample, and will then continue to move the ports downwardly until the sampling tube is again sealed with the material trapped therein.

In Figure 6 I have shown a slightly modified means of moving the sampling tube 25 longitudinally of the tool. A head 26 is attached to the upper end of a pipe 27. The pipe 27 is identical to the pipe 11 previously described, and the arrangement of the pipe, as well as the arrangement of the packer and the port shoe, are the same as previously described. The sub 28 extends into the head 26, and is mounted on anti-friction bearings 29. The upper end of the tube 25 is threaded as shown at 30, and this portion of the tube screws through the sub 28. Longitudinal key ways 31 in the upper end of the tube 25 key this tube to the head 26. The purpose of these key ways is to prevent rotation of the tube 25. This tube is held against rotation since the pipe 27 and head 26 are held against rotation by the packer and slip assembly previously described. Rotation of the drill pipe will cause the sub 28 to rotate, whereupon the tube 25 will be pressed downwardly due to the action of the threads 30.

The lower end of the tube 25 is arranged as shown in Figure 4.

Having described my invention, I claim:

1. A casing and formation tester for bored holes comprising a control head, a sub rotatably mounted in the control head, wall engaging means connected to the control head to non-rotatably hold said control head in the hole inter-engaging means on the sub and control head, whereby rotation of the sub relative to the control head will impart longitudinal movement to said sub, said co-acting means being constantly in engagement, a sampling tube depending from the sub, an intake shoe, said tube extending into the shoe and longitudinally slidable therein, said shoe having holes therein and said tube having ports therein, said ports being moved into and out of registry with the holes during longitudinal movement of the sub and sampling tube, and rotation of the sub in one direction.

2. A casing and formation tester for bored holes comprising a control head, a sub rotatably mounted in the control head, wall engaging means connected to the control head to non-rotatably hold said control head in the hole inter-engaging means on the sub and control head, whereby rotation of the sub relative to the control head will impart longitudinal movement to said sub, said co-acting means being constantly in engagement, a sampling tube depending from the sub, an intake shoe, said tube extending into the shoe and longitudinally slidable therein, said

shoe having holes therein and said tube having ports therein, said ports being moved into and out of registry with the holes on longitudinal movement of the sub and sampling tube and rotation of the sub in one direction, said intake shoe having packing therein, arranged above and below the holes in the shoe, said packing bearing against the sampling tube.

3. A casing and formation tester for bored holes comprising a control head, a sub rotatably mounted in the control head, wall engaging means connected to the control head to non-rotatably hold said control head in the hole, co-acting means on the sub and control head, whereby rotation of the sub relative to the control head will impart longitudinal movement to said sub, said co-acting means being constantly in engagement, a sampling tube depending from the sub, an intake shoe, said tube extending into the shoe and longitudinally slidable therein, said shoe having holes therein and said tube having ports therein, said ports being moved into and out of registry with the holes on longitudinal movement of the sub and sampling tube and rotation of the sub in one direction, means non-rotatably holding the control head when in position in the bored hole, said intake shoe having packing therein arranged above and below the holes in the shoe, said packing bearing against the sampling tube, and packer means depending from the control head.

4. A casing and formation tester for bored holes, comprising a control head, a sub rotatably mounted in the control head, wall engaging means connected to the control head to non-rotatably hold said control head in the hole, co-acting threads on the sub and control head, said threads being in constant engagement whereby rotation of the sub relative to the control head will impart longitudinal movement to said sub, a sampling tube depending from the sub, an intake shoe, said tube extending into the shoe, said shoe having holes therein and said tube having ports therein, said ports being moved into and out of registry with the holes on longitudinal movement of the sub, and the sampling tube, and rotation of the sub in one direction.

5. A casing and formation tester for bored holes comprising a control head, a sub rotatably mounted in the control head, wall engaging means connected to the control head to non-rotatably hold said control head in the hole, co-acting threads on the sub and control head, said threads being in constant engagement whereby rotation of the sub relative to the control head will impart longitudinal movement to said sub, a sampling tube depending from the sub, an intake shoe, said tube extending into the shoe, said shoe having holes therein and said tube having ports therein, said ports being moved into and out of registry with the holes on longitudinal movement of the sub and the sampling tube and rotation of the sub in one direction, and spaced packing within the intake shoe and surrounding the sampling tube, said packing being arranged above and below said holes.

6. A casing and formation tester for bored holes, comprising an intake shoe on the lower end of the tester, a packer, a control head on the upper end of the tester, a pipe attached to the control head and the intake shoe, said pipe extending through the packer, a sampling tube extending through the pipe and into the control head, said intake shoe having holes in the side thereof, said sampling tube having openings

therein arranged to be registered with said holes, said control head including a sub rotatably mounted therein, inter-engaging threads on the control head and sub whereby rotation of the sub will impart longitudinal movement to the sampling tube, said sampling tube being secured to the sub, said threads being in constant engagement, and wall engaging means connected to the control head whereby the control head is held against rotation in a bored hole.

7. A casing and formation tester for bored holes, comprising an intake shoe on the lower end of the tester, a packer, a control head on the upper end of the tester, a pipe attached to the control head and the intake shoe, said pipe extending through the packer, a sampling tube ex-

tending through the pipe and into the control head, said intake shoe having holes in the side thereof, said sampling tube having openings therein arranged to be registered with said holes, said control head including a sub rotatably mounted therein, inter-engaging means on the sub and control head whereby rotation of the sub will impart longitudinal movement to the sub and the sampling tube, said sampling tube being secured to the sub, said inter-engaging means being in constant engagement, and wall engaging means connected to the control head whereby the control head is held against rotation in a bored hole.

BOYD R. MCKINLEY. 15