

(19) World Intellectual Property Organization
International Bureau



(43) International Publication Date
11 June 2009 (11.06.2009)

PCT

(10) International Publication Number
WO 2009/073496 A2

- (51) **International Patent Classification:**
F24F 11/02 (2006.01) *F24F 1/00* (2006.01)
- (21) **International Application Number:**
PCT/US2008/084787
- (22) **International Filing Date:**
26 November 2008 (26.11.2008)
- (25) **Filing Language:** English
- (26) **Publication Language:** English
- (30) **Priority Data:**
60/991,626 30 November 2007 (30.11.2007) US
12/323,370 25 November 2008 (25.11.2008) US
12/323,303 25 November 2008 (25.11.2008) US
- (71) **Applicant (for all designated States except US):** HONEYWELL INTERNATIONAL INC. [US/US]; Law Department AB/2B, 101 Columbia Road, Morristown, NJ 07962 (US).
- (72) **Inventors; and**
- (75) **Inventors/Applicants (for US only):** AMUNDSON, John [US/US]; 3915 Harriet Avenue, Minneapolis, Minnesota

55409 (US). **BOLL, Jeffrey** [US/US]; 9148 Georgia Avenue North, Brooklyn Park, Minnesota 55445 (US). **ERICKSON, Peter** [US/US]; 8400 Golden Valley Road, Apt. 110, Golden Valley, Minnesota 55427 (US).

(74) **Agent:** BEATUS, Carrie; Honeywell International Inc., Law Department AB/2B, 101 Columbia Road, Morristown, New Jersey 07962 (US).

(81) **Designated States (unless otherwise indicated, for every kind of national protection available):** AE, AG, AL, AM, AO, AT, AU, AZ, BA, BB, BG, BH, BR, BW, BY, BZ, CA, CH, CN, CO, CR, CU, CZ, DE, DK, DM, DO, DZ, EC, EE, EG, ES, FI, GB, GD, GE, GH, GM, GT, HN, HR, HU, ID, IL, IN, IS, JP, KE, KG, KM, KN, KP, KR, KZ, LA, LC, LK, LR, LS, LT, LU, LY, MA, MD, ME, MG, MK, MN, MW, MX, MY, MZ, NA, NG, NI, NO, NZ, OM, PG, PH, PL, PT, RO, RS, RU, SC, SD, SE, SG, SK, SL, SM, ST, SV, SY, TJ, TM, TN, TR, TT, TZ, UA, UG, US, UZ, VC, VN, ZA, ZM, ZW.

(84) **Designated States (unless otherwise indicated, for every kind of regional protection available):** ARIPO (BW, GH,

[Continued on next page]

(54) **Title:** HVAC CONTROLLER

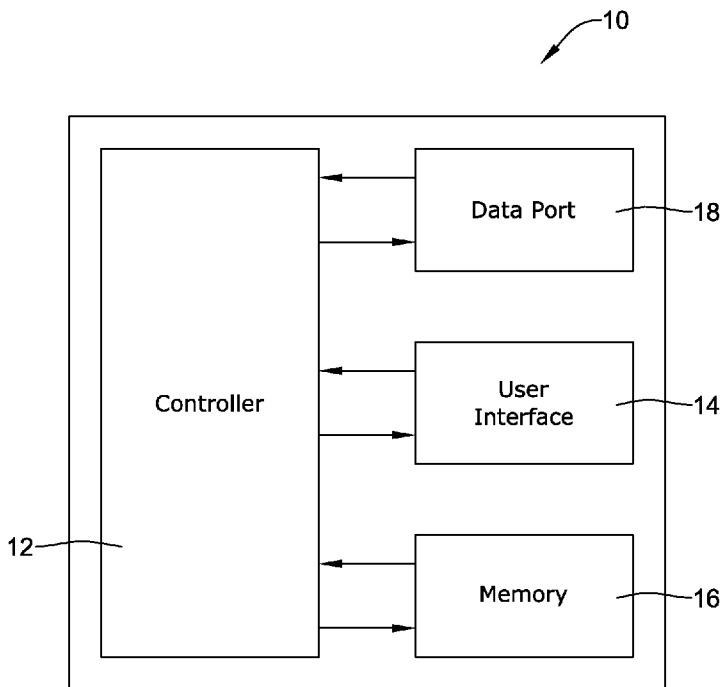

(57) **Abstract:** An HVAC controller (10; 20) is described that is configured to be more intuitive and user friendly to program and operate than convention HVAC controllers. In some instances, the HVAC controller (10; 20) may include a touch screen interface (14) that provides greater flexibility in displaying information to the user and/or soliciting information from the user.

Figure 1

WO 2009/073496 A2



GM, KE, LS, MW, MZ, NA, SD, SL, SZ, TZ, UG, ZM, ZW), Eurasian (AM, AZ, BY, KG, KZ, MD, RU, TJ, TM), European (AT, BE, BG, CH, CY, CZ, DE, DK, EE, ES, FI, FR, GB, GR, HR, HU, IE, IS, IT, LT, LU, LV, MC, MT, NL, NO, PL, PT, RO, SE, SI, SK, TR), OAPI (BF, BJ, CF, CG, CI, CM, GA, GN, GQ, GW, ML, MR, NE, SN, TD, TG).

Published:

— *without international search report and to be republished upon receipt of that report*

HVAC CONTROLLER

Related Applications

This application claims priority to U.S. Provisional Application serial number
5 60/991,626, entitled "HVAC CONTROLLER", the entirety of which is incorporated
herein by reference.

Technical Field

The disclosure relates generally to HVAC controllers.

Background

10 Heating, ventilation, and/or air conditioning (HVAC) systems are often used
to control the comfort level within a building or other structure. Many HVAC
controllers include a controller that activates and deactivates one or more HVAC
components of the HVAC system to affect and control one or more environmental
conditions within the building. These environmental conditions can include, but are
15 not limited to, temperature, humidity, and/or ventilation. In many cases, such HVAC
controller may include, or have access to, one or more sensors, and may use
parameters provided by the one or more sensors to control the one or more HVAC
components to achieve desired programmed or set environmental conditions.
Because of the increased complexity of such modern HVAC controllers,
20 programming and/or operating such devices can be considered difficult and/or
confusing, particularly for novice and/or non-technical users. Thus, there is a need for
HVAC controllers that are more intuitive and user friendly to program and operate.

Summary

This disclosure relates to HVAC controllers that are configured to be more
25 intuitive and user friendly to program and operate. In some instances, the disclosure
relates to HVAC controllers that include a touch screen interface that provides greater
flexibility in displaying relevant information to the user and/or soliciting information
from the user, although this is not required.

The above summary is not intended to describe each and every disclosed
30 embodiment or every implementation of the disclosure. The Description that follows
more particularly exemplifies the various illustrative embodiments.

Brief Description of the Figures

The following description should be read with reference to the drawings, in which like elements in different drawings are numbered in like fashion. The drawings, which are not necessarily to scale, depict selected embodiments and are not intended to limit the scope of the disclosure. The disclosure may be more completely understood in consideration of the following detailed description of various embodiments in connection with the accompanying drawings, in which:

- Figure 1 is a schematic view of an illustrative but non-limiting HVAC controller;
- Figure 2 is a front view of an illustrative but non-limiting HVAC controller;
- Figures 3 through 11 provide illustrative but non-limiting examples of home screens that may be displayed upon the HVAC controllers of Figures 1 and 2;
- Figures 12 through 17 provide illustrative but non-limiting examples of screens pertaining to changing and/or viewing humidification and dehumidification settings using the HVAC controllers of Figures 1 and 2; and
- Figures 18 through 21 provide illustrative but non-limiting examples of screens pertaining to changing and/or viewing preferences information using the HVAC controllers of Figures 1 and 2.

While the invention is amenable to various modifications and alternative forms, specifics thereof have been shown by way of example in the drawings and will be described in detail. It should be understood, however, that the intention is not to limit the invention to the particular embodiments described. On the contrary, the intention is to cover all modifications, equivalents, and alternatives falling within the spirit and scope of the invention.

Description

Generally, the disclosure pertains to simplified interfaces for controllers having programming capabilities. These controllers can be used in a variety of systems such as, for example, HVAC systems, water heater systems, water softener systems, sprinkler systems, security systems, lighting systems, and the like. The Figures depict HVAC controllers. While the present invention is not so limited, an appreciation of various aspects of the invention will be gained through a discussion of the examples provided below.

Figure 1 is a schematic view of an illustrative HVAC controller 10. In some cases, HVAC controller 10 may be considered to be a thermostat, but this is not

required. HVAC controller 10 includes a processor or controller 12 and a user interface 14. Controller 12 may be adapted to operate in accordance with an algorithm that controls or at least partially controls one or more components of an HVAC system. In some instances, the algorithm may include a number of operating parameters. Examples of components that may be controlled by controller 12 include one or more of a furnace, a boiler for hot water heat or steam heat, a heat pump, an air conditioning unit, a humidifier, a dehumidifier, an air exchanger, an air cleaner, and the like. Controller 12 may, for example, operate in accordance with an algorithm that provides temperature set points, starting and/or ending times, and the like.

User interface 14 may be any suitable interface that permits controller 12 to display and/or solicit information as well as permitting a user to enter data such as temperature set points, humidity set points, starting times, ending times, and the like. In some cases, user interface 14 may include a display and a distinct keypad. A display may be any suitable alphanumeric display. In some instances, a display may include or may be a liquid crystal display (LCD). If desired, user interface 14 may be a touch screen LCD panel that functions as both display and keypad. In some instances, a touch screen LCD panel may be adapted to solicit values for a number of operating parameters and/or to receive said values.

HVAC controller 10 may include a memory block 16 that may be considered as being electrically connected to controller 12. Memory block 16 may be used to store any desired information, such as the aforementioned control algorithm, set points, and the like. Controller 12 may store information within memory block 16 and may subsequently retrieve the stored information. Memory block 16 may be any suitable type of storage device, such as RAM, ROM, EPROM, a flash drive, a hard drive, and the like.

In some cases, as illustrated, HVAC controller 10 may include a data port 18. Data port 18 may be configured to communicate with controller 12 and may, if desired, be used to either upload information to controller 12 or to download information from controller 12. Information that can be uploaded or downloaded may include values of operating parameters. In some instances, data port 18 may be used to upload a previously-created thermostat configuration into HVAC controller 10, thereby hastening the programming process. In some cases, data port 18 may be used to download a thermostat configuration that has been created using HVAC controller 10, so that the thermostat configuration may be used in other thermostats. In some

cases, data port 18 may be used to upload and/or download information pertaining to an HVAC dealer or contractor.

Data port 18 may be a wireless port such as a Bluetooth™ port or any other wireless protocol. In some cases, data port 18 may be a wired port such as a serial port, a parallel port, a CAT5 port, a USB (universal serial bus) port, or the like. In some instances, data port 18 may be a USB port and may be used to download and/or upload information from a USB flash drive. Other storage devices may also be employed, as desired.

Figure 2 is a front view of an illustrative HVAC controller 20. In some cases, HVAC controller 20 may represent a manifestation of HVAC controller 10 (Figure 1), but this is not required. HVAC controller 20 includes a display 22 that is disposed within a housing 24. In some cases, display 22 may be a touch screen LCD display. If desired, display 22 may be a dot matrix touch screen LCD display. A dot matrix touch screen LCD display is a touch screen LCD that permits images such as letters, numbers, graphics, and the like to be displayed anywhere on the LCD, rather than being confined to predetermined locations such as is the case with a fixed segment LCD. Housing 24 may be formed of any suitable material, such as a polymeric material.

In some cases, HVAC controller 20 may be configured to provide substantial display and/or programming functionality. Figures 3 through 11 provide examples of home screens that may be displayed by HVAC controller 20. In some cases, home screens may include screens that can be accessed by a top level navigational menu. In some cases, a home screen may be a screen that is displayed by HVAC controller 20 as a default display, or when no other data entry is underway. A home screen may, if desired, display one or more parameters relating to environmental conditions such as indoor and/or outdoor temperature and/or humidity, expected weather conditions, and/or the status of any equipment that is at least partially controlled by HVAC controller 20.

In Figure 3, HVAC controller 20 is displaying on display 22 a home screen 24 that includes a navigational bar 26 that may be considered as providing top level navigation. In some cases, if desired, navigation bar 26 may include one or more of a HOME button 28, a FAN button 30, a HEAT/COOL button 32 and/or a MENU button 34. The function of each button within navigational bar 26 will be

demonstrated, in turn. Figure 3 is an example of a screen that may be displayed after a user has pushed HOME button 28.

In some cases, home screen 24 may be considered as having two or more regions. For example, home screen 24 may include a first region 36 and a second region 38. In some instances, first region 36 may be considered as displaying or otherwise providing primary information while second region 38 may be considered as displaying or otherwise providing secondary information. In some cases, primary information may be information that is considered to be more important, more interesting and/or more useful than secondary information. To illustrate, first region 36 may display one or more of a current temperature reading, a current indoor humidity, a schedule status, and the like. Second region 38 may display one or more of a date and time, an outdoor temperature reading, an outdoor humidity reading, an equipment status, and the like.

Home screen 24 may also include a third region 40 that may be used for displaying and/or adjusting a parameter value such as a parameter that is displayed within first region 36 of home screen 24. In some cases, for example, third region 40 may include a parameter 42, an up arrow 44 and a down arrow 46. The value of parameter 42 may be increased or decreased using, as necessary, up arrow 44 and/or down arrow 46.

As illustrated, second region 38 may refer to a left-hand section of home screen 24, third region 40 may refer to a right-hand section of home screen 24 and first region 36 may refer to a center section of home screen 24 that is between second region 38 and third region 40. In some instances, however, one or more of first region 36, second region 38 and/or third region 40 may instead be aligned vertically above or below the other regions within home screen 24, as desired.

In Figure 4, HVAC controller 20 is displaying on display 22 a home screen 48 that is similar in many ways to home screen 24 (Figure 3). Home screen 48, however, includes a third region 50 that may be used to display and/or adjust two different parameter values. For example, third region 50 may, as illustrated, display both a heating temperature set point and a cooling temperature set point, but this is not required. Third region 50 may include a first parameter 52, a first up arrow 54 and a first down arrow 56. Third region 50 may include a second parameter 58, a second up arrow 60 and a second down arrow 62. First parameter 52 may be adjusted up or down using first up arrow 54 and/or first down arrow 56, as appropriate. Second

parameter 58 may be adjusted up or down using second up arrow 60 and/or second down arrow 62, as desired.

In some instances, pressing up arrow 44 and/or down arrow 46 (Figure 3) may cause HVAC controller 20 to display on display 22 a home screen 64 as shown in
5 Figure 5. Home screen 64 may, as illustrated, include a hold bar 66 that is displayed along a portion of display 22. Hold bar 66 may include one or more of an adjustable time button 68, a resume schedule button 70, a permanent hold button 72 and a done button 74. The adjustable time button 68 may include an up arrow 76 and a down arrow 78. A user may adjust an ending time for a temperature hold by pressing up
10 arrow 76 and/or down arrow 78, as appropriate. If a user changes their mind, and wishes to instead return to the programmed schedule, they may do so simply by pressing resume schedule button 70. Once they have adjusted the ending time as desired, they may press done button 74.

Figure 6 is similar to Figure 5, but includes third region 50 as originally
15 discussed with respect to Figure 4. Figure 6 shows a home screen 80 that might be displayed by HVAC controller if a user has pressed or one or more of first up arrow 54, first down arrow 56, second up arrow 60 and/or second down arrow 62 to adjust a temperature set point.

Figure 7 provides an illustrative home screen 116 that may be displayed if Fan
20 button 30 is pressed. In some cases, a Help button 118 may be displayed, for example, within second region 38. By pressing Help button 118, a homeowner or other individual may obtain additional information regarding the choices they are being asked to make (i.e. context sensitive help information). First region 36 may include one or more fan buttons that can be pressed to instruct HVAC controller 20
25 how to operate the fan present within the HVAC equipment. The fan buttons may include, for example, one or more of a Run Continuously button 120, an Automatic button 122, an Intermittent button 124 and/or a Run Fan with Schedule button 126. As there may be more fan buttons than can be displayed at one time within first region 36, third region 40 may include an up scroll button 128 and a down scroll button 130
30 in order to scroll through the available fan buttons.

Figure 8 provides an illustrative help screen 132 that may be provided by HVAC controller 20 if a homeowner or other individual presses Help button 118 within screen 116 (Figure 7). Second region 38 may include a Back button 133 that permits an individual to return to the previous screen (e.g. Figure 7) once they have

read and understood the information provided within help screen 132. In the illustrative embodiment, first region 36 includes context sensitive textual information, providing the individual with information pertaining to the fan choices presented within screen 116. That is, the particular help information that is provided is preferably contextual to the particular task at hand. Third region 40 includes up scroll button 128 and down scroll button 130 in order to scroll up and down through the text provided within first region 36, if necessary.

Figure 9 provides an illustrative home screen 134 that may be displayed if Heat/Cool button 32 is pressed. In some cases, a Help button 136 may be displayed within second region 38. By pressing Help button 136, a homeowner or other individual may obtain additional information regarding the choices they are being asked to make. First region 36 may include one or more selection buttons that can be pressed to instruct HVAC controller 20 how to operate the HVAC equipment. The selection buttons may include, for example, one or more of a Heating button 138, a Cooling button 140, an Automatic button 142, an Off button 144 and/or an Emergency Heat button 146. As there may be more selection buttons than can be displayed at one time within second region 38, third region 40 may include an up scroll button 128 and a down scroll button 130 in order to scroll through the available selection buttons.

Figure 10 provides an illustrative help screen 148 that may be provided by HVAC controller 20 if a homeowner or other individual presses Help button 136 within home screen 134 (Figure 9). Second region 38 may include a Back button 133 that permits an individual to return to the previous screen (e.g. Figure 9) once they have read and understood the information provided within help screen 132. As discussed above, first region 36 may include context sensitive textual information providing the individual with information pertaining to the selection choices presented within home screen 116. Third region 40 includes up scroll button 128 and down scroll button 130 in order to scroll up and down through the displayed text.

It will be appreciated that while help screens 132 and 148 shown herein provide the user with information pertaining to fan settings (help screen 132) and heating/cooling settings (help screen 148), HVAC controller 20 may be configured to provide context-sensitive help screens that pertain to virtually any screen that HVAC controller 20 may display that solicits a choice or setting from a user. For example, HVAC controller 20 may provide context-sensitive help screens pertaining to

equipment selections and equipment parameters, scheduling and other onscreen programming, and the like. HVAC controller 20 may be configured to include a Help button (like Help button 118 or 136) on any screen that includes a user selection and/or setting, as desired.

5 As can be seen, a HVAC controller such as a thermostat (20) may be configured to control one or more components of an HVAC system. The HVAC controller (20) may include a controller (12) configured to operate an algorithm that at least partially controls the one or more components of an HVAC system. The algorithm may include a plurality of operating parameters. In some instances, the HVAC controller may include a touch screen dot matrix display (22) coupled to the controller (12), but this is not required. When so provided, the touch screen dot matrix display (22) may be configured to display one or more of the plurality of operating parameters and solicit values for the displayed operating parameters. In some instances, the controller (12) may also display on the touch screen dot matrix display (22) a help button (118; 136) that, if pressed, the controller (12) displays a context sensitive help screen (132; 148) that provides information relative to the displayed operating parameters. In some cases, the help information is displayed in place of the displayed operating parameters, but this is not required. The displayed operating parameters may relate to one or more of circulating fan operation, system operation, scheduling, humidification, dehumidification, ventilation settings, maintenance reminders, equipment settings, and/or any other suitable operating parameter(s), as desired.

15 In some instances, the help screen(s) (132; 148) may include a back button (133) that, if pressed, causes the controller to revert back to a previous screen including the previously displayed operating parameters. Also, it is contemplated that the help screen(s) (132; 148) may include scroll buttons (128; 130) that may be used to scroll up and down through the help information, if necessary.

20 To help enhance the usefulness and increase the context of the help information, it is contemplated that the information displayed in the help screen (132; 148) may include embedded variables. Current values of the embedded variables may be incorporated into the help information that is displayed.

 In some cases, the HVAC controller (20) may be configured to display a menu structure having one or more menu screens (116; 134) that each have two or more menu options. It is contemplated that for at least one of the menu screens (116; 134)

that has two or more menu options, the controller may also display a help button (118; 136) that, if pressed, causes the controller (12) to display a context sensitive help screen (132; 148) that provides information relative to at least some of the displayed menu options. In some cases, the context sensitive help screen is displayed in place
5 of the menu screen (116; 134). Also, the help screen (132; 148) may include a back button (133) that, if pressed, causes the controller to revert back to the menu screen (116; 134), but this is not required in all embodiments.

Figure 11 provides an illustrative home screen 150 that may be displayed if Menu button 34 is pressed. HVAC controller 20 may display a variety of menu items
10 within first region 36 and/or within second region 38. In the illustrative embodiment, third region 40 includes up scroll button 128 and down scroll button 130 to scroll up and down the displayed menu items, if necessary. These menu items may permit a homeowner or other individual to set a variety of parameters of HVAC controller 20.

In some cases, home screen 150 may include, for example, one or more of a
15 Create/Edit Schedule button 152, a Vacation Mode button 154, an Humidification button 156, a Dehumidification button 158, a Ventilation button 160, a System Information button 162, a Date/Time button 164, a Preferences button 166, a Temporary Schedule Changes button 168, a Schedule Fan button 170, a Southern Dehumidification Mode button 172, a Find Remote button 174, a Clean Screen button
20 176, a Security Settings button 178 and/or an Installer Set Up button 180. Subsequent Figures will provide illustrative screens that may be displayed by HVAC controller 20 in response to a homeowner or other individual selecting one or more of these menu items.

Figures 12 through 17 provide illustrative but non-limiting examples of
25 screens that may be displayed by HVAC controller 20 pertaining to changing and/or viewing humidification and dehumidification settings within HVAC controller 20. In particular, Figures 12-15 provide illustrative screens that may be displayed by HVAC controller 20 in response to someone pressing or otherwise selecting Humidification button 156 (Figure 11), and Figures 16-17 provide illustrative screen that may be
30 displayed by HVAC controller 20 in response to someone pressing or otherwise selecting Dehumidification button 158 (Figure 11).

Figure 12 provides an illustrative screen 522 that may include text 524 instructing the user to select or set their humidification setting. HVAC controller 20 may, for example, use the humidification setting in controlling a humidifier such as a

whole-house humidifier. HVAC controller 20 may, for example, display a parameter adjustment element for use in adjusting an operating parameter such as humidification. The parameter adjustment element may include an indicator that provides a qualitative indication for at least the current setting of the operating
5 parameter.

To illustrate, screen 522 includes a slider bar 526 that has a scale 528, a display 530, a Left arrow 532 and a Right arrow 534. Scale 528 can be seen as including text describing the humidification setting in relative or qualitative terms such as “Dry”, “Comfort Zone” and “Wet”. These particular terms are merely
10 representative, as other terms may also be used. More generally, scale 528 may provide a qualitative context to a particular humidity value (e.g. 42%) so that a user unfamiliar with humidity values can still choose an appropriate humidity setting.

Display 530 may, as illustrated, provide a reminder that it is the indoor humidity setting that is being displayed as well as a current indoor humidity setting or
15 current indoor humidity reading. Figure 13 provides an illustrative screen 536 having a display 538 that provides a display of the current indoor humidity setting or reading as well as an indication that frost protection has been activated, as will be discussed with respect to subsequent Figures.

Returning to Figure 12, slider bar 526 may be seen as including an indicator
20 button 540 that may be moved left and/or right using left arrow 532 and/or right arrow 534, as desired. Indicator button 540 may, with respect to scale 528, provide a visual indication of the relative or qualitative humidity setting and may, if desired, include a pointer that interacts with scale 528. Scale 528 may provide upper and/or lower numerical limits for the displayed parameter. In some instances, indicator button 540
25 may include a numerical representation of the indoor humidity setting.

In some cases, indicator button 540 may move a prescribed distance either left or right in response to the user pressing either left arrow 532 or right arrow 534. In some cases, the distance that indicator button 540 moves may be at least partially a function of how many times left arrow 532 and/or right arrow 534 are pressed. In
30 some instances, the distance that indicator button 540 moves may be at least partially a function of how long left arrow 532 and/or right arrow 534 are held down by the user. In some cases, indicator button 540 may be a touch-sensitive button, and may be moved left or right simply by the user touching indicator button 540 and dragging their finger left or right.

Screen 522 may include a Disable Humidification button 542. In some cases, a user may not wish to provide HVAC controller 20 with humidification settings. For example, in warm climates, the user may not want or need to operate a humidifier such as a whole-house humidifier that is controlled by HVAC controller 20. In some cases, a user's HVAC equipment may not include any humidification equipment. In situations such as these, the user may deactivate this functionality by pressing Disable Humidification button 542. Figure 14 provides an illustrative screen 552 that is similar to screen 522 (Figure 12), but shows that HVAC controller 20 has grayed out slider bar 526 as a result of the user having pressed Disable Humidification button 542. It can be seen that text 524 also states that humidification has been disabled. In some cases, screen 552 may include an Enable Humidification button 554.

Returning to Figure 12, screen 522 may include a Window Frost Protection Setting button 544, as will be discussed with respect to Figures 15 and 16 below. A Help button 546 may, if pressed, provide further context sensitive help information explaining, for example, humidification, providing clarification regarding options, and the like. A Cancel button 548, if pressed, may cause HVAC controller 20 to revert to screen 150 (Figure 11) without saving any changes that may have been made. A Done button 550, if pressed, informs HVAC controller 20 that the humidification setting has been completed, and as a result, may revert to screen 150 (Figure 11) and save any changes.

Pressing Window Frost Protection Setting button 544 (Figure 12) may cause HVAC controller 20 to display an illustrative screen 556, as shown in Figure 15. In some ways, selecting an indoor humidification setting is similar to selecting a window frost protection setting, as the risk of window condensation, particularly in cold weather, is at least partially a function of the indoor air humidity. However, window condensation is also at least partially a function of the efficiency of the windows within the house or other building.

An old, inefficient window such as a single-pane window may present a relatively cold glass surface to the heated atmosphere within the building. Condensation is more likely in this situation. In contrast, a newer, more efficient window such as a double-pane window or even a triple-pane window will present a relatively warmer glass surface to the heated atmosphere within the building. Thus, an efficient window may tolerate a relatively higher indoor humidity without excessive window condensation. It will be recognized, of course, that outdoor

temperature may also play a part. In some cases, HVAC controller 20 may be in communication with an exterior temperature sensor and may be programmed to adjust humidity settings and/or window frost protection settings accordingly.

Screen 556 may include text 558 that informs the user that they are to select a setting for window frost protection. Screen 556 includes a slider bar 560 that has a scale 562, a display 564, a left arrow 532 and a right arrow 534. Scale 562 may include text describing the window frost protection setting in relative or qualitative terms such as “Less Efficient” and “More Efficient”. It will be recognized that this refers to the relative efficiency of the windows within the building. Display 564 may, as illustrated, provide a reminder that it is the window energy efficiency setting that is being displayed.

Slider bar 560 may be seen as including an indicator button 563 that may be moved left and/or right using left arrow 532 and/or right arrow 534, as desired. Indicator button 563 may, with respect to scale 562, provide a visual indication of the relative or qualitative humidity setting and may, if desired, include a pointer that interacts with scale 562. In some instances, indicator button 563 may include a numerical representation of the window frost protection setting.

Indicator button 563 may be moved using either left arrow 532 or right arrow 534. In some cases, the distance that indicator button 563 moves may be at least partially a function of how many times or for how long left arrow 532 and/or right arrow 534 are pressed. In some cases, indicator button 563 may be a touch-sensitive button, and may be moved left or right simply by the user touching indicator button 563 and dragging their finger left or right. A Humidification Setting button 565 may be pressed if the user wishes to return to screen 522 (Figure 12) to alter the humidification setting. Cancel button 548, if pressed, may cause HVAC controller 20 to revert to screen 150 (Figure 11) without saving any changes that may have been made. Done button 550, if pressed, informs HVAC controller 20 that the window frost protection setting has been completed, and as a result, may revert to screen 150 (Figure 11) and save the settings.

Figure 16 shows an illustrative screen 566 that may include text 568 instructing the user to select or set their dehumidification setting. HVAC controller 20 may, for example, use the dehumidification setting to control operation of a dehumidifier or an air exchanger. Screen 566 includes a slider bar 570 that has a scale 572, a display 574, a Left arrow 532 and a Right arrow 534. Scale 572 can be

seen as including text describing the dehumidification setting in relative or qualitative terms such as “Dry”, “Comfort Zone” and “Wet”. These particular terms are merely representative, as other terms may also be used. More generally, scale 572 may provide a qualitative context to a particular humidity value (e.g. 42%) so that a user unfamiliar with humidity values can still choose an appropriate dehumidification setting.

Display 574 may, as illustrated, provide the current indoor humidity setting or current indoor humidity reading. Slider bar 570 may be seen as including an indicator button 576 that may be moved left and/or right using left arrow 532 and/or right arrow 534, as desired. Indicator button 576 may, with respect to scale 528, provide a visual indication of the dehumidification setting and may, if desired, include a pointer that interacts with scale 574. In some instances, indicator button 576 may include a numerical representation of the indoor humidity setting.

Indicator button 576 may be moved using either left arrow 532 or right arrow 534. In some cases, the distance that indicator button 576 moves may be at least partially a function of how many times or for how long left arrow 532 and/or right arrow 534 are pressed. In some cases, indicator button 576 may be a touch-sensitive button, and may be moved left or right simply by the user touching indicator button 562 and dragging their finger left or right.

Screen 566 may, as illustrated, include a Disable Dehumidification button 578. Pressing Disable Dehumidification button 578 may cause HVAC controller 20 to display an illustrative screen 580 as shown in Figure 17. It can be seen that in screen 580, slider bar 570 has been grayed out. Text 568 may also include a message reminding the user that dehumidification has been disabled. The user may wish to disable dehumidification if, for example, their HVAC equipment does not include a dehumidifier or an air exchanger. In some cases, screen 580 may include an Enable Dehumidification button 582.

Returning to Figure 16, cancel button 548, if pressed, may cause HVAC controller 20 to revert to screen 150 (Figure 11) without saving any changes that may have been made. Done button 550, if pressed, informs HVAC controller 20 that the dehumidification setting has been completed, and as a result, may revert to screen 150 (Figure 11) and save the changes.

Figures 18 through 21 provide illustrative but non-limiting examples of screens that may be displayed by HVAC controller 20 pertaining to viewing and/or

changing preferences within HVAC controller 20. In particular, Figure 18 provides an illustrative screen 700 that may be displayed by HVAC controller 20 in response to someone pressing or otherwise selecting Preferences button 166 (Figure 11) in order to view and/or change preferences information.

5 Screen 700 includes a navigational bar 702 that may provide the user with information pertaining to where they are within the menu structure. A Previous Menu button 704 permits the user to, if desired, return to a previous menu. In some cases, pressing Previous Menu button 704 may cause HVAC controller 20 to revert to screen 150 (Figure 11). Screen 700 may include a number of menu items for which
10 preferences may be selected. In some cases, there may be more menu items than can be displayed at one time on screen 700. Thus, in some cases screen 700 may include an Up arrow button 730 and a Down arrow button 732 so that the user may scroll up and/or down through the menu items. In Figure 18, various menu items are shown including some that are shown outside of screen 700. It should be understood that this
15 is only illustrative, and that Up arrow button 730 and/or Down arrow button 732 may be used to scroll through these various menu items on screen 700.

In some instances, screen 700 may display one or more of a Reminders button 706, a Fahrenheit/Celsius button 708, a 12h/24h Clock button 710, a Display Options button 712, a Language Options button 714, a Schedule Options button 716, an
20 Adaptive Intelligent Recovery button 718, a Restore Energy Star Settings button 720, an Unoccupied Settings button 722, a Ventilation Settings button 724, a Wireless Device Manager button 726 and a Daylight Savings Time button 728.

If, for example, the user presses Display Options button 712, HVAC controller 20 may display an illustrative screen 776, as shown in Figure 19. Navigational bar
25 702 provides the user with an indication of where they are within the hierarchical menu structure. Previous Menu button 704 permits the user to revert to a previous screen. Screen 776 may include, for example, one or more a Backlight button 778, a Contrast button 780 and a Screensaver button 782. These are display options that can be customized or otherwise modified by the user.

30 Pressing Backlight button 778 of Figure 19 may cause HVAC controller 20 to display an illustrative screen 784, as shown in Figure 20. Screen 784 may include text 786 that instructs the user to set their inactive backlight level. A slider bar 788 includes a scale 790, a display 792, a Left arrow 794 and a Right arrow 796. Scale 790 may provide relative or qualitative terms such as dim and bright. Display 792

may, as illustrated, provide a reminder that it is the backlight level that is being set. Slider bar 788 includes an indicator 798 that may be moved left and/or right using left arrow 794 and/or right arrow 796, as desired. Indicator button 798 may, with respect to scale 790, provide a visual indication of the relative or qualitative backlight level and may, if desired, include a pointer that interacts with scale 790. In some instances, indicator button 798 may include a numerical representation of the backlight level setting. In some cases, the numerical representation may range from 0 to 10, or perhaps 1 to 10.

In some cases, the distance that indicator button 798 moves may be at least partially a function of how many times or for how long left arrow 794 and/or right arrow 796 are pressed. In some cases, indicator button 798 may be a touch-sensitive button, and may be moved left or right simply by the user touching indicator button 798 and dragging their finger left or right. Help button 744 may provide the user with further information. The user may cancel out, if desired, using Cancel button 762. Pressing Done button 752 may cause HVAC controller 20 to save any changes made and/or revert to a previous screen.

Returning briefly to Figure 19, pressing Contrast button 780 may cause HVAC controller 20 to display an illustrative screen 800, as shown in Figure 21. Screen 800 may include text 802 that instructs the user to set their contrast level. A slider bar 803 includes a scale 804, a display 806, a Left arrow 808 and a Right arrow 810. Scale 804 may provide relative or qualitative terms such as less contrast and more contrast. Display 806 may, as illustrated, provide a reminder that it is the contrast level that is being set. Slider bar 803 includes an indicator 812 that may be moved left and/or right using left arrow 808 and/or right arrow 810, as desired. Indicator button 812 may, with respect to scale 804, provide a visual indication of the relative or qualitative backlight level and may, if desired, include a pointer that interacts with scale 804. In some instances, indicator button 812 may include a numerical representation of the contrast level setting.

In some cases, the distance that indicator button 812 moves may be at least partially a function of how many times or for how long left arrow 808 and/or right arrow 810 are pressed. In some cases, indicator button 812 may be a touch-sensitive button, and may be moved left or right simply by the user touching indicator button 812 and dragging their finger left or right. Help button 744 may provide the user with further information. The user may cancel out, if desired, using Cancel button 762.

Pressing Done button 752 may cause HVAC controller 20 to save any changes made and/or revert to a previous screen.

As can be seen, an HVAC controller (10; 20) may be configured to control one or more components of an HVAC system. The HVAC controller (10, 20) may include any suitable display including, for example, a touch screen dot matrix display (22). The HVAC controller (10; 20) may further include a controller (12) that is in communication with the touch screen dot matrix display (22). The controller (12) may be configured to operate an algorithm that at least partially controls the one or more components of the HVAC system, wherein the algorithm includes (e.g. references) at least one operating parameter.

In some instances, the controller (12) may be configured to display on the touch screen dot matrix display (22) a parameter adjustment element (526; 560; 570; 788; 803) for use in adjusting one of the operating parameters. The parameter adjustment element (526; 560; 570; 788; 803) may include an indicator (528; 562; 572; 790; 804) that provides a qualitative indication for at least the current setting of the operating parameter. In some instances, the parameter adjustment element (526; 560; 570; 788; 803) may also indicate a quantitative value of the current setting of the operating parameter, an allowed range for the operating parameter, and/or a numerical value of the current setting of the operating parameter, if desired.

In some cases, the parameter adjustment element (526; 560; 570; 788; 803) may include a slider control (540, 563, 576; 798; 812) as well as the indicator (528; 562; 572; 790; 804) that provides the qualitative indication for the current setting of the operating parameter. It is contemplated that the slider control (540, 563, 576; 798; 812) may permit a user to alter a value of the operating parameter setting by moving a slider (540, 563, 576; 798; 812) between a left end and a right end (or top end and bottom end) of the slider control (540, 563, 576; 798; 812).

In some instances, the slider control (540, 563, 576; 798; 812) may include a horizontal bar, and a slider button (540, 563, 576; 798; 812) that is slidable on the horizontal bar. When so provided, a user may lower the value of the operating parameter by moving the slider button (540, 563, 576; 798; 812) to the left, and raise the value of the operating parameter by moving the slider button (540, 563, 576; 798; 812) to the right.

The disclosure should not be considered limited to the particular examples described above, but rather should be understood to cover all aspects of the invention

as set out in the attached claims. Various modifications, equivalent processes, as well as numerous structures to which the invention can be applicable will be readily apparent to those of skill in the art upon review of the instant specification.

WHAT IS CLAIMED IS:

1. An HVAC controller (10; 20) configured to control one or more components of an HVAC system, the HVAC controller (10; 20) comprising:
 - a touch screen dot matrix display (22);
 - a controller (12) in communication with the touch screen dot matrix display (22), the controller (12) configured to operate an algorithm that at least partially controls the one or more components of the HVAC system, the algorithm including an operating parameter; and
 - the controller (12) configured to display on the touch screen dot matrix display (22) a parameter adjustment element (526; 560; 570; 788; 803) for use in adjusting the operating parameter, the parameter adjustment element (526; 560; 570; 788; 803) including an indicator (528; 562; 572; 790; 804) that provides a qualitative indication for at least the current setting of the operating parameter.
2. The HVAC controller (10; 20) of claim 1, wherein the indicator (528; 562; 572; 790; 804) that provides the qualitative indication for the current setting of the operating parameter indicates a comfort zone for the particular operating parameter.
3. The HVAC controller (10; 20) of claim 1, wherein the parameter adjustment element (526; 560; 570; 788; 803) further indicates a quantitative value of the current setting of the operating parameter.
4. The HVAC controller (10; 20) of claim 1-3, wherein the parameter adjustment element (526; 560; 570; 788; 803) further indicates an allowed range for the operating parameter.
5. The HVAC controller (10; 20) of claim 2, wherein the parameter adjustment element (526; 560; 570; 788; 803) indicates a numerical value of the current setting of the operating parameter.
6. The HVAC controller (10; 20) of claim 1, wherein the parameter adjustment element (526; 560; 570; 788; 803) includes a slider control (540, 563, 576; 798; 812) as well as the indicator (528; 562; 572; 790; 804) that provides the

qualitative indication for the current setting of the operating parameter, the slider control (540, 563, 576; 798; 812) permitting a user to alter a value of the operating parameter setting by moving a slider (540, 563, 576; 798; 812) between a left end and a right end of the slider control (540, 563, 576; 798; 812).

7. The HVAC controller (10; 20) of claim 6, wherein the slider control (540, 563, 576; 798; 812) includes a horizontal bar and a slider button (540, 563, 576; 798; 812) that is slidable on the horizontal bar.

8. The HVAC controller (10; 20) of claim 7, wherein a user may lower the value of the operating parameter by moving the slider button (540, 563, 576; 798; 812) to the left, and raise the value of the operating parameter by moving the slider button (540, 563, 576; 798; 812) to the right.

9. The HVAC controller (10; 20) of claim 8, wherein the slider button (540, 563, 576; 798; 812) may be moved left and right by a user touching the slider button (540, 563, 576; 798; 812) on the touch screen dot matrix display and dragging the slider button (540, 563, 576; 798; 812) to the left and to the right.

10. A method for aiding in adjusting an operating parameter of an HVAC controller (10; 20), comprising:

displaying a parameter adjustment element (526; 560; 570; 788; 803) on a display, the parameter adjustment allowing a user to adjust a current setting of the operating parameter within an allowed range; and

displaying an indicator (528; 562; 572; 790; 804) that provides a qualitative indication to the user for at least the current setting of the operating parameter.

11. The method of claim 10 further comprising:
displaying a quantitative value of the current setting of the operating parameter.

12. A thermostat (20) configured to control one or more components of an HVAC system, the thermostat (20) comprising:

a controller (12) configured to operate an algorithm that at least partially controls the one or more components of the HVAC system, the algorithm including a plurality of operating parameters; and

a touch screen dot matrix display (22) coupled to the controller (12), the touch screen dot matrix display (22) being configured to display one or more of the plurality of operating parameters and solicit values for the displayed operating parameters;

wherein the controller (12) also displays on the touch screen dot matrix display (22) a help button (118; 136) that, if pressed, causes the controller (12) to display a context sensitive help screen (132; 148) that provides information relative to the displayed operating parameters.

13. The thermostat (20) of claim 12, wherein the information is displayed in place of the displayed operating parameters.

14. The thermostat (20) of claim 13, wherein the help screen (132; 148) includes a back button (133) that, if pressed, causes the controller to revert back to a previous screen including the displayed operating parameters.

15. The thermostat (20) of claim 12, wherein the help screen (132; 148) includes scroll buttons (128; 130) that may be used to scroll up and down through the information relative to the displayed operating parameters.

16. The thermostat (20) of claim 12, wherein the information displayed on the help screen (132; 148) includes embedded variables, wherein the current values of the embedded variables are displayed in the information.

17. The thermostat (20) of claim 12, wherein the displayed operating parameters relate to one or more of circulating fan operation, system operation, scheduling, humidification, dehumidification, ventilation settings, maintenance reminders, and equipment settings.

18. A thermostat (20) configured to control one or more components of an HVAC system, the thermostat (20) comprising:

a controller (12) configured to operate an algorithm that at least partially controls the one or more components of the HVAC system; and

a touch screen dot matrix display (22) coupled to the controller (12), the touch screen dot matrix display (22) configured to display a menu structure having one or more menu screens (116, 134) that each have two or more menu options;

wherein on at least one of the menu screens (116; 134) that has two or more menu options, the controller also displays on the touch screen dot matrix display (22) a help button (118; 136) that, if pressed, causes the controller (12) to display a context sensitive help screen (132; 148) that provides information relative to the menu options on the at least one of the menu screens (116; 134).

19. The thermostat (20) of claim 18, wherein the information is displayed in place of the menu screen (116, 134).

20. The thermostat (20) of claim 18, wherein the help screen (132; 148) includes a back button (133) that, if pressed, causes the controller to revert back to the menu screen (116; 134).

21. A method for providing help to a user of a thermostat (20), the method comprising:

displaying on a touch screen dot matrix display a menu screen (116; 134) that has two or more menu options;

displaying a help button (118; 136) on the menu screen (116; 134); and

pressing the help button (118; 136), and in response, displaying a context sensitive help screen (132; 148) that provides information relative to the menu options on the menu screen (116; 134).

22. The method of claim 21, wherein the information is displayed in place of the menu screen (116; 134).

23. The method of claim 21, wherein the help screen (132; 148) includes a back button (133) that, if pressed, causes the controller to revert back to the screen (116; 134).

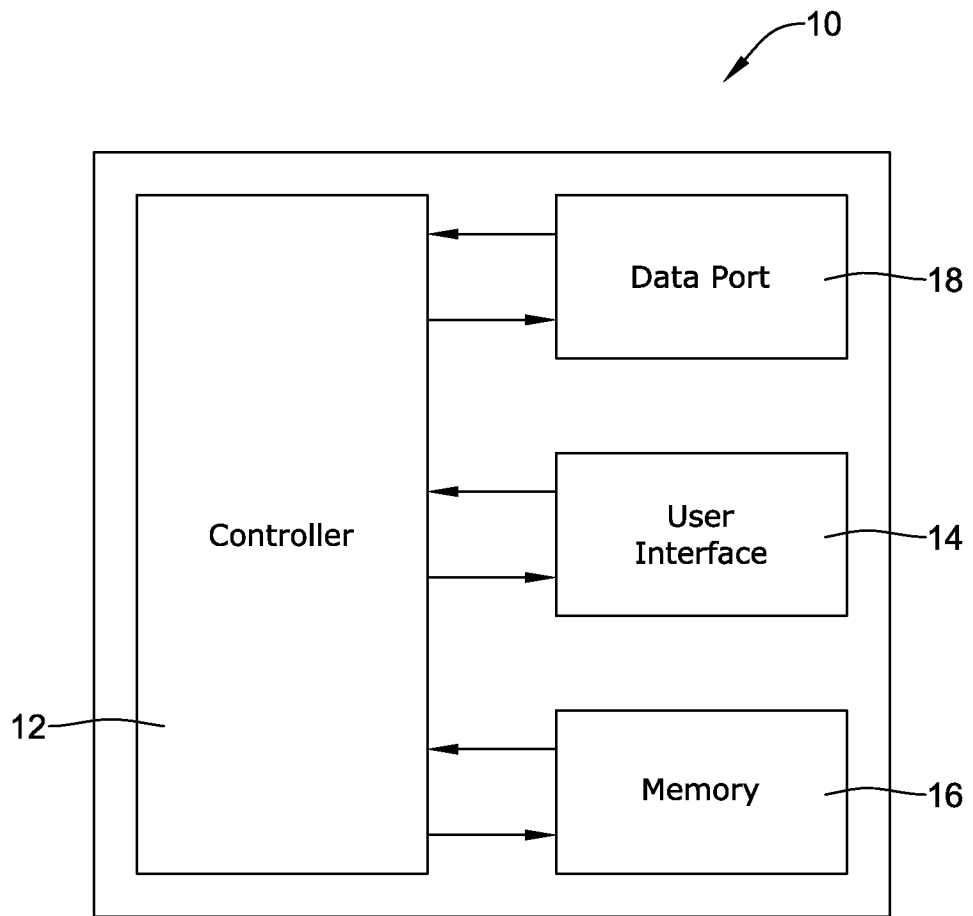

Figure 1

2\13

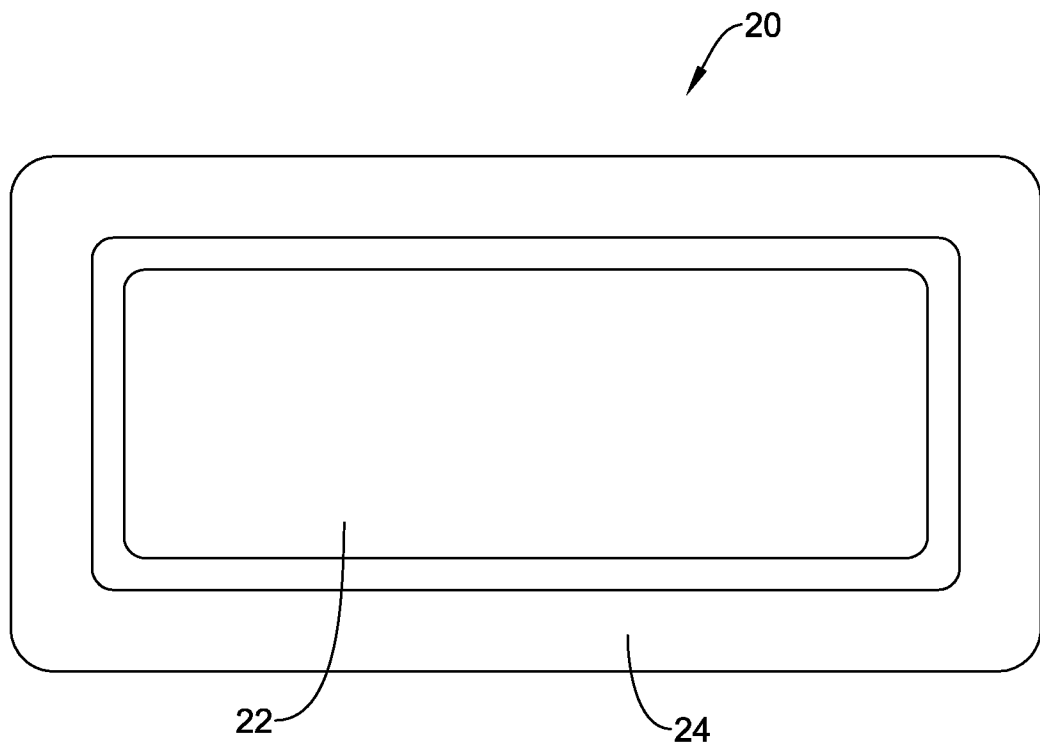

Figure 2

3\13

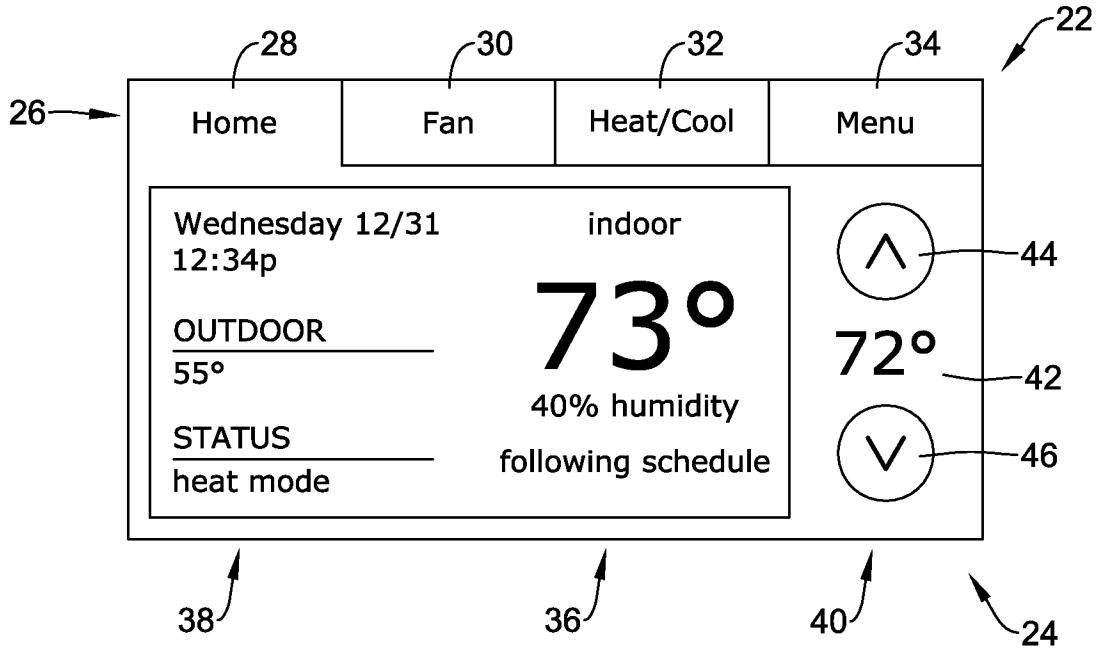

Figure 3

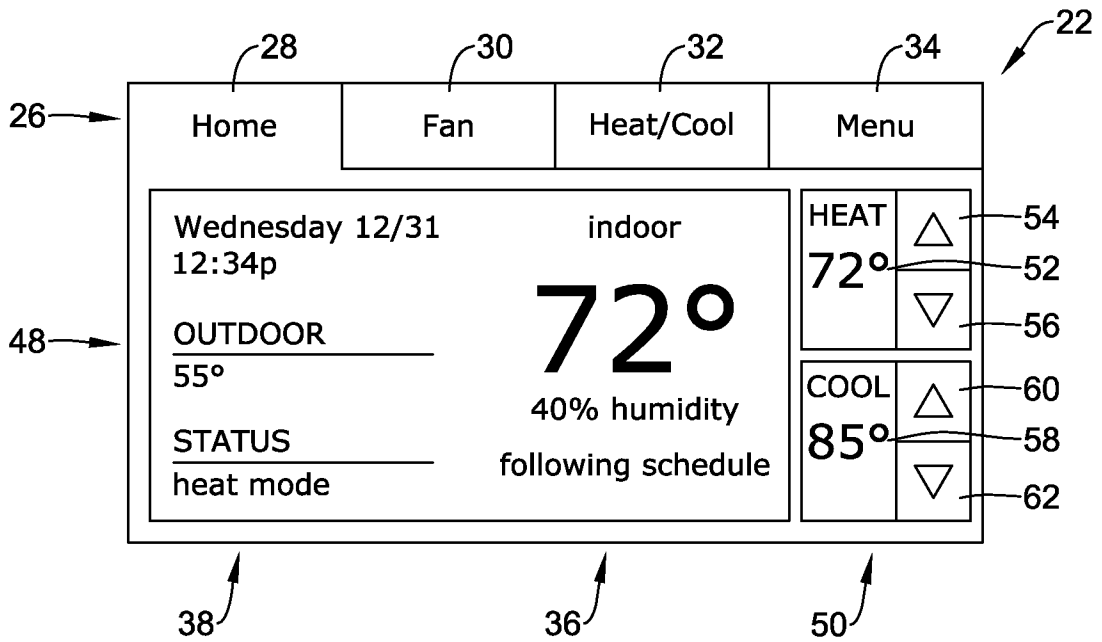

Figure 4

4\13

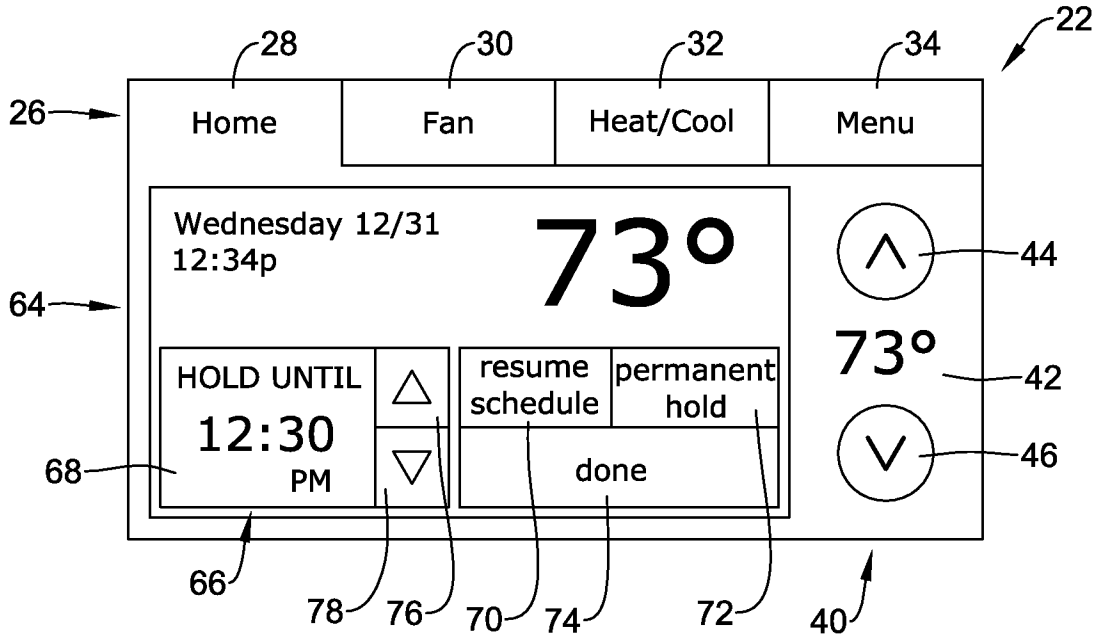

Figure 5

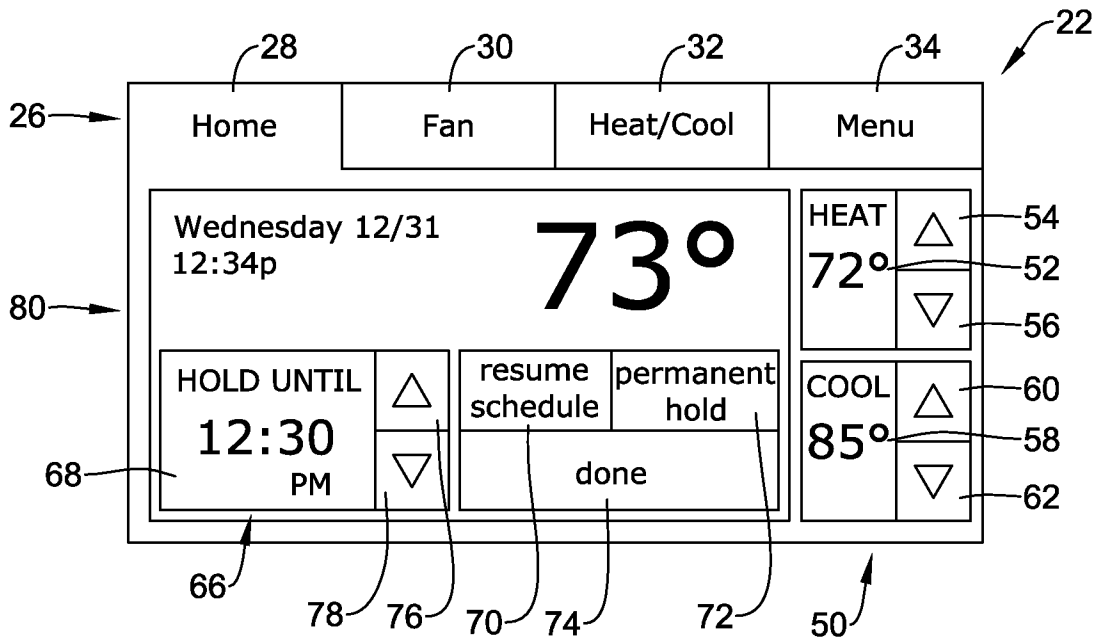

Figure 6

5\13

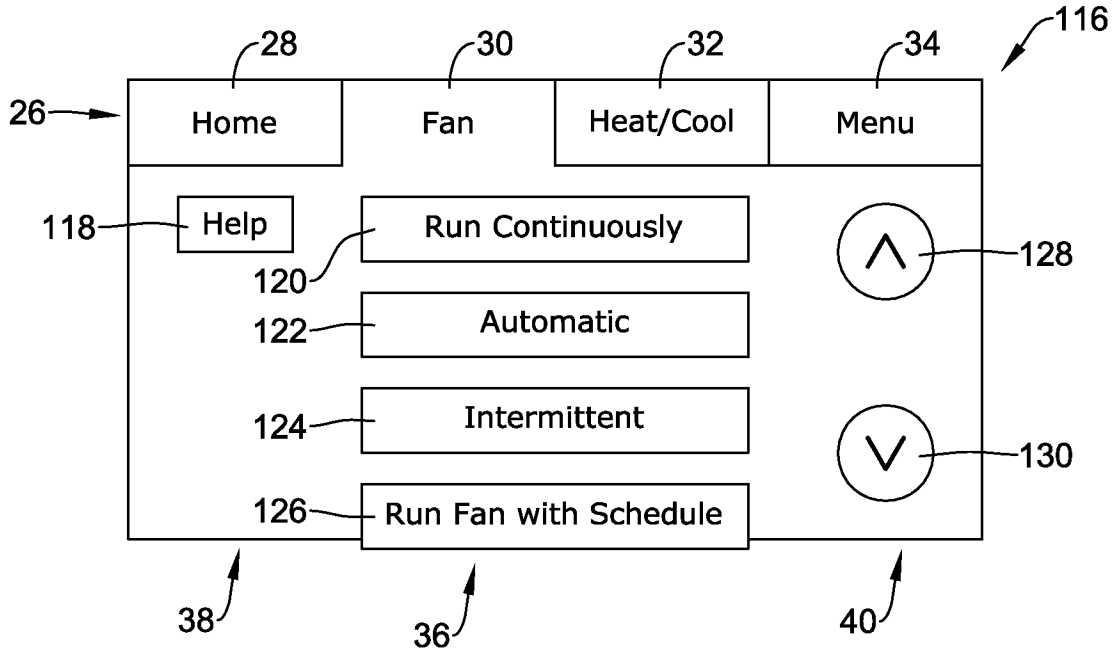

Figure 7

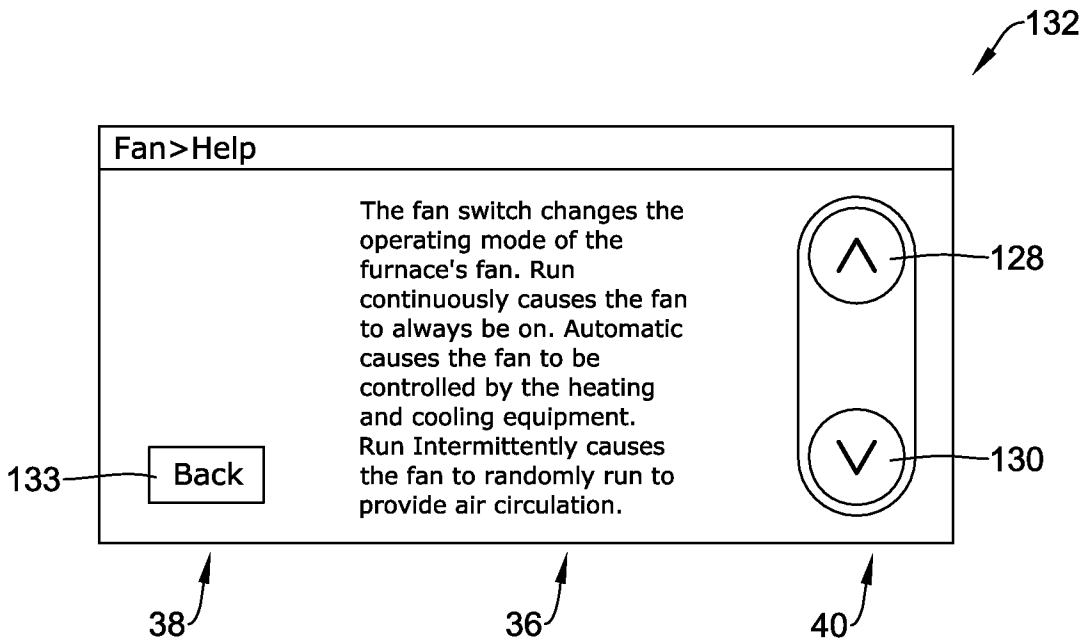

Figure 8

6\13

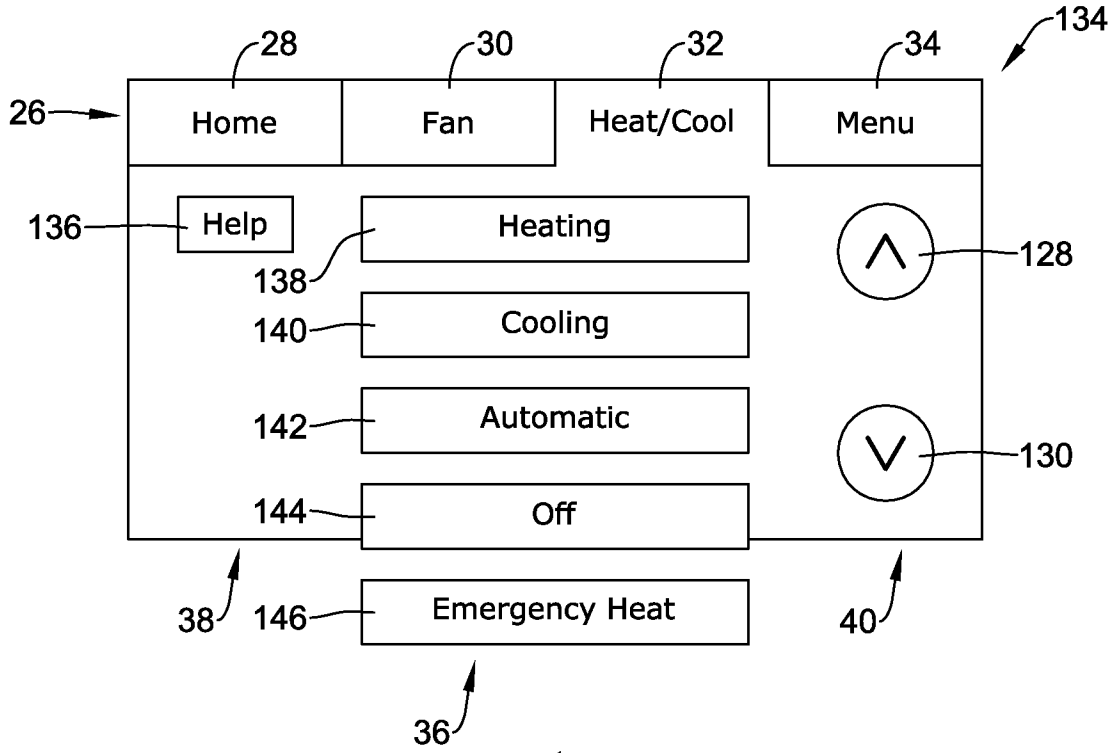

Figure 9

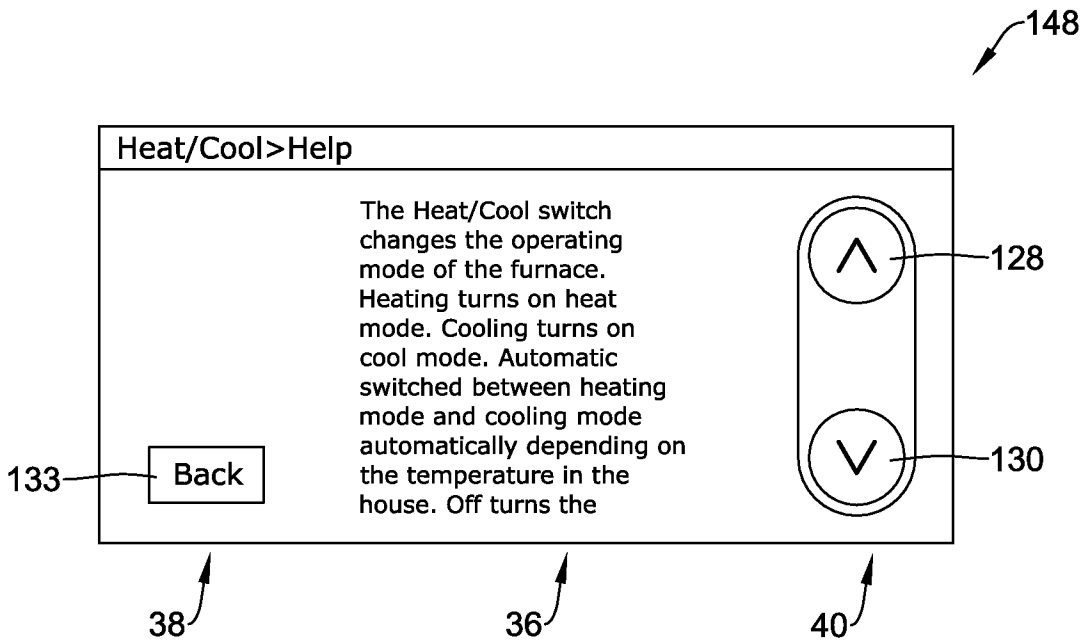

Figure 10

7\13

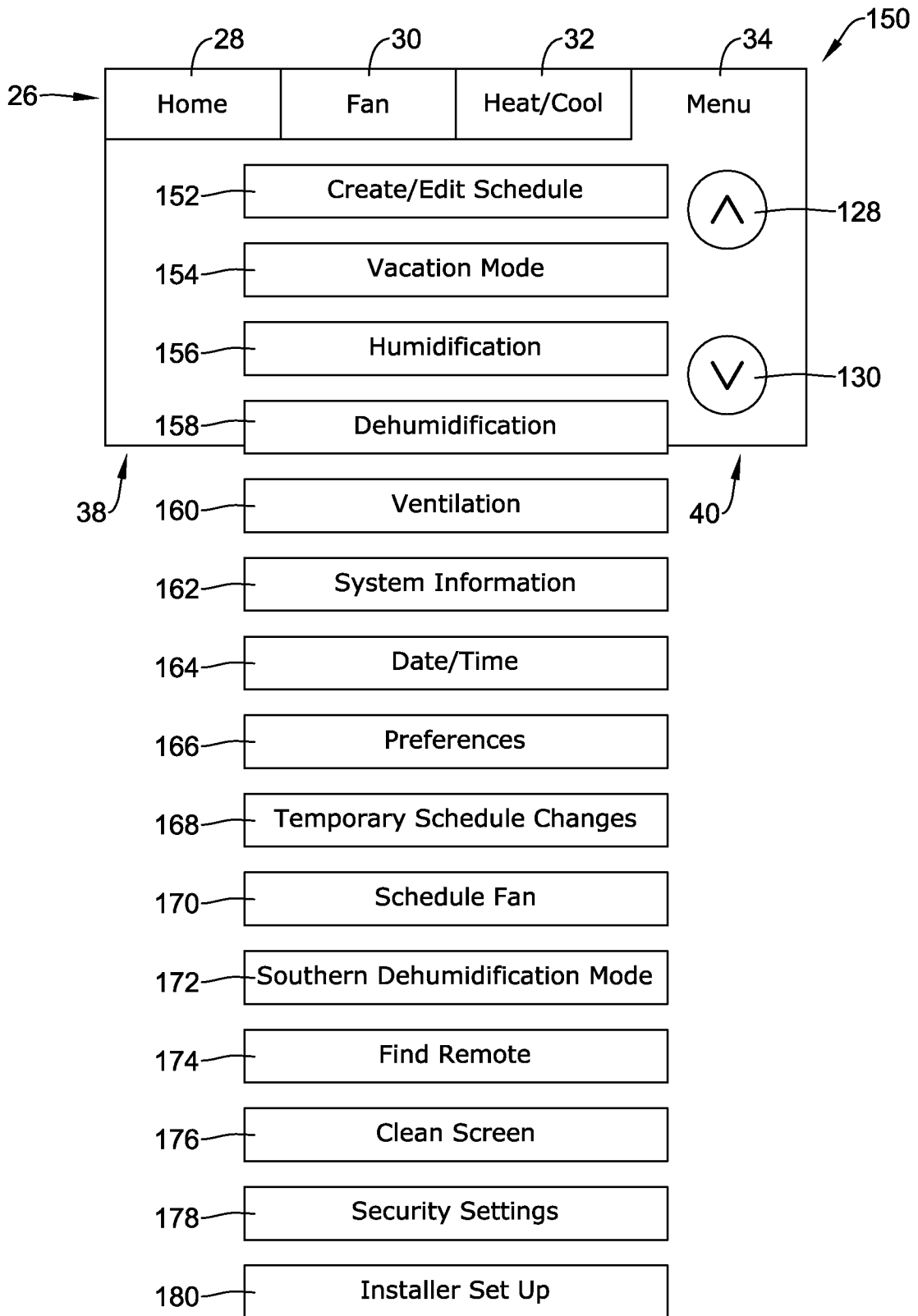

Figure 11

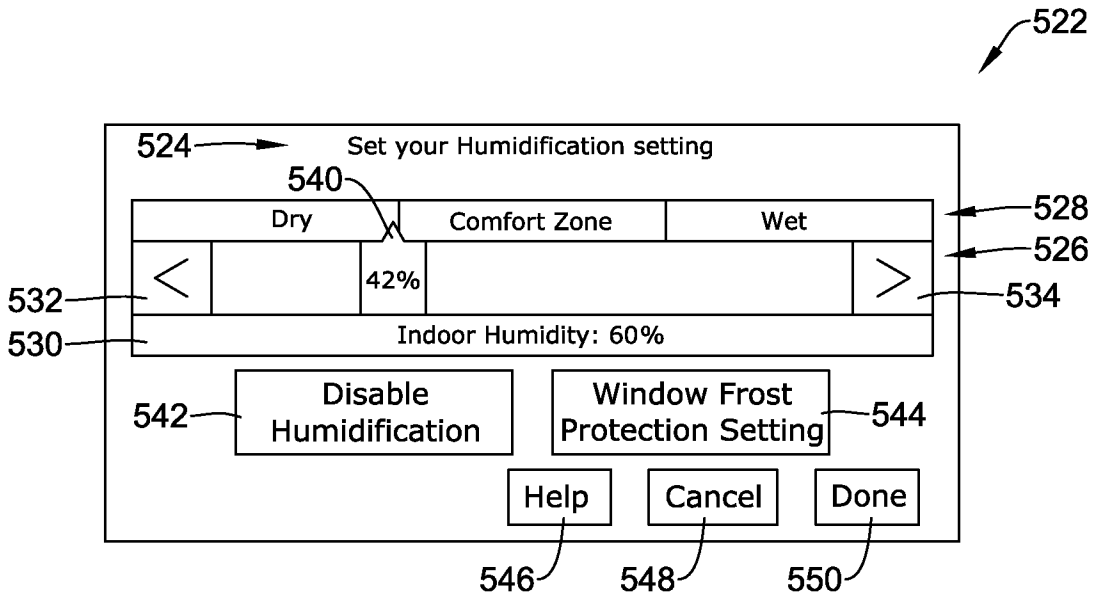

Figure 12

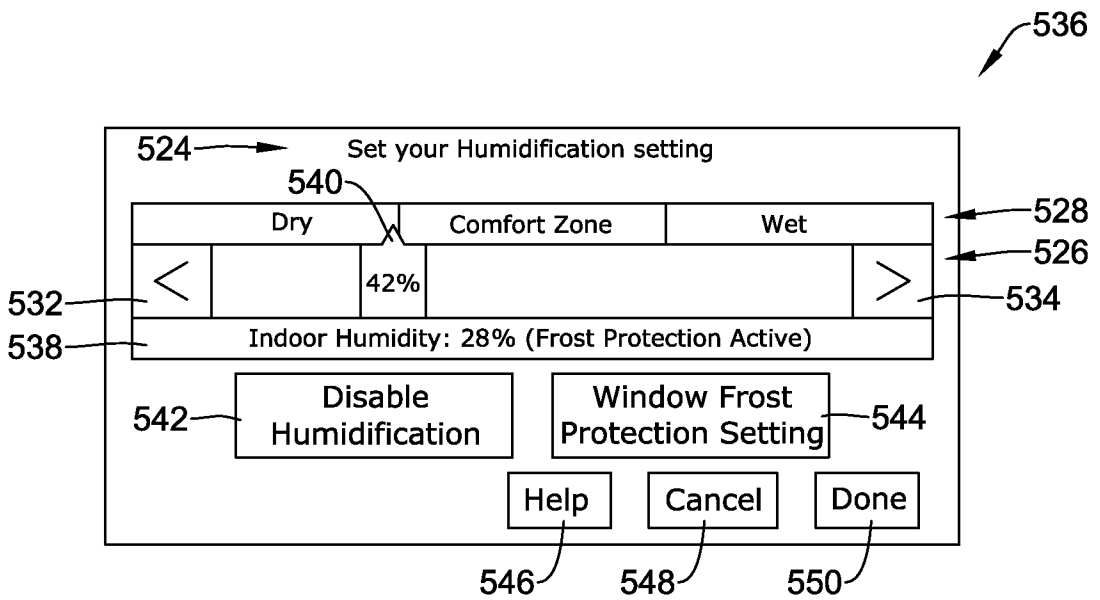

Figure 13

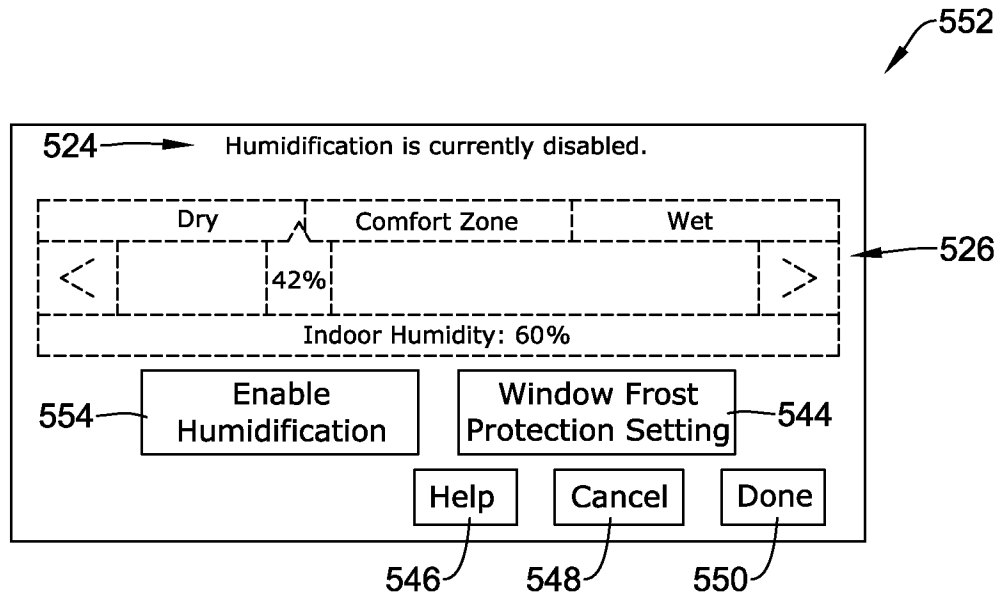

Figure 14

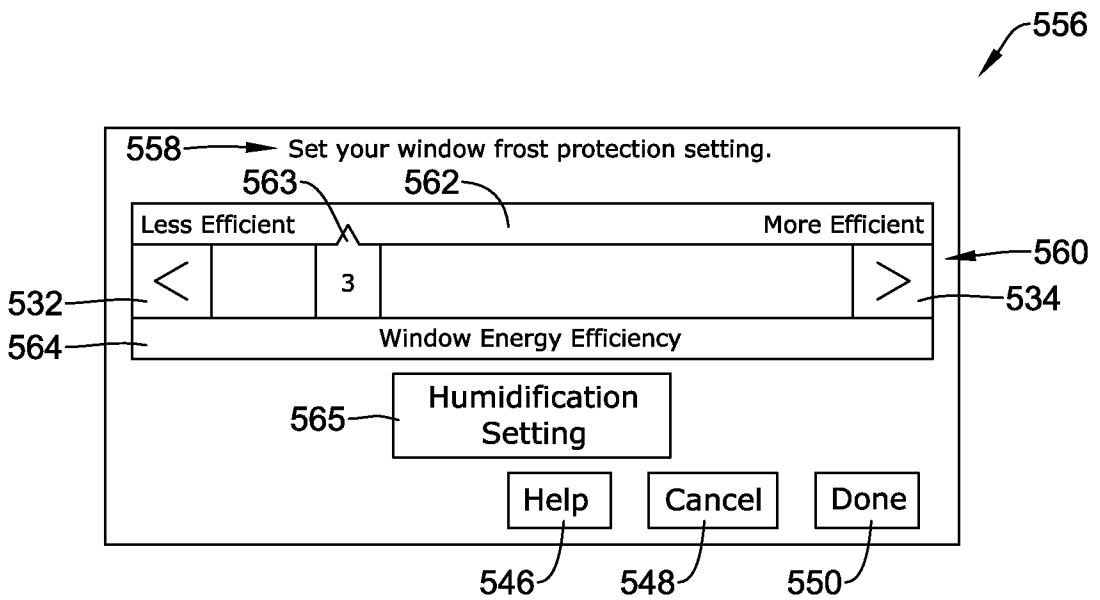

Figure 15

10\13

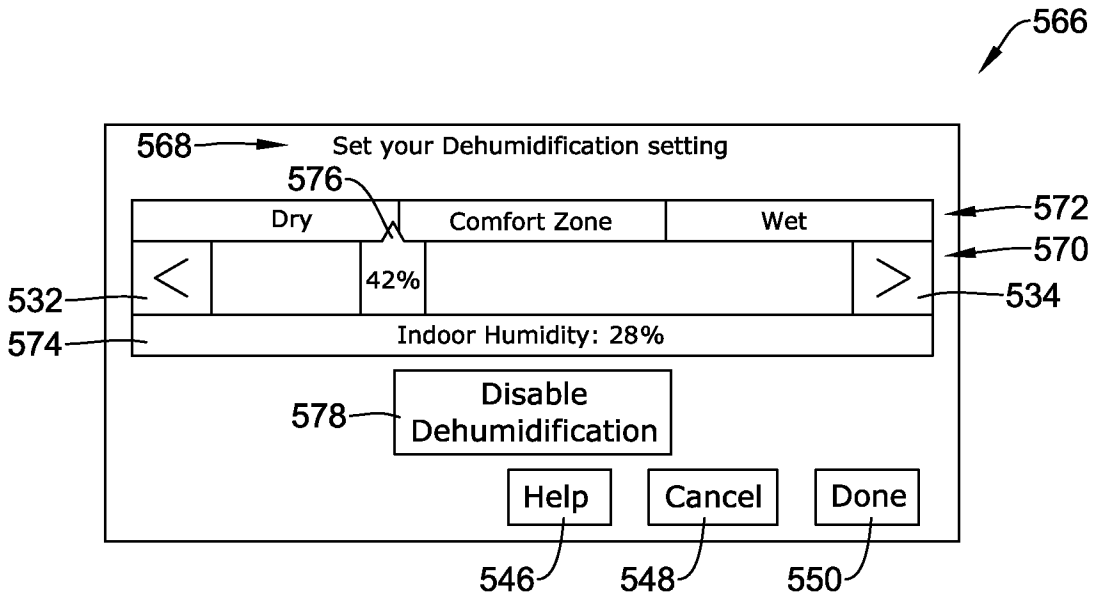

Figure 16

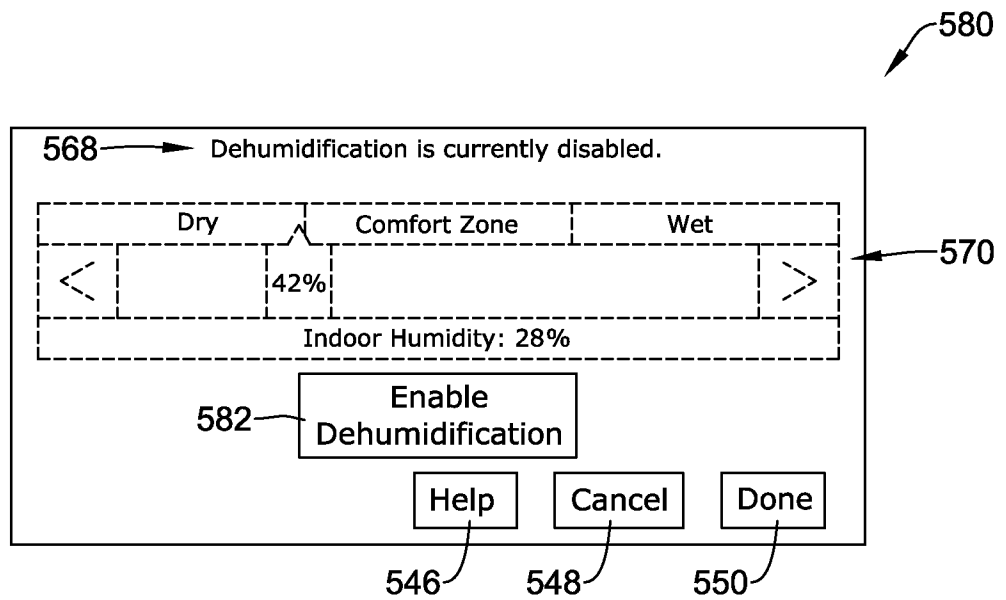

Figure 17

11\13

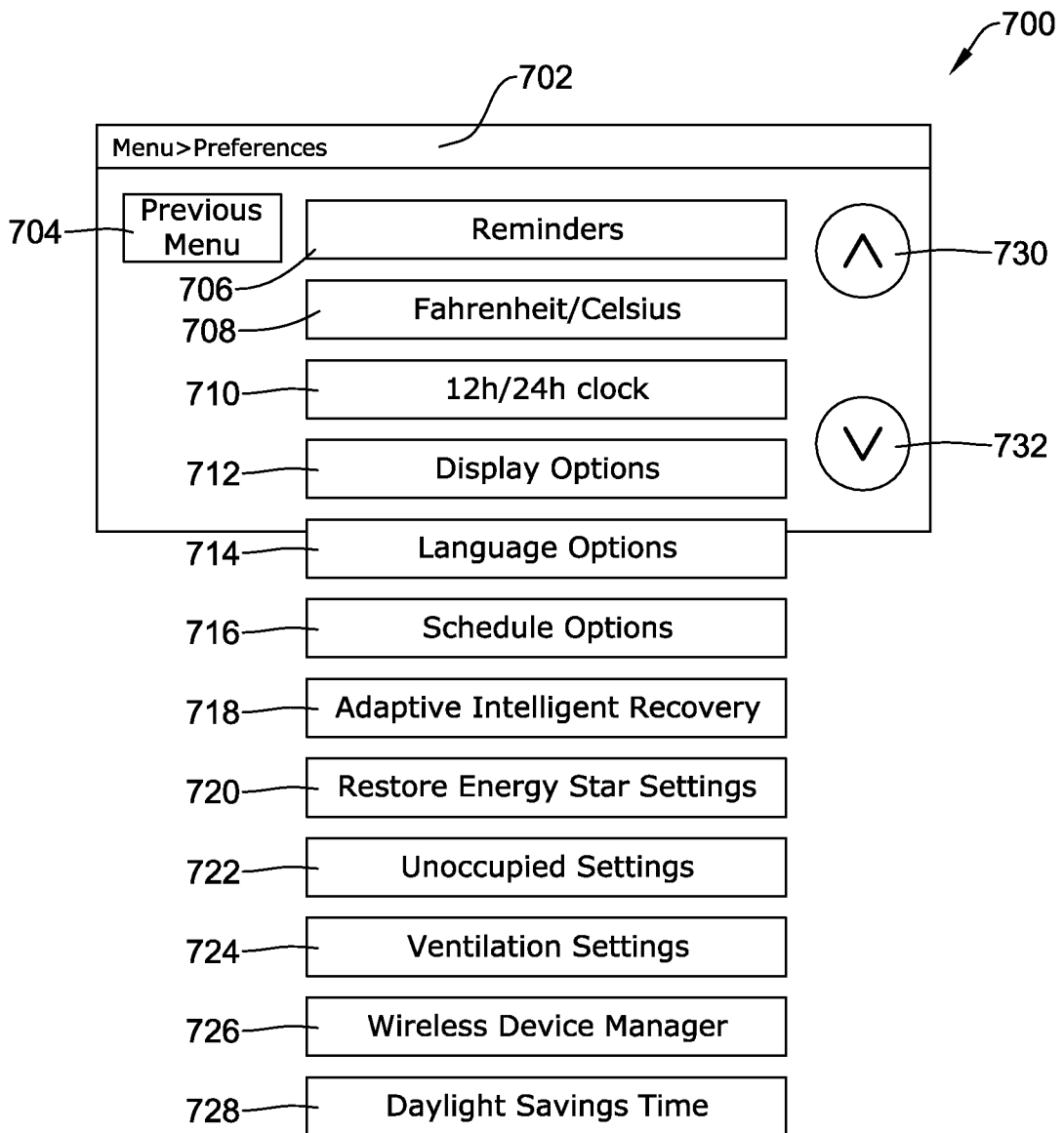

Figure 18

12\13

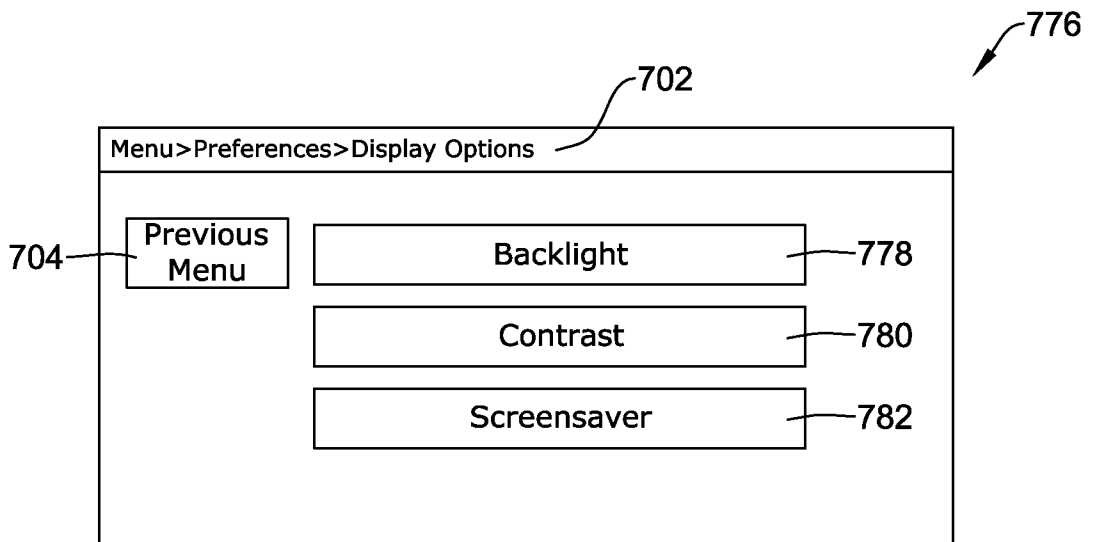

Figure 19

13\13

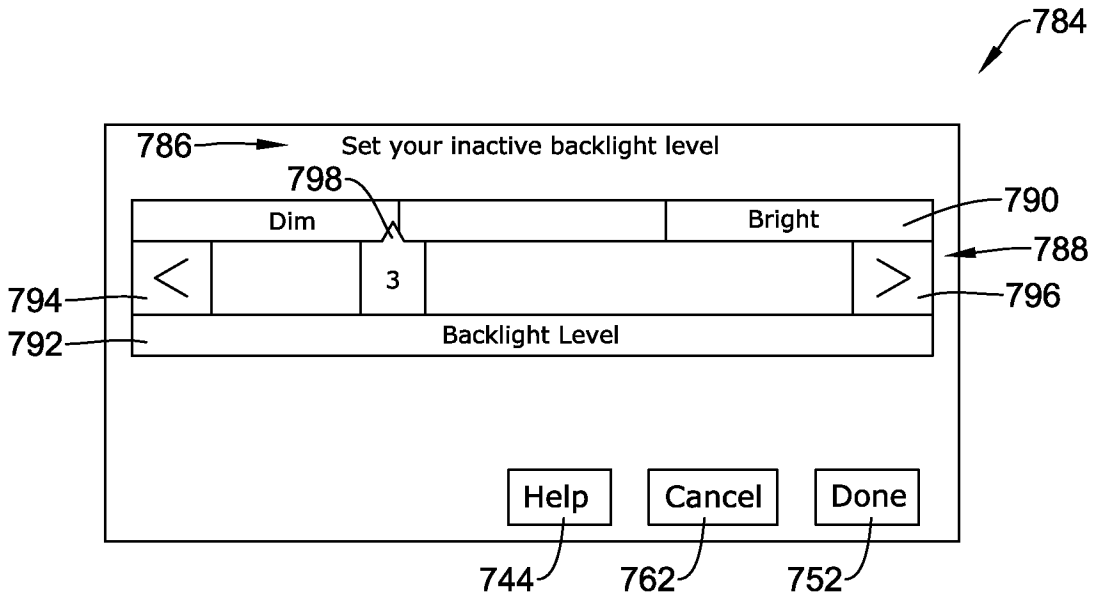

Figure 20

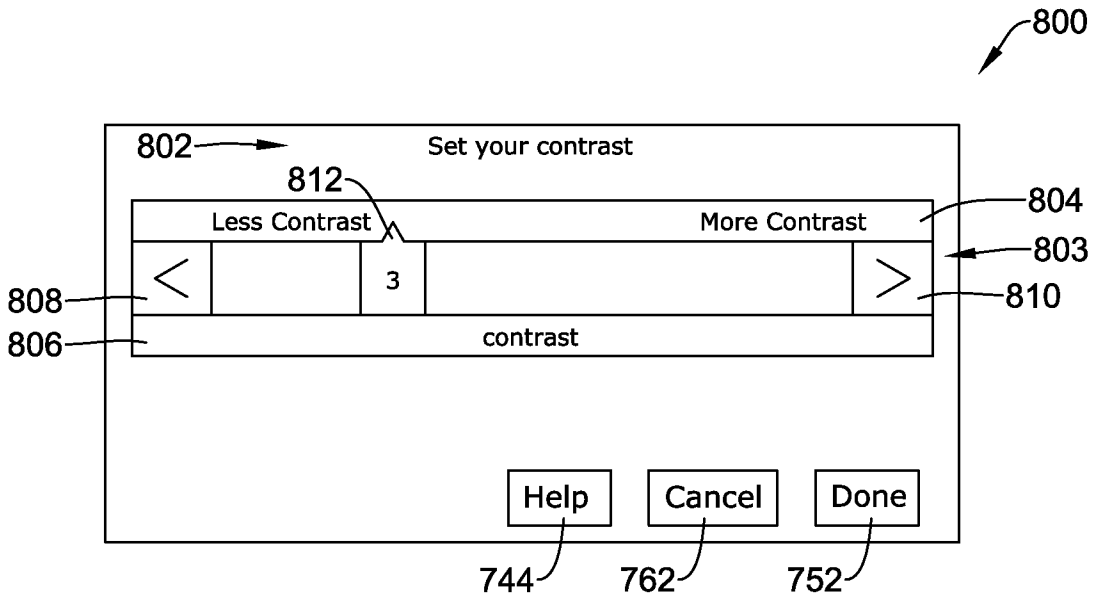

Figure 21