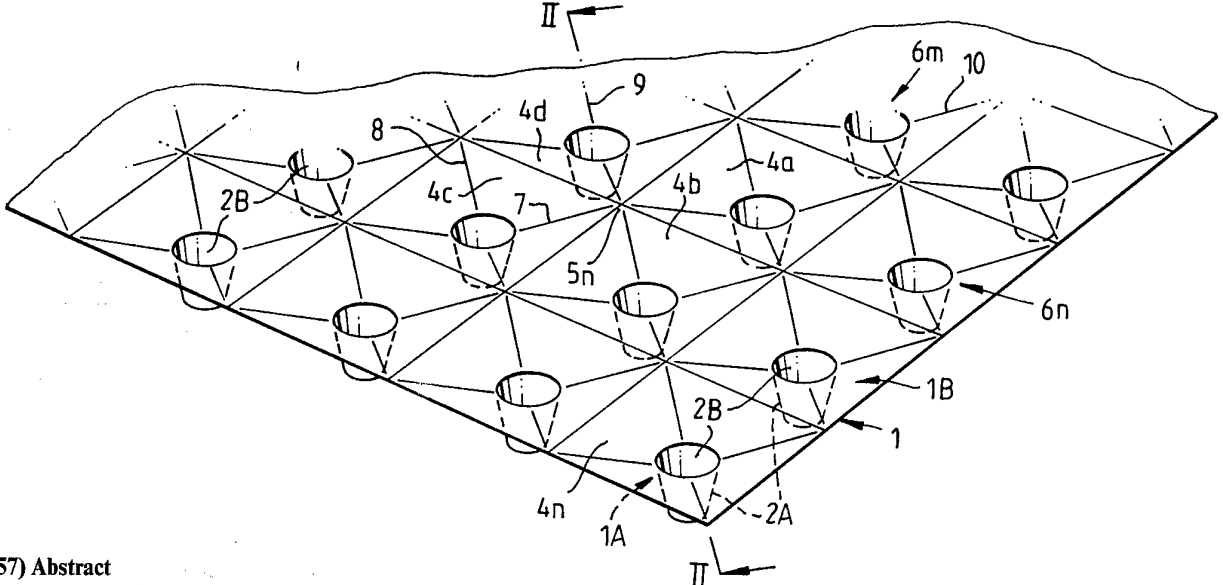

INTERNATIONAL APPLICATION PUBLISHED UNDER THE PATENT COOPERATION TREATY (PCT)

<p>(51) International Patent Classification ⁵ : E04B 5/48</p>	<p>A1</p>	<p>(11) International Publication Number: WO 94/06977 (43) International Publication Date: 31 March 1994 (31.03.94)</p>
<p>(21) International Application Number: PCT/NO93/00125 (22) International Filing Date: 16 August 1993 (16.08.93) (30) Priority data: 923693 23 September 1992 (23.09.92) NO 930392 4 February 1993 (04.02.93) NO (71) Applicant (for all designated States except US): ISOLA AS [NO/NO]; Fabrikk Platon, N-3670 Notodden (NO). (72) Inventor; and (75) Inventor/Applicant (for US only) : MYRVOLD, Egil [NO/NO]; Valhallveien, N-1181 Oslo (NO). (74) Agent: A/S OSLO PATENTKONTOR DR. ING. K.O. BERG; P.O. Box 7007 H, N-0306 Oslo (NO).</p>		<p>(81) Designated States: CA, FI, NO, US, European patent (AT, BE, CH, DE, DK, ES, FR, GB, GR, IE, IT, LU, MC, NL, PT, SE). Published <i>With international search report.</i> <i>In English translation (filed in Norwegian).</i></p>
<p>(54) Title: ARRANGEMENT IN A PROTECTIVE MEMBRANE, ESPECIALLY FOR FLOORS</p>		
		
<p>(57) Abstract</p> <p>The present invention relates to an arrangement in a protective membrane (1; 101; 201), particularly for floors (11; 111; 211), comprising a substantially plane membrane of a preferably rigid material, e.g. plastic or similar, one side of the membrane (1A; 101A; 201A) having a large number of discrete protrusions or knobs (2A; 102A) preferably made by means of moulding, and the other side of the membrane (1B; 101B; 201B) having a corresponding number of indentations (2B; 102B; 202B) with substantially flat areas (4n; 104n) arranged among them and defining the main plane (3; 103) of the membrane, and for the purpose of providing a membrane which demonstrates good ergonomic properties when the floor is used, while at the same time the dampening of the noise of steps is optimized at the lowest possible level, it is suggested according to the invention that the arrangement comprises main area sectors (4n, 5n, 105n) and/or sectors with knobs (205n) which provide a combined yielding effect when subjected to loads and transfer of supporting capacity to other areas of the membrane (2BB; 102BB; 202BB).</p>		

FOR THE PURPOSES OF INFORMATION ONLY

Codes used to identify States party to the PCT on the front pages of pamphlets publishing international applications under the PCT.

AT	Austria	FR	France	MR	Mauritania
AU	Australia	GA	Gabon	MW	Malawi
BB	Barbados	GB	United Kingdom	NE	Niger
BE	Belgium	GN	Guinea	NL	Netherlands
BF	Burkina Faso	GR	Greece	NO	Norway
BG	Bulgaria	HU	Hungary	NZ	New Zealand
BJ	Benin	IE	Ireland	PL	Poland
BR	Brazil	IT	Italy	PT	Portugal
BY	Belarus	JP	Japan	RO	Romania
CA	Canada	KP	Democratic People's Republic of Korea	RU	Russian Federation
CF	Central African Republic	KR	Republic of Korea	SD	Sudan
CG	Congo	KZ	Kazakhstan	SE	Sweden
CH	Switzerland	LI	Liechtenstein	SI	Slovenia
CI	Côte d'Ivoire	LK	Sri Lanka	SK	Slovak Republic
CM	Cameroon	LU	Luxembourg	SN	Senegal
CN	China	LV	Latvia	TD	Chad
CS	Czechoslovakia	MC	Monaco	TC	Togo
CZ	Czech Republic	MG	Madagascar	UA	Ukraine
DE	Germany	ML	Mali	US	United States of America
DK	Denmark	MN	Mongolia	UZ	Uzbekistan
ES	Spain			VN	Viet Nam
FI	Finland				

ARRANGEMENT IN A PROTECTIVE MEMBRANE, ESPECIALLY FOR FLOORS

The Scope of the Invention

The present invention relates to an arrangement in a protective membrane, especially for floors, comprising a substantially plane membrane of a comparatively rigid material, for instance plastic or similar, one side of the membrane having a large number of separated protrusions or knobs, preferably resulting from moulding, and the other side of the membrane having a corresponding number of indentations among which are arranged substantially flat areas which define the main plane of the membrane.

The Background of the invention

The applicant through his developments within the field of protective membranes has provided several generations of the said types of membrane. A first generation of foundation wall membrane is known e.g. from US patent 3 888 087 (Bergsland), while a second generation foundation wall membrane is described in NO patent 148 041, corresponding to CA 1 186 470 (Bergsland).

These protective membranes of first and second generations have mainly been used as foundation wall membranes applied as a cladding to the outer foundation wall of a house before back fill is placed next to it. Such foundation wall membranes are preferably manufactured with knobs which do not readily yield due to the outside forces from e.g. backfilling.

Recently it has also become usual for such foundation wall membranes to be used as a vapour barrier for slab-on-ground, and NO patent application 89 4899, corresponding to US 5.107.642 (Mogstad) describes the use of such membranes for the protection of dwellings from penetration of fluids, especially unpleasant or noxious gases. Similar membranes are also described in applicant's US 5.044.821 (Johnsen).

Available from the applicant are today systems based on the above mentioned protective membranes, particularly for protection from dampness of floors both with and without mechanical ventilation, and especially Norwegian patent application 89 4899 (US 5.107.642) describes a so-called radon solution which preferably uses a protective membrane or a foundation wall membrane with knobs, manufactured in accordance with NO patent 148 041 (CA 1.186.470). (US 3 888 087).

In connection with rehabilitation of basements and in connection with houses with no basements, built on a so-called slab-on-ground, there is a growing demand for a protective membrane on the concrete foundation which may provide the necessary protection, while at the same time constitute part of the applicant's system for mechanical ventilation. Also in connection with the construction of blocks of flats with floors at different levels, it is perhaps often relevant to have such protective membranes next to the untreated floor, especially if it has been levelled with a liquid smoother which emits noxious and/or unpleasant vapours.

In connection with those types of floor, both with regard to basement floors and floors at different levels in blocks of flats, there is, however, a user demand for a finished floor of good ergonomic properties, that is to say that the floor must be comfortable to walk on, and especially where floor dividers in apartment blocks are concerned, there is an increasing demand for particular sound insulating properties in such multi-purpose floors which may be made with or without mechanical ventilation.

Prior art

FI 50 562 relates to a springy floor for sports, exhibition and similar purpose halls where, between a firm base and a floor layer, a springy membrane element is used, having a main plane from which protrusions are projecting in both directions, the individual rows of protrusions having been arranged as bonds or offset relative to each other, and the main plane of the mem-

brane element is arranged so as to be eccentric between the knobs.

Known from DE 2.055.959 is a yielding floor for wet rooms, comprising a floor covering of rubber or plastic which in turn comprises upward directed bulges, while at the same time those areas in contact with the floor itself are secured to said floor by means of anchorage protrusions. This is a very special floor membrane where by definition there are no flat areas arranged between the bulges, but merely narrow transitional areas between the various bulges which are presumably inherently yielding.

DE 3 325 097 also relates to a building element of plastic being used in providing a double floor, comprising a carrier membrane with supporting elements filled with a floor filler. Although this is a matter of a sound-dampening device, very little is said about the floor supposedly yielding.

US 3.888.087 (Bergsland) relates to the applicant's first generation protective membrane and gives no direction for the use of such membranes as intermediate floors, let alone a yielding intermediate floor.

GB 1.222.998 relates to a complex floor comprising a concrete slab 1, on which is arranged an insulation layer which in turn supports a yielding layer made up of corrugated sections of sheets made from hard resin, and a superimposed insulation layer with not quite so pronounced corrugations, as well as a superimposed layer which serves to distribute the pressure, and finally a floor covering on top of everything. The said corrugations are hardly comparable with the present protective membrane where there is a main plane, with knobs or indentations protruding from the main plane, while at the same time the main plane and/or the knobs are made with specifically arranged zone areas which provide for a particularly yielding effect.

NO 148.041 (Bergsland) relates to applicant's second generation of foundation wall membrane, which comprises crater-like knobs

which do not serve a particularly yielding purpose, but rather provide additional support for a possible filter web.

Summarising the Invention

The present invention takes as its basis the task of providing a combination floor in which is used a protective membrane of the nature stated at the outset, which demonstrates ergonomic properties making the floor more comfortable to walk on.

Another objective of the present invention is in such a combination floor, to maintain the volume of air which previous membranes of this nature are able to show.

A further objective of the present invention is to describe a combination floor where the resonance of the sound waves in the volume of air in the protective membrane is optimized with a view to reducing the transmission of noise between floor dividers in multi-storey houses or blocks of flats.

Yet another objective of the present invention is to provide a combination floor in which it should be possible for it, after such a protective membrane has been placed on the untreated floor, to be supported by floor chippings, gyproc (plaster slab) or similar slabs or boards or parquet flooring, while at the same time the membrane is supposed to give a yielding effect or springy effect when the last mentioned is subjected to loads.

According to the invention these aims are achieved by an arrangement in a protective membrane of the nature mentioned initially which is, according to the invention, characterized in that the arrangement comprises main area zones and/or zones with knobs which provide a combined yielding effect when subjected to loads and a transmission of carrying capacity to other areas of the membrane.

A suitable way in which to provide this effect may according to the invention involve that the mainly flat areas which are arranged among the said indentations in the membrane, comprise

or are made up of zones, extending from the main plane and yielding chiefly when subjected to loads. These zones may of course be designed in a number of different ways.

It may e.g. be possible to let the yielding zones comprise zone areas extending at an angle from the main plane and merging into pointed ends between the indentations, or it is possible to make protruding ribs in the otherwise flat areas among the indentations. On a membrane which abuts with its knobs against the untreated floor, the floor membranes may thereafter be placed on the said upwards extending pointed ends or rib-shaped protrusions which will provide suitable yield or springy action when the floor is subjected to loads.

Optionally, the yielding zones may comprise a multitude of individual bulges which are placed at random or incidentally in the area of the substantially flat areas among the cut-outs.

Alternatively, the invention may be realised in that, in the area of the knobs and/or in the knobs themselves, there are arranged areas which, when being subjected to loads, will constitute yielding zones.

Such zones with knobs may be designed in several different ways.

For instance, it has been suggested that the yielding zones are arranged in the root area of one or several knobs.

On a membrane which abuts on an untreated floor, with knobs facing downwards, floor slabs or the utility floor may be placed on the opposite, upper side of the protective membrane, which will provide the appropriate yielding or springy effect when the utility floor is being subjected to loads.

In particular when the protective membrane comprises frustum-conical, hollow knobs, it is appropriate for the yielding zones to be arranged at the root area of each cone, preferably in the form of double-curved zones encircling the root.

In particular, the yielding zones should be designed in such a way as to retain a suitable volume of air in the membrane, while at the same time the resonance of sound waves in the volume of air should give rise to longer sound waves (lower pitch) than formerly known membranes, in order thereby to reduce the transmission of sound between storeys.

Brief Description of the Figures of the Drawings

The invention will be described in the following with reference to exemplified embodiments, taken in conjunction with the attached drawings.

Figure 1 is a perspective view of a section of an initial arrangement in a protective membrane according to the present invention.

Figure 2 is a cross section along the line II-II through the protective membrane shown in Figure 1.

Figure 3 shows on a larger scale a section through a cut-out of the membrane close to an indentation and with a superimposed utility floor not subjected to loads.

Figure 4 is a section similar to Figure 3, but showing the configuration of the section when the superimposed utility floor is subjected to loads.

Figure 5 is a perspective view of a second embodiment of an arrangement in a protective membrane according to the invention.

Figure 6 is a cross section taken along the line IV-IV through the middle parts of the indentations in the membrane as shown in Figure 5.

Figure 7 shows on a larger scale a section through a cut-out of the protective membrane in the area of an indentation, and when the superimposed utility floor is not subjected to loads.

Figure 8 shows a cut similar to Figure 7, but showing the configuration of the membrane when the superimposed utility floor is subjected to loads.

Figure 9 is a perspective view of a cut-out of a third arrangement in a protective membrane according to the present invention.

Figure 10 is a perspective view similar to Figure 9, showing the protective membrane viewed from the other side.

Figures 11 and 12 are on larger scales, sections through a smaller part of the protective membrane shown in Figures 9 and 10, placed on an underlying floor and below supporting floor slabs, in a condition, respectively, of not being and being subjected to loads.

Detailed Description of the Embodiments

In Figures 1 - 4 are illustrated, respectively, a perspective view, a cross section, and two detailed sectors of a protective membrane with pertaining details of a first arrangement in a protective membrane according to the invention. Here, the reference numeral 1 identifies the actual protective membrane, or a sector of the said membrane provided in continuous lengths. The membrane 1 may suitably be made from a comparatively rigid material, e.g. plastic, since this rigidity will entail that the membrane may be manufactured either as sheets of a standardized size, or as a continuous length in a roll.

As will be evident from Figures 1 and 2, from one side of the membrane 1, and indeed the side 1A, a multitude of discrete protrusions or knobs 2A extends, preferably provided by means of moulding, a corresponding number of indentations 2B then being arranged on the other side 1B of the membrane, and among these knobs 2A and/or indentations 2B at the upper part 2BB of the indentations 2B, or correspondingly at the root area 2BB of the knobs 2A, a main plane 3 of the membrane 1 being defined.

According to prior art, in previously known protective membranes as said, the areas 4n which lie between the indentations 2B have been designed as substantially flat areas since it was desirable that the supporting surface be as large as possible relative either to the backfilling which would form a pressure against protective membranes used as foundation wall membranes, or for the superimposed utility floor in those instances where such membranes would be used as system floors, with or without mechanical ventilation.

According to the present invention, however, in order to resolve the tasks from which the present invention takes its basis, in the embodiment shown in Figures 1-4, the said areas 4n have been designed in a general way so as to comprise or be made up of zones or protrusions extending from the main plane 3 and having a yielding effect substantially when subjected to loads.

In the embodiment shown in Figures 1 - 4, the yielding zones 4n comprise zone areas extending at an angle from the main plane 3, particular triangular surfaces 4a - 4d with a shared common apex 5n.

Especially in a membrane 1 with a multitude of indentations 2B arranged in slits 6m and rows 6n at regular intervals, each of the substantially triangular surfaces 4a - 4d has been arranged as curved or more or less interrupted along a line 7 from its base line 8 and to its apex or pointed end 5n. Each of the base lines 8 then continues through an indentation 2B and the apex of this triangle joins other triangles' apexes at the intersection 5n for diagonals, respectively 9 and 10, through corresponding indentations 2A.

In Figure 2 which shows a section through the membrane 1 in Figure 1, and indeed along the line II - II, taken here along the diagonal 9 through the middle portions of the related indentations 2B, it will be seen that compared with what has been defined as the main plane 3 of the membrane, a multitude of pointed ends 5n appear among the knobs 2A or the corresponding indentations 2A. In the normal application of

this type of protective membrane, the membrane 1 will be placed on a floor 11 with the side 2A with the knobs facing downwards towards the floor 11, meaning with the surface of the points 2AA resting against the said floor 11. In Figure 3 which shows a sector of the section according to Figure 2, a utility floor 12 is placed on top of the membrane 1, and when the floor 12 is not subjected to loads, the underside of the utility floor will rest on the said pointed ends 5n, and then at a distance $\Delta 1$ above the main plane 3 of the membrane.

While the floor 12 is being used, that is when subjected to loads P as shown in Figure 4, the protrusions of pointed ends 5n shown of the membrane 1 will provide a springy or yielding action which will be perceived as ergonomically comfortable for anybody using the floor, i.e. the points 5n will yield down to a second distance $\Delta 2$ above the main plane 3 of the membrane.

In a practical embodiment the membrane 1 may have been made with knobs 2A of a height of abt. 6 mm, which means that they extend 6 mm from the main plane 3 of the membrane, while the said protrusions or pointed ends 5n may extend for instance abt. 1 mm from the main plane 3 in the opposite direction of the knobs 2A. When not subjected to loads, as has been illustrated in Figure 3, the points 5n will be in a position abt. 1 mm above the main plane 3, it being understood that the thickness and rigidity of the membrane as such has been adapted so that the utility floor 12 may be supported without any noticeable lowering of the points 5n. Then, in the state of not being subjected to loads, an angle $\alpha 1$ will result between the main plane 3 and the zone areas 4a - 4d extending at an angle from the main plane 3, while, in a state of being subjected to loads, as is illustrated in Figure 4, a considerably smaller angle $\alpha 2$ will result between the main plane 3 and the said points 5n affected in this connection, because of the yield or springy action to which the said extending zone areas 4a - 4d which yield when being subjected to loads, give rise.

In Figures 5 - 8 which show a second embodiment of an arrangement in a protective membrane according to the

invention, the membrane 101 has also here been made with protrusions or knobs 102A on one side of the membrane 101A, these protrusions defining corresponding indentations 102B in the other side 101B of the membrane, and, among the said indentations 102B or knobs 101A, substantially flat areas 104n being arranged which define the main plane 103 of the membrane.

In the embodiment shown in Figures 5 - 8, the substantially flat areas 104n have been made with yielding zones, comprising ribs 105n extending from the main plane 103 of the membrane, these in the present embodiment having been made in a pattern of squares or a random pattern of netting intersecting among the indentations 102B.

In Figures 6 and 7 is shown how the present membrane 101 has been placed on an untreated floor 111 with the upper areas 102AA of its knobs 102A resting against the floor, while it is shown in Figure 7 that the membrane 101 on its ribs 105n extending in the opposite direction from the floor 111 supports a utility floor 122 not subjected to loads, and indeed a distance of $\Delta 101$ above the main plane 103 of the membrane.

At the section shown in Figure 8, the utility floor 12 has been subjected to a load P, and the yielding ribs 105n, together with the surrounding flat areas 104n, have then yielded or acted as springs down towards the level of the floor 111, shown here as a shorter distance $\Delta 102$ above the main plane 103 of the membrane, in order thereby to convey to the user of the floor a springy effect which makes the floor more comfortable to walk on.

Also in this embodiment the height of the knobs can preferably be abt. 6 mm, while the height of the ribs 105n may suitably be abt. 1 mm, but these dimensions may naturally be varied within wide ranges, depending on the yield or springy action desired when subjecting to loads the floor 112 which is placed on the membrane 101.

From the Figure 9-12 will be seen a third embodiment of the present invention which concerns an arrangement in the

protective membrane 201, especially for floor 211. Here, too, the membrane comprises a substantially level membrane 201 of a preferably rigid material, e.g. plastic or such like, one side 201A of the membrane having a large number of discrete protrusions or knobs 202A, preferably made by moulding, and the other side of the membrane 201B having a corresponding number of indentations 202B with substantially flat areas 204n arranged among them and defining the main plane 203 of the membrane. The membrane 201 is distinguished in that in the areas of the knobs 202A and/or in the knobs themselves, sectors 205n are arranged which, when being subjected to loads, will constitute yielding zones.

It is furthermore evident particularly from Figures 11 and 12 that the yielding zones 205n are arranged in the root area 202AA of one or several knobs 202A, that the yielding zones are arranged as at least one continuous part-torus or as convex sectors round the root area 202AA of one or several knobs 202A. More particularly, the yielding zones are arranged at the root area 202AA of each cone, preferably designed as double-curved zones 205 encircling the root, the root-encircling zones 205 comprising in cross-section an initial outer ring-shaped surface 205A extending beyond the main plane 203 of the membrane and continuing in a curved sector and thus curving inwards towards the centerline C of the knob concerned and into a surface 205B extending back towards the main plane and in turn curving towards and continuing into the upper edge 202BB of the actual indentation 202B, and then a dimension $\Delta 201$ from the main plane 203 without being subjected to loads, the said dimension being reduced to $\Delta 202$ or less when being subjected to the load P on the utility floor 212.

It should be understood that the area 205A extending beyond the main plane may pass across the upper edge of the indentation or in the root area of the knob 202A itself at a distance $\Delta 201$ from the main plane 203 via one or several additional suitable winding ring-shaped surfaces, e.g. in that parts of one or several knobs are designed with yielding sectors lying as bellows. Also in such embodiments, when subjecting the floor to loads, the result achieved will be that the supporting

capacity of the membrane will be transferred to other surface areas, for instance down to the root edges 202BB, the main plane 203 of the membrane, see fig. 11, descending via the position 203, see fig. 12.

The yielding zones are also here adapted in such a way, particularly in relation to the design of the knobs, that the optimal dampening of steps is achieved when the membrane is placed between an untreated floor and a utility floor, particularly in providing resonance sound waves of longer wavelengths and lower pitch.

In the present invention special arrangements in protective membranes have thus been provided, and it should in particular be understood that the said yielding zones may also be varied within wide limits. For instance, the yielding zones may comprise a multitude of individual bulges, placed at random or incidentally in the area of the flat surfaces which lie among the said indentations 2B or 102B and/or comprise sectors of the actual indentations 202B.

It shall furthermore be understood that the membrane may be manufactured from many different materials, and a preferred plastic may be high density polyethylene of a density of minimum 950 kg/m^2 and a max. melt flow index of 0.3 g/10 minutes . Preferably, such a product may be resistant to UV decomposition, to alkalis and thermo oxidising decomposition. As an alternative to an all black membrane, for instance a membrane of a natural colour may be used, or a black membrane with a natural flap.

One advantage of a natural coloured membrane is that after the laying thereof, it is possible to check the seams in the best possible way while at the same time it may be possible to check whether the underlying concrete slab or untreated floor has been cleaned. In the event that a natural coloured membrane is used, the product should be UV stabilised in order to meet any specifications required by the building regulations in various countries.

Furthermore it shall be understood that the shape, the height, diameter and interpositioning of the knobs will need to be considered with regard to static and dynamic loads, and also the amount of air in the slits between the knobs, the flow pattern in mechanical ventilation as well as under-pressure in the said slits.

It should be understood that, in principle, any form of knobs may be used, meaning both simple knobs in the shape of a truncated round or multi-sided cone or in the form of round "double knobs". The height of the knobs and the shape of the knobs should be adapted in relation to the required volume of air and with a view to not causing a deterioration of the properties of corresponding membranes in terms of air noise insulation. At the same time the intention should be to design the knobs and their positions in such a way as to provide resonance for longer sound waves (lower pitch) than in knob shapes of the present nature since this will be of significance to the transmission of sound through floor dividers.

Ideally, the diameter/circumference of the cones should be as small as possible, and endeavours should be made to have the wall of the cone as straight as possible, but this should be evaluated against methods for manufacturing the membrane in a rational manner, particularly with regard to the possibility of moulding and not least the supporting capacity of the knobs as such. The knobs should preferably be placed in a symmetrical pattern so that they fit into each other when sideways mounting is carried out in the lengthwise and transverse directions. The intervals between knobs should be optimized and should be as large as possible all being calculated with account taken of the resistance to pressure, static and dynamic loads in the mounted state, and well as the load from transport on the membrane during mounting. The dimension and the shape of the knobs will moreover interact with the intervals between knobs where the capacity of the membrane to resist loads is concerned.

In the present invention, and as shown in the specific embodiments, and "ergonomic" protective membrane has been

provided in which are arranged main area sectors and/or knob sectors which when being subjected to dynamic loads will allow themselves to be depressed, while yielding, down to a second level of the main plane of the membrane, so that at full yield in the elastic zones, the supporting capacity of the membrane will be transferred to other areas of the membrane.

When the load is removed from the floor, it shall be understood that the elastic areas return substantially to their main shape.

In the embodiments shown which show, respectively, rectangular protrusions in the areas between the root of the knob and rib-shaped protrusions which form a netting pattern, as well as knobs with yielding zones, it is shown in the various drawings how the depressed area varies between a floor not subjected to loads and one which is subjected to loads. It shall be understood that this depressed area may of course be varied, depending on the dimensions chosen which should naturally be optimized according to prevailing conditions and the terms and requirements stipulated.

The present arrangement in a protective membrane thus describes a solution which to a considerable degree improve the ergonomic properties in utility floors while at the same time an optimization is achieved of the transmission of sound through floors incorporating the said protective membranes according to the invention.

P a t e n t C l a i m s

1. An arrangement in a protective membrane (1; 101; 201), particularly for floors (11; 111; 211), comprising a substantially plane membrane of a preferably rigid material, e.g. plastic or such like, one side (1A; 101A; 201A) of the membrane having a large number of discrete protrusions or knobs (2A; 102A; 202A) preferably made by means of moulding, and the other side of the membrane (1B; 101B; 201B) having a corresponding number of indentations (2B; 102B; 202B) with substantially flat areas (4n; 104n; 204n) arranged among them which define the main plane of the membrane (3; 103; 203), characterized in that the arrangement comprises the main flat areas 4n, 5n, 105n) and/or the areas (205n) with knobs which give a combined yielding effect when being subjected to loads and transfer of supporting capacity to other areas (2BB; 102BB; 202BB) of the membrane.

2. An arrangement as stated in claim 1 characterized in that the substantially flat areas arranged among the indentations (2B; 102B) comprise or are made up of zones (4n, 5n; 105n) substantially yielding when subjected to loads and protruding from the main plane (3; 103).

3. An arrangement as stated in claim 1 or 2, characterized in that the yielding zones comprise zone surfaces (4a-4d) extending at an angle from the main plane (3) being e.g. substantially triangular surfaces with a common highest apex (5n).

4. An arrangement as stated in claim 3, in particular for a membrane (1) with a multitude of indentations (2B) arranged in slits (6m) and rows (6n) at regular intervals, characterized in that each of the substantially triangular surfaces (4a - 4d) is curved or more or less interrupted along a line (7) from its base line (8) towards the apex (5n), the base line (8) continuing through an indentation

(2B) and the apex (5n) to join other triangles' apexes at the intersection for diagonals (9, 10) through indentations (2B).

5. An arrangement as stated in claim 1, characterized in that the yielding zones (104n) arranged as main area surfaces comprise ribs (105n) protruding from the main plane (103) of the membrane (101).

6. An arrangement as stated in claim 5, characterized in that the ribs (105n) have been made as a pattern of squares (fig. 5) or a random pattern of netting intersecting between the indentations (102B)

7. An arrangement as stated in one of the preceding claims, characterized in that the yielding areas or zones comprise a multitude of individual bulges, placed at random or incidentally in the area of the substantially flat parts of the membrane.

8. An arrangement as stated in claim 1, characterized in that in the area of the knobs (202A), and/or in the knobs themselves, sectors (205n) are arranged which constitute yielding zones when subjected to loads.

9. An arrangement as stated in claim 1 or 8, characterized in that the yielding zones (205n) are arranged in the root area (202AA) of one or several knobs (202A).

10. An arrangement as stated in claim 1, 8 or 9, characterized in that the yielding zones are arranged as one part-torus or as convex parties encircling the root area (202AA) of one or several knobs (202A).

11. An arrangement as stated in claim 8, particularly comprising frustum-conical hollow knobs (202A) characterized in that the yielding zones are arranged at the root area (202AA) of each individual cone, preferably made as double-curved, root-encircling zones (205).

12. An arrangement as stated in claim 11, characterized in that the root-encircling zones (205) in cross-section comprise an initial outer ring-shaped area (205A) extending beyond the main plane of the membrane and curving inwards towards the centerline (C) of the knob concerned and into a surface (205B) extending back towards the main plane and in turn curving towards and continuing into the root area of the actual knob at a distance ($\Delta 1$) from the main plane (203).

13. An arrangement as stated in claim 12, characterized in that the area (205A) extending beyond the main plane continues into the root area of the actual knob at a distance ($\Delta 1$) from the main plane (203) via one or several additional, suitably winding ring-shaped surfaces.

14. An arrangement as stated in claim 11, characterized in that parts of one or several knobs are designed with yielding sectors resembling bellows.

15. An arrangement as stated in any of the preceding claims characterized in that the yielding zones are adapted in such a way, especially in relation to the design of the knobs, as to achieve optimal dampening of the sound of steps when the membrane is placed between an untreated floor and a utility floor, particularly in providing resonance sound waves of longer wavelengths and lower pitch.

16. Application of an arrangement as stated in any of the preceding claims, particularly for floors, as a combined dampness/vapour protective membrane, ventilation membrane and sound insulating/ergonomic intermediate floor.

17. Application of a protective membrane as stated in any of the preceding claims, particularly for floors, mounted with its protrusions or its knobs downwards against an untreated floor and with the yielding zones (protrusions) upwards from the

untreated floor for the support of a floor covering (floor chippings, plaster slabs, parquet flooring or similar).

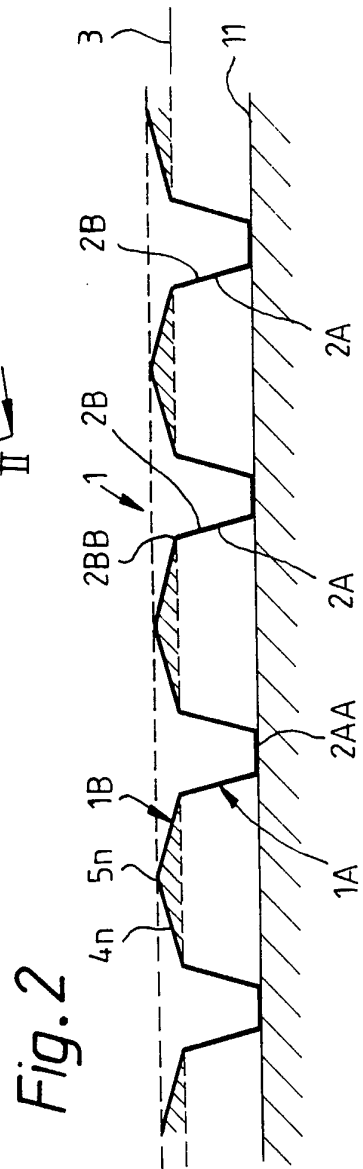
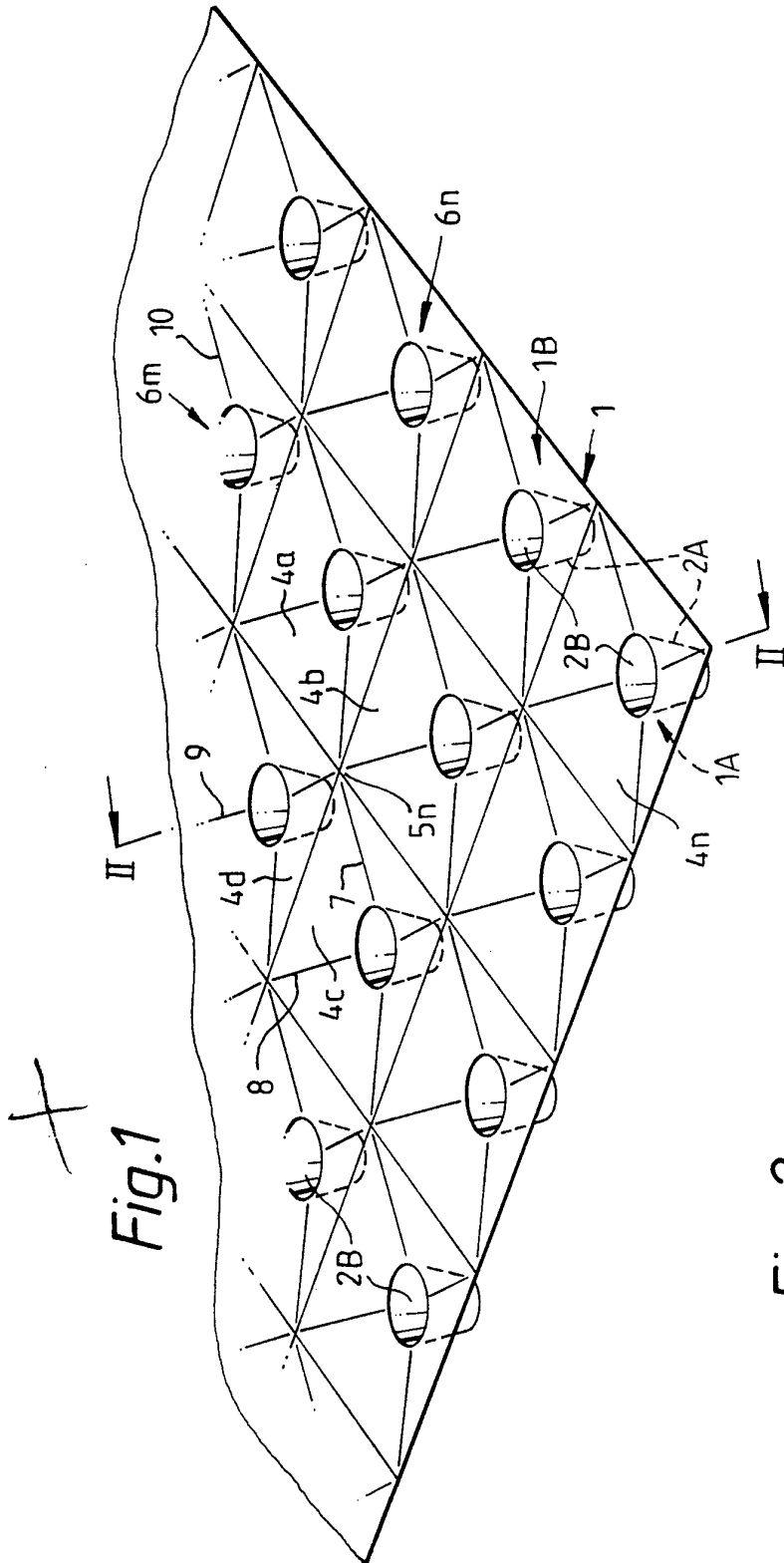

Fig.3

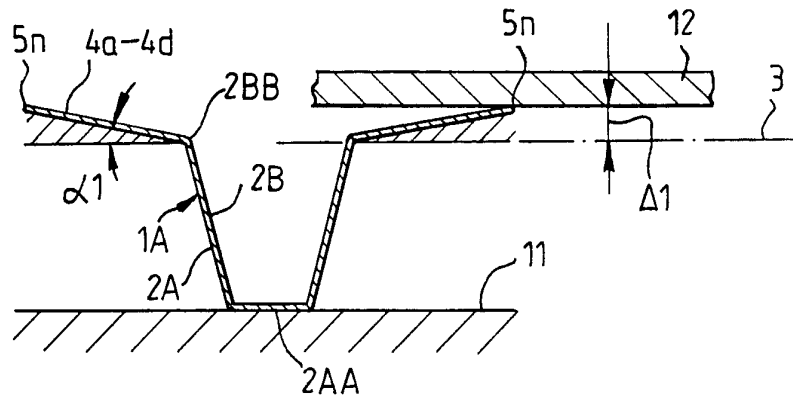

Fig.4

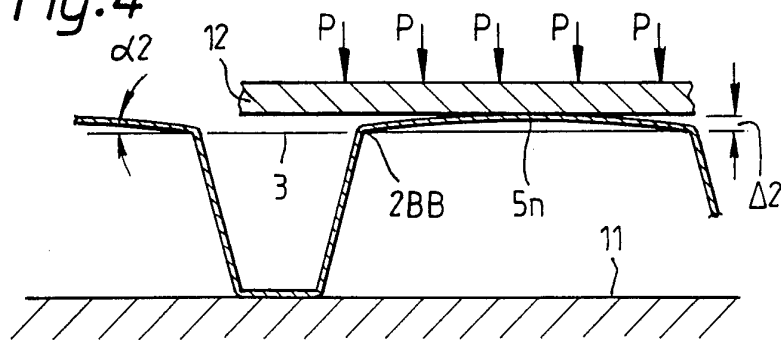

Fig. 7

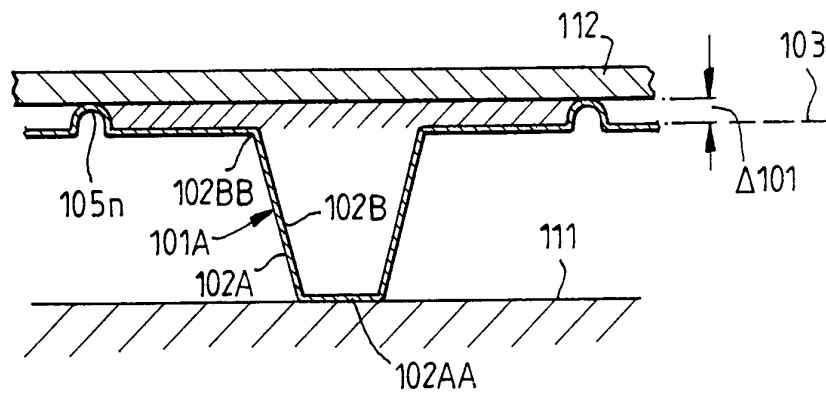
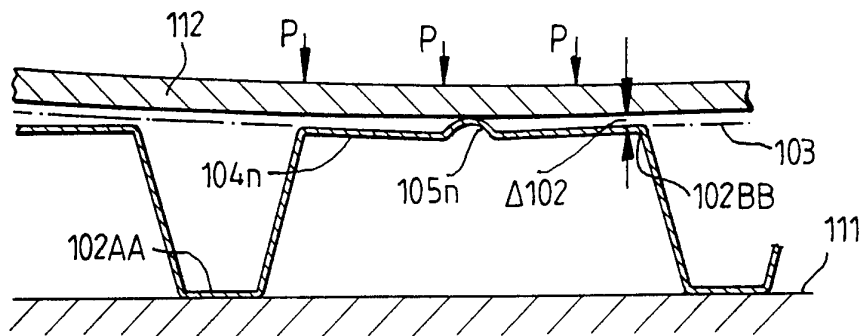

Fig. 8



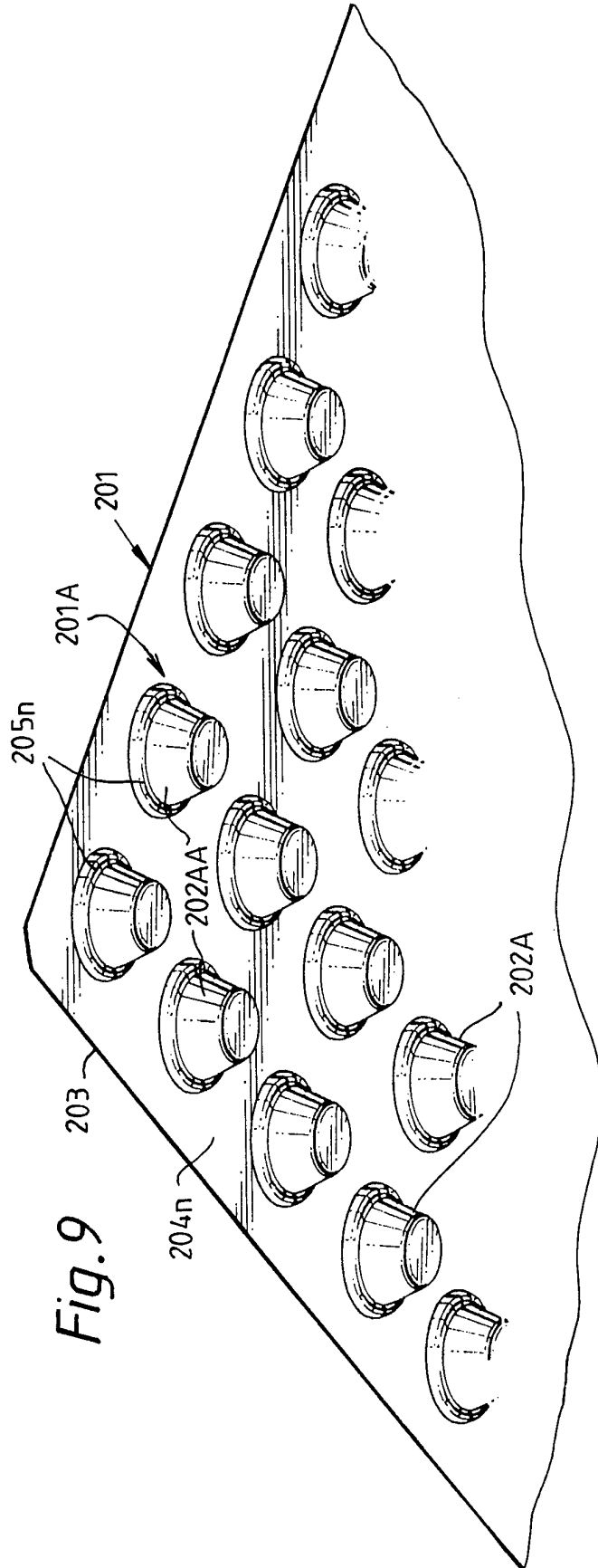

Fig. 9

Fig.10

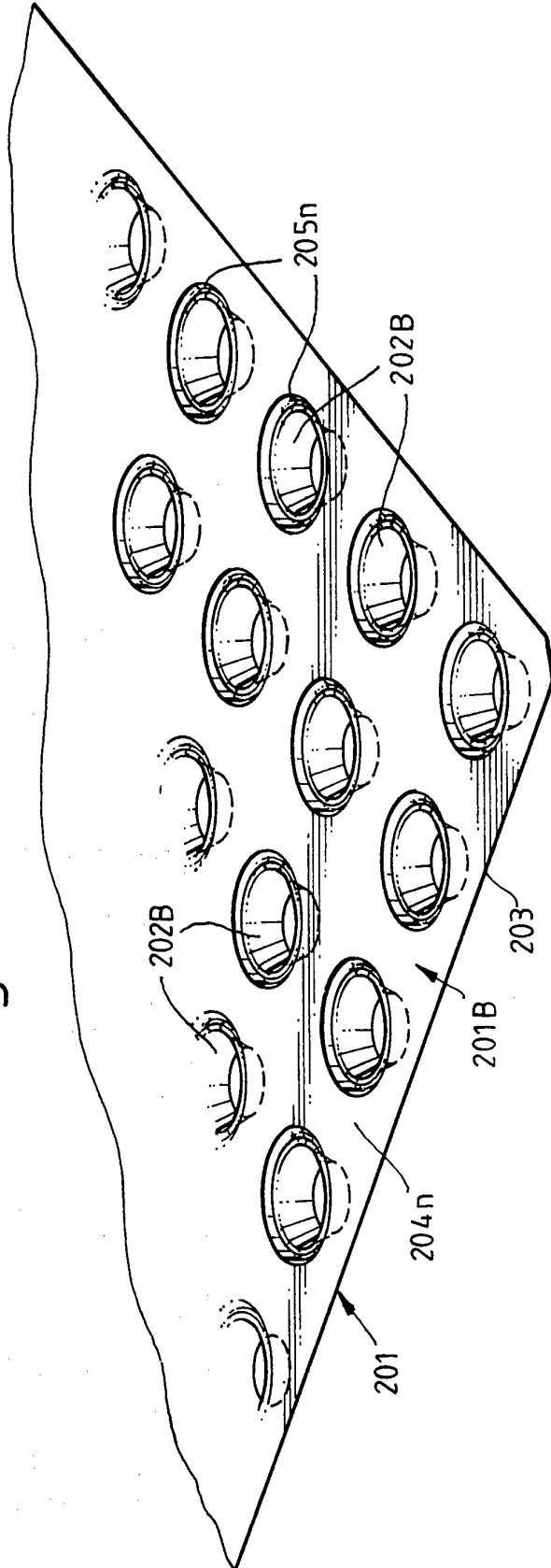

Fig.12

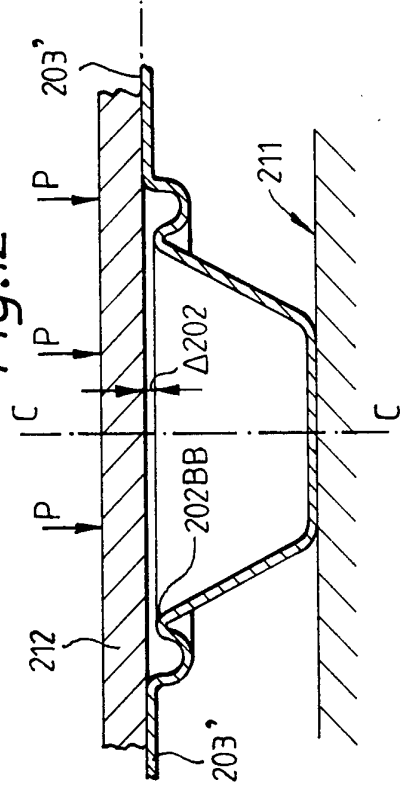
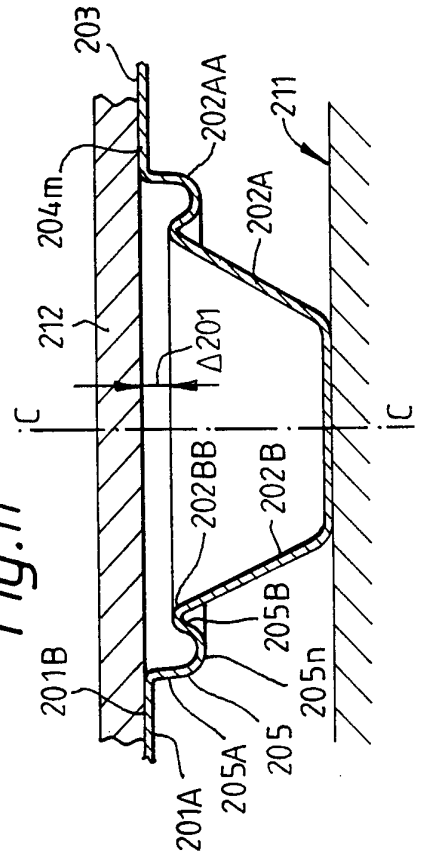

Fig.11



INTERNATIONAL SEARCH REPORT

International application No.
PCT/NO 93/00125

A. CLASSIFICATION OF SUBJECT MATTER		
IPC5: E04B 5/48 According to International Patent Classification (IPC) or to both national classification and IPC		
B. FIELDS SEARCHED		
Minimum documentation searched (classification system followed by classification symbols)		
IPC5: E02D, E04B, E04F		
Documentation searched other than minimum documentation to the extent that such documents are included in the fields searched		
SE,DK,FI,NO classes as above		
Electronic data base consulted during the international search (name of data base and, where practicable, search terms used)		
C. DOCUMENTS CONSIDERED TO BE RELEVANT		
Category*	Citation of document, with indication, where appropriate, of the relevant passages	Relevant to claim No.
X	SE, A, 7514385 (NOKIA OY AB), 19 June 1976 (19.06.76), the whole document	1,2,7
Y	the whole document	8,9,11,16,17
A	figure 1	10
	--	
X	US, A, 5052161 (D.C. WHITACRE), 1 October 1991 (01.10.91), figures 4-6	1,2,9
	--	
Y	GB, A, 1122998 (FORSHAGA AKTIEBOLAG), 7 August 1968 (07.08.68), page 1, line 33 - line 37; page 2, line 4 - line 7; page 2, line 22 - line 28	8,9,16,17
	--	
<input checked="" type="checkbox"/> Further documents are listed in the continuation of Box C. <input checked="" type="checkbox"/> See patent family annex.		
* Special categories of cited documents: "A" document defining the general state of the art which is not considered to be of particular relevance "E" earlier document but published on or after the international filing date "L" document which may throw doubts on priority claim(s) or which is cited to establish the publication date of another citation or other special reason (as specified) "O" document referring to an oral disclosure, use, exhibition or other means "P" document published prior to the international filing date but later than the priority date claimed "T" later document published after the international filing date or priority date and not in conflict with the application but cited to understand the principle or theory underlying the invention "X" document of particular relevance: the claimed invention cannot be considered novel or cannot be considered to involve an inventive step when the document is taken alone "Y" document of particular relevance: the claimed invention cannot be considered to involve an inventive step when the document is combined with one or more other such documents, such combination being obvious to a person skilled in the art "&" document member of the same patent family		
Date of the actual completion of the international search		Date of mailing of the international search report
21 December 1993		29 -12- 1993
Name and mailing address of the ISA/ Swedish Patent Office Box 5055, S-102 42 STOCKHOLM Facsimile No. +46 8 666 02 86		Authorized officer Jan Thorstensson Telephone No. +46 8 782 25 00

INTERNATIONAL SEARCH REPORT

International application No.

PCT/NO 93/00125

C (Continuation). DOCUMENTS CONSIDERED TO BE RELEVANT		
Category*	Citation of document, with indication, where appropriate, of the relevant passages	Relevant to claim No.
Y	NO, C, 111836 (A/S PLATON), 6 November 1967 (06.11.67), figure 4 --	11
Y	NO, C, 148041 (A/S PLATON), 18 April 1983 (18.04.83), abstract	17
A	--	1,2
A	WO, A1, 9304238 (SIEBER, W.), 4 March 1993 (04.03.93), page 2, line 12 - line 14 --	1,2,7,17
A	DE, A1, 3325907 (BAUER, E.), 17 February 1985 (17.02.85), the whole document -- -----	1,2,5,6

INTERNATIONAL SEARCH REPORT

International application No.

PCT/NO 93/00125

Box I Observations where certain claims were found unsearchable (Continuation of item 1 of first sheet)

This international search report has not been established in respect of certain claims under Article 17(2)(a) for the following reasons:

1. Claims Nos.:
because they relate to subject matter not required to be searched by this Authority, namely:

2. Claims Nos.: 15
because they relate to parts of the international application that do not comply with the prescribed requirements to such an extent that no meaningful international search can be carried out, specifically:

The presentation of the problem of achieving optimal sound insulation of the hollow floor as contained in claim 15 does not alone imply a means for the solution of the problem. The means for solving the problem has therefore to be specified in the claim see also Article 17(2)(a).
3. Claims Nos.:
because they are dependent claims and are not drafted in accordance with the second and third sentences of Rule 6.4(a).

Box II Observations where unity of invention is lacking (Continuation of item 2 of first sheet)

This International Searching Authority found multiple inventions in this international application, as follows:

1. As all required additional search fees were timely paid by the applicant, this international search report covers all searchable claims.
2. As all searchable claims could be searched without effort justifying an additional fee, this Authority did not invite payment of any additional fee.
3. As only some of the required additional search fees were timely paid by the applicant, this international search report covers only those claims for which fees were paid, specifically claims Nos.:
4. No required additional search fees were timely paid by the applicant. Consequently, this international search report is restricted to the invention first mentioned in the claims; it is covered by claims Nos.:

Remark on Protest

- The additional search fees were accompanied by the applicant's protest.
- No protest accompanied the payment of additional search fees.

INTERNATIONAL SEARCH REPORT
Information on patent family members

27/11/93

International application No.
PCT/NO 93/00125

Patent document cited in search report	Publication date	Patent family member(s)	Publication date
SE-A- 7514385	19/06/76	NONE	
US-A- 5052161	01/10/91	US-A- 5255482	26/10/93
GB-A- 1122998	07/08/68	BE-A- 670735 NL-A- 6513045	31/01/66 12/04/66
NO-C- 111836	06/11/67	NONE	
NO-C- 148041	18/04/83	NONE	
WO-A1- 9304238	04/03/93	EP-A- 0552162	28/07/93
DE-A1- 3325907	17/02/85	NONE	