



US 20090242589A1

(19) **United States**

(12) **Patent Application Publication**
Berthelin et al.

(10) **Pub. No.: US 2009/0242589 A1**

(43) **Pub. Date: Oct. 1, 2009**

(54) **CLOSURE FOR A CONTAINER CONTAINING A FLUID**

(30) **Foreign Application Priority Data**

Nov. 3, 2006 (FR) 0654726

(75) Inventors: **Frederic Berthelin, Meaux (FR);
Etienne Lemasle, Paris (FR)**

Publication Classification

(51) **Int. Cl.**
B65D 25/38 (2006.01)
B65D 41/04 (2006.01)

Correspondence Address:
**WOOD, PHILLIPS, KATZ, CLARK & MOR-
TIMER**
500 W. MADISON STREET, SUITE 3800
CHICAGO, IL 60661 (US)

(52) **U.S. Cl.** **222/494; 220/288**

(57) **ABSTRACT**

The present invention relates to a closure or cap for a container containing a fluid. The closure or cap is characterized in that the slotted structure comprises several pivoting plates hinged to the body in such a way as to be able to pivot; at least one pivoting plate, preferably each pivoting plate, being connected movably to a neighbouring pivoting plate via a cross section of more flexible deformation than the several pivoting plates, which forms one of the free terminal edges of the slot or slots and is, in a condition of actuation without overpressure inside the container, arranged basically contiguously with the other free terminal edge situated opposite the slot or slots and can open by pivoting away from the inside of the container when the fluid generates increased pressure inside the container, whereupon it moves away from the other free terminal edge.

(73) Assignees: **., Seaquist Closures France
S.A.S., Poigny (FR)**

(21) Appl. No.: **12/443,370**

(22) PCT Filed: **Nov. 2, 2007**

(86) PCT No.: **PCT/EP07/09537**

§ 371 (c)(1),
(2), (4) Date: **Mar. 27, 2009**

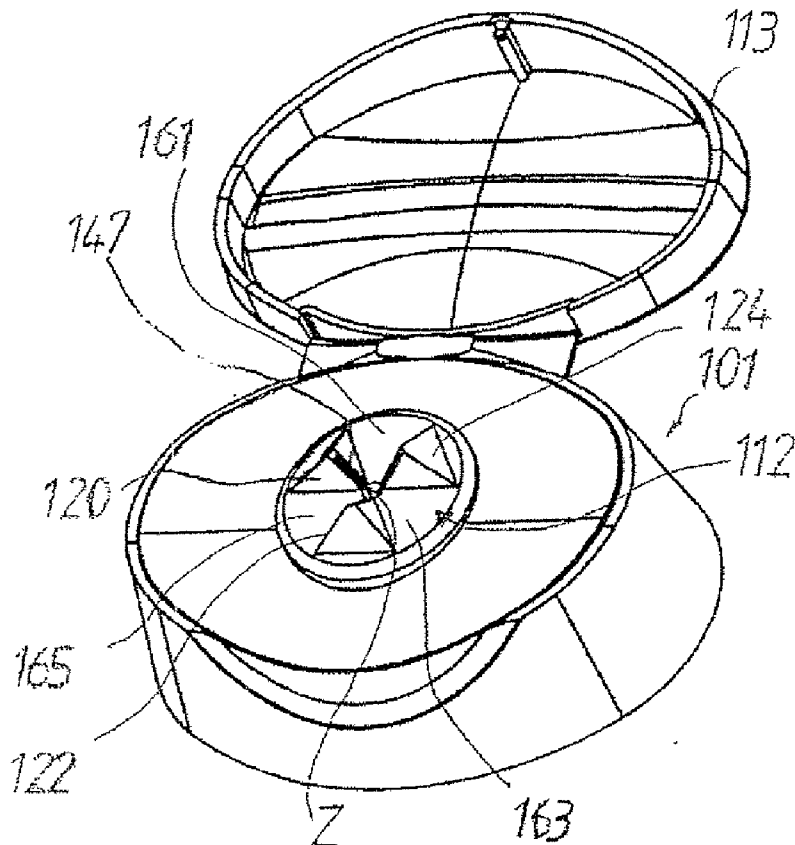

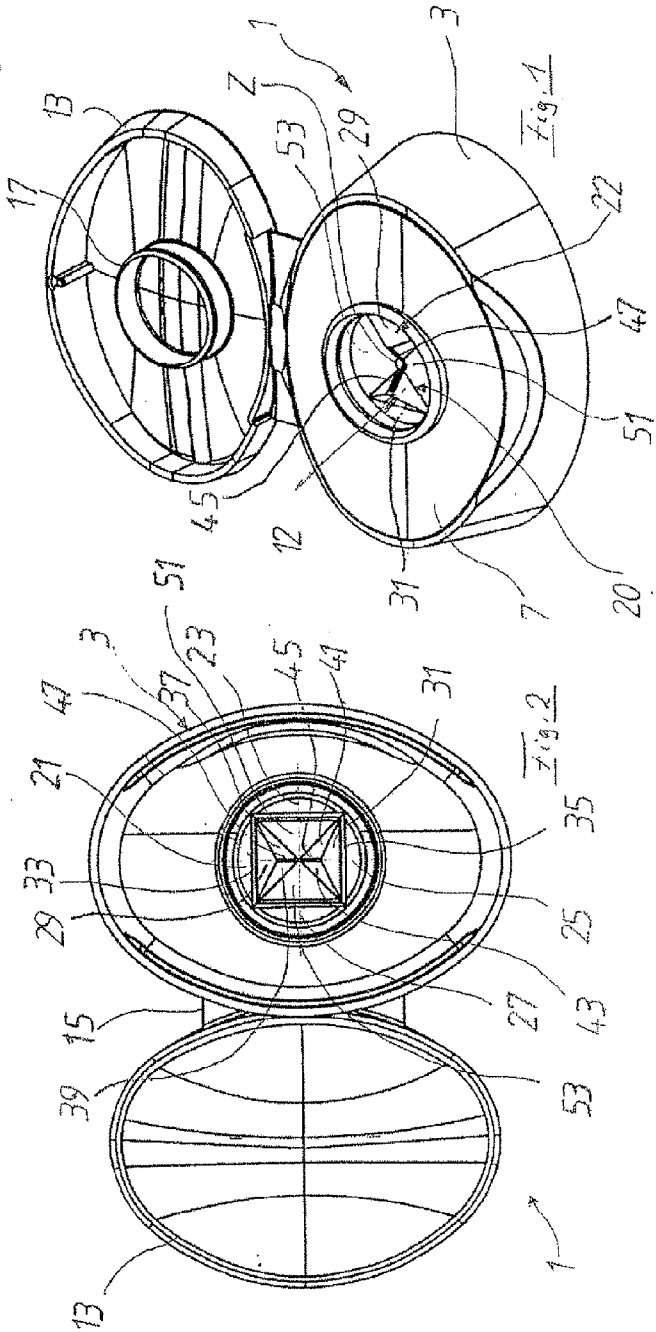
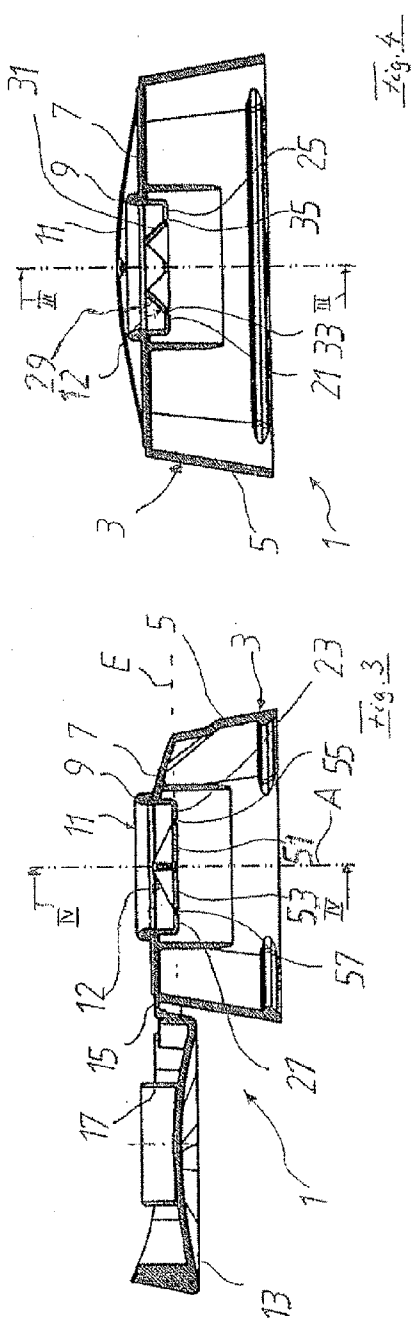

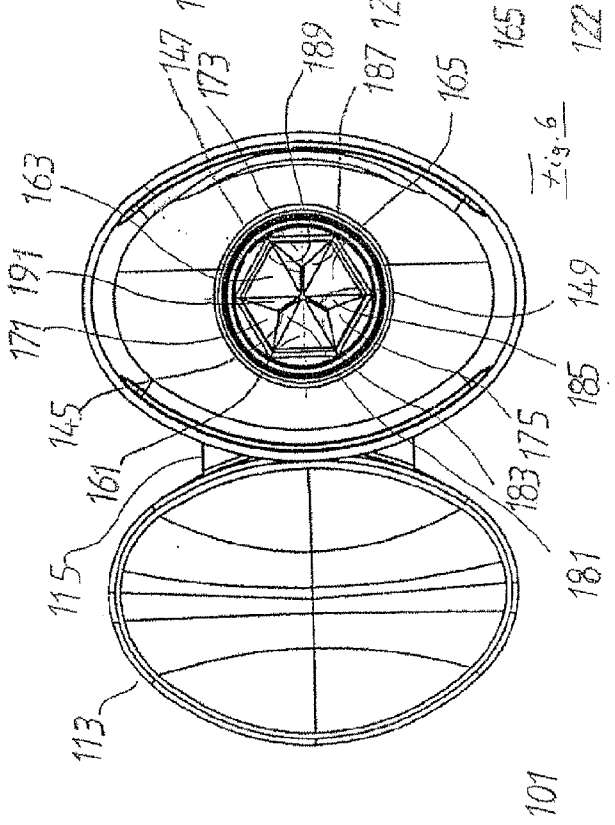
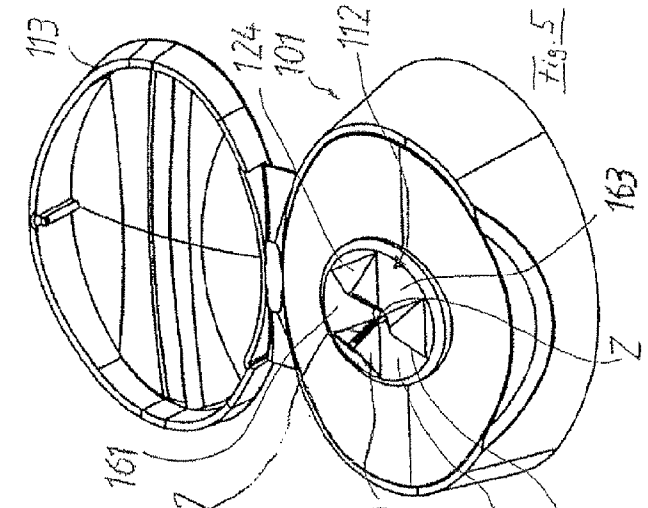
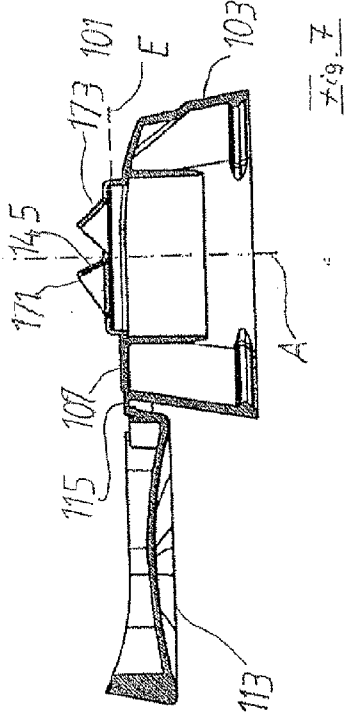
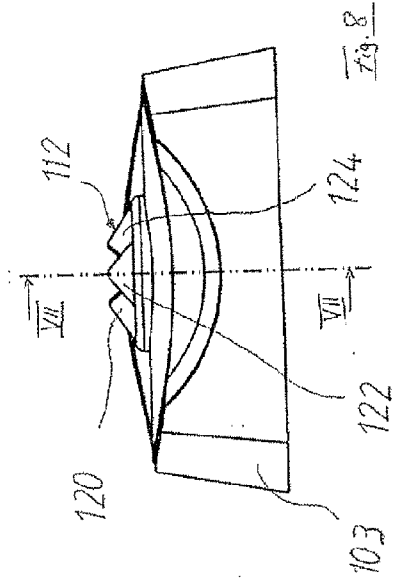

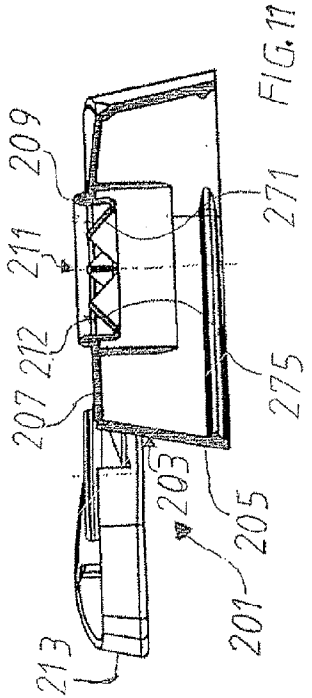

FIG. 10

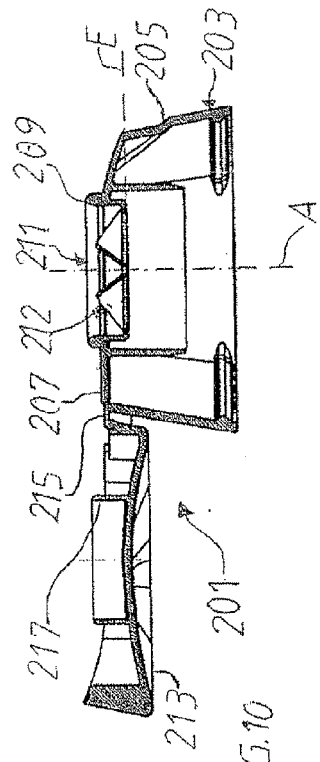

FIG. 11

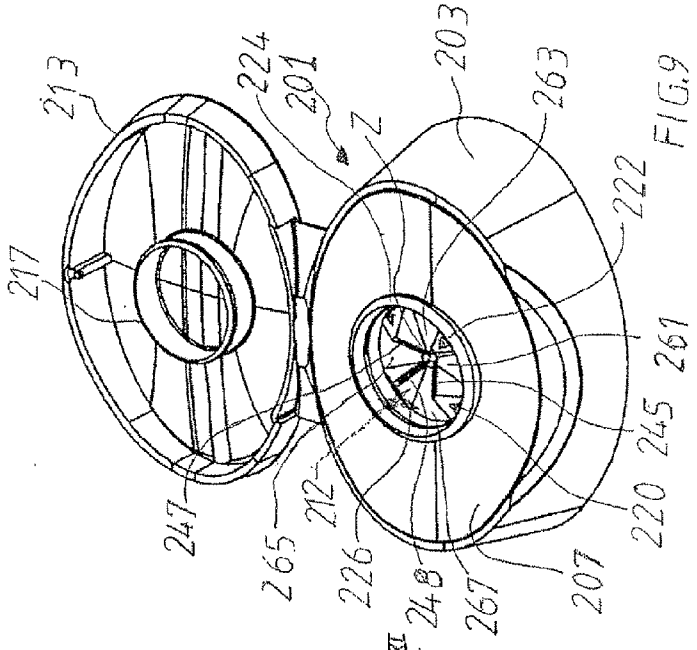

FIG. 9

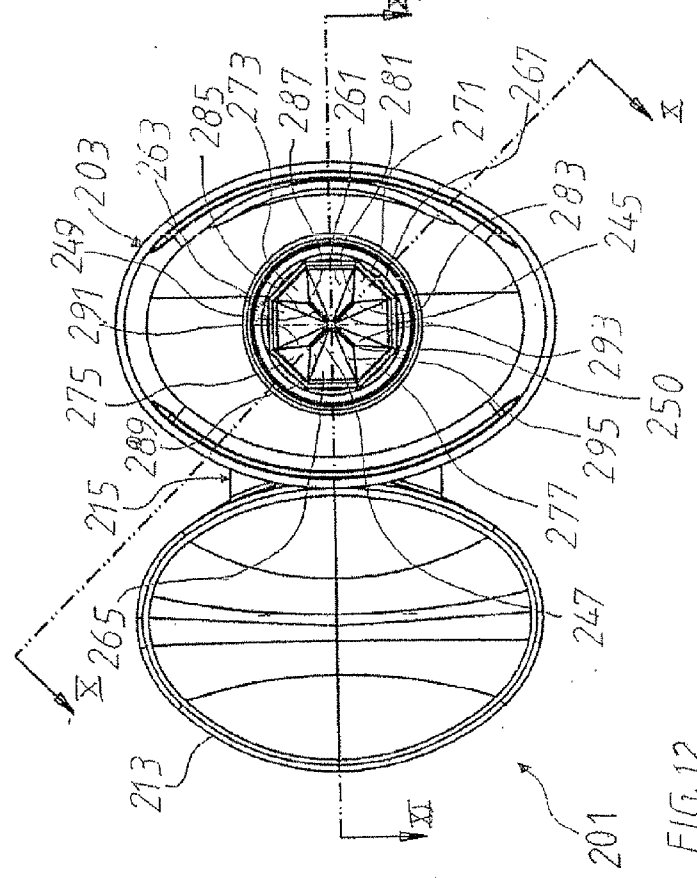

FIG. 12

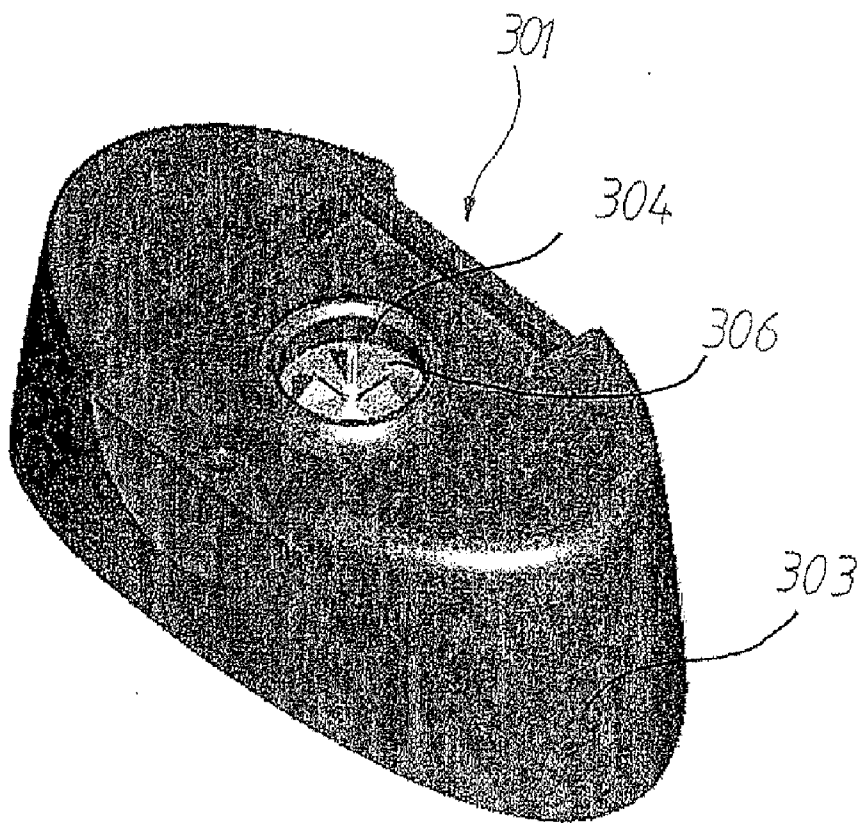

Fig. 13

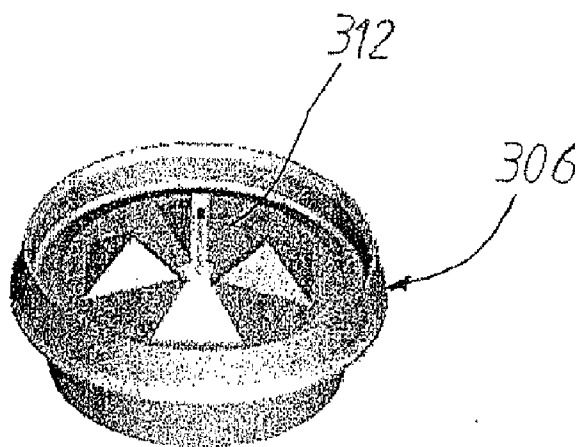

Fig. 14

CLOSURE FOR A CONTAINER CONTAINING A FLUID

[0001] The present invention concerns a closure, seal or cap for a container containing a fluid. The closure comprises a body to be placed on the container with an outlet opening via which the fluid is discharged when a container-internal excess pressure is generated. It is known, for generating the container-internal excess pressure, to construct the deformable container such that in the case of manual pressure on the walls of the container, the internal volume of the container is reduced and the desired internal pressure of the container can be generated. The fluid can then exit via a slotted structure constructed in the body, which comprises at least one slot. The at least one slot is defined by a pair of free terminal edges facing each other and ending in a common apex.

[0002] A closure of this type with a plurality of slots is known from the document WO82/01360, in which terminal edges of triangular pivoting plates are essentially adjacent in an activation state free of container-internal excess pressure and define an opening plane. When the container-internal excess pressure is generated, the terminal edges are opened by pivoting, moving away from the interior of the container, by the fluid, moving away from each other.

[0003] It has, however, been established that the known closure did not ensure a sufficient tightness at the level of the terminal edges, in particular in an activation state free of container-internal excess pressure. Furthermore, the discharge resistance with the known closure is so low that in the case of unintentional pressure on the walls of the container, fluid immediately leaves from the slots.

[0004] The aim of the invention is to overcome the disadvantages of the prior art, in particular to create a closure having a slotted structure with at least one slot which is defined by free terminal edges facing each other, with which a sufficient making tight is likewise guaranteed in an activation state free of container-internal excess pressure and a resistance to discharge flow is increased.

[0005] This aim is fulfilled by the characteristics of Claim 1.

[0006] According to the latter, a closure which comprises a body with an outlet opening via which the fluid can be discharged on the generation of a container-internal excess pressure and which is defined by a slotted structure having at least one slot, which is bounded by free terminal edges facing each other and ending in an apex. According to the invention, the slotted structure comprises multiple pivoting plates which are articulated to the body so as to be moveable, at least one pivoting plate, preferably each of the pivoting plates, being connected to an adjacent pivoting plate so as to be moveable, via a deformation section that is more flexible relative to the multiple pivoting plates, which forms one of the free terminal edges of the at least one slot, and in an activation state free of a container-internal excess pressure is arranged essentially adjacent to the other opposite free terminal edge of the at least one slot and can open by pivoting, moving away from the container interior when the container-internal excess pressure is generated by means of the fluid, thus moving away from the other free terminal edge.

[0007] In a preferred embodiment of the invention, the multiple pivoting plates are connected via a hinge-joint, in particular a film hinge-joint, to the body in such a way that, when the container-internal excess pressure is applied by

means of the fluid, they pivot, moving away, and deform the deformation section in such a manner that the terminal edge thereof moves away from the other terminal edge, moving apart from each other.

[0008] In an improvement of the invention, the two free terminal edges of the at least one slot are formed by two deformation sections which connect one pivoting plate to the two adjacent pivoting plates. In an activation state free of container-internal excess pressure, the two free terminal edges are parallel side by side. The terminal edges of the at least one slot are preferably essentially in the form of a straight line.

[0009] If several slots are provided for the slotted structure, these preferably terminate in a common point, in particular in an axial outlet opening center.

[0010] In an improvement of the invention, the multiple pivoting plates form primary and secondary pivoting plates, the primary pivoting plates lying in a common plane, and the secondary pivoting plates intersecting this plane at an angle, preferably of 20° to 70° or 30° to 60° in an activation state free of container-internal excess pressure.

[0011] In a preferred embodiment of the invention, in an activation state free of container-internal excess pressure, the primary pivoting plates of the multiple pivoting plates lie in a common plane which intersects the deformation sections at an angle, preferably of approximately 20° to 70° or 30° to 60°.

[0012] In an improvement of the invention, in an activation state free of container-internal excess pressure, primary pivoting plates of the multiple pivoting plates lie in a common plane which intersects the free terminal edges at an angle, preferably of approximately 20° to 70° or 30° to 60°, in particular in a center of the outlet opening. Alternatively, the primary pivoting plates can be inclined relative to each other.

[0013] Preferably a pivoting plate, in particular a secondary pivoting plate, and with the latter deformation sections adjacent thereto, form a pyramid, one long edge of which is slotted by the free terminal edges of the deformation section.

[0014] The slotted long edge can be directed towards a center of the outlet opening. Preferably, at least two of the three long sides of the pyramid shape have equal area. The slotted structure can be formed by at least two, preferably two, three or four pyramid shapes which are in particular respectively formed by one secondary pivoting plate and by the adjacent deformation sections, one primary pivoting plate lying between two pyramid shapes. Preferably, a base side of the pyramid shape lies in a plane which is defined by primary pivoting plates of the multiple pivoting plates in the activation state free of container-internal excess pressure. Alternatively, the secondary pivoting plates can be thick like the principal pivoting plates, but thin at the level of the hinges.

[0015] In a preferred embodiment of the invention, the pivoting plates, in particular the primary and secondary pivoting plates, are dimensioned with thicker walls than the deformation section, which is constructed for example as a connection attachment in the form of a film or membrane which is able to be flattened or to be bent. In a preferred embodiment of the invention, the pivoting plates, in particular the primary and secondary plates, and also the deformation sections, are produced from one piece, in particular by injection moulding.

[0016] The pivoting plates, in particular the primary and secondary plates, are preferably connected to the body via a

hinge-joint, in particular a film hinge-joint, with the hinge-joints extending in particular in an annular form around a center of the opening.

[0017] In an embodiment of the invention, the closure consists of two separate pieces, namely a base body to be connected to the container and an insert forming the slotted structure. Preferably, the insert is mounted on a passage formed in the base body. In particular, the two pieces are produced by an injection moulding of two components of plastic material.

[0018] The invention likewise concerns a container with a closure according to the invention. The closure can be fixed on the container, in particular screwed. The closure and the container are preferably produced from one piece, in particular by injection moulding.

[0019] Other advantages, properties and characteristics of the invention will be clearly evident from the following description of preferred embodiments with the aid of the attached drawings, in which:

[0020] FIG. 1 shows a perspective view of a closure according to the invention in a first embodiment;

[0021] FIG. 2 shows a top view of the closure of FIG. 1;

[0022] FIG. 3 shows a view in cross-section of the closure of FIG. 1 along the section line III-III of FIG. 4;

[0023] FIG. 4 shows a view in cross-section of the closure of FIG. 1 along the section line IV-IV of FIG. 3;

[0024] FIG. 5 shows a perspective view of a closure according to the invention in a second embodiment;

[0025] FIG. 6 shows a top view of the closure of FIG. 5;

[0026] FIG. 7 shows a view in cross-section of the closure of FIG. 5 along the section line VII-VII of FIG. 8;

[0027] FIG. 8 shows a side view of the closure of FIG. 5;

[0028] FIG. 9 shows a perspective view of a closure according to the invention in a third embodiment;

[0029] FIG. 10 shows a view in cross-section of the closure of FIG. 10 along the section line X-X of FIG. 12;

[0030] FIG. 11 shows a view in cross-section of the closure of FIG. 9 along the section line XI-XI of FIG. 12; and

[0031] FIG. 12 shows a top view of the closure of FIG. 9.

[0032] FIG. 13 shows a perspective view of a closure according to the invention in a fourth embodiment; and

[0033] FIG. 14 shows a perspective view of an insert forming the slotted structure.

[0034] In FIGS. 1 to 4, the seal according to the invention is given generally the reference number 1. The closure 1 comprises, as main element, a support body 3 which can be fixed on a container which is not shown. The support body 3 is in the form of an upturned cup with an oval lateral wall 5 over its entire periphery, which changes to horizontal base edge 7. A passage 11, bounded by an axial projecting centering ring 9, is formed in the edge base 7.

[0035] On one of the sides of the oval support body 3 with a greater curvature, a cover 13 is articulated via a film hinge 15. The cover 13 comprises on the internal face a cylindrical projection in the form of a socket 17 which is in internal contact with the centering ring 9 and ensures tightness in the closed state of the cover 13.

[0036] A slotted structure 12 in the passage 11 of the support body 3 is constructed in the embodiment of the closure 1 according to the invention shown in FIGS. 1 to 4 by means of two pyramids 20, 22 which exceed a horizontal plane E. The vertical of the plane E extends on the axis A of the seal 1. Connecting ribs 21, 23, 25, 27, joined in a fixed manner to the

support body 3, which hold the slotted structure 12 on the support body, lie in the plane E.

[0037] The two pyramids 20, 22 are arranged symmetrically relative to the axis, relative to each other, and comprise respectively a secondary triangular pivoting plate 29, 31 connected via a film hinge joint 33, 35 to the adjacent support rib 21, 25. The film hinge 33, 35 is arranged on the base face of the triangular shape of the same side of the secondary pivoting plates 31, 29. On the other faces of the branches of the secondary triangular pivoting plates 29, 31, two supple deformation sections having thin walls, which are produced in the form of supple film wings respectively 37, 39 and 41, 43 and more flexible than the secondary plate 29, 31, abut in one piece. The film wings 37, 39, 41, 43 respectively have a free terminal edge in the form of a straight line. The free terminal edges of the adjacent deformation sections 41, 43 essentially face each other in a parallel manner—in an activation state free of container-internal excess pressure—and form slots (45, 47) which are sketched with lines in bold print in FIGS. 1 and 2.

[0038] The terminal edges end in the point of the respective triangular secondary pivoting plate 29, 31, where they define an apex.

[0039] The film wings respectively 37, 41 and 39, 43 end respectively with an adjacent primary pivoting plate 51, 53, constructed thicker than the film wings 37 to 43 and, essentially, as thick as the secondary pivoting plate 29, 31. The primary pivoting plate 51, 53 has the form of an isosceles triangle, its base face being articulated by means of a film-hinge articulation to the adjacent support rib 23, 27 of the support body 3.

[0040] The behaviour of the slotted structure 12 when an excess fluid pressure is generated inside the container, which is not shown, for example due to the deformation of the deformable wall of the container and when the fluid contained in the container is pushed to emerge from the closure 1 at the level of the slotted structure 12, is described below.

[0041] In FIGS. 1 to 4, the closure 1 is shown in an activation state free of container-internal excess pressure, because the free terminal edges of the slots 45, 47 of the deformation sections 37 to 43 are placed parallel side by side with respect to each other, preventing at the maximum an outlet through the two slots defined by the terminal edges.

[0042] In the case of excess pressure in the container, the fluid flows from the interior towards the primary pivoting plates 51, 53 and the secondary pivoting plates 29, 31 of the slotted structure 12 and causes them to pivot upwards, moving them away from the interior of the container. Due to the pivoting of the primary and secondary pivoting plates 51, 53, 29, 31, the terminal edges of the respective deformation sections 37 to 43 are moved apart from each other, essentially by diverging around the apex at the point of the secondary pivoting plate 29, 31, by which an outlet opening gradually grows larger from a center Z in the form of a point around the axis A, so as to form a square according to the embodiment in accordance with FIGS. 1 to 4.

[0043] On the discharge of the container and the suppression of the container-internal excess pressure which follows, the primary and secondary pivoting plates 29, 31, 51, 53 return into the positions shown in FIGS. 1 to 4. In an activation state free of container-internal excess pressure, the primary pivoting plates 51, 53 lie in the horizontal plane E which is intersected by the secondary pivoting plates 29, 33 with an angle of approximately 30° to 80°, preferably 50°. The ter-

minal edges of the slots **45, 47**, which extend from the point of the triangular pivoting plate **29, 31** to the axial center of the outlet opening, likewise intersect the horizontal plane with an angle of approximately 50°.

[0044] FIGS. **5** to **7** show another preferred embodiment of the closure according to the invention, the same reference numbers being used as for the embodiment according to FIGS. **1** to **4**, but increased by 100, for identical and similar components of the closure so as to simplify the reading of the description of the figures.

[0045] The embodiment according to FIGS. **5** to **8** is distinguished in particular from that according to FIGS. **1** to **4** by the fact that three pyramids **102, 122, 124** are now formed, instead of only two. The pyramids **120, 122, 124** are arranged in a star formation around the axial center *Z* of the outlet opening. The pyramids **120, 122, 124** are separated by three primary pivoting plates **161, 163, 165** and comprise respectively a secondary pivoting plate **171, 173, 175**. On the two sides of each secondary pivoting plate **171, 173, 175**, a thin-walled film wing **181, 183; 185, 187; 189, 191**, produced by injection moulding on the respective adjacent primary pivoting plate **161, 163** and **165**, is respectively provided. The respective film wings **181** to **191** define three slots **145, 147, 149** which are made clearly visible by the line in bold type. The slots **145, 147, 149** extend in a star formation towards the center of the outlet opening *Z* and are parallel to each other in an activation state free of container-internal excess pressure.

[0046] FIGS. **5** to **8** show the activation state free of container-internal excess pressure. When a container-internal pressure is generated and fluid leaves, the pivoting plates, namely the primary and secondary pivoting plates **161, 163, 165, 171, 173, 175** pivot upwards, moving away from the interior of the container, by which the terminal edges of the slots **145, 147, 149** are separated from each other, moving apart, and a polygonal symmetrical, namely hexagonal, contour is formed.

[0047] It is clear that it is possible to provide more than three pyramids for the slotted structure **12, 112**. As a function of the viscosity of the fluid, the number of slots can be adapted to the desired flow for the fluid with the seal. The whole of the closure **1, 101** is preferably produced by injection moulding in a single piece, in particular from polyethylene, polypropylene and/or polyolefin.

[0048] FIGS. **8** to **12** show another preferred embodiment of the seal according to the invention, the same reference numbers as for the embodiment according to FIGS. **1** to **4** and **5** to **8** respectively, but increased by 100 or 200 respectively, being used for identical and similar components of the seal so as to simplify the reading of the description of the figures. The embodiment according to FIGS. **9** to **12** is distinguished in particular from those according to FIGS. **1** to **4** and FIGS. **5** to **8** by the fact that four pyramids **220, 222, 224, 226** are formed instead of two or three pyramids. The pyramids **220, 222, 224, 226** are arranged in a star formation about the axial center *Z* of the outlet opening. The pyramids are separated by four primary pivoting plates **261, 263, 265, 267** and comprise respectively a secondary pivoting plate **271, 273, 275, 277**. On two sides of each secondary, pivoting plate, a thin-walled film wing **281, 283, 285, 287, 289, 291, 293, 295**, produced by injection moulding on the respective adjacent primary pivoting plate is respectively provided. The respective film wings **282** to **295** define four slots **245, 247, 249, 250**, two of which slots lie on a straight line and form a cross viewed above.

[0049] The embodiment of the closure **301** according to FIGS. **12** and **13** is distinguished in particular from that in accordance with the embodiments below in that the closure **301** is made by an injection moulding of two components of plastic material. The first piece forms a support body **303** having a passage **304**. In the passage **304**, a circular insert **306** is positioned and fixed to the support body **303**. In the middle of the insert **306**, the slotted structure **312** is formed. The material for the insert **306** is more flexible than the material for the support body **303**.

[0050] The characteristics exposed in the above description, in the figures and in the claims can be important, both separately and in combination as desired for the embodiment of the invention in the different configurations.

LIST OF REFERENCES

1, 101, 201, 301	closure
3, 103, 203, 303	support body
304	passage
5, 105, 205	lateral wall
306	insert
7, 107, 207	edge base
9, 109, 209	centering ring
11, 111, 211	passage
12, 112, 212, 312	slotted structure
13, 113, 213	cover
15, 33, 35, 55, 57, 115, 215	film hinge joint
17, 117, 217	projection
20, 22, 120, 122, 124	pyramid
220, 222, 224, 226	pyramid
21, 23, 25, 27	connecting ribs
29, 31, 171, 173, 175	secondary pivoting plate
271, 273, 275, 277	secondary pivoting plate
37, 39, 41, 43, 181, 183, 185	film wing
187, 189, 191, 281, 283, 285	film wing
287, 289, 291, 293, 295	film wing
45, 47, 145, 147, 149	slots
245, 247, 249, 250	slots
51, 53, 161, 163, 165	primary pivoting plate
261, 263, 265, 267	primary pivoting plate
A	axis
E	plane
Z	center

1. A closure for a container containing a fluid, comprising a body with an outlet opening, via which the fluid is discharged when it generates a container-internal excess pressure, and which is bounded by a slotted structure with at least one slot, which is defined by free terminal edges facing each other and ending in a common apex, characterized in that the slotted structure comprises multiple pivoting plates, which are hinge-connected to the body so that they can pivot, wherein at least one pivoting plate is connected to an adjacent pivoting plate so as to be moveable, via a deformation section that is more flexible relative to the multiple pivoting plates and forms one of the free terminal edges of the at least one slot, and in an activation state free of a container-internal excess pressure is arranged essentially adjacent to the other opposite free terminal edge of the at least one slot, and when the container-internal excess pressure is generated by means of the fluid can be pivoted upwards away from the container interior and is thus removed from the other free terminal edge.

2. The closure according to claim 1, characterized in that the multiple pivoting plates are connected via a hinge-joint to the body in such a way that, when applying the container-internal excess pressure by means of the fluid, they are pivoted away from the container interior and deform the defor-

mation section in such a manner that the terminal edge thereof is forced apart from the other terminal edge.

3. The closure according to claim 1, characterized in that both free terminal edges of the at least one slot are formed by two deformation sections, which connect one pivoting plate to both of the adjacent pivoting plates.

4. The closure according to claim 1, characterized in that the terminal edges of the at least one slot are essentially in the form of a straight line.

5. The closure according to claim 1, characterized in that the multiple pivoting plates comprise primary and secondary pivoting plates, wherein in the activation state free of container-internal excess pressure the primary pivoting plates lie in a common plane E and the secondary pivoting plates intersect this plane at an angle of about 30° to 60°.

6. The closure according to claim 1, characterized in that primary pivoting plates of the multiple pivoting plates, in the activation state free of container-internal excess pressure, lie in a common plane E, which the deformation sections intersect at an angle of about 20° to 70° or about 30° to 60°.

7. The closure according to claim 5, characterized in that primary pivoting plates of the multiple pivoting plates, in the activation state free of container-internal excess pressure, lie in a common plane E, which the terminal edges of the deformation sections intersect at an angle of about 20° to 70° or about 30° to 60°.

8. The closure according to claim 1, characterized in that a pivoting plate and deformation sections adjacent thereto form a pyramid shape with three axial long sides, of which one long edge is slotted through the free terminal edges of the deformation section.

9. The closure according to claim 8, characterized in that the slotted long edge points towards a center Z of the outlet opening.

10. The closure according to claim 8, characterized in that at least two of three long sides of the pyramid shape have equal area.

11. The closure according to claim 8, characterized in that the slotted structure is formed by at least two separate pyramid shapes with three axial long sides, which are each formed by one secondary pivoting plate and the deformation sections adjacent thereto, wherein one primary pivoting plate lies between two pyramid shapes.

12. The closure according to claim 8, characterized in that a radial base side of the pyramid shape lies in a plane E, which is defined by primary pivoting plates of the multiple pivoting plates in the activation state free of container-internal excess pressure.

13. The closure according to claim 1, characterized in that the pivoting plates have thicker walls than the deformation section.

14. The closure according to claim 1, characterized in that said closure and the deformation sections, are constructed from one piece.

15. The closure according to claim 1, characterized in that the pivoting plates are each connected to the body via a hinge-joint, wherein the hinge-joint is extended in an annular form around a center Z of the outlet opening.

16. The closure according to claim 1, characterized in that the closure is formed from two separate pieces one of which forms a support body for being connected to the container and the other of which forms an insert defining the slotted structure.

17. The closure according to claim 1 further in combination with a container.

18. The closure according to claim 17, wherein the closure is fixed to the container by means of screws or clamps.

19. The closure according to claim 17, wherein the container and the closure are made from one piece.

* * * * *