



(51) International Patent Classification:

A61K 8/31 (2006.01) A61K 8/92 (2006.01)
A61Q 1/10 (2006.01) A61K 8/04 (2006.01)

(21) International Application Number:

PCT/EP2016/050218

(22) International Filing Date:

7 January 2016 (07.01.2016)

(25) Filing Language:

English

(26) Publication Language:

English

(30) Priority Data:

1550101 7 January 2015 (07.01.2015) FR

(71) Applicant: L'OREAL [FR/FR]; 14 Rue Royale, 75008 Paris (FR).

(72) Inventors: BARBA, Claudia; 58 rue Faubourg Poissonnière, 75010 Paris (FR). LEMERRER, Carole; 188 rue Paul Hochart BP553, 94152 Chevilly Larue (FR).

(74) Agent: CABINET NONY; 3 rue de Penthièvre, 75008 Paris (FR).

(81) Designated States (unless otherwise indicated, for every

kind of national protection available): AE, AG, AL, AM, AO, AT, AU, AZ, BA, BB, BG, BH, BN, BR, BW, BY, BZ, CA, CH, CL, CN, CO, CR, CU, CZ, DE, DK, DM, DO, DZ, EC, EE, EG, ES, FI, GB, GD, GE, GH, GM, GT, HN, HR, HU, ID, IL, IN, IR, IS, JP, KE, KG, KN, KP, KR, KZ, LA, LC, LK, LR, LS, LU, LY, MA, MD, ME, MG, MK, MN, MW, MX, MY, MZ, NA, NG, NI, NO, NZ, OM, PA, PE, PG, PH, PL, PT, QA, RO, RS, RU, RW, SA, SC, SD, SE, SG, SK, SL, SM, ST, SV, SY, TH, TJ, TM, TN, TR, TT, TZ, UA, UG, US, UZ, VC, VN, ZA, ZM, ZW.

(84) Designated States (unless otherwise indicated, for every

kind of regional protection available): ARIPO (BW, GH, GM, KE, LR, LS, MW, MZ, NA, RW, SD, SL, ST, SZ, TZ, UG, ZM, ZW), Eurasian (AM, AZ, BY, KG, KZ, RU, TJ, TM), European (AL, AT, BE, BG, CH, CY, CZ, DE, DK, EE, ES, FI, FR, GB, GR, HR, HU, IE, IS, IT, LT, LU, LV, MC, MK, MT, NL, NO, PL, PT, RO, RS, SE, SI, SK, SM, TR), OAPI (BF, BJ, CF, CG, CI, CM, GA, GN, GQ, GW, KM, ML, MR, NE, SN, TD, TG).

Published:

— with international search report (Art. 21(3))

(54) Title: SUNFLOWER WAX AND VOLATILE HYDROCARBON-BASED OIL MASCARA

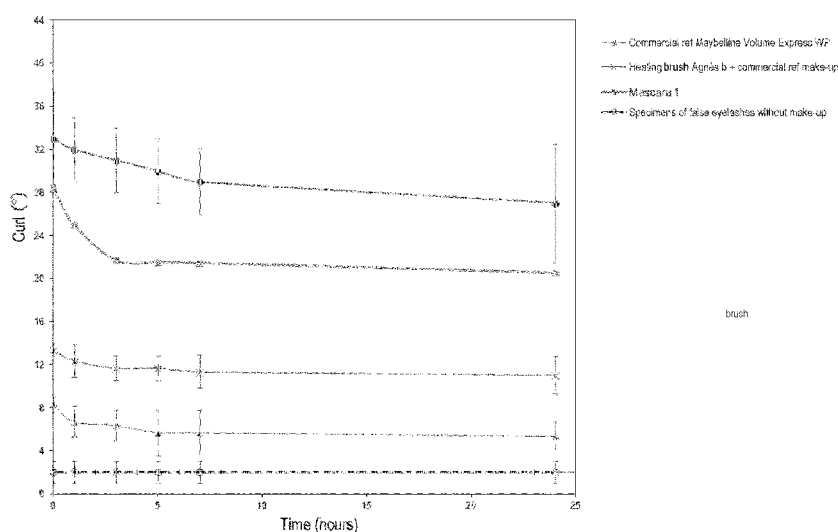

Figure 3

(57) Abstract: The present invention relates to an assembly for packaging and applying a composition for making up and/or caring for keratin fibres, especially the eyelashes or the eyebrows, comprising: i) an anhydrous makeup and/or care composition comprising at least one sunflower wax and a volatile hydrocarbon-based oil, ii) a member for applying said composition, and iii) heating means for bringing said composition to a temperature suitable for its deformability. An anhydrous composition, especially a cosmetic composition, comprising at least one sunflower wax and a volatile hydrocarbon-based oil and also the use thereof are also claimed.



"Sunflower wax and volatile hydrocarbon-based oil mascara"

The present invention relates to the field of making up and/or caring for keratin materials. The invention relates firstly to an assembly for packaging and applying a composition for making up and/or caring for keratin fibres.

5 The invention also relates to a cosmetic composition for coating keratin fibres, such as the eyelashes and the eyebrows, or alternatively false eyelashes, the application of which is compatible with heating.

The invention also relates to a corresponding cosmetic process for making up and/or caring for these keratin materials.

10 More particularly, the compositions under consideration according to the invention are in the form of an eyelash product such as a mascara, or an eyebrow product. It is advantageously a mascara.

The term "mascara" means a composition intended to be applied to the eyelashes: it may be an eyelash makeup composition, an eyelash makeup base (also known
15 as a base coat), a composition to be applied over a mascara, also known as a top coat, or a cosmetic composition for treating the eyelashes. Mascara is more particularly intended for human eyelashes, but also for false eyelashes.

According to one of its aspects, the present invention relates more particularly to "curling" mascaras.

20 Such compositions, especially based on hard waxes and tensioning polymers, and which are intended for cold application, are described in particular in patent EP 0 928 607. With these compositions, the eyelash-curling effect may occasionally be judged insufficient. In addition, its persistence over time is not optimal.

In patent application WO 00/74519, mention is made of improved curling
25 properties by using organogelling agents to replace all or some of the waxes of the composition. Experience has shown that the results obtained in terms of curling are disappointing.

Moreover, various types of devices termed "eyelash-curling" exist.

30 According to a first type, the device is configured in the form of pincers which, when cold, before application of the makeup, pinch the eyelashes so as to induce a curvature on them before making them up. The implementation of this method is far from simple to achieve. Furthermore, this method has the major drawback of degrading the

morphology of the eyelashes, or even of pulling out the eyelashes. In addition, the results are not optimal in terms of curl amplitude and above all of curl durability.

It is also known practice to use such a device after applying product. Experience has shown that the quality of the deposit is deteriorated by this subsequent
5 eyelash shaping step.

What is more, this type of makeup application is performed in two actions, the first directed towards applying the makeup composition onto the keratin fibres, and the second directed towards mechanically producing curling of the keratin fibre coated with the composition. For obvious reasons, this requires more time on the user's part, very often
10 with the impossibility of reproducing the same quality of makeup result at each use.

More recently, patent US-A-5 775 344 has described an assembly for packaging and applying a product, especially for the eyelashes, comprising a container containing the composition to be applied. A lid intended to block off an aperture of the container is securely fastened to a heating stem, one end of which is securely fastened to an
15 applicator, especially in the form of a brush. The walls of the container are equipped with heating means so as to heat the contents thereof before opening the container.

This type of device is thus suitable for applying makeup in a single action, the composition being heated before application.

However, the heated product may undergo harmful changes in the course of the
20 heatings to which it is subjected, for example having an impact on the stability of the product in the container, which may then be manifested by the formation of a non-uniform deposit during its application to the keratin fibre or more generally by a significant loss of quality of the product contained in the container, which may go so far as to make it impossible to take up and/or apply the product.

Moreover, the compositions currently proposed with this type of device do not
25 prove to be satisfactory for affording a substantial initial curling effect whose persistence is long-lasting.

The object of the present invention is, precisely, to satisfy this need.

30 The main aim of the present invention is thus to propose a composition for coating keratin fibres, which allows improved curling of the eyelashes especially under the action of heat, and which in particular has good application properties in terms of glide

and play time, this improvement being both in terms of the initial curling and of the persistence of this curling over time.

5 The present invention is also directed towards proposing a composition for coating keratin fibres which has good application properties in terms of glidance and play time.

For the purposes of the invention, the term "play time" is especially representative of the frequency of sweeping of the applicator through the eyelashes up to the appearance of the first grains, without the application being impeded by a dragging sensation.

10 Another aim is also to propose a composition that is compatible with application using a heating instrument, such as a heating brush, which can take up the composition, heat it and apply the composition thus heated.

Another aim of the present invention is to propose a composition for coating keratin fibres, preferably a mascara, which has good persistence on the eyelashes, and
15 which is compatible with heating during its application.

Another aim of the present invention is to obtain a composition for coating keratin fibres, preferably a mascara, which produces a charging deposit.

Another aim of the present invention is also to propose a composition for coating keratin fibres, preferably a mascara, which allows good separation of the eyelashes
20 during its application.

Thus, according to a first of its aspects, the present invention relates to an assembly for packaging and applying a composition for making up and/or caring for keratin fibres, especially the eyelashes or the eyebrows, comprising:

25 i) an anhydrous makeup and/or care composition comprising at least one sunflower wax and a volatile hydrocarbon-based oil,
ii) a member for applying said composition, and
iii) heating means for bringing said composition to a temperature suitable for its deformability.

30 Advantageously, the composition may be contained in an assembly of the invention inside a container or reservoir.

Advantageously, the means for heating a packaging and application assembly according to the invention are capable of bringing the composition to a temperature of greater than or equal to 30°C, preferably greater than or equal to 45°C, in particular to a temperature of between 50°C and 75°C and better still between 60°C and 65°C.

5 Advantageously, these heating means are combined with the application element.

As stated previously, the combination of a composition according to the invention with a heating tool proves to produce a beneficial effect on the desired effect.

10 Thus, a composition according to the invention, which is non-invasive for the eyelashes, advantageously has an immediate curling effect of greater than or equal to 15° relative to an initial non-made-up state of a specimen of false eyelashes.

In addition, and as emerges from the examples that follow, the inventors have found, surprisingly, that the compositions according to the invention have a persistence of the curl of made-up eyelashes relative to an initial state of the non-made-up eyelashes of at least 6 hours, in particular at least 12 hours and better still up to 24 hours. This curl persistence may be evaluated according to the makeup and evaluation protocol given hereinbelow. More specifically, between the initial curled made-up state and the final curled made-up state, after 6 hours, better still 12 hours, or even 24 hours, a maximum loss of curl of less than or equal to 30% is advantageously observed.

20

According to an advantageous embodiment, said composition also comprises as volatile hydrocarbon-based oil at least isododecane and preferably isododecane and isoheptadecane.

25 According to another embodiment, the compositions under consideration according to the invention comprise at least one volatile silicone oil. In particular, the volatile silicone oil may be chosen from linear or cyclic silicone oils, in particular linear or cyclic polydimethylsiloxanes (PDMSs) containing from 3 to 7 silicon atoms.

According to a particular embodiment, a composition according to the invention is a mascara.

30

According to one embodiment, the compositions under consideration according to the invention comprise at least one polymer chosen from the group consisting of semicrystalline polymers, in particular chosen from poly(C₁₀-C₃₀)alkyl acrylates;

liposoluble film-forming polymers, especially a vinyl ester copolymer; and polymers (A) derived from the (co)polymerization of at least one at least C₄ alkene monomer, and preferably comprises at least one semicrystalline polymer, at least one liposoluble film-forming polymer and at least one polymer (A) derived from the (co)polymerization of at least one at least C₄ alkene monomer.

In particular, polymer (A) may have a weight-average molecular mass of greater than or equal to 750 g/mol, advantageously between 800 and 10 000 g/mol, more preferentially between 900 and 5000 g/mol and is preferably a poly-1-butene homopolymer.

According to one embodiment, the compositions under consideration according to the invention also comprise at least one microwax, in particular a carnauba microwax.

According to one embodiment, the compositions under consideration according to the invention also comprise at least one non-volatile oil.

According to another embodiment, the compositions under consideration according to the invention comprise at least one dyestuff, preferably chosen from pulverulent materials, liposoluble dyes and water-soluble dyes, and mixtures thereof.

According to another of its aspects, the present invention is also directed towards an anhydrous composition, especially a cosmetic composition, comprising at least one sunflower oil and a volatile hydrocarbon-based oil.

A subject of the invention is also a non-therapeutic cosmetic process for making up and/or caring for keratin fibres, especially the eyelashes or the eyebrows, comprising the application to said keratin fibres of a cosmetic composition according to the present invention, said composition being heated to a temperature of greater than or equal to 30°C, preferably greater than or equal to 45°C, in particular to a temperature of between 50°C and 75°C and better still between 60°C and 65°C.

In the preferred embodiment variant of the invention, the compositions are heated before application to the keratin fibres.

According to a preferred variant, the composition under consideration according to the invention is a composition for coating the eyelashes, in particular for

caring for and/or making up the eyelashes and/or the eyebrows, and more particularly a mascara.

The present invention relates more particularly to anhydrous mascaras or mascaras with a low water content, known as waterproof mascaras, in the form of
5 dispersions of waxes in organic solvents, in particular volatile organic solvents, more particularly volatile C₈-C₁₆ hydrocarbon-based solvents.

The term "anhydrous composition" means a composition containing less than 5% by weight of water, better still less than 2% by weight of water, or even less than 0.5% by weight of water, and which is especially free of water, relative to the total weight of the
10 composition. Where appropriate, such small amounts of water may especially be introduced by ingredients of the composition that may contain residual amounts thereof.

According to a particular aspect, a subject of the present invention is the cosmetic use of a composition according to the present invention, for obtaining a film
15 deposited on keratin fibres, especially the eyelashes or the eyebrows, which is uniform and which has improved curling properties and/or improved persistence of this curling over time.

Finally, according to another of its aspects, a subject of the present invention is the cosmetic use of a composition according to the present invention, for obtaining a
20 mascara which has good play time properties.

DETAILED DESCRIPTION OF THE COMPOSITION ACCORDING TO THE INVENTION

As emerges from the foregoing, the compositions according to the invention
25 are suitable for deposition onto keratin fibres such as the eyelashes or the eyebrows.

I. Characteristics of the physical properties

Curling effect and durability of this effect

An improved immediate curling effect, which was prolonged over time, of the
30 keratin materials onto which a composition according to the invention is applied was also

noted. This curling was evaluated in accordance with the method explained later in the present text.

Thus, in accordance with this method, a curling effect of a composition tested on a specimen of false eyelashes is evaluated by comparison with the curling of the eyelashes before application of the composition.

To do this, photos of the eyelashes are taken before and after application of the test composition, if necessary at different times after application to observe the duration over time of this effect.

The measurements are taken manually on the photos with a protractor, and make it possible to determine a median angle (a) created between the base of the specimen and the line of the medium height of the false eyelash fringe.

As illustrated in Figure 2, the greater the angle "a", the more curled the eyelashes.

A composition according to the invention, which is non-invasive for the eyelashes, thus preferably has an initial curling effect of greater than or equal to 15°, or even greater than or equal to 20°, relative to an initial non-made-up state of a false eyelash specimen, and conserves after 8 hours, better still after 12 hours and even better still after 24 hours, an eyelash curling effect of greater than or equal to 15°, or even greater than or equal to 20°.

Between the initial curled made-up state and the final curled made-up state, after 6 hours, better still 12 hours, or even 24 hours, a maximum loss of curl of less than or equal to 30% is advantageously observed.

Play time

The compositions according to the invention advantageously have an optimized play time.

For the purposes of the invention, the play time qualifies the number of sweeps of the applicator through the eyelashes up to the appearance of the first grains, without the application being impeded by a dragging sensation.

A protocol for qualifying this play time is detailed in the examples below. With regard to the number of sweeps of the brush up to the appearance of the grains, the compositions are graded on a scale ranging from 1 (very good play time) to 5 (very poor

play time), the formulations of the invention thus advantageously have a play time of less than 4 and more precisely of 3, representative of a satisfactory play time.

After 15 sweeps of the brush, the false eyelash specimen does not show any grains after being made up with a composition in accordance with the invention. The
5 formulations of the invention thus advantageously have a play time value, measured in accordance with the protocol indicated below, of less than 4.

Viscosity

The compositions according to the invention advantageously have a texture
10 suitable for handling them with a brush of mascara type. They are thus advantageously deformable in response to a mechanical stimulus, but also a thermal stimulus.

According to a preferred variant, a cosmetic composition according to the invention is fluid at room temperature.

For the purposes of the invention, the term "fluid" is intended to characterize
15 the fact that a composition according to the invention is not solid. In other words, it manifests a fluidity sufficient to have flow properties. A composition of mascara type is, for example, representative of this type of fluidity.

In particular, a composition according to the invention may advantageously
20 have a viscosity, evaluated with a Rheomat RM200® machine with a No. 5 spindle at 25°C and 1 atm, ranging from 0.1 Pa.s to 50 Pa.s and better still ranging from 5 Pa.s to 30 Pa.s.

II. Characterization of the compounds of the composition

25 As emerges from the foregoing, a composition according to the invention comprises at least one sunflower wax and at least one volatile hydrocarbon-based solvent.

Sunflower wax

In a general manner, the term "wax" means a lipophilic compound, which is
30 solid at room temperature (25°C), with a reversible solid/liquid change of state, which has a melting point of greater than or equal to 30°C, which may be up to 200°C.

Within the context of the invention, the melting point corresponds to the temperature of the most endothermic peak observed in thermal analysis (DSC) as described in the standard ISO 11357-3; 1999. The melting point of the wax may be measured using a differential scanning calorimeter (DSC), for example the calorimeter sold under the name
5 *MDSC 2920* by the company TA Instruments.

The measuring protocol is as follows:

A 5 mg sample of wax placed in a crucible is subjected to a first temperature rise ranging from -20°C to 100°C, at a heating rate of 10°C/minute, and then is cooled from 100°C to -20°C at a cooling rate of 10°C/minute and is finally subjected to a second
10 temperature rise ranging from -20°C to 100°C at a heating rate of 5°C/minute. During the second temperature rise, the variation in the difference in power absorbed by the empty crucible and by the crucible containing the sample of wax is measured as a function of the temperature. The melting point of the compound is the temperature value corresponding to the top of the peak of the curve representing the variation in the difference in power
15 absorbed as a function of the temperature.

As sunflower oils that are suitable for use in the invention, mention may be made especially of those sold especially by Koster Keunen under the name Sunflower wax. Such a wax preferably comprises at least 90% of C42 to C60 compound(s), better still at
20 least 95%, or even at least 99% of such compound(s).

A composition according to the invention may especially comprise from 0.1% to 10% by weight and in particular from 1% to 5% by weight of sunflower wax relative to the total weight of the composition.

Needless to say, this sunflower wax may be advantageously combined with one
25 or more additional waxes.

Advantageously, if at least one other wax is present, the sunflower wax represents not more than 25% by weight of the total weight of wax relative to the total weight of the composition.

30 **Additional wax**

The term "additional wax" means a wax that is not introduced in micron form into said composition according to the invention and which is different from sunflower wax.

Preferably, during the preparation of a composition according to the invention, this (these) additional wax(es) undergo a heating step which leads to at least partial melting of said additional wax(es).

The additional wax(es) may be present in a composition according to the invention such that the total amount of additional wax and sunflower wax represents a content of greater than or equal to 5% by weight, preferably between 5% and 30% by weight, especially between 8% and 20% by weight and preferably between 10% and 15% by weight, relative to the total weight of the composition.

These additional waxes are chosen from waxes that are solid at room temperature (25°C), of animal, plant, mineral or synthetic origin, and mixtures thereof. These additional waxes advantageously have crystalline properties.

A composition according to the invention preferably comprises at least one additional wax chosen from the group formed by polar waxes and apolar waxes, and a mixture thereof, and in particular comprises at least one polar wax and at least one apolar wax.

Preferably, a composition according to the invention comprises at least one additional wax chosen from the group formed by carnauba wax, beeswaxes, especially white beeswax, ozokerite wax and paraffin wax, and mixtures thereof.

a) Apolar waxes

For the purposes of the present invention, the term "apolar wax" means a wax whose solubility parameter at 25°C as defined below, δ_a , is equal to 0 (J/cm³)^{1/2}.

The definition and calculation of the solubility parameters in the Hansen three-dimensional solubility space are described in the article by C.M. Hansen: *The three-dimensional solubility parameters*, J. Paint Technol. 39, 105 (1967).

According to this Hansen space:

- δ_D characterizes the London dispersion forces derived from the formation of dipoles induced during molecular impacts;

- δ_p characterizes the Debye interaction forces between permanent dipoles and also the Keesom interaction forces between induced dipoles and permanent dipoles;

- δ_h characterizes the specific interaction forces (such as hydrogen bonding, acid/base, donor/acceptor, etc.); and

5 - δ_a is determined by the equation: $\delta_a = (\delta_p^2 + \delta_h^2)^{1/2}$.

The parameters δ_p , δ_h , δ_D and δ_a are expressed in $(\text{J}/\text{cm}^3)^{1/2}$.

The apolar waxes are in particular hydrocarbon-based waxes formed solely from carbon and hydrogen atoms, and free of heteroatoms such as N, O, Si and P.

10 The apolar waxes are chosen from microcrystalline waxes, paraffin waxes, ozokerite and polyethylene waxes, and mixtures thereof.

An ozokerite that may be mentioned is Ozokerite Wax SP 1020 P.

As microcrystalline waxes that may be used, mention may be made of Multiwax W 445[®] sold by the company Sonneborn, and Microwax HW[®] and Base Wax 30540[®] sold by the company Paramelt, and Cerewax[®] No. 3 sold by the company
15 Baerlocher.

Polyethylene waxes that may be mentioned include Performalene 500-L Polyethylene and Performalene 400 Polyethylene sold by New Phase Technologies, and Asensa[®] SC 211 sold by the company Honeywell, and a paraffin that may be mentioned is Ceraffine 56-58 sold by Baerlocher.

20

b) Polar waxes

For the purposes of the present invention, the term "*polar wax*" means a wax whose solubility parameter at 25°C, δ_a , is other than 0 $(\text{J}/\text{cm}^3)^{1/2}$.

25 In particular, the term "*polar wax*" means a wax whose chemical structure is formed essentially from, or even constituted by, carbon and hydrogen atoms, and comprising at least one highly electronegative heteroatom such as an oxygen, nitrogen, silicon or phosphorus atom.

The polar waxes may in particular be hydrocarbon-based, fluoro or silicone waxes.

30

Preferentially, the polar waxes may be hydrocarbon-based waxes.

The term "*hydrocarbon-based wax*" means a wax formed essentially from, or even constituted by, carbon and hydrogen atoms, and optionally oxygen and nitrogen

atoms, and that does not contain any silicon or fluorine atoms. It may contain alcohol, ester, ether, carboxylic acid, amine and/or amide groups.

According to the invention, the term "*ester wax*" means a wax comprising at least one ester function. According to the invention, the term "*alcohol wax*" means a wax
5 comprising at least one alcohol function, i.e. comprising at least one free hydroxyl (OH) group.

In particular, use may be made, as polar waxes, of those chosen from:

i) waxes of formula R_1COOR_2 in which R_1 and R_2 represent linear, branched or cyclic aliphatic chains in which the number of atoms ranges from 10 to 50, which may
10 contain a heteroatom such as O, N or P and whose melting point ranges from 25 to 120°C;

ii) bis(1,1,1-trimethylolpropane) tetrastearate, sold under the name Hest 2T-4S[®] by the company Heterene;

iii) diester waxes of a dicarboxylic acid of general formula $R^3-(-OCO-R^4-COO-R^5)$, in which R^3 and R^5 are identical or different, preferably identical, and represent
15 a C_4-C_{30} alkyl group (alkyl group comprising from 4 to 30 carbon atoms) and R^4 represents a linear or branched C_4-C_{30} aliphatic group (alkyl group comprising from 4 to 30 carbon atoms) which may or may not comprise one or more unsaturations and which is preferably linear and unsaturated;

iv) mention may also be made of the waxes obtained by catalytic
20 hydrogenation of animal or vegetable oils having linear or branched C_8-C_{32} fatty chains, for example such as hydrogenated jojoba oil, hydrogenated castor oil, hydrogenated coconut oil, and also the waxes obtained by hydrogenation of castor oil esterified with cetyl alcohol;

v) beeswax, synthetic beeswax, polyglycerolated beeswax, carnauba wax,
25 candelilla wax, oxypropylenated lanolin wax, rice bran wax, ouricury wax, esparto grass wax, cork fibre wax, sugar cane wax, Japan wax, sumac wax, montan wax, orange wax, laurel wax, hydrogenated jojoba wax, lemon wax, olive wax or berry wax.

According to another embodiment, the polar wax may be an alcohol wax. According to the invention, the term "*alcohol wax*" means a wax comprising at least one
30 alcohol function, i.e. comprising at least one free hydroxyl (OH) group. Examples of alcohol waxes that may be mentioned include the C_{30-50} alcohol wax Performacol[®] 550 Alcohol sold by the company New Phase Technologies, stearyl alcohol and cetyl alcohol.

It is also possible to use silicone waxes, which may advantageously be substituted polysiloxanes, preferably of low melting point.

The term "*silicone wax*" means an oil comprising at least one silicon atom, and in particular comprising Si-O groups.

5 Among the commercial silicone waxes of this type, mention may be made in particular of those sold under the names Abilwax 9800, 9801 or 9810 (Goldschmidt), KF910 and KF7002 (Shin-Etsu), or 176-1118-3 and 176-11481 (General Electric).

The silicone waxes that may be used may also be alkyl or alkoxy dimethicones, and also (C₂₀-C₆₀) alkyl dimethicones, in particular (C₃₀-C₄₅)alkyl dimethicones, such as
10 the silicone wax sold under the name SF-1642 by the company GE-Bayer Silicones or C₃₀-C₄₅ alkyl dimethylsilyl polypropylsilsesquioxane under the name SW-8005[®] C30 Resin Wax sold by the company Dow Corning.

In the context of the present invention, particularly advantageous waxes that may be mentioned include beeswax, for example the product sold under the name White
15 Beeswax SP-453P by the company Strahl & Pitsch, or a paraffin wax.

According to a particular variant, a composition of the invention may also comprise at least one wax in a micronized form, referred to as a "microwax" and advantageously of carnauba and/or mixtures thereof.

20 The term "micronized wax" or "microwax" means a wax which is in a pulverulent form and whose particle size is between 0.5 and 50 microns, preferably between 1 and 30 microns, or even between 3 and 25 microns.

This (these) microwax(es) are introduced in micron form into said composition according to the invention. In particular, during the preparation of a composition in
25 accordance with the invention, this (these) microwax(es) do not undergo a heating step, since they are preferably introduced cold, i.e. at a temperature such that the microwax(es) do not undergo melting.

The microwaxes that may be used in the compositions according to the invention are chosen from waxes that are solid and rigid at room temperature, of animal,
30 plant, mineral or synthetic origin, and mixtures thereof.

Preferably, the microwaxes according to the invention have a melting point ranging from 60°C to 160°C, in particular greater than or equal to 70°C, especially ranging from 80°C to 150°C, especially ranging from 80°C to 140°C, or even from 80°C to 105°C.

It should be noted that care will be taken in the manufacturing process not to melt the microwax. Advantageously, the temperature of the composition during the manufacturing process does not exceed a temperature less than 30°C relative to the melting point of the microwax.

Advantageously, the heating temperature of the heating means is less than or equal to 5°C relative to the melting point of the microwax(es), preferably strictly less than 5°C relative to the melting point of the microwax(es).

According to a preferred embodiment, the micronized waxes under consideration according to the invention have a number-average molecular mass of between 300 and 10 000 g/mol and preferably between 400 and 3000 g/mol.

As microwaxes that may be used in the compositions according to the invention, mention may be made especially of:

- carnauba microwaxes, such as the product sold under the name MicroCare 350[®] by the company Micro Powders,

- synthetic microwaxes, such as the product sold under the name MicroEase 114S[®] by the company Micro Powders,

- microwaxes formed from a mixture of carnauba wax and polyethylene wax, such as the products sold under the names MicroCare 300[®] and 310[®] by the company Micro Powders,

- microwaxes formed from a mixture of carnauba wax and synthetic wax, such as the product sold under the name MicroCare 325[®] by the company Micro Powders,

- polyethylene microwaxes such as the products sold under the names MicroPoly 200[®], 220[®], 220L[®] and 250S[®] by the company Micro Powders, and those sold under the name Cerapure H5-C by the company Shamrock, and

- polypropylene microwaxes, such as the product sold under the name Mattewax by the company Micro Powders.

Carnauba microwaxes are most particularly suitable for use in the invention, and especially those sold by Micro Powders under the name MicroCare.

Preferably, a composition in accordance with the invention comprises at least one carnauba microwax, for example the product sold under the name MicroCare 350[®] by the company Micro Powders.

5 A composition according to the invention may especially comprise a content of microwax of between 0.1% and 15% by weight, in particular between 2% and 12% by weight and more particularly between 5% and 10% by weight relative to the total weight of the composition.

In the compositions according to the invention, the sunflower oil is present in a form combined with at least one volatile organic solvent, in particular at least one volatile
10 hydrocarbon-based solvent.

Volatile hydrocarbon-based oil, also known as volatile hydrocarbon-based solvent

The term "oil" means a fatty substance that is liquid at room temperature and at
15 atmospheric pressure.

For the purposes of the invention, a volatile oil has, at room temperature (25°C) and atmospheric pressure (760 mmHg), a vapour pressure ranging from 0.02 mmHg to 300 mmHg (2.66 Pa to 40 000 Pa) and better still ranging from 0.1 mmHg to 90 mmHg (13 Pa to 12 000 Pa). The non-volatile oils then correspond to a vapour pressure of
20 less than 0.02 mmHg (2.66 Pa) and better still less than 10^{-3} mmHg (0.13 Pa).

The term "hydrocarbon-based oil" means an oil formed essentially from, or even constituted of, carbon and hydrogen atoms, and optionally oxygen and nitrogen atoms, and not containing any silicon or fluorine atoms. It may contain alcohol, ester, ether, carboxylic acid, amine and/or amide groups.

25 The volatile hydrocarbon-based oils (also known as solvents) may be chosen from hydrocarbon-based oils containing from 8 to 16 carbon atoms, and especially branched C₈-C₁₆ alkanes, for instance C₈-C₁₆ isoalkanes of petroleum origin (also known as isoparaffins), for instance isododecane (also known as 2,2,4,4,6-pentamethylheptane), isodecane and isohexadecane, and for example the oils sold under the trade names Isopar
30 or Permethyl, branched C₈-C₁₆ esters and isohexyl neopentanoate, and mixtures thereof. Preferably, the volatile hydrocarbon-based oil is chosen from volatile hydrocarbon-based

oils containing from 8 to 16 carbon atoms, and mixtures thereof, in particular from isododecane, isodecane, isohexadecane and is especially isododecane.

Mention may also be made of volatile linear alkanes comprising from 8 to 16 carbon atoms, in particular from 10 to 15 carbon atoms and more particularly from 11 to 13 carbon atoms, for instance n-dodecane (C₁₂) and n-tetradecane (C₁₄) sold by Sasol under the respective references Parafol 12-97 and Parafol 14-97, and also mixtures thereof, the undecane-tridecane mixture, mixtures of n-undecane (C₁₁) and of n-tridecane (C₁₃) obtained in Examples 1 and 2 of patent application WO 2008/155 059 from the company Cognis, and mixtures thereof.

The volatile hydrocarbon-based solvent is preferably chosen from volatile hydrocarbon-based oils containing from 8 to 16 carbon atoms, and mixtures thereof.

Advantageously, it is at least isododecane.

Advantageously, the volatile hydrocarbon-based solvent under consideration according to the invention is a mixture of isododecane and isohexadecane.

Preferably, this mixture is formed in an isododecane/isohexadecane weight ratio ranging from 0.2 to 2, better still from 0.3 to 1.5.

Advantageously, a composition according to the invention comprises from 10% to 60% by weight and in particular from 15% to 40% by weight of volatile hydrocarbon-based solvent(s) relative to the total weight of the composition.

Needless to say, this volatile hydrocarbon-based solvent or mixture of solvents may be combined with other non-volatile hydrocarbon-based solvents and/or volatile and non-volatile silicone solvents as defined below.

According to one embodiment variant, a composition according to the invention may also comprise at least one volatile silicone oil.

Volatile silicone oil, also known as volatile silicone solvent

The term "silicone oil" means an oil comprising at least one silicon atom, and especially comprising Si-O groups.

The volatile silicone oil that may be used in the invention may be chosen from silicone oils with a flash point ranging from 40°C to 150°C, preferably with a flash point of greater than 55°C and less than or equal to 105°C, and preferentially ranging from 65°C to 95°C. The flash point is measured in particular according to standard ISO 3679.

The volatile silicone oil may be chosen from linear or cyclic silicone oils, such as linear or cyclic polydimethylsiloxanes (PDMSs) containing from 3 to 7 silicon atoms.

5 Volatile silicone oils that may be mentioned include linear volatile silicone oils such as hexamethyldisiloxane, octamethyltrisiloxane, decamethyltetrasiloxane, tetradecamethylhexasiloxane, hexadecamethylheptasiloxane and dodecamethylpentasiloxane.

Volatile cyclic silicone oils that may be mentioned include hexamethylcyclotrisiloxane, octamethylcyclotetrasiloxane, decamethylcyclopentasiloxane and dodecamethylcyclohexasiloxane.

10 Advantageously, it is cyclohexadimethylsiloxane (D6).

Advantageously, a composition according to the invention comprises from 0.1% to 25% by weight, preferably from 5% to 20% by weight and in particular from 8% to 18% by weight of volatile silicone solvent(s) relative to its total weight.

15 According to a preferred variant, a composition according to the invention comprises a volatile hydrocarbon-based solvent(s)/volatile silicone solvent(s) weight ratio of greater than 0.5, in particular greater than or equal to 1, for example between 1 and 5 and better still between 1.2 and 3.5. This weight ratio may especially be greater than 3.

20 Advantageously, a composition according to the invention comprises a total content of volatile hydrocarbon-based and silicone oils of greater than 10% by weight, preferably ranging from 15% to 60% by weight, especially from 20% to 55% by weight, preferably from 25% to 50% by weight and more preferentially 30% to 45% by weight, relative to its total weight.

25 A composition according to the invention may also advantageously comprise at least one polymer chosen from polymers (A) derived from the (co)polymerization of at least one at least C₄ alkene monomer, liposoluble film-forming polymers (B) and semicrystalline polymers (C).

Liposoluble film-forming polymer

30 A liposoluble film-forming polymer (B) is a polymer that is soluble in an oily phase comprising organic solvents or oils.

For the purposes of the invention, the term “film-forming polymer” means a polymer that is capable, by itself or in the presence of an auxiliary film-forming agent, of forming a macroscopically continuous deposit, and preferably a cohesive deposit, and even better still a deposit whose cohesion and mechanical properties are such that said deposit
5 can be isolated and manipulated individually, for example when said deposit is prepared by pouring onto a non-stick surface such as a Teflon-coated or silicone-coated surface.

Advantageously, this liposoluble film-forming polymer is a vinyl ester copolymer.

Vinyl ester copolymers are thus most particularly suitable for use in the
10 invention (the vinyl group being directly linked to the oxygen atom of the ester group and the vinyl ester containing a saturated, linear or branched hydrocarbon-based radical of 1 to 19 carbon atoms, linked to the carbonyl of the ester group) and of at least one other monomer which may be a vinyl ester (other than the vinyl ester already present), an α -olefin (containing from 8 to 28 carbon atoms), an alkyl vinyl ether (in which the alkyl
15 group comprises from 2 to 18 carbon atoms) or an allyl or methallyl ester (containing a saturated, linear or branched hydrocarbon-based radical of 1 to 19 carbon atoms, linked to the carbonyl of the ester group).

These copolymers may be crosslinked with the aid of crosslinking agents, which may be either of the vinyl type or of the allylic or methallylic type, such as
20 tetraallyloxyethane, divinylbenzene, divinyl octanedioate, divinyl dodecanedioate and divinyl octadecanedioate.

Examples of these copolymers that may be mentioned include the following copolymers: vinyl acetate/allyl stearate, vinyl acetate/vinyl laurate, vinyl acetate/vinyl stearate, vinyl acetate/octadecene, vinyl acetate/octadecyl vinyl ether, vinyl
25 propionate/allyl laurate, vinyl propionate/vinyl laurate, vinyl stearate/1-octadecene, vinyl acetate/1-dodecene, vinyl stearate/ethyl vinyl ether, vinyl propionate/cetyl vinyl ether, vinyl stearate/allyl acetate, vinyl 2,2-dimethyloctanoate/vinyl laurate, allyl 2,2-dimethylpentanoate/vinyl laurate, vinyl dimethylpropionate/vinyl stearate, allyl dimethylpropionate/vinyl stearate, vinyl propionate/vinyl stearate, crosslinked with 0.2%
30 divinylbenzene, vinyl dimethylpropionate/vinyl laurate, crosslinked with 0.2% divinylbenzene, vinyl acetate/octadecyl vinyl ether, crosslinked with 0.2% tetraallyloxyethane, vinyl acetate/allyl stearate, crosslinked with 0.2% divinylbenzene,

vinyl acetate/1-octadecene crosslinked with 0.2% divinylbenzene, and allyl propionate/allyl stearate, crosslinked with 0.2% divinylbenzene.

Copolymers that may be more particularly considered include those resulting from the copolymerization of vinyl esters containing from 9 to 22 carbon atoms or of alkyl acrylates or methacrylates, and alkyl radicals containing from 10 to 20 carbon atoms.

Such copolymers may be chosen especially from copolymers of polyvinyl stearate, polyvinyl stearate crosslinked with the aid of divinylbenzene, of diallyl ether or of diallyl phthalate, copolymers of polystearyl (meth)acrylate, polyvinyl laurate and polylauryl (meth)acrylate, it being possible for these poly(meth)acrylates to be crosslinked with the aid of ethylene glycol dimethacrylate or tetraethylene glycol dimethacrylate.

These copolymers may have a weight-average molecular weight ranging from 2000 to 500 000 and preferably ranging from 4000 to 200 000.

The vinyl ester copolymer may be chosen advantageously from vinyl acetate/allyl stearate copolymer (sold especially under the name Mexomer PQ by Chimex) and polyvinyl laurate (sold especially under the name Mexomer PP by Chimex), and mixtures thereof.

Advantageously, a composition according to the invention comprises from 1% to 20% by weight, in particular from 2% to 10% by weight, for example from 2.5% to 5% by weight, of liposoluble film-forming polymer relative to its total weight.

20

Semi-crystalline polymer (SCP)

The cosmetic composition according to the invention may comprise at least one semi-crystalline polymer (C).

Preferably, the semi-crystalline polymer has an organic structure, and a melting point of greater than or equal to 30°C.

For the purposes of the invention, the term “*semi-crystalline polymer*” means polymers comprising a crystallizable portion and an amorphous portion and having a first-order reversible change of phase temperature, in particular of melting point (solid-liquid transition). The crystallizable part is either a side chain (or pendent chain) or a block in the backbone.

30

When the crystallizable part of the semi-crystalline polymer is a block of the polymer backbone, this crystallizable block has a chemical nature different from that of the

amorphous blocks; in this case, the semi-crystalline polymer is a block copolymer, for example of the diblock, triblock or multiblock type. When the crystallizable portion is a chain that is pendent on the backbone, the semicrystalline polymer may be a homopolymer or a copolymer.

5 The melting point of the semicrystalline polymer is preferably less than 120°C.

 The melting point of the semi-crystalline polymer is preferably greater than or equal to 40°C and less than 85°C.

 The semi-crystalline polymer(s) according to the invention are solid at room temperature (25°C) and atmospheric pressure (760 mmHg), with a melting point of greater
10 than or equal to 30°C. The melting point values correspond to the melting point measured using a differential scanning calorimeter (DSC), such as the calorimeter sold under the name DSC 30 by the company Mettler, with a temperature rise of 5°C or 10°C per minute. The melting point under consideration is the point corresponding to the temperature of the most endothermic peak in the thermogram.

15 Besides the crystallizable chains or blocks, the blocks of the polymers are amorphous. For the purposes of the invention, the term "*crystallizable chain or block*" means a chain or block which, if it were alone, would change from the amorphous state to the crystalline state reversibly, depending on whether the temperature is above or below the melting point. For the purposes of the invention, a chain is a group of atoms, which are
20 pendent or lateral relative to the polymer backbone. A "block" is a group of atoms belonging to the backbone, this group constituting one of the repeating units of the polymer.

 The crystallizable blocks or chains of the semi-crystalline polymers may represent at least 30% and better still at least 40% of the total weight of each polymer. The
25 semi-crystalline polymers bearing crystallizable side chains are homopolymers or copolymers. The semi-crystalline polymers of the invention bearing crystallizable blocks are block or multiblock copolymers. They may be obtained by polymerizing a monomer bearing reactive (or ethylenic) double bonds or by polycondensation. When the polymers of the invention are polymers bearing crystallizable side chains, these side chains are
30 advantageously in random or statistical form.

 The semi-crystalline polymers of the invention may be of synthetic origin.

 In particular, the semi-crystalline polymer may be chosen from:

- homopolymers and copolymers comprising units resulting from the polymerization of one or more monomers bearing crystallizable hydrophobic side chain(s),
- polymers bearing in the backbone at least one crystallizable block,
- polycondensates of aliphatic or aromatic or aliphatic/aromatic polyester type,
- 5 - copolymers of ethylene and propylene prepared via metallocene catalysis, and
- acrylate/silicone copolymers.

The semi-crystalline polymers that may be used in the invention may be chosen in particular from:

- block copolymers of polyolefins of controlled crystallization, whose
10 monomers are described in EP 0 951 897,
- polycondensates, in particular of aliphatic or aromatic or aliphatic/aromatic polyester type,
- copolymers of ethylene and propylene prepared via metallocene catalysis,
- homopolymers or copolymers bearing at least one crystallizable side chain
15 and homopolymers or copolymers bearing in the backbone at least one crystallizable block, such as those described in document US 5 156 911, such as the (C₁₀-C₃₀)alkyl polyacrylates corresponding to the Intelimer[®] products from the company Landec described in the brochure *Intelimer[®] Polymers*, Landec IP22 (Rev. 4-97), for example the product Intelimer[®] IPA 13-6 from the company Landec, which is a polystearyl acrylate
20 with a molecular weight of about 145 000 and a melting point of 49°C,
- homopolymers or copolymers bearing at least one crystallizable side chain, in particular containing fluoro group(s), as described in document WO 01/19333,
- acrylate/silicone copolymers, such as copolymers of acrylic acid and of stearyl acrylate bearing polydimethylsiloxane grafts, copolymers of stearyl methacrylate
25 bearing polydimethylsiloxane grafts, copolymers of acrylic acid and of stearyl methacrylate bearing polydimethylsiloxane grafts, copolymers of methyl methacrylate, butyl methacrylate, 2-ethylhexyl acrylate and stearyl methacrylate bearing polydimethylsiloxane grafts. Mention may be made in particular of the copolymers sold by the company Shin-Etsu under the names KP-561 (CTFA name: acrylates/dimethicone),
30 KP-541 (CTFA name: acrylates/dimethicone and isopropyl alcohol), KP-545 (CTFA name: acrylates/dimethicone and cyclopentasiloxane),
- and mixtures thereof.

In the context of the present invention, as particularly advantageous semi-crystalline polymers, mention may be made of poly(C₁₀-C₃₀)alkyl acrylates, for example the product sold under the name Intelimer IPA 13-1 NG by the company Air Products & Chemicals.

5 Advantageously, a composition according to the invention comprises from 1% to 10% by weight and in particular from 2% to 5% by weight of semi-crystalline polymer(s) relative to its total weight.

According to an embodiment variant, a composition according to the invention may comprise a mixture of polymers (B) and (C).

10

Polymer (A)

A polymer (A) according to the invention advantageously has a weight-average molecular mass Mw of greater than or equal to 750 g/mol, advantageously between 800 and 10 000 g/mol, more preferentially between 900 and 5000 g/mol.

15 A polymer (A) is preferably derived from the (co)polymerization of at least one linear and/or branched C₄-C₁₂, preferably C₄, C₁₀ or C₁₂, preferably C₄, alkene monomer.

Preferably, polymer (A) according to the invention is at least partly hydrogenated, preferentially totally hydrogenated.

20 A polymer (A) according to the invention advantageously contains at least 10 monomers, preferentially between 12 and 50 monomers and even more preferentially between 15 and 40 monomers.

25 Preferably, said polymer (A) comprises at least one monomer chosen from the four isomers of butene structure, namely 1-butene, (Z)-2-butene, (E)-2-butene and 2-methyl-1-propene (or isobutene), and mixtures thereof. The term "poly(iso)butene" covers polymers derived from at least any one of these monomers in the rest of the present description.

Preferably, said polymer (A) comprises at least one 2-methyl-1-propylene monomer.

30 According to a particular embodiment, said polymer (A) is derived from the copolymerization of at least two of these four isomers. Preferably, one of these two isomers is 2-methyl-1-propene.

According to a particular embodiment, said resulting polymer (A) comprises a mixture of poly-1-butene and 2-methyl-1-propene.

According to another embodiment, said polymer is a poly-1-butylene homopolymer.

5 Preferably, said polymer (A) is chosen from poly(iso)butene, polydecene and polydodecene, and mixtures thereof, optionally at least partially hydrogenated, and is preferably poly(iso)butene.

10 Polymer (A) according to the invention advantageously has at 100°C a kinematic viscosity of greater than 1000 centistokes, preferably between 2000 and 8000 centistokes, more preferentially between 2500 and 5000 centistokes.

Polymer (A) according to the invention has at 25°C a static viscosity of greater than or equal to 20 000 mPa.s, preferably greater than or equal to 65 000 mPa.s, preferably greater than or equal to 350 000 mPa.s, for example inclusively between 25 000 and 800
15 000 mPa.s and better still between 400 000 and 600 000 mPa.s. Such a viscosity may be measured using an RS75 rheometer sold by the company Haake, equipped with a plate or cone 60 mm in diameter with a 2° incline.

Polymer (A) used in the context of the present invention may be chosen, for example, from Indopol H-100, Indopol H-300 and Indopol H-1500 from the company
20 Amoco, and Parleam V, Parleam HV and Parleam SV from NOF Corporation. Indopol H-1500 or Parleam SV will preferentially be used.

The total content of polymer(s) (A) according to the invention is between 2% and 20% by weight, in particular between 5% and 15% by weight, for example between 8% and 12% by weight, relative to the total weight of the composition.

25

Non-volatile oil

According to a particular embodiment, a composition according to the invention may also comprise at least one non-volatile oil.

The term "non-volatile oil" means an oil that remains on the skin or the keratin
30 fibre at room temperature and pressure. More specifically, a non-volatile oil has an evaporation rate strictly less than 0.01 mg/cm²/min.

To measure this evaporation rate, 15 g of oil or of oil mixture to be tested are placed in a crystallizing dish 7 cm in diameter, which is placed on a balance in a large chamber of about 0.3 m³ that is temperature-regulated, at a temperature of 25°C, and hygrometry-regulated, at a relative humidity of 50%. The liquid is allowed to evaporate
5 freely, without stirring it, while providing ventilation by means of a fan (Papst-Motoren, reference 8550 N, rotating at 2700 rpm) placed in a vertical position above the crystallizing dish containing said oil or said mixture, the blades being directed towards the crystallizing dish, 20 cm away from the bottom of the crystallizing dish. The mass of oil remaining in the crystallizing dish is measured at regular intervals. The evaporation rates are expressed
10 in mg of oil evaporated per unit of area (cm²) and per unit of time (minutes).

The non-volatile hydrocarbon-based oils that are suitable for use in the present invention may be chosen in particular from:

- hydrocarbon-based oils of plant origin, such as triglycerides formed from
15 fatty acid esters of glycerol, the fatty acids of which may have chain lengths ranging from C₄ to C₂₈, these fatty acids possibly being linear or branched, and saturated or unsaturated; these oils are in particular wheatgerm oil, sunflower oil, grapeseed oil, sesame oil, corn oil, apricot oil, castor oil, shea oil, avocado oil, olive oil, soybean oil, sweet almond oil, rapeseed oil, cottonseed oil, hazelnut oil, macadamia oil, jojoba oil, palm oil, alfalfa oil,
20 poppy oil, pumpkin oil, sesame seed oil, marrow oil, blackcurrant oil, evening primrose oil, millet oil, barley oil, quinoa oil, rye oil, safflower oil, candlenut oil, passion flower oil and musk rose oil; or alternatively caprylic/capric acid triglycerides such as those sold by the company Stéarineries Dubois or those sold under the names Miglyol 810®, 812® and 818® by the company Sasol;

25 - synthetic ethers containing from 10 to 40 carbon atoms;

- linear or branched hydrocarbons of mineral or synthetic origin other than the polymers according to the invention, such as petroleum jelly, polydecenes and squalane, and mixtures thereof;

- synthetic esters such as the oils of formula R₁COOR₂ in which R₁ represents
30 the linear or branched fatty acid residue containing from 1 to 40 carbon atoms and R₂ represents an in particular branched hydrocarbon-based chain containing from 1 to 40 carbon atoms, on condition that R₁ + R₂ ≥ 10, for instance purcellin oil (cetostearyl

octanoate), isopropyl myristate, isopropyl palmitate, C12 to C15 alkyl benzoate, hexyl laurate, diisopropyl adipate, isononyl isononanoate, 2-ethylhexyl palmitate, isostearyl isostearate, alkyl or polyalkyl octanoates, decanoates or ricinoleates such as propylene glycol dioctanoate; hydroxylated esters such as isostearate lactate and diisostearyl malate;
5 and pentaerythritol esters;

- fatty alcohols that are liquid at room temperature, with a branched and/or unsaturated carbon-based chain containing from 12 to 26 carbon atoms, for instance octyldodecanol, isostearyl alcohol, oleyl alcohol, 2-hexyldecanol, 2-butyloctanol and 2-undecylpentadecanol;

10 - higher fatty acids such as oleic acid, linoleic acid or linolenic acid, and mixtures thereof.

The non-volatile silicone oils that are suitable for use in the present invention may be chosen in particular from:

15 non-volatile polydimethylsiloxanes (PDMSs), polydimethylsiloxanes comprising alkyl or alkoxy groups, that are pendent and/or at the end of a silicone chain, the groups each containing from 2 to 24 carbon atoms, phenyl silicones, for instance phenyl trimethicones, phenyl dimethicones, phenyltrimethylsiloxydiphenylsiloxanes, diphenyl dimethicones, diphenylmethyldiphenyltrisiloxanes and 2-phenylethyl
20 trimethylsiloxy silicates.

The total content of non-volatile oil(s), which are preferably hydrocarbon-based, in the composition in accordance with the invention ranges from 0.01% to 10% by weight, in particular from 0.1% to 8% by weight and preferably from 0.25% to 5% by
25 weight relative to the total weight of the composition.

According to a preferred embodiment, a composition according to the invention comprises less than 5% by weight of non-volatile oil(s) relative to the total weight of the composition.

30 **Pasty fatty substances**

According to a particular embodiment, a composition according to the invention may also comprise at least one pasty fatty substance.

For the purposes of the present invention, the term “pasty fatty substance” means a lipophilic fatty compound with a reversible solid/liquid change of state, which comprises at a temperature of 23°C a liquid fraction and a solid fraction.

In other words, the starting melting point of the pasty compound may be less than 23°C. The liquid fraction of the pasty compound measured at 23°C may represent from 9% to 97% by weight of the compound. This liquid fraction at 23°C preferably represents between 15% and 85% and more preferably between 40% and 85% by weight.

Preferably, the pasty fatty substances have an end melting point of less than 60°C.

Preferably, the pasty fatty substances have a hardness of less than or equal to 6 MPa.

Preferably, the pasty fatty substances have, in the solid state, a crystalline organization, which is visible by X-ray scattering characterization.

Within the context of the invention, the melting point corresponds to the temperature of the most endothermic peak observed in thermal analysis (DSC) as described in the standard ISO 11357-3; 1999. The melting point of a pasty substance or of a wax may be measured using a differential scanning calorimeter (DSC), for example the calorimeter sold under the name DSC Q2000 by the company TA Instruments.

As regards the measurement of the melting point and the determination of the end melting point, the sample preparation and measurement protocols are as follows:

A sample of 5 mg of pasty fatty substance, preheated to 80°C and withdrawn with magnetic stirring using a spatula that is also heated, is placed in a hermetic aluminium capsule, or a crucible. Two tests are performed to ensure the reproducibility of the results.

The measurements are performed on the abovementioned calorimeter. The oven is flushed with nitrogen. Cooling is performed by an RCS 90 heat exchanger. The sample is then subjected to the following protocol: it is first placed at a temperature of 20°C, and then subjected to a first temperature rise passing from 20°C to 80°C, at a heating rate of 5°C/minute, then is cooled from 80°C to -80°C at a cooling rate of 5°C/minute and finally subjected to a second temperature rise passing from -80°C to 80°C at a heating rate of 5°C/minute. During the second temperature rise, the variation in the difference between

the power absorbed by the empty crucible and the crucible containing the sample of pasty substance or wax as a function of the temperature is measured. The melting point of the compound is the value of the temperature corresponding to the top of the peak of the curve representing the variation in the difference in power absorbed as a function of the temperature.

The end melting point corresponds to the temperature at which 95% of the sample has melted.

The liquid fraction by weight of the pasty compound at 23°C is equal to the ratio of the heat of fusion consumed at 23°C to the heat of fusion of the pasty compound.

The heat of fusion of the pasty compound is the heat consumed by the compound in order to pass from the solid state to the liquid state. The pasty compound is said to be in the solid state when all of its mass is in crystalline solid form. The pasty compound is said to be in the liquid state when all of its mass is in liquid form.

The heat of fusion of the pasty compound is equal to the integral of the entire melting curve obtained using the abovementioned colorimeter, with a temperature rise of 5°C or 10°C/minute, according to standard ISO 11357-3:1999. The heat of fusion of the pasty compound is the amount of energy required to make the compound change from the solid state to the liquid state. It is expressed in J/g.

The heat of fusion consumed at 23°C is the amount of energy absorbed by the sample to change from the solid state to the state that it has at 23°C, formed from a liquid fraction and a solid fraction.

The liquid fraction of the pasty compound measured at 32°C preferably represents from 30% to 100% by weight of the compound, preferably from 50% to 100%, more preferably from 60% to 100% by weight of the compound. When the liquid fraction of the pasty compound measured at 32°C is equal to 100%, the temperature of the end of the melting range of the pasty compound is less than or equal to 32°C.

The liquid fraction of the pasty compound measured at 32°C is equal to the ratio of the heat of fusion consumed at 32°C to the heat of fusion of the pasty compound. The heat of fusion consumed at 32°C is calculated in the same way as the heat of fusion consumed at 23°C.

As regards the measurement of the hardness, the sample preparation and measurement protocols are as follows:

The pasty fatty substance is placed in a mould 75 mm in diameter, which is filled to about 75% of its height. In order to overcome the thermal history and to control the crystallization, the mould is placed in a Vötsch VC 0018 programmable oven, where it is first placed at a temperature of 80°C for 60 minutes, then cooled from 80°C to 0°C at a cooling rate of 5°C/minute, and then left at the stabilized temperature of 0°C for 60 minutes, and then subjected to a temperature rise ranging from 0°C to 20°C, at a heating rate of 5°C/minute, and then left at the stabilized temperature of 20°C for 180 minutes.

The compression force measurement is taken using a TA/TX2i texturometer from Swantech. The spindle used is chosen according to the texture:

- cylindrical steel spindle 2 mm in diameter for very rigid starting materials;
- cylindrical steel spindle 12mm in diameter for sparingly rigid starting materials.

The measurement comprises three steps: a first step after automatic detection of the surface of the sample, where the spindle moves at a measuring speed of 0.1 mm/s, and penetrates into the pasty fatty substance to a penetration depth of 0.3 mm, the software notes the maximum force value reached; a second "relaxation" step where the spindle remains at this position for one second and the force is noted after 1 second of relaxation; finally, a third "withdrawal" step in which the spindle returns to its initial position at a speed of 1 mm/s, and the probe withdrawal energy (negative force) is noted.

The hardness value measured during the first step corresponds to the maximum compression force measured in newtons divided by the area of the texturometer cylinder expressed in mm² in contact with the pasty fatty substance. The hardness value obtained is expressed in megapascals or MPa.

The pasty fatty substance is preferably chosen from synthetic compounds and compounds of plant origin. A pasty compound may be obtained by the synthesis from starting materials of plant origin.

The pasty compound is advantageously chosen from:

- lanolin and derivatives thereof,

- petroleum jelly, in particular the product whose INCI name is petrolatum and which is sold under the name Ultima White PET USP by the company Penreco,

- polyol ethers chosen from polyalkylene glycol pentaerythrityl ethers, fatty alcohol ethers of sugars, and mixtures thereof, the polyethylene glycol pentaerythrityl ether comprising five oxyethylene (5 OE) units (CTFA name: PEG-5 Pentaerythrityl Ether),
5 polypropylene glycol pentaerythrityl ether comprising five oxypropylene (5 OP) units (CTFA name: PEG-5 Pentaerythrityl Ether) and mixtures thereof, and more especially the mixture PEG-5 Pentaerythrityl Ether, PPG-5 Pentaerythrityl Ether and soybean oil, sold under the name Lanolide by the company Vevy, which is a mixture in which the
10 constituents are in a 46/46/8 weight ratio: 46% PEG-5 pentaerythrityl ether, 46% PPG-5 pentaerythrityl ether and 8% soybean oil,

- polymeric or non-polymeric silicone compounds,

- polymeric or non-polymeric fluoro compounds,

- vinyl polymers, especially:

15 - olefin homopolymers and copolymers,

- hydrogenated diene homopolymers and copolymers,

- linear or branched oligomers, homopolymers or copolymers of alkyl (meth)acrylates preferably containing a C₈-C₃₀ alkyl group,

20 - oligomers, homopolymers and copolymers of vinyl esters containing C₈-C₃₀ alkyl groups,

- oligomers, homopolymers and copolymers of vinyl ethers containing C₈-C₃₀ alkyl groups,

liposoluble polyethers resulting from the polyetherification between one or more C₂-C₁₀₀ and preferably C₂-C₅₀ diols,

25 esters, and/or mixtures thereof.

The pasty compound is preferably a polymer, especially a hydrocarbon-based polymer.

30 Among the liposoluble polyethers that are particularly preferred are copolymers of ethylene oxide and/or of propylene oxide with C₆-C₃₀ long-chain alkylene oxides, more preferably such that the weight ratio of the ethylene oxide and/or of propylene oxide to the alkylene oxides in the copolymer is from 5:95 to 70:30. In this

family, mention will be made especially of copolymers such that the long-chain alkylene oxides are arranged in blocks having an average molecular weight from 1000 to 10 000, for example a polyoxyethylene/polydodecyl glycol block copolymer such as the ethers of dodecanediol (22 mol) and of polyethylene glycol (45 OE) sold under the brand name
5 Elfacos ST9 by Akzo Nobel.

Among the esters, the following are especially preferred:

- esters of a glycerol oligomer, especially diglycerol esters, in particular condensates of adipic acid and of glycerol, for which some of the hydroxyl groups of the
10 glycerols have reacted with a mixture of fatty acids such as stearic acid, capric acid, stearic acid and isostearic acid, and 12-hydroxystearic acid, preferably such as bis-diglyceryl polyacyladipate-2 sold under the brand name Softisan 649 by the company Sasol,
 - the arachidyl propionate sold under the brand name Waxenol 801 by Alzo,
 - phytosterol esters,
 - 15 - fatty acid triglycerides and derivatives thereof, for instance triglycerides of fatty acids, which are especially C10-C18, and partially or totally hydrogenated such as those sold under the reference Softisan 100 by the company Sasol,
 - pentaerythritol esters,
 - and mixtures thereof.

20 The esters of diol dimer and of diacid dimer, where appropriate esterified on the free alcohol or acid function(s) thereof with acid or alcohol radicals, especially dimer dilinoleate esters; such esters may be chosen especially from the esters having the following INCI nomenclature: bis-behenyl/isostearyl/phytosteryl dimer dilinoleyl dimer dilinoleate (Plandool G), phytosteryl/isostearyl/cetyl/stearyl/behenyl dimer dilinoleate
25 (Plandool H or Plandool S), and mixtures thereof,

mango butter, such as the product sold under the reference Lipex 203 by the company AarhusKarlshamn,

shea butter, in particular the product whose INCI name is Butyrospermum parkii Butter, such as the product sold under the reference Sheasoft® by the company
30 Aarhuskarlshamn,
and mixtures thereof.

Among the pasty compounds, bis-behenyl/isostearyl/phytosteryl dimer dilinoleyl, bis(diglyceryl) poly(2-acyladipate), hydrogenated castor oil dimer dilinoleate, for example Risocast DA-L sold by Kokyu Alcohol Kogyo, and hydrogenated castor oil isostearate, for example Salacos HCIS (V-L) sold by Nisshin Oil, mango butter, shea butter, and vinylpyrrolidone/eicosene copolymers, or a mixture thereof, will preferably be chosen.

A composition according to the invention is preferably free of pasty fatty substances. However, a composition according to the invention may comprise one or more pasty fatty substances in a total content of greater than or equal to 0.01% by weight relative to the total weight of the composition, for example between 0.1% and 10% by weight relative to the total weight of the composition.

Lipophilic gelling agent

A composition according to the invention may advantageously comprise at least one lipophilic gelling agent.

The gelling agent(s) that may be used may be organic or mineral, polymeric or molecular lipophilic gelling agents.

Mineral lipophilic gelling agents that may be mentioned include clays and fumed silica optionally subjected to a hydrophobic surface treatment, the particle size of which is less than 1 μm .

The polymeric organic lipophilic gelling agents are, for example:

- partially or totally crosslinked elastomeric organopolysiloxanes, of three-dimensional structure, such as those sold under the names KSG6®, KSG16® and KSG18® by the company Shin-Etsu, Trefil E-505C® and Trefil E-506C® by the company Dow Corning, Gransil SR-CYC®, SR DMF10®, SR-DC556®, SR 5CYC Gel®, SR DMF 10 Gel® and SR DC 556 Gel® by the company Grant Industries, and SF 1204® and JK 113® by the company General Electric;

- ethylcellulose, for instance the product sold under the name Ethocel® by the company Dow Chemical;

- polycondensates of polyamide type resulting from the condensation between (α) at least one acid chosen from dicarboxylic acids comprising at least 32 carbon atoms such as fatty acid dimers and (β) an alkylenediamine and in particular ethylenediamine, in

which the polyamide polymer comprises at least one carboxylic acid end group esterified or amidated with at least one monoalcohol or monoamine comprising from 12 to 30 saturated and linear carbon atoms, and in particular ethylenediamine/stearyl dilinoleate copolymers such as the product sold under the name Uniclear 100 VG® by the company
5 Arizona Chemical;

- silicone polyamides of the polyorganosiloxane type such as those described in documents US-A-5 874 069, US-A-5 919 441, US-A-6 051 216 and US-A-5 981 680, for instance those sold under the reference Dow Corning 2-8179 and Dow Corning 2-8178 Gellant by the company Dow Corning;

10 - galactomannans comprising from one to six and in particular from two to four hydroxyl groups per saccharide, substituted with a saturated or unsaturated alkyl chain, for instance guar gum alkylated with C₁ to C₆, and in particular C₁ to C₃, alkyl chains, and mixtures thereof;

- block copolymers of “diblock”, “triblock” or “radial” type, of the
15 polystyrene/polyisoprene or polystyrene/polybutadiene type, such as the products sold under the name Luvitol HSB® by the company BASF, of the polystyrene/copoly(ethylene-propylene) type, such as the products sold under the name Kraton® by the company Shell Chemical Co., or of the polystyrene/copoly(ethylene-butylene) type, and mixtures of triblock and radial (star) copolymers in isododecane, such as those sold by the company
20 Penreco under the name Versagel®, for instance the mixture of butylene/ethylene/styrene triblock copolymer and of ethylene/propylene/styrene star copolymer in isododecane (Versagel M 5960).

According to a particular embodiment, a composition according to the
25 invention may comprise at least one dyestuff chosen from one or more pulverulent material(s), preferably metal oxides, and in particular iron oxides.

Dyestuffs

The compositions in accordance with the invention may comprise at least one
30 dyestuff.

This (or these) dyestuff(s) are preferably chosen from pulverulent substances, liposoluble dyes and water-soluble dyes, and mixtures thereof.

Preferably, the compositions according to the invention comprise at least one pulverulent dyestuff. The pulverulent dyestuffs may be chosen from pigments and nacles, and preferably from pigments.

The pigments may be white or coloured, mineral and/or organic, and coated or uncoated. Among the mineral pigments, mention may be made of metal oxides, in particular titanium dioxide, optionally surface-treated, zirconium, zinc or cerium oxide, and also iron, titanium or chromium oxide, manganese violet, ultramarine blue, chromium hydrate and ferric blue. Among the organic pigments that may be mentioned are carbon black, pigments of D&C type and lakes based on cochineal carmine or on barium, strontium, calcium or aluminium.

The nacles may be chosen from white nacreous pigments such as mica coated with titanium or with bismuth oxychloride, coloured nacreous pigments such as titanium mica with iron oxides, titanium mica with in particular ferric blue or chromium oxide, titanium mica with an organic pigment of the abovementioned type, and also nacreous pigments based on bismuth oxychloride.

The liposoluble dyes are, for example, Sudan Red, D&C Red 17, D&C Green 6, β -carotene, soybean oil, Sudan Brown, D&C Yellow 11, D&C Violet 2, D&C Orange 5, quinoline yellow and annatto.

Preferably, the pigments contained in the compositions according to the invention are chosen from metal oxides.

These dyestuffs may be present in a content ranging from 0.01% to 30% by weight relative to the total weight of the composition and in particular from 3% to 15% by weight relative to the total weight of the composition.

Preferably, the dyestuff(s) are chosen from one or more metal oxides that are present in a content of greater than or equal to 2% by weight relative to the total weight of the composition, and advantageously inclusively between 3% and 15% by weight relative to the total weight of the composition.

Fillers

The compositions in accordance with the invention may also comprise at least one additional filler other than the microwaxes.

The fillers may be selected from those that are well known to persons skilled in the art and commonly used in cosmetic compositions.

The fillers may be mineral or organic, and lamellar or spherical.

Mention may be made of talc, mica, silica, kaolin, polyamide powders, for instance the Nylon® sold under the name Orgasol® by the company Atochem, poly-β-alanine powders and polyethylene powders, powders of tetrafluoroethylene polymers, for instance Teflon®, lauroyllysine, starch, boron nitride, expanded polymeric hollow microspheres such as those of polyvinylidene chloride/acrylonitrile, for instance the products sold under the name Expancel® by the company Nobel Industrie, acrylic powders such as those sold under the name Polytrap® by the company Dow Corning, polymethyl methacrylate particles and silicone resin microbeads (for example Tospearls® from Toshiba), precipitated calcium carbonate, magnesium carbonate and magnesium hydrocarbonate, hydroxyapatite, hollow silica microspheres (Silica Beads® from Maprecos), glass or ceramic microcapsules, metal soaps derived from organic carboxylic acids having from 8 to 22 carbon atoms and in particular from 12 to 18 carbon atoms, for example zinc, magnesium or lithium stearate, zinc laurate and magnesium myristate.

It may also be hectorite, especially modified hectorite.

It is also possible to use a compound that is capable of swelling on heating, and especially heat-expandable particles such as non-expanded microspheres of vinylidene chloride/acrylonitrile/methyl methacrylate copolymer or of acrylonitrile homopolymer or copolymer, for instance those sold, respectively, under the references Expancel® 820 DU 40 and Expancel® 007WU by the company Akzo Nobel.

The fillers other than the microwax(es) required according to the invention may represent from 0.1% to 15% by weight and in particular from 3% to 10% by weight relative to the total weight of the composition.

Fibres

The compositions in accordance with the invention may also comprise at least one fibre that can improve the lengthening effect.

The term "fibre" should be understood as meaning an object of length L and of diameter D such that L is very much greater than D, D being the diameter of the circle in which the cross section of the fibre is inscribed. In particular, the ratio L/D (or aspect ratio)

is chosen in the range from 3.5 to 2500, in particular from 5 to 500 and more particularly from 5 to 150.

The fibres that may be used in the composition of the invention may be mineral or organic fibres, of synthetic or natural origin. They may be short or long, individual or
5 organized, for example braided, and hollow or solid. They may have any shape and may especially have a circular or polygonal (square, hexagonal or octagonal) cross section depending on the specific application envisaged. In particular, their ends are blunted and/or polished to prevent injury.

In particular, the fibres have a length ranging from 1 μm to 10 mm, in
10 particular from 0.1 mm to 5 mm and more particularly from 0.3 mm to 3.5 mm. Their cross section may be included in a circle with a diameter ranging from 2 nm to 500 μm , in particular ranging from 100 nm to 100 μm and more particularly from 1 μm to 50 μm . The weight or yarn count of fibres is often given in denier or decitex and represents the weight in grams per 9 km of yarn. The fibres according to the invention may in particular have a
15 count chosen within the range from 0.15 to 30 denier and especially from 0.18 to 18 denier.

The fibres that may be used in the composition of the invention may be chosen from rigid or non-rigid fibres, and may be mineral or organic fibres, of synthetic or natural origin.

20 Moreover, the fibres may or may not be surface-treated, may be coated or uncoated, and may be coloured or uncoloured.

As fibres that may be used in the composition according to the invention, mention may be made of non-rigid fibres such as polyamide (Nylon[®]) fibres or rigid fibres such as polyimideamide fibres, for instance those sold under the names Kermel[®] and
25 Kermel Tech[®] by the company Rhodia or poly(p-phenyleneterephthalamide) (or aramid) fibres sold especially under the name Kevlar[®] by the company DuPont de Nemours.

The fibres may be present in the composition according to the invention in a content ranging from 0.01% to 10% by weight, in particular from 0.1% to 5% by weight and more particularly from 0.3% to 3% by weight relative to the total weight of the
30 composition.

Cosmetic additives

The compositions in accordance with the invention may also comprise at least one cosmetic additive.

As cosmetic additives that may be used in the compositions in accordance with the invention, mention may be made especially of antioxidants, preserving agents, 5 fragrances, neutralizers, emollients, thickeners, coalescers, plasticizers, moisturizers and vitamins, and mixtures thereof.

Needless to say, a person skilled in the art will take care to select the optional additional additives and/or the amount thereof such that the advantageous properties of the composition according to the invention are not, or are not substantially, adversely affected 10 by the envisaged addition.

Preferably, the composition according to the invention is a leave-on composition. Advantageously, the composition is a makeup composition and in particular a mascara.

15 **DETAILED DESCRIPTION OF THE APPLICATION ASSEMBLY**

As emerges from the foregoing, the invention is most particularly directed towards proposing an assembly for packaging and applying this composition, which is suitable for heating it and which is not of a nature to substantially impair, in the course of the uses, the cosmetic properties of said composition.

20 This assembly comprises, besides the composition as defined above, at least:

(a) an element for applying this composition; and

(b) heating means for bringing said composition, prior to, simultaneously with or after its application, to a temperature suitable for its deformability.

Such application elements and heating means that may be used with a 25 composition of the invention are advantageously those described in patent application FR 2 996 109.

This packaging and application assembly advantageously comprises a container or reservoir intended for housing the composition for coating keratin fibres.

This composition may then be taken up in the container by immersing the 30 applicator therein. This container may optionally be equipped with a wiper suitable for removing the surplus product taken up by the applicator.

The application element or applicator advantageously comprises means for smoothing and/or separating keratin fibres, such as the eyelashes or the eyebrows, especially in the form of teeth, bristles or other reliefs.

The applicator is thus arranged to apply the composition to the eyelashes or the eyebrows, and may comprise, for example, an application means such as a brush or a comb.

The applicator may also be used for finishing of the makeup, over a region of the eyelashes or eyebrows that is made up or laden with composition.

The applicator may be a brush or a comb.

Preferably, this applicator comprises at least one row of teeth obtained by moulding.

More preferentially, this applicator is a brush comprising a plurality of rows of teeth distributed along a longitudinal axis of the brush, for example distributed in parallel along this axis, and extending radially, inclined relative to each other, about a transverse cross section of said brush.

This applicator may be firmly attached to an element for closing the container containing the composition. This closing element may form a member for gripping the applicator. This gripping member may form a cap to be removably mounted on said container by any suitable means, such as screwing, click-fastening, coupling, etc. Such a container may thus reversibly house said applicator.

It should be noted that, according to another embodiment, the applicator may form a container for the composition. In such a case, a container may, for example, be provided in the gripping member and an internal channel can internally connect this gripping member to the application elements in relief.

Finally, as mentioned previously, the assembly according to the invention also comprises heating means.

Preferably, the heating means are capable of bringing the composition to be applied to a temperature of between 35°C and 100°C and preferably between 40°C and 75°C.

According to a first embodiment, the heating means are formed by a device other than the application element, said assembly then being configured in the form of a

kit. Such a kit may be packaged inside packaging of blister pack type. The heating means may be of the type described in patents US 6 009 884 or US 5 853 010. Other devices may also be used, such as those described especially in patent US 6 220 252.

An advantage of such a configuration is that the makeup product can be
5 packaged in a standard packaging and application assembly, sold:

i) either in combination with a heating device when it is intended to be used according to the invention;

ii) or alone when it is intended to be used without heating.

Preferably, depending on the desired application characteristics, the user will
10 have the possibility either of using the product without heating, or of heating it to obtain curling that is both more pronounced and longer-lasting.

According to a preferred alternative, illustrated in particular in patent application FR 2 996 109, the heating means are combined with the application element.
15 Thus, the bulk and the overall cost of the device are especially substantially reduced. In addition, this configuration offers the possibility with the same tool of both applying the product and curling the eyelashes. The overall time required for applying the makeup is thereby substantially reduced. Such a device also has the advantage of being non-invasive to the user and easy to use, making it possible to conserve the usual action for making up
20 the eyelashes.

The packaging and application assembly 1 represented in Figure 1 comprises a container 2 containing a cosmetic product P to be applied to the eyelashes or the eyebrows, for example mascara, and an applicator intended to take up the product contained in the
25 container and to apply it.

In the illustrated example, the body of the container 2 is open at its top end to receive an end piece 18, the top part of which constitutes the neck 4 of the container and the bottom part of which serves as a wiping member 8. The container and/or the wiping member may be made in another manner, and the container may be made with a neck, for
30 example derived from moulding with the body, the wiping member being introduced into the neck. The applicator comprises a stem 9 which is, in the described example, rectilinear with an axis X, equipped at a first end with an application member 5 and at a second end

10 with a member for closing the container, comprising, for example, a skirt 91 that is threaded inside, so as to screw onto the neck 4 of the container 2. The application member especially comprises a heating element 12 comprising a resistance wire 70.

5 According to a particular embodiment, the heating element 12 is fed via conductors 79, for example extending along the stem 9, connected to an electric power supply module 20 which is, for example, removably attached to the closing member of the container.

The ends 15 of the conductors 79 are equipped, for example, with a connector 97 for connecting to the power supply module 20.

10 The electric power supply module 20 defines with the closing member of the container a surface for gripping the applicator, and comprises a housing 25 for containing a cell or battery. The supply module may also comprise a manual control member for operating the heating element, such as a push button.

15 It is understood that, in the context of the present invention, the weight percentages given for a compound or a family of compounds are always expressed as weight of solids of the compound in question.

20 Throughout the application, the wording "comprising one" or "containing one" means "comprising at least one" or "containing at least one", unless otherwise specified.

The terms "between... and..." and "ranging from... to..." should be understood as being inclusive of the limits, unless otherwise specified.

25 In the description and the examples, the percentages are percentages by weight. The ingredients are mixed in the order and under conditions that are easily determined by a person skilled in the art.

The invention is illustrated in greater detail in the examples and figures that follow, which are given purely as illustrations of the invention.

Description of the figures

30 **Figure 1a** illustrates a packaging and application device 1 comprising a container 2 containing a cosmetic product P to be applied to the eyelashes or the eyebrows,

for example mascara, and an applicator intended to take up the product contained in the container and to apply it.

Figure 1b illustrates in isolation the application element of Figure 1a.

Figure 2 illustrates the curl ($^{\circ}$) measurements taken using a protractor on
5 specimens of false eyelashes on photos taken with a DVM RemoteControl video microscope (optical elements + Kappa video camera).

The first photo illustrates the curl measurement of the specimens of false eyelashes in the absence of mascara. The second photo illustrates the curl measurement of the false eyelashes after application of mascara. The third photo is a magnification of the
10 second photo, which shows in detail the curling characterized by an angle "a" created between the base of the specimen and the line of the average height of the fringe.

Figure 3 illustrates the curl values obtained from T0 (15 minutes after applying the mascara) and then for the following 25 hours. These measurements were taken on specimens of false eyelashes (i) in the absence of application of makeup; (ii) after
15 application of a mascara in accordance with the invention (Mascara 1); (iii) after application of a commercial composition, Maybelline Volume Express WP®; and (iv) after application of an Agnès b heating brush and of a commercial composition Maybelline Volume Express WP®. On the x-axis: Time after first measurement at T0; On the y-axis: curl value ($^{\circ}$).

20

Materials and methods

The protocols used in the examples below are detailed below.

A. Makeup protocol and curl measurement

25

Application of makeup to specimens of false eyelashes

a) Description of the specimens of false eyelashes

The specimens consist of Caucasian hair mounted on an aluminium plate.

These specimens have dimensions of 30 mm \times 30 mm. They are formed
30 especially from 60 strands of hair about 20 mm long which make one return trip (one knot) and are distributed over 20 mm.

They may especially be specimens of reference B486 sold by SP Equation.

b) Protocol of the test in a single action with heating

The makeup is applied in a room in which the humidity and temperature conditions are considered as constant.

5 The mascara is applied using an applicator (brush or comb) connected to a generator. The brush is set at a temperature of 65°C.

The temperature is controlled using a thermal camera. The product is first applied to the brush using a syringe.

10 At the application temperature, the false eyelashes are made up manually underneath by performing 3×10 sweeps of mascara at 2-minute intervals with reuptake of product between each series of 10.

c) Protocol of comparative test 1 in a conventional single action (without heating)/commercial waterproof formulation

15 The makeup is applied in a room in which the humidity and temperature conditions are considered as constant.

The mascara is applied from its original pack: Volume Express Waterproof® from Maybelline.

20 The false eyelashes are made up manually underneath by performing 3×10 sweeps of mascara at 2-minute intervals with reuptake of product between each series of 10.

d) Protocol of the test in two standard actions: Shu Uemura mechanical curler + makeup

25 The makeup is applied in a room in which the humidity and temperature conditions are considered as constant.

The mascara is applied from its original pack: Volume Express Waterproof® from Maybelline.

30 In a first stage, two manual and successive applications of the mechanical curler are performed.

Next, the false eyelashes are made up manually underneath by performing 3×10 sweeps of mascara at 2-minute intervals with reuptake of product between each series of 10.

5 d) Protocol of the test in two standard actions: Agnès B heating curler + makeup

The makeup is applied in a room in which the humidity and temperature conditions are considered as constant.

10 The mascara is applied from its original pack: Volume Express Waterproof® from Maybelline.

In a first stage, 10 manual and successive applications of the Curl Brush® heating curler from Agnès b are performed on the false eyelashes.

The temperature of the heating curler is controlled using a thermal camera.

15 Next, the false eyelashes are made up manually underneath by performing 3×10 sweeps of mascara at 2-minute intervals with reuptake of product between each series of 10.

Measurement of the curl

a) Taking of photos

20 The photos are taken with a DVM Remote Control video microscope (optical elements + Kappa video camera).

Before treating the false eyelashes, a photo is first taken of the naked specimen, i.e. not made up. To do this, it is held vertically using pincers, on a target. The upper and lower faces of the specimen are then marked.

25 The specimen is then made up as indicated above.

Once the specimen has been made up, a new photo is taken. The initial curl corresponds to the value T₀, and is measured 15 minutes after applying the mascara. This initial curl value is obtained by the difference between the angle measured on the made-up specimen at T₀ and that measured on the naked specimen.

30 New photos are then taken at various times, namely: T 1 hour; T 3 hours; T 5 hours; T 6 hours; T 7 hours; and T 24 hours.

b) Measurement of the curl

The measurements are performed on the photos taken as indicated above.

The curling is characterized by a median angle "a" created or formed between the base of the specimen and the line of the average height of the fringe.

5 As illustrated in Figure 2, a first point is noted at the intersection of the axes of the target and a second point is also noted facing the average width of the tuft of eyelashes.

A line is drawn between these two points and the angle thus formed between this line and the base of the target is measured. Thus, the curl value is given on the horizontal axis.

10 These measurements are taken manually with a protractor, as also illustrated in Figure 2.

By convention, the average fringe height above the horizontal axis is taken.

15

B. Protocol for measuring the play time

For each of the formulations used in the examples described below, the false eyelashes of the specimens are made up using the same application action until the appearance of grains on the specimens is obtained.

20 The number of applications performed until the first grains appear gives a measurement of the play time of the test composition.

Each of the tests is performed three times.

The scale used for this measurement is as follows:

25 Value 1: very good play time, 30 to 40 applications without grains;

Value 2: acceptable play time, 15 to 30 applications without grains;

Value 3: mediocre play time, 10 to 15 applications without grains;

Value 4: poor play time, 5 to 10 applications without grains;

Value 5: very poor play time, appearance of grains from the first applications.

30

EXAMPLES

EXAMPLE 1: Compositions according to the invention

A mascara composition according to the invention was prepared as indicated below.

1/ Preparation protocol

5 All the starting materials, with the exception of the preserving agents and the carnauba wax microbeads, are first placed in a tank.

The mixture thus obtained is heated up to a temperature of 90°C. At about 70°C, turbomixers and paddles are switched on to stir the mixture.

10 The mixture is dispersed for 20 minutes at a temperature of 90°C and then cooled with stirring (turbomixers and paddles).

The carnauba wax microbeads are introduced into the mixture at a temperature of about 35-40°C with paddle stirring.

Cooling is continued to room temperature.

15 The preserving agents are then introduced while homogenizing solely with paddles, and the tank is then emptied.

2/ Mascara composition according to the invention

Cosmetic type	Chemical name	Mascara 1 (Weight%)
Filler	Distearyldimethylammonium-modified hectorite (Bentone 38 VCG - Elementis)	6
Dye	Black iron oxide (CI: 77499) (Sunpuro Black Iron Oxide C33-7001 - SUN)	6
Fatty substances	White beeswax (GR B 889 - Koster Keunen)	8.7
	Isohexadecane	15
	Carnauba wax microbeads (Microcare 350 - Micro Powders)	7
	Refined sunflower oil (Sunflower wax - Koster Keunen)	2.3
Vinyl polymer	Vinyl acetate/allyl stearate copolymer (65/35) (Mexomer PQ - Chimex)	3

Polymer	Polybutene (monoolefins/isoparaffins)(MW: 920) (Indopol H 100 - from Ineos)	10
	Hydrogenated C36 diacid/ethylenediamine condensate, esterified with stearyl alcohol (MW: about 4000), stabilized (Anox 20) (Oleocraft LP-10-PA-(MV) - Croda)	1
SCP polymer	Polybehenyl acrylate (Intelimer IPA 13-6 - Air Products & Chemicals)	3
Silicone	Cyclohexadimethylsiloxane (viscosity: 8 cSt) (KF-996 - Shin-Etsu)	10
	Dimethiconol-grafted silicate resin (low tack) in isododecane (40% BioPSA active agent) (Dow Corning 7-4405 Cosmetic Fluid - Dow Corning)	5
Preserving agent		3
Solvent	Propylene carbonate (Arconate propylene carbonate - Lyondell)	2
	Isododecane	18

3/ Results

The protocols described previously were applied to this mascara composition in order especially to study the curling and play time properties thereof.

5 The results obtained were compared with the results obtained:

- in the absence of application of makeup (negative control);

- with the commercial composition Maybelline Volume Express WP® (comparative 1), and

10 - with the commercial composition Maybelline Volume Express WP® combined with the application of an Agnès b heating brush (Chauffant Curl Brushing® comb) (comparative 2).

These results are presented together in Figure 3.

15 First, the curl values measured in the absence of makeup reflect the natural curl of the eyelashes. The values thus obtained remain very low.

The composition in accordance with the invention gives significantly better eyelash curling than that obtained with the two comparative tests.

Thus, the curl angle value obtained with mascara 1 according to the invention is 2.5 times greater than that obtained with comparative 2 and more than 4 times greater
5 than that obtained with comparative 1.

The impairment over time of this curl is proportionately similar to that observed with the comparative compositions.

In addition, a play time value of less than 4 was obtained with the mascara in accordance with the invention.

CLAIMS

1. Assembly for packaging and applying a composition for making up and/or caring for keratin fibres, especially the eyelashes or the eyebrows, comprising:

- 5 i) an anhydrous makeup and/or care composition comprising at least one sunflower wax and a volatile hydrocarbon-based oil,
ii) an element for applying said composition, and
iii) heating means for bringing said composition to a temperature suitable for its deformability.

2. Assembly according to Claim 1, in which said composition comprises as
10 volatile hydrocarbon-based oil at least isododecane, and preferably isododecane and isohehexadecane.

3. Assembly according to Claim 1 or 2, in which said composition comprises from 10% to 60% by weight and in particular from 15% to 40% by weight of volatile hydrocarbon-based oil(s) relative to the total weight of the composition.

15 4. Assembly according to any one of the preceding claims, in which said composition comprises from 0.1% to 10% by weight and in particular from 1% to 5% by weight of sunflower wax relative to the total weight of the composition.

5. Assembly according to any one of the preceding claims, in which said composition also comprises at least one volatile silicone oil, chosen especially from linear
20 or cyclic silicone oils, in particular linear or cyclic polydimethylsiloxanes (PDMS) containing from 3 to 7 silicon atoms.

6. Assembly according to any one of the preceding claims, in which said composition also comprises at least one microwax, especially a carnauba microwax.

7. Assembly according to the preceding claim, in which the heating
25 temperature of the heating means is less than or equal to 5°C relative to the melting point of the microwax, preferably strictly less than 5°C relative to the melting point of the microwax.

8. Assembly according to any one of the preceding claims, in which the
30 composition comprises at least one polymer chosen from the group formed from semi-crystalline polymers; liposoluble film-forming polymers; and polymers (A) derived from the (co)polymerization of at least one at least C₄ alkene monomer, and preferably

comprises at least one semi-crystalline polymer, at least one liposoluble film-forming polymer and at least one polymer (A) derived from the (co)polymerization of at least one at least C₄ alkene monomer.

9. Assembly according to the preceding claim, in which the liposoluble film-
5 forming polymer is a vinyl ester copolymer.

10. Assembly according to Claim 8 or 9, in which the semi-crystalline polymer is chosen from poly(C₁₀-C₃₀)alkyl acrylates.

11. Assembly according to any one of Claims 8 to 10, in which polymer (A) has a weight-average molecular mass of greater than or equal to 750 g/mol, advantageously
10 between 800 and 10 000 g/mol, more preferentially between 900 and 5000 g/mol and is preferably a poly-1-butene homopolymer.

12. Assembly according to any one of the preceding claims, in which said composition also comprises at least one non-volatile oil.

13. Assembly according to any one of the preceding claims, in which the
15 composition comprises at least one dyestuff, preferably chosen from pulverulent materials, liposoluble dyes and water-soluble dyes, and mixtures thereof.

14. Assembly according to any one of the preceding claims, in which the composition is a mascara.

15. Assembly according to any one of the preceding claims, in which the
20 heating means are capable of bringing the composition to a temperature of greater than or equal to 30°C, preferably greater than or equal to 45°C, in particular to a temperature of between 50°C and 75°C and better still between 60°C and 65°C.

16. Assembly according to any one of the preceding claims, in which the heating means are combined with the application element.

25 17. Assembly according to any one of the preceding claims, in which the heating means are for bringing the composition, prior to, simultaneously with or after its application, to a temperature suitable for its deformability.

18. Anhydrous mascara composition comprising at least one sunflower wax and a volatile hydrocarbon-based oil.

30 19. Composition according to the preceding claim, being as defined according to any one of Claims 2 to 14.

20. Non-therapeutic cosmetic process for making up and/or caring for keratin fibres, especially the eyelashes or the eyebrows, comprising the application to said keratin fibres of a cosmetic composition as defined in any one of Claims 1 to 14, said composition being heated to a temperature of greater than or equal to 30°C, preferably greater than or equal to 45°C, in particular to a temperature of between 50°C and 75°C and better still between 60°C and 65°C.

21. Process according to the preceding claim, in which said composition is heated before application to the keratin fibres.

22. Cosmetic use of a composition as defined according to any one of Claims 1 to 14, for obtaining a film deposited on keratin fibres, especially the eyelashes or the eyebrows, which is uniform and which has improved curling properties and/or improved persistence of this curling over time.

23. Cosmetic use of a composition as defined according to any one of Claims 1 to 14, to obtain a mascara that has good play time properties.

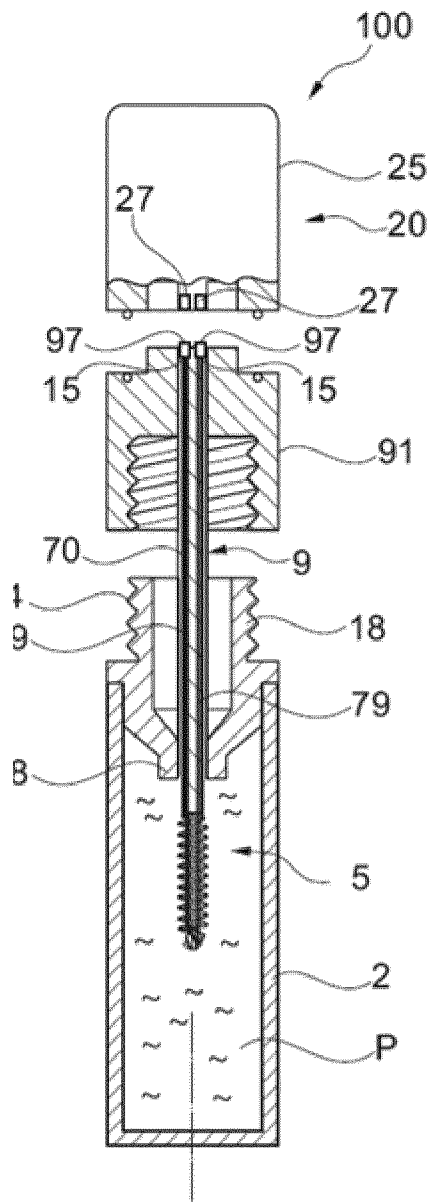

Figure 1a

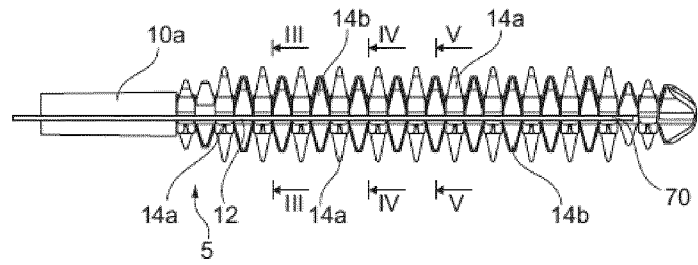

Figure 1b

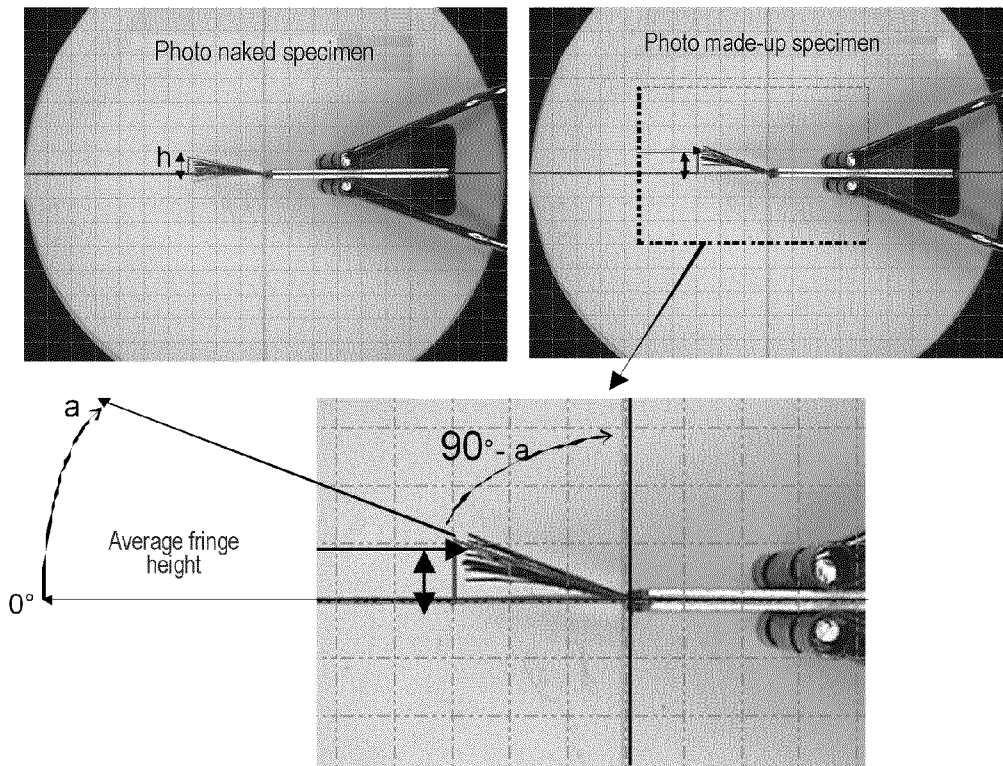

Figure 2

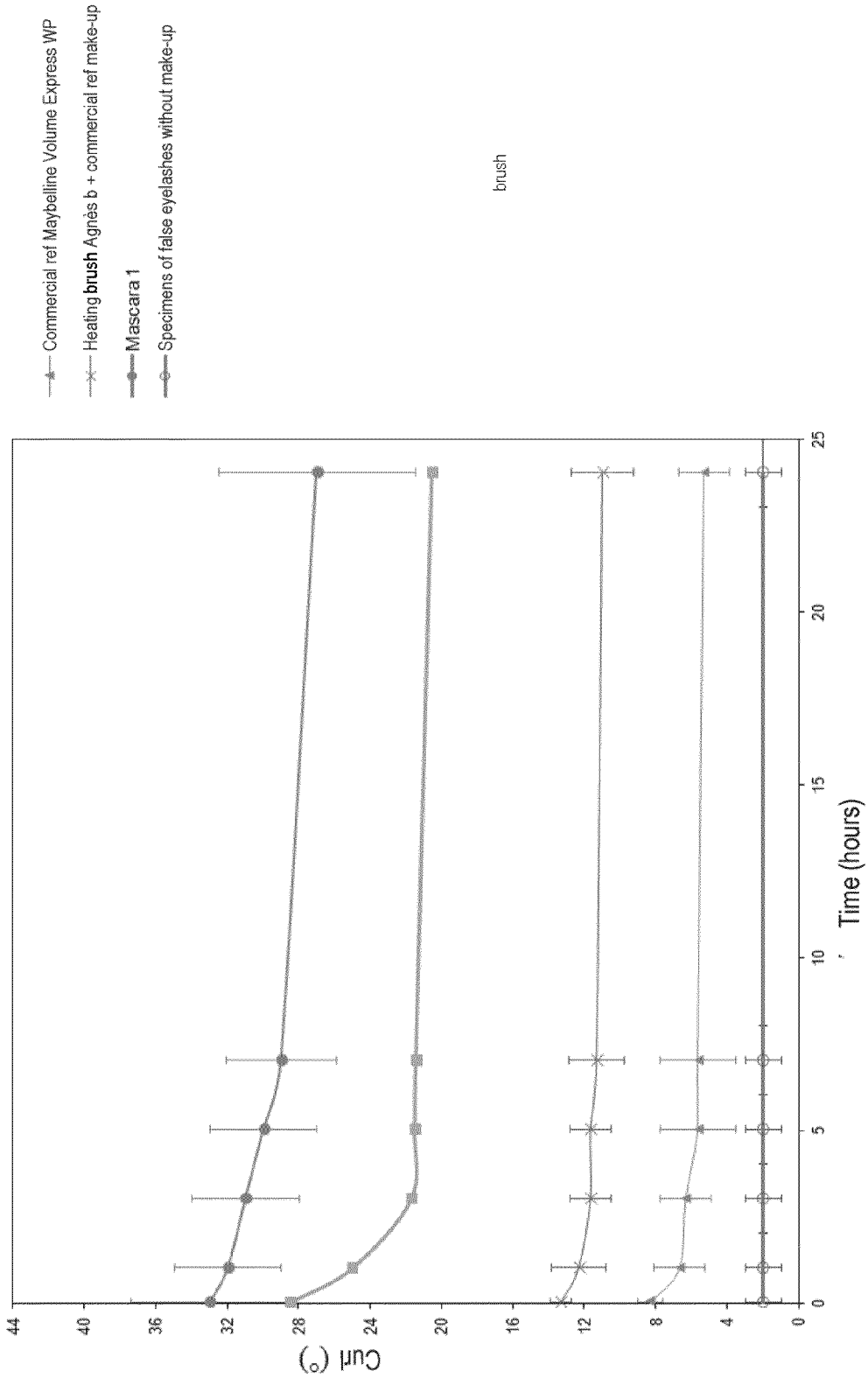

Figure 3

INTERNATIONAL SEARCH REPORT

International application No
PCT/EP2016/050218

A. CLASSIFICATION OF SUBJECT MATTER
 INV. A61K8/31 A61Q1/10 A61K8/92 A61K8/04
 ADD.
 According to International Patent Classification (IPC) or to both national classification and IPC

B. FIELDS SEARCHED
 Minimum documentation searched (classification system followed by classification symbols)
 A61K A61Q
 Documentation searched other than minimum documentation to the extent that such documents are included in the fields searched

Electronic data base consulted during the international search (name of data base and, where practicable, search terms used)
 EPO-Internal, WPI Data

C. DOCUMENTS CONSIDERED TO BE RELEVANT		
Category*	Citation of document, with indication, where appropriate, of the relevant passages	Relevant to claim No.
X	EP 2 133 067 A1 (BEIERSDORF AG [DE]) 16 December 2009 (2009-12-16) paragraphs [0011] - [0014], [0022] - [0028], [0042], [0048], [0054] - [0055], [0058]; claims -----	1-23
X	EP 2 181 700 A1 (BEIESRDORF AG [DE]) 5 May 2010 (2010-05-05) page 6 - page 7; example 9 -----	1-23
X	FR 2 936 418 A1 (OREAL [FR]) 2 April 2010 (2010-04-02) page 2, line 4 - page 3, line 36 page 6, line 5 - page 7, line 25 page 28, lines 3-37 example 2 -----	1-23

Further documents are listed in the continuation of Box C.

See patent family annex.

* Special categories of cited documents :

- "A" document defining the general state of the art which is not considered to be of particular relevance
- "E" earlier application or patent but published on or after the international filing date
- "L" document which may throw doubts on priority claim(s) or which is cited to establish the publication date of another citation or other special reason (as specified)
- "O" document referring to an oral disclosure, use, exhibition or other means
- "P" document published prior to the international filing date but later than the priority date claimed

- "T" later document published after the international filing date or priority date and not in conflict with the application but cited to understand the principle or theory underlying the invention
- "X" document of particular relevance; the claimed invention cannot be considered novel or cannot be considered to involve an inventive step when the document is taken alone
- "Y" document of particular relevance; the claimed invention cannot be considered to involve an inventive step when the document is combined with one or more other such documents, such combination being obvious to a person skilled in the art
- "&" document member of the same patent family

Date of the actual completion of the international search

14 March 2016

Date of mailing of the international search report

23/03/2016

Name and mailing address of the ISA/

European Patent Office, P.B. 5818 Patentlaan 2
 NL - 2280 HV Rijswijk
 Tel. (+31-70) 340-2040,
 Fax: (+31-70) 340-3016

Authorized officer

Paul Soto, Raquel

INTERNATIONAL SEARCH REPORT

Information on patent family members

International application No

PCT/EP2016/050218

Patent document cited in search report	Publication date	Patent family member(s)	Publication date	
EP 2133067	A1	16-12-2009	DE 102008001776 A1	19-11-2009
			EP 2133067 A1	16-12-2009

EP 2181700	A1	05-05-2010	DE 102008056373 A1	06-05-2010
			EP 2181700 A1	05-05-2010

FR 2936418	A1	02-04-2010	NONE	
