

[54] **PERSONAL SECURITY DEVICE**

[75] Inventors: **John C. Bogue**, 101 Ocean Ave.;
Robert I. Sarbacher, both of Santa
Monica, Calif.

[73] Assignee: **said Bogue, by said Sarbacher**

[22] Filed: **May 18, 1972**

[21] Appl. No.: **254,409**

[52] U.S. Cl. **325/119, 325/111, 325/118,**
325/185, 136/90, 340/224

[51] Int. Cl. **H04b 1/02**

[58] Field of Search **D26/1, 5; 136/90, 90.3,**
136/90.4, 112, 113, 182; 325/66, 105, 111,
113, 114, 115, 116, 118, 119, 185, 186, 102,
310, 352, 361; 340/224, 258 R, 276, 283;
343/225, 226; D56/4 B

[56]

References Cited

UNITED STATES PATENTS

3,005,909	10/1961	Grandoff, Jr.	136/90 X
3,032,651	5/1962	Gisiger-Stähli et al.	325/310 X
3,179,891	4/1965	Sharma	325/310 X

3,481,791	12/1969	Orsino	136/90 X
3,493,955	2/1970	Minasy	340/258 R

OTHER PUBLICATIONS

Popular Science Monthly; May 1947, page 101

Primary Examiner—Benedict V. Safourek
Attorney, Agent, or Firm—Witherspoon and Lane

[57]

ABSTRACT

A self-powered electromagnetic signaling device having the appearance of a lipstick, ring, cigarette lighter, hotel or motel key or any other device commonly worn on the person or carried is disclosed. The device utilizes a reserve battery that remains inactive until actuated. Since the battery remains inactive unless actuated, the power source for the signaling device has a long stand-by life. The battery is actuated by a pushing, turning or pressing motion that can be accomplished without attracting attention. Once the battery is activated, the device emits a continuous signal until the energy of the battery has been exhausted.

10 Claims, 21 Drawing Figures

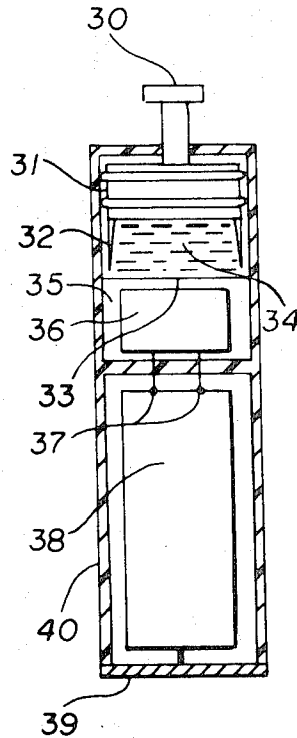

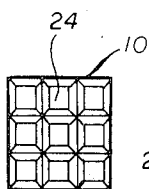

FIG. 2

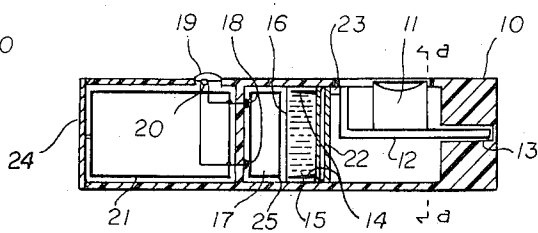
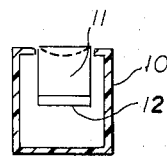

FIG. 1



section a-a
FIG. 3

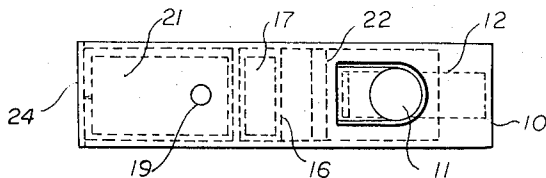

FIG. 4

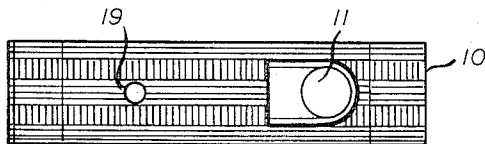

FIG. 5

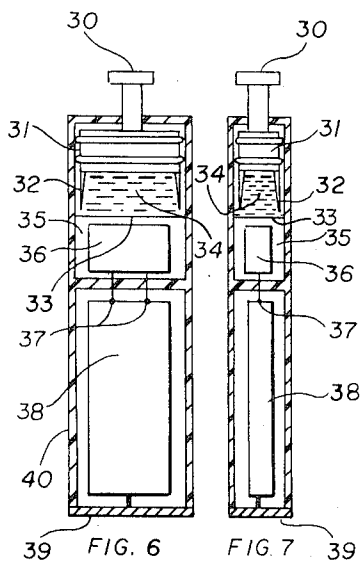

FIG. 6

FIG. 7

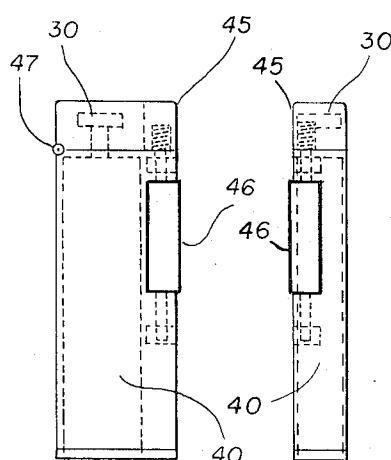

FIG. 8

FIG. 10

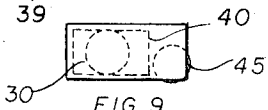

FIG. 9

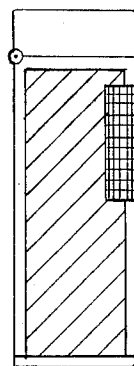

FIG. 11

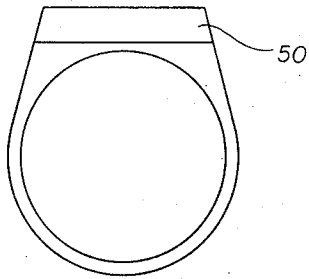

FIG. 12

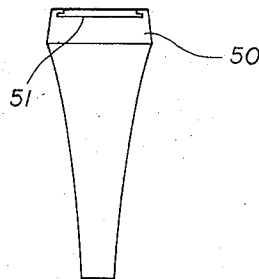

FIG. 13

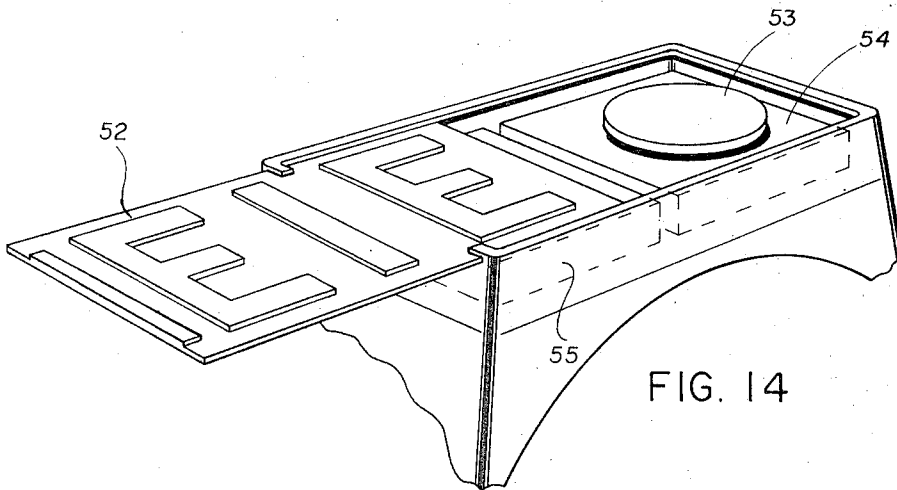

FIG. 14

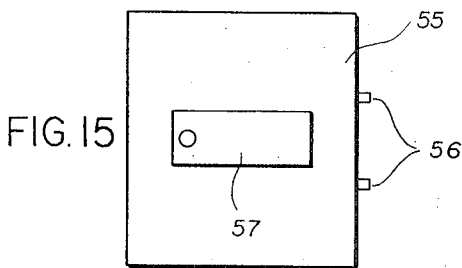

FIG. 15

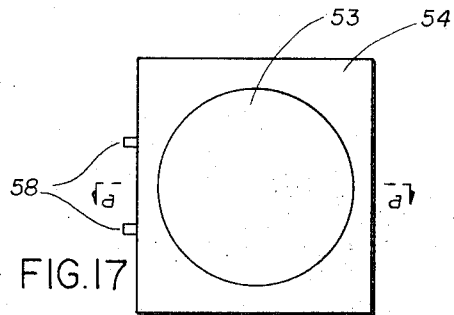

FIG. 17

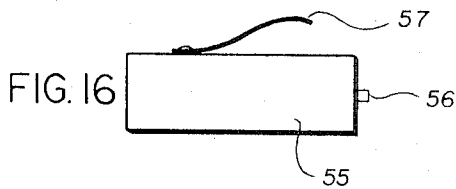

FIG. 16

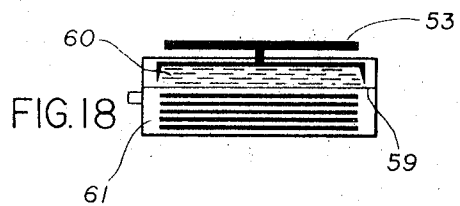
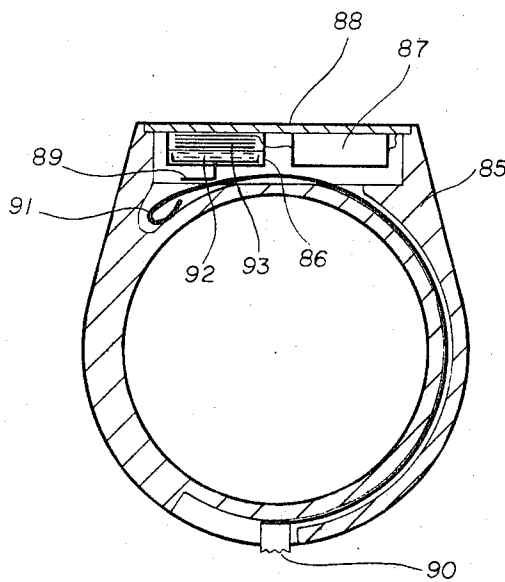
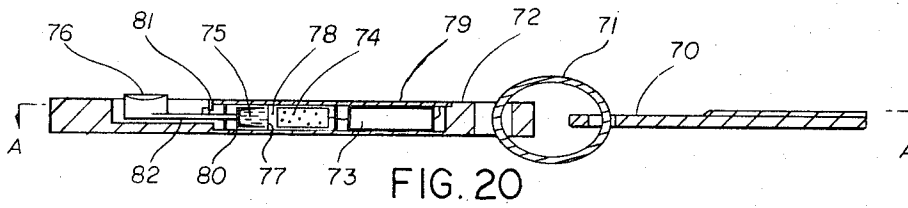
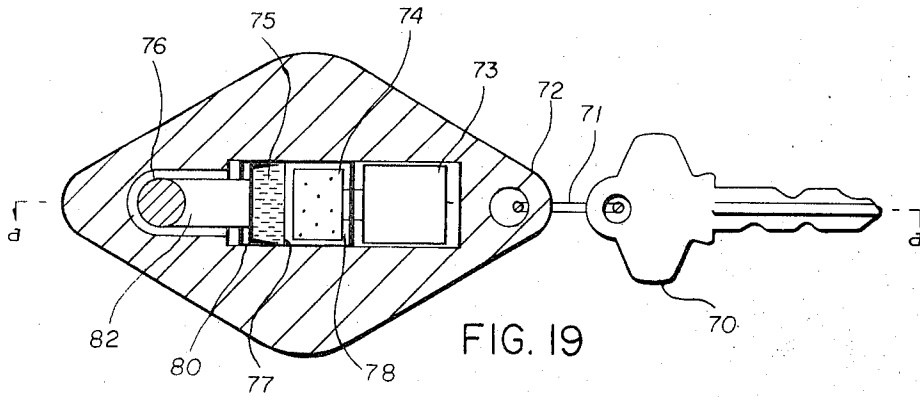

FIG. 18



PERSONAL SECURITY DEVICE

BACKGROUND OF THE INVENTION

This invention relates to electromagnetic signaling devices, and, more specifically, to self-powered electromagnetic distress signaling devices having the appearance of objects commonly worn on the person or carried by a person.

There are a number of instances where a very small signaling device can be used, particularly in the personal security area. Unfortunately, it appears that the number of persons being attacked is continuously increasing. Hardly a day passes that we do not hear or read of an attack. Furthermore, these attacks occur in almost any place. For example, people have been attacked in public parks, in public buildings, in elevators, in their automobiles, in rest rooms and in motel and hotel corridors. Today no place, particularly a place where only one or two persons may be present at any given time, appears to be safe. If the person being attacked had some means of summoning help, the attack could possibly be thwarted or the attacker might be apprehended.

There are, of course, many different types of personal signaling devices available on the market today. Unfortunately, most of these signaling devices are relatively bulky, cannot be readily turned-on, cannot usually be operated without alerting the assailant and are usually so designed that the assailant is fully aware of the fact that the device is a signaling device. Since the device is readily recognizable, the assailant can take the device away from his victim even before it is turned-on or if turned-on, the assailant need merely turn it off or destroy the device. In addition, most if not all of the presently available personal signaling devices use dry cells as an electrical power source. If the device is not periodically checked for proper operation or if the dry cells are not periodically replaced, the device may be inoperative at the time it is needed because the batteries are dead or have so deteriorated as to be useless. This invention provides an electromagnetic signaling device that has an extremely long stand-by life, is readily actuated without attracting notice and is so fabricated that it does not have the appearance of a signaling device.

SUMMARY OF THE INVENTION

This invention provides a self-powered electromagnetic signaling device that is camouflaged so as to have the appearance of an object normally worn or carried by a person. More particularly, such electromagnetic signaling devices having the appearance of a lipstick, a cigarette lighter, a motel or hotel key, and a ring are specifically disclosed.

The signaling device comprises a transmitter and a deferred action battery. The battery which provides power to the transmitter remains inactive until it is actuated. Therefore, the transmitter remains in a quiescent state until the battery is actuated. The actuating means provided with a particular signaling device is so designed that it appears to be a part of the lipstick, ring, etc. That is, it is not so distinctive that its purpose is readily apparent. In addition, the actuating mechanism is so structured that it can be readily operated without attracting attention.

As soon as the battery is actuated, the transmitter emits a distress signal. A receiver located at a source of help will pick up this signal and dispatch assistance. This signal can be transmitted directly to the source of help; however, due to its size and power output, the signaling device of this invention would normally be associated with a nearby transponder. The transponder would pick up the distress signal and retransmit the signal at an increased power level to the source of help. The output of the transponder can be transmitted to the source of help by land line or by radio. In addition, the transponder system could include coded information to denote the general area in which the distress signal emanates. Such systems are well known in the art and do not form a part of this invention.

Due to the fact that the battery remains inactive until actuated, the signaling device has essentially unlimited stand-by life. The battery will not become dead merely because of age. Thus, in effect the battery is a fresh power supply when needed no matter how long the signaling device has been in a stand-by state. One need not replace the battery periodically as is the case with the batteries conventionally used in such devices. The battery or the entire device, depending upon how the signaling device is constructed, will of course have to be replaced after the battery is actuated because the device continues to operate until the power supply is exhausted. In addition to the practically unlimited stand-by life, the signaling device of this invention is so fabricated that an assailant would normally be unaware of the fact that his intended victim is signaling for help. Even if the device is in view of the assailant, he would normally be unaware of its existence due to the fact that it looks like an object normally worn or carried. Furthermore, the device can be actuated in all its forms without any readily perceptible movement on the part of the user.

DESCRIPTION OF THE DRAWINGS

A complete understanding of the invention can be obtained from the following detailed description of the invention when read in conjunction with the annexed drawings in which:

FIG. 1 shows a cross sectional view of the signaling device of this invention as it is incorporated into a lipstick container;

FIG. 2 is an end view of the lipstick container of FIG. 1;

FIG. 3 is a section view of FIG. 1 taken along the line *a-a*;

FIG. 4 is a top view of the lipstick container of FIG. 1;

FIG. 5 is another top view of the lipstick container showing stylations such as may be molded into the case to beautify the external appearance;

FIG. 6 is a cross sectional view showing the signaling device of this invention fabricated as an insert for a cigarette lighter case;

FIG. 7 is a side view in cross section of the insert of FIG. 6;

FIG. 8 shows a front view of a cigarette lighter case with the insert of FIG. 6 inside the case;

FIG. 9 is a top view of FIG. 8;

FIG. 10 is a side view of FIG. 8;

FIG. 11 shows what may typically be the outside appearance of the cigarette lighter case;

FIG. 12 shows a side view of a ring that contains the signaling device of this invention;

FIG. 13 shows an end view of the ring of FIG. 12;

FIG. 14 shows a perspective view of the ring of FIG. 12 with the top open, exposing the actuating button of the signaling device;

FIG. 15 shows a view of the transmitter contained in the ring of FIG. 12;

FIG. 16 shows another view of the transmitter of FIG. 15;

FIG. 17 shows a plan view of the battery contained in the ring of FIG. 12;

FIG. 18 is a cross sectional view of the battery taken along the line *a-a* of FIG. 17;

FIG. 19 shows a motel or hotel key with a cross sectional view of the attached identification tag and signal device carried in the tag;

FIG. 20 is a cross sectional view taken along the line *a-a* of FIG. 19; and

FIG. 21 shows a second ring mounted embodiment of the invention.

DESCRIPTION OF THE INVENTION

Referring to FIGS. 1 - 5, a plastic lipstick case 10 is shown containing the signaling system of this invention. As shown, lipstick case 10 contains a transmitter 21, a battery comprising an electrode compartment 25, electrodes 17, the electrolyte 15 and a diaphragm 16 which constrains electrolyte 15 from entering compartment 25. As long as electrolyte 15 is kept out of electrode compartment 25, the battery is inactive and no voltage is present across the battery terminals 18. As shown in FIG. 1, battery terminals 18 are electrically connected to transmitter 21 and to a gallium arsenite phosphite crystal 20. A window or lens 19 is provided in lipstick case 10 directly above crystal 20. The output of transmitter 21 is connected to an antenna 24. Antenna 24 is integrally fabricated into one end of lipstick case 10 as clearly shown in FIG. 2.

In addition to the battery and transmitter, a battery actuating mechanism is also contained in lipstick case 10. This actuating mechanism comprises an operating button 11, a spring arm 12, a baffle 22, a stop 23 and the arms 14. Stop 23 prevents accidental movement of spring arm 12. The free end of spring arm 12 is housed in a channel 13 cut into one end of lipstick case 10 as shown in FIG. 1.

FIG. 3 which is a section view taken along the line *a-a* of FIG. 1 and FIG. 1 shows that actuating button 11 is essentially flush with the surface of case 10 and in the position shown in FIGS. 1 and 3-5 before the battery is actuated. Spring arm 12 holds button 11 in this position; however, button 11 is free to move downward past stop 23 under pressure into case 10 as shown in FIGS. 1 and 3.

FIG. 5 shows the overall appearance that may be imparted to lipstick case 10. As can be seen from the drawing, case 10 looks like a typical lipstick container. Of course any design typical of a lipstick case can be imparted to case 10.

Lipstick case 10 is carried by a woman just as she would carry her normal lipstick. The device remains in its quiescent state until needed. If she should be attacked or in danger, she would merely push button 11 down and forward (toward baffle 22). This motion causes spring arm 12 to push movable baffle 22 forward toward diaphragm 16. This movement of baffle 22

causes arms 14 to puncture diaphragm 16. When diaphragm 16 is broken, electrolyte 15 is admitted to the electrode compartment 25, thereby activating the battery. Holding case 10 so that antenna 24 is pointing downward will, of course, facilitate the flowing of electrolyte 15 into compartment 25. As soon as the battery is activated, transmitter 21 turns on and crystal 20 is energized, thereby providing a light that is visible through window 19. The output of transmitter 21 is radiated by antenna 24. The provision of crystal 20 and window 19 is optional and is not a necessary part of the signaling device.

The signal radiated by antenna 24 is received at, for example, a police station or other location where a source of help is available. This signal can be received directly at the source of help; however, due to the fact that the output power of transmitter 21 is limited, transmitter 21 will normally be associated with a transponder system. The transponder which would be located in the vicinity responds to the signal from transmitter 21 and sends a signal by radio or land line to the source of help. The transponder output could and normally would be coded to give the general location of the distress signal.

FIGS. 6 and 7 show the signaling device fabricated as an insert for a cigarette lighter case and FIGS. 8-10 show the device contained in a typical cigarette lighter case. FIG. 11 shows what may be the typical appearance of the device when contained in a cigarette lighter case. The appearance is that of a typical cigarette lighter. Of course the lighter may be fabricated to have any desired physical appearance. The cigarette lighter case shown is of the type manufactured by the Dunhill Manufacturing Company and comprises the plastic case 45 having a wheel 46 and a hinged cap 47. Rotation of wheel 46 opens cap 47.

Referring to FIGS. 6 and 7, these figures show an insert 40 sized to fit inside lighter case 45. Insert 40 contains a transmitter 38, a battery comprising the electrodes 36, the electrode compartment 35, the electrolyte 34, a diaphragm 33 that prevents the electrolyte from entering electrode compartment 35 and a battery actuating mechanism comprising the actuating button 30, the piston 31 and the sharp projections 32. The battery is connected to transmitter 38 at the terminals 37 and the output of transmitter 38 is connected to the antenna 39 which forms the bottom part of insert 40. When this assembly is completed it is inserted into case 45 so that antenna 39 forms the bottom of the case.

When the entire assembly is completed it looks exactly like a cigarette lighter as is apparent from FIG. 11. The signaling device remains in a stand-by condition until needed. When needed, the user merely turns wheel 46 to open lid 47 and then pushes down on button 30. Depressing button 30 causes piston 31 to move downward which in turn causes projections 32 to move downward and puncture diaphragm 33. When diaphragm 33 is punctured, electrolyte 34 flows into electrode compartment 35, thereby activating the battery. As soon as the battery is activated, transmitter 38 is turned-on and a signal emanates from antenna 39. This signal, as was the case with the lipstick embodiment, is received at a source of help either directly or through a transponder system.

FIGS. 12-14 show a signet ring which is designed to contain the signaling system of this invention. The ring has the appearance of an ordinary signet ring as is ap-

parent from these figures, but is so constructed that the top 50 of the ring contains a hollow area for housing the components of the signaling system. A sliding panel 51 covers the top of the ring to conceal the components and in addition this panel which is made of metal serves as the antenna of the system. Panel 51 will have a design such as the letters 52 shown in FIG. 14. These letters may spell the name of the wearer or may be the wearer's initials or the initials or name of an organization as is customary. Of course, panel 51 may carry any other suitable design.

FIG. 15 shows the manner in which the components of the signaling system are housed in the top 50 of the ring and FIGS. 15-18 show these components in detail. As shown in these Figures, the signaling system comprises a transmitter 55, the reserve battery 54 and a spring contact 57. Spring contact 57 is provided to couple the output of transmitter 55 to antenna 51. Transmitter 40 is provided with a pair of power input terminals 56.

Battery 54 shown in detail in FIGS. 17 and 18 comprises an electrode compartment 61, the electrolyte 60, a diaphragm 59 which isolates electrolyte 60 from electrode compartment 61, a pair of terminals 58 and an actuating mechanism 53. As can be clearly seen in FIG. 18, which is a section view taken along the lines *a-a* of FIG. 17, the pressing down of the button of actuating mechanism 53 will rupture diaphragm 59, thereby permitting electrolyte 60 to flow into electrode compartment 61. As soon as electrolyte 60 flows into compartment 61, battery 54 will be activated. When these components are placed in top 50 of the ring, battery terminals 58 are connected to transmitter power terminals 56 so that activation of the battery will energize the transmitter. Of course, battery 54 is not activated until the signaling system is needed.

When the battery 54 and transmitter are placed in top 50 of the ring and properly interconnected, panel or antenna 51 is closed and the ring is placed on the wearer's finger. The ring looks like any ring that a person might wear. If an emergency arises and the wearer desires to summon for help, he merely pushes down on the button of actuating mechanism 53 to signal for help. Again, the signal emanating from antenna 51 may be received directly at a source of help or through a transponder. The tolerances of the top of the ring 50, the panel 51 and actuating mechanism may be such that one needs merely to push down on panel 51 to activate battery 54. Of course, panel 51 can be opened slightly to permit the wearer to directly push down on the actuating button. The panel could be moved back in place immediately after actuation. This motion could easily be accomplished without attracting attention.

FIG. 21 shows another embodiment of the ring housed signaling system. In this embodiment the panel 88 of ring 85 serves as the antenna for the transmitter 87. The battery 86 is again a reserve battery in which the electrolyte 92 is kept separated from the electrodes 93 until battery 86 is to be activated.

The basic difference between this embodiment and the embodiment shown in FIGS. 12-18 is the manner in which the battery is activated. As shown in FIG. 21, this activating mechanism comprises a metal strap 91 and an arm 89 which has a pair of sharp projections secured to the end opposite the end adjacent strip 91. Strap 91 is enlarged at one end and has an operating button 90 secured to its other end. A portion of the

band of ring 85 is hollowed out to accommodate strap 91 and in addition a channel is cut into the band in the area of button 90 to permit movement of the button.

When the wearer of ring 85 desires to summon for help, he slides button 90 along the channel cut into the band (right to left in FIG. 21). This causes the enlarged part of strap 91 to push arm 89 toward electrodes 93, thereby puncturing the seal that separates electrolyte 92 from electrodes 93. When this seal is ruptured, electrolyte 92 flows into the electrode compartment, thereby activating the battery 86. When battery 86 is energized, transmitter 87 is energized and a distress signal emanates from antenna 88.

FIGS. 19 and 20 show the signaling system contained in the identification tag of a motel or hotel key. FIG. 20 is a section view taken along the line *a-a* of FIG. 19. As shown in these Figures, the key 70 is attached to a tag 72 by means of a chain link 71. Most, if not all, motel and hotel keys are attached to a tag such as tag 72. Such tags generally are made of plastic and carry the name of the motel or hotel and the room number for that key. Unlike the regular key tag, tag 72 houses the signaling system of this invention.

As shown in FIGS. 19 and 20, the signaling system comprises the transmitter 73 and a reserve battery comprising an electrode compartment 78, the electrolyte 75, the electrodes 74 and a diaphragm 77 which isolates electrolyte 75 from electrode compartment 78. In addition to the electrolyte, diaphragm and electrodes in the electrode compartment, the battery is also equipped with an actuating mechanism which comprises a shaft 82 having a button 76 secured to one end and a piston 80 secured to the other end. Piston 80 has a pair of sharp projections as shown in FIGS. 19 and 20. A stop 81 is provided to prevent accidental movement of button 76 toward key 70. With all the components in the position shown in FIG. 20, the battery is inactive because diaphragm 77 prevents the flow of electrolyte 75 into compartment 78.

When the apparatus is installed into tag 72, all the components are in the position shown in FIGS. 19 and 20. The battery is inactive and is, of course, connected to transmitter 73. The output of transmitter 73 is connected to an antenna 79. Antenna 79 is a metallic plate that is embedded into plastic tag 72 and in addition to serving as the antenna of the system, it covers the battery and transmitter 73. When the key tag assembly is completed, tag 72 takes on the appearance of an ordinary motel or hotel key tag. It will carry the normal printing carried on such a tag.

After installation the system remains in a stand-by condition until an emergency arises. If, for example, a guest is attacked while going to his room, he merely pushes button 76 downward and toward key 70. This motion moves piston 80 toward key 70, thereby rupturing diaphragm 77. The rupturing of diaphragm 77 permits electrolyte 75 to flow into electrode compartment 78, thereby activating the battery. When the battery is activated, transmitter 73 is energized and a signal appears on antenna 79. The signal will be picked up at the clerk's desk for example and help can be rapidly dispatched. As was the case with the other embodiments, this signal can be received directly from antenna 79 but inside a motel or hotel a transponder system would most likely be employed. This transponder system could be incorporated into any other security system the hotel or motel may have.

From the foregoing description it should be obvious that this invention provides a security device that is not readily recognizable as such. The device is easily put in operation in an emergency and can be actuated without attracting attention to the fact that the user has turned-on something. In all the embodiments, the battery can be activated with very little motion. Furthermore, the security device of this invention has for all practical purposes an infinite stand-by life. It will, therefore, be in operating condition when needed without any periodic maintenance or periodic replacement of parts. None of the parts should have to be replaced unless, of course, they are physically damaged or the system has been activated. Once the system is activated, the transmitter will continue to transmit the distress signal until the battery is exhausted. Once the transmitter is turned-on, it cannot be turned off. The only way the transmitter will be silenced is when the battery is run down or if, of course, it is smashed. After the device is activated, the entire system can be replaced or, if the fabrication techniques so permit, only the battery with its associated actuating mechanism need be replaced.

While the signaling system has been shown and described as being housed in specific items normally worn or carried by a person, it can readily be installed into other such items. Also the gallium arsinite phosphite crystal used in the lipstick embodiment can be used with any item into which the system is incorporated. Furthermore, while the invention has been shown and described with reference to the specific embodiments, it will be obvious to those skilled in the art that various changes and modifications can be made to these embodiments without departing from the spirit and scope of the invention as defined in the claims.

What is claimed is:

1. A normally inactive security signaling system comprising: a lipstick case; a transmitter housed inside said lipstick case; a reserve battery having electrodes housed inside said lipstick case, said electrodes being electrically connected to said transmitter but housed in a separate compartment fabricated inside said lipstick case, said compartment providing physical isolation between said transmitter and said electrodes, said battery also having a liquid electrolyte stored inside said lipstick case but separated from said electrodes by means of a rupturable seal; an antenna integrally fabricated into one end of said lipstick case, said antenna being connected to said transmitter; a slot cut into one surface of said lipstick case; and battery activating means including a button located in said slot in such a manner that said button protrudes only slightly above the surface of said lipstick case, a spring arm housed inside said lipstick case and secured to said button, a piston located inside said lipstick case, said piston having sharp projections extending toward said rupturable seal, and a movable baffle located inside said lipstick case between said spring arm and said piston, said battery being activated by pushing said button downward and toward said baffle to cause said baffle to push against said piston to rupture said rupturable seal by means of said sharp projections to thereby allow said electrolyte to flow into said compartment housing said electrodes to activate said battery and thereby activate said transmitter.

2. A normally inactive security signaling system comprising: a cigarette lighter case having a hinged lid por-

tion secured to a body portion; a transmitter housed inside said cigarette lighter case; a reserve battery having electrodes housed inside said cigarette lighter case, said electrodes being electrically connected to said transmitter but housed in a separate compartment fabricated inside said cigarette lighter case, said compartment providing physical isolation between said transmitter and said electrodes, said battery also having a liquid electrolyte stored inside said cigarette lighter case but separated from said electrodes by means of a rupturable seal; an antenna integrally formed in the bottom of said cigarette lighter case; and means to activate said reserve battery including movable button housed inside said hinged lid, and a movable piston housed inside said cigarette lighter case between said rupturable seal and said button, said piston having sharp projections extending toward said rupturable seal, said battery being activated by depressing said button to move said piston toward said rupturable seal to rupture said rupturable seal by means of said sharp projections to permit said electrolyte to flow into said compartment housing said electrodes to activate said battery, thereby activating said transmitter.

3. A normally inactive security signaling system comprising: a finger ring having a compartment fabricated into the top of said ring and a slidably removable panel that covers said compartment, said panel having a conventional finger ring design thereon; a transmitter housed in said compartment and coupled to said slidably removable panel which serves as the antenna for said transmitter; a reserve battery housed in said compartment and connected to said transmitter, said battery having a battery container, electrodes housed in said container, a liquid electrolyte stored in said container but separated from said electrodes by means of a rupturable seal; and means to activate said battery by rupturing said rupturable seal, said means to rupture said rupturable seal including a piston located in said battery container said, piston having projections on one end thereof extending toward said rupturable seal and a shaft integrally fabricated on the other end thereof, said shaft extending through and beyond said battery container and a button secured to the end of said shaft extending beyond said battery case, said button being located in said compartment directly beneath said panel whereby pressing downward on said button moves said piston toward said rupturable seal to rupture said rupturable seal thereby permitting said electrolyte to flow into said electrodes to activate said battery, thereby activating said transmitter.

4. A normally inactive security signaling system comprising: a finger ring having a compartment fabricated into the top of said ring and a slidably removable panel that covers said compartment, said panel having a conventional finger ring design thereon, said finger ring also having a finger band, a part of said finger band being hollow and having a slot cut therein, said slot communicating with said hollow part of said band at one end of said hollow part with the other end of said hollow part of said finger band extending into said compartment; a transmitter housed in said compartment and coupled to said slidably removable panel which serves as the antenna for said transmitter; a reserve battery housed in said compartment and connected to said transmitter, said battery having a battery container, electrodes housed in said container and a liquid electrolyte housed in said container but separated from said

electrodes by means of a rupturable seal; and means to activate said reserve battery by rupturing said rupturable seal, said means for activating said reserve battery including a piston having projections on one end thereof, said projections extending toward said rupturable seal and a shaft fabricated on the other end of said piston, said shaft extending out of said container and toward said hollow part, said shaft having its end extending toward said finger band bent at substantially a right angle to the axis of the shaft portion extending into said container such that a part of said shaft is substantially parallel with said slidably removable panel and a metal strap having an enlarged portion on one end and a button on its other end, said strap being located in said hollow part of said finger band with the enlarged portion adjacent said portion of said shaft that is substantially parallel to said slidably removable panel, whereby movement of said button toward said hollow part of said finger band causes said enlarged portion to move said piston toward said rupturable seal to rupture said seal by means of said sharp projections to permit said electrolyte to flow into said electrodes to activate said battery thereby activating said transmitter.

5. A normally inactive security signaling system comprising: an identification tag for carrying a key, said tag having a channel therein; an antenna embedded into said tag; a transmitter housed in said channel and connected to said antenna; a reserve battery housed in said channel and electrically connected to said transmitter but physically isolated from said transmitter, said reserve battery having electrodes, an electrolyte isolated from said electrodes by means of a rupturable seal, a piston having sharp projections on one of its surfaces, said projections extending toward said rupturable seal,

and a flat metal band attached to another surface of said piston and extending in a direction away from said rupturable seal, said band having a button secured to its end opposite the end which is secured to said piston, said button extending at a right angle to the longitudinal axis of said band and being of such size that it barely extends above the surface of said tag, said rupturable seal being ruptured by pushing said button toward said piston to move said piston toward said rupturable seal to rupture said seal by means of said sharp projections to allow said electrolyte to flow into said electrodes to activate said battery thereby activating said transmitter.

6. A normally inactive security signaling system as defined in claim 1 wherein a gallium arsenite phosphite crystal is connected across said battery to give a visual indication that said battery has been activated.

7. A normally inactive security signaling system as defined in claim 2 wherein a gallium arsenite phosphite crystal is connected across said battery to give a visual indication that said battery has been activated.

8. A normally inactive security signaling system as defined in claim 3 wherein a gallium arsenite phosphite crystal is connected across said battery to give a visual indication that said battery has been activated.

9. A normally inactive security signaling system as defined in claim 4 wherein a gallium arsenite phosphite crystal is connected across said battery to give a visual indication that said battery has been activated.

10. A normally inactive security signaling system as defined in claim 5 wherein a gallium arsenite phosphite crystal is connected across said battery to give a visual indication that said battery has been activated.

* * * * *

40

45

50

55

60

65