

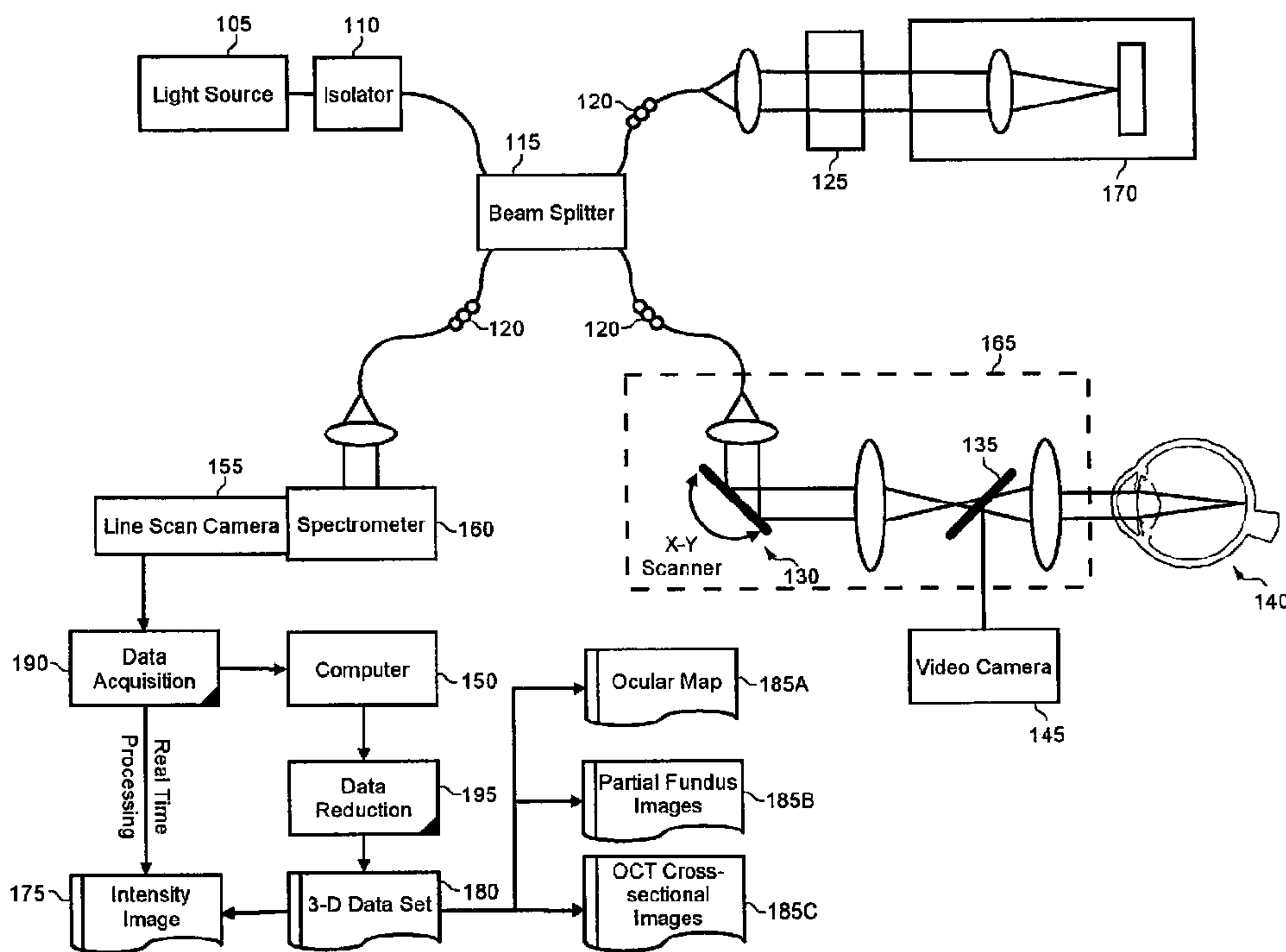

(86) Date de dépôt PCT/PCT Filing Date: 2005/12/01
 (87) Date publication PCT/PCT Publication Date: 2006/06/08
 (85) Entrée phase nationale/National Entry: 2007/04/20
 (86) N° demande PCT/PCT Application No.: EP 2005/012801
 (87) N° publication PCT/PCT Publication No.: 2006/058735
 (30) Priorités/Priorities: 2004/12/02 (US60/632,387);
 2005/09/06 (US11/219,992)

(51) Cl.Int./Int.Cl. *A61B 3/12* (2006.01),
G01B 9/02 (2006.01)
 (71) Demandeurs/Applicants:
 CARL ZEISS MEDITEC AG, DE;
 UNIVERSITY OF MIAMI, US
 (72) Inventeurs/Inventors:
 KNIGHTON, ROBERT W., US;
 JIAO, SHULIANG, US;
 GREGORI, GIOVANNI, US;
 PULIAFITO, CARMEN A., US
 (74) Agent: ROBIC

(54) Titre : TOMOGRAPHIE A COHERENCE OPTIQUE AMELIOREE POUR CARTOGRAPHIE ANATOMIQUE
 (54) Title: ENHANCED OPTICAL COHERENCE TOMOGRAPHY FOR ANATOMICAL MAPPING



(57) **Abrégé/Abstract:**

A system, method and apparatus for anatomical mapping utilizing optical coherence tomography. In the present invention, 3-dimensional fundus intensity imagery can be acquired from a scanning of light back-reflected from an eye. The scanning can include spectral domain scanning, as an example. A fundus intensity image can be acquired in real-time. The 3-dimensional data set can be reduced to generate an anatomical mapping, such as an edema mapping and a thickness mapping. Optionally, a partial fundus intensity image can be produced from the scanning of the eye to generate an en face view of the retinal structure of the eye without first requiring a full segmentation of the 3-D data set. Advantageously, the system, method and apparatus of the present invention can provide quantitative three-dimensional information about the spatial location and extent of macular edema and other pathologies. This three-dimensional information can be used to determine the need for treatment, monitor the effectiveness of treatment and identify the return of fluid that may signal the need for retreatment.

(12) INTERNATIONAL APPLICATION PUBLISHED UNDER THE PATENT COOPERATION TREATY (PCT)

(19) World Intellectual Property Organization
International Bureau(43) International Publication Date
8 June 2006 (08.06.2006)

PCT

(10) International Publication Number
WO 2006/058735 A1

(51) International Patent Classification:

A61B 3/12 (2006.01) G01B 9/02 (2006.01)

(US). PULIAFITO, Carmen, A. [US/US]; 9321 S.W. 63 Court, Pinecrest, FL 33156 (US).

(21) International Application Number:

PCT/EP2005/012801

(74) Common Representative: CARL ZEISS JENA GmbH; BECK, Bernard, Carl-Zeiss-Promenade 10, 07745 Jena (DE).

(22) International Filing Date:

1 December 2005 (01.12.2005)

(81) Designated States (unless otherwise indicated, for every kind of national protection available): AE, AG, AL, AM, AT, AU, AZ, BA, BB, BG, BR, BW, BY, BZ, CA, CH, CN, CO, CR, CU, CZ, DE, DK, DM, DZ, EC, EE, EG, ES, FI, GB, GD, GE, GH, GM, HR, HU, ID, IL, IN, IS, JP, KE, KG, KM, KN, KP, KR, KZ, LC, LK, LR, LS, LT, LU, LV, LY, MA, MD, MG, MK, MN, MW, MX, MZ, NA, NG, NI, NO, NZ, OM, PG, PH, PL, PT, RO, RU, SC, SD, SE, SG, SK, SL, SM, SY, TJ, TM, TN, TR, TT, TZ, UA, UG, US, UZ, VC, VN, YU, ZA, ZM, ZW.

(25) Filing Language:

English

(26) Publication Language:

English

(30) Priority Data:

60/632,387 2 December 2004 (02.12.2004) US
11/219,992 6 September 2005 (06.09.2005) US

(71) Applicants (for all designated States except US): CARL ZEISS MEDITEC AG [DE/DE]; Göschwitzer Str. 51-52, 07745 Jena (DE). UNIVERSITY OF MIAMI [US/US]; 1475 NW 12th Avenue, Suite 2012 (M811), Miami, FL 33136 (US).

(72) Inventors; and

(75) Inventors/Applicants (for US only): KNIGHTON, Robert, W. [US/US]; 9310 Martinique Drive, Miami, FL 33189 (US). JIAO, Shuliang [CN/US]; 13107 S.W. 90 Place, Miami, FL 33176 (US). GREGORI, Giovanni [IT/US]; 140 Santander Avenue, Coral Gables, FL 33134

(84) Designated States (unless otherwise indicated, for every kind of regional protection available): ARIPO (BW, GH, GM, KE, LS, MW, MZ, NA, SD, SL, SZ, TZ, UG, ZM, ZW), Eurasian (AM, AZ, BY, KG, KZ, MD, RU, TJ, TM), European (AT, BE, BG, CH, CY, CZ, DE, DK, EE, ES, FI, FR, GB, GR, HU, IE, IS, IT, LT, LU, LV, MC, NL, PL, PT, RO, SE, SI, SK, TR), OAPI (BF, BJ, CF, CG, CI, CM, GA, GN, GQ, GW, ML, MR, NE, SN, TD, TG).

Declaration under Rule 4.17:

— of inventorship (Rule 4.17(iv))

[Continued on next page]

(54) Title: ENHANCED OPTICAL COHERENCE TOMOGRAPHY FOR ANATOMICAL MAPPING

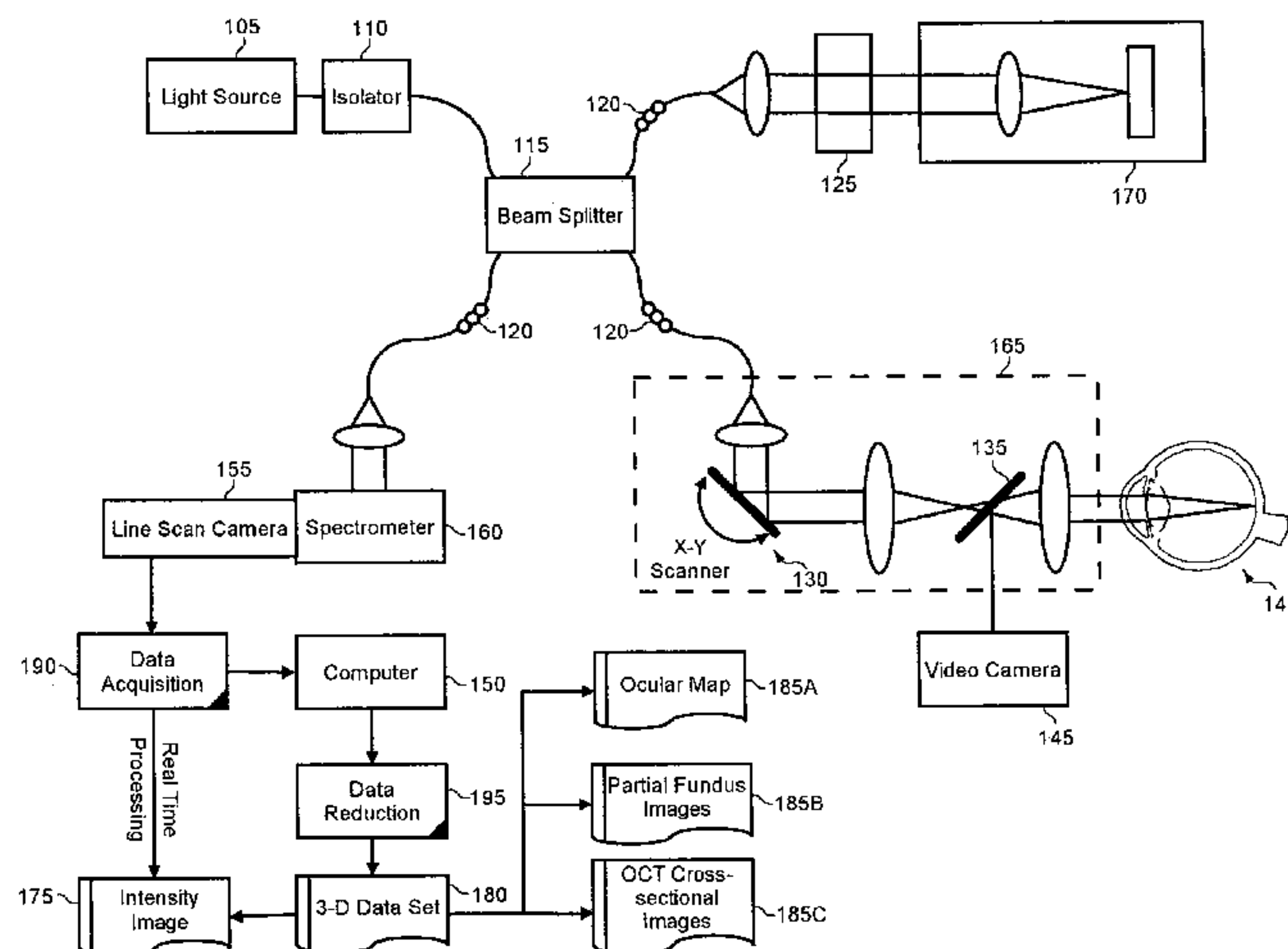

(57) Abstract: A system, method and apparatus for anatomical mapping utilizing optical coherence tomography. In the present invention, 3-dimensional fundus intensity imagery can be acquired from a scanning of light back-reflected from an eye. The scanning can include spectral domain scanning, as an example. A fundus intensity image can be acquired in real-time. The 3-dimensional data set can be reduced to generate an anatomical mapping, such as an edema mapping and a thickness mapping. Optionally, a partial fundus intensity image can be produced from the scanning of the eye to generate an en face view of the retinal structure of the eye without first requiring a full segmentation of the 3-D data set. Advantageously, the system, method and apparatus of the present invention can provide quantitative three-dimensional information about the spatial location and extent of macular edema and other pathologies. This three-dimensional information can be used to determine the need for treatment, monitor the effectiveness of treatment and identify the return of fluid that may signal the need for retreatment.

WO 2006/058735 A1

WO 2006/058735 A1



Published:

— *with international search report*

For two-letter codes and other abbreviations, refer to the "Guidance Notes on Codes and Abbreviations" appearing at the beginning of each regular issue of the PCT Gazette.

ENHANCED OPTICAL COHERENCE TOMOGRAPHY
FOR ANATOMICAL MAPPING

BACKGROUND OF THE INVENTION

Technical Field

[0001] The present invention relates to coherent waveform based imaging, and more particularly to an optical coherence tomography (OCT) imaging system.

Statement of the Related Art

[0002] Many imaging systems utilize coherent waveforms to obtain information regarding target objects of interest. Examples include OCT, ultrasound diagnostics, and synthetic aperture radar. OCT is a low-coherence interferometer-based noninvasive medical imaging modality that can provide high-resolution sectional images of biological tissues (see for example, US5321501, US5459570, Huang, D. et al. (1991). "Optical coherence tomography." *Science* **254**(5035): 1178-81). Since first introduced, OCT has been used in a variety of medical research and diagnostic applications. One successful application of OCT imagery can include the use of OCT in the dermatological imaging of the skin. Another successful application of OCT imagery can include sectional imaging of the retina in the field of ophthalmology. In this regard, time domain based OCT has produced cross-sectional images of the retina of the eye that have proven value to ophthalmologists (see for example, Swanson, E. A. et al. (1993). "In-vivo retinal imaging by optical coherence tomography." *Optics Letters* **18**(21): 1864-1866; Izatt, J. A. et al. (1993). "Ophthalmic diagnostics using optical coherence tomography". *Ophthalmic Technologies III*, SPIE, **1877**: 136-144, Los Angeles, CA, USA). Notwithstanding, time domain OCT instruments cannot acquire sufficient data to characterize completely important retinal pathologies.

[0003] The limitations of time domain OCT are the natural result of the inherent difficulties in acquiring and processing imagery of an unstable target—the human eye. For example, although ophthalmic OCT has been commercialized for several years, the spatial registration of an OCT image to fundus landmarks has not been achieved satisfactorily. In this regard, fundus landmarks can be used to relate different structural abnormalities at

ZM190PCT

different retinal locations. Precise spatial registration of OCT sections to tissue location also can be important when interpreting other medical images. Yet, the unavoidable eye movement of a patient during image acquisition can complicate the ability to achieve precise spatial registration due to the unavoidable distortion of the OCT image.

[0004] As an alternative to OCT, the scanning laser ophthalmoscope (SLO) provides en face fundus images familiar to ophthalmologists (see for example, Sharp, P. F. et al (2004) "The scanning laser ophthalmoscope—a review of its role in bioscience and medicine" Physics in Medicine and Biology 49: 1085-1096). In this regard, en face views are familiar to ophthalmologists not only from direct observations, but also from fundus photographs and fluorescein angiography. The strength of an en face view is that structural abnormalities at different retinal locations can be related to each other and to major retinal landmarks such as the fovea and optic nerve head. In any case, combining OCT with SLO (SLO/OCT) provides one possible means for precise spatial registration of the OCT image while providing an en face fundus image (see for example, US5975697, US6769769, CA2390072, US20040036838, US20040233457, and WO2004102112).

[0005] Specifically, time domain SLO/OCT systems utilize two-dimensional transverse scans to provide sectional images in planes perpendicular to the depth of the sample. In an SLO/OCT system, the fundus image can be acquired by splitting the reflected sample light during the transverse scan into two detection channels. A first channel can accommodate OCT while the second channel can be utilized in acquiring intensity image (see for example, US5975697, US6769769, CA2390072, US20040036838, US20040233457, and WO2004102112). As an alternative approach, the sectional images can be summed along the depth of the image (see for example, Hitzenberger, C. K. et al. (2003). "Three-dimensional imaging of the human retina by high-speed optical coherence tomography." Optics Express 11(21): 2753-2761; Puliafito C. A. "Summary and Significance" American Academy of Ophthalmology Subspecialty Day on retina, Section X: Ocular Imaging, New Orleans, Oct. 23, 2004, 3:06 pm). The approach of two detection channels can require a more complicated setup and the signal-to-noise ratio of the OCT may be reduced by a partial sacrifice of the back-reflected sample light. By comparison, in the approach of summing the OCT images along their depth, accuracy can be sacrificed when the eye moves between different sections.

ZM190PCT

SUMMARY OF THE INVENTION

[0006] The present invention is an OCT method, system and apparatus which addresses the foregoing deficiencies of time domain ocular imaging. In particular, what is provided is a novel method, system and apparatus for anatomical mapping using spectral domain OCT. As well, time-domain OCT and swept source frequency OCT also can be applied to provide the enhanced anatomical mapping of the present invention. In this invention, the term spectral domain OCT (SD-OCT) is sometimes used to include both spectrometer based spectral or Fourier domain OCT, and tunable laser based swept source OCT since their basic principle of operation is very similar (see for example, Choma, M. A. et al. (2003). "Sensitivity advantage of swept source and Fourier domain optical coherence tomography." Optics Express 11(18): 2183-2189). In accordance with the present invention, a fundus intensity image can be acquired from a spectral domain scanning of light back-reflected from an eye. The term "intensity image" as defined in this invention is a two-dimensional en-face image extracted from a 3D OCT data block by integrating the OCT signal over a depth range (Z-axis) greater than the axial resolution of the OCT system. For example, a fundus image can be extracted by the method disclosed herein from OCT data covering the fundus of the human eye. The fundus intensity image actually represents a reduction in total information content. Specifically, the squaring and summing over the spectra results in a loss of all depth information. Yet, the loss of depth information can achieve a shortcut to a particularly useful item of distilled information for the purpose of medical diagnostics.

[0007] A 3-D OCT data set can be reduced to generate an ocular mapping, including edema mappings and thickness mappings. Optionally, a partial fundus intensity image can be produced from the spectral domain scanning of the eye to generate an en face view of the retinal structure of the eye without first requiring a full segmentation of the 3-D OCT data. The partial intensity image is a two-dimensional en-face image extracted from a 3D OCT data block by integrating the OCT signal over a depth range greater than the axial resolution of the OCT system, but including only selected regions of the 3-D anatomical structure for integration.

[0008] The present invention can differ from conventional, time domain OCT technology because the mapping system of the present invention can be optimized to obtain the

ZM190PCT

information necessary for assessing macular edema while simultaneously producing a fundus intensity image. As part of the optimization, the present invention utilizes optimized sampling grids. For example, in the case of volume measurements of fluid-filled spaces, which require several samples spread over the areal extent of the space, a raster scan can be utilized having evenly spaced points on a square grid.

[0009] Importantly, in accordance with the present invention, the data set acquired by the spectral domain scan can contain all of the 3-D information about retinal structure needed to estimate the volumes of fluid-filled spaces. Accordingly, 3-D segmentation algorithms can be applied to the intensity data set to outline spatial structures. As yet another important aspect of the invention, intensity information can be extracted from each measured spectrum to provide an en face view or an image of the fundus that can be used immediately to judge image data quality. In this regard, an operator can then decide whether or not to take another image. Because the intensity image is generated from the same data as the subsequent 3-D data set, the intensity image provides all necessary landmarks for precisely locating on the fundus the lesions revealed by the cross-sectional OCT scan. The intensity image also provides the landmarks needed for orienting the 3-D data set to other fundus images, such as fundus photographs and fluorescein angiograms.

[0010] As an additional advantage, because the fundus intensity image can be generated before segmentation of the 3-D data set, the fundus intensity image can be used to guide the segmentation. For example, retinal blood vessels represent discontinuities in the layered retinal architecture that often disrupt segmentation of cross-sectional images. The fundus intensity image can be processed by ordinary 2-D algorithms to identify the blood vessel positions. Subsequent processing of the OCT cross-sectional images then can be modified at each vessel location. For instance, an algorithm designed to follow layers can skip past a vessel and resume segmentation on the other side of the vessel. Additional aspects of the invention will be set forth in part in the description which follows, and in part will be obvious from the description, or may be learned by practice of the invention. The aspects of the invention will be realized and attained by means of the elements and combinations particularly pointed out in the appended claims. It is to be understood that both the foregoing general description and the following detailed description are exemplary and explanatory only and are not restrictive of the invention, as claimed.

ZM190PCT

BRIEF DESCRIPTION OF THE DRAWINGS

[0011] A more complete understanding of the present invention, and the attendant advantages and features thereof, will be more readily understood by reference to the following detailed description when considered in conjunction with the accompanying drawings, wherein:

[0012] Figure 1 is a schematic illustration of an OCT imaging system configured for anatomical mapping in accordance with the present invention; and,

[0013] Figure 2 is a flow chart illustrating a process for anatomical mapping in the OCT imaging system of Figure 1.

DETAILED DESCRIPTION OF THE INVENTION

[0014] The present invention is a system, method and apparatus for anatomical mapping through the production of a 3-D data set, for instance through imagery produced utilizing OCT. In accordance with the present invention, a fundus intensity image can be acquired from a spectral domain scanning of light back-reflected from an eye. The 3-D data set can be reduced to generate an ocular mapping, including edema mappings and thickness mappings. Optionally, a partial fundus intensity image can be produced from the spectral domain scanning of the eye to generate an en face view of the retinal structure of the eye without first requiring a full segmentation of the 3-D data set.

[0015] In further illustration, Figure 1 is a schematic illustration of an OCT imaging system configured for anatomical mapping in accordance with the present invention. As shown in Figure 1, a low coherent light source 105 can be provided. The low coherent light source 105 can be a super-luminescent diode, such as a super-luminescent diode having a center wavelength sufficient to penetrate the vitreous portions of the eye 140—typically between 800 and 900 nm. In this context, those skilled in the art consider such a light source as a broadband light source. The light source 105 can be coupled to a beam splitter 115 by way of optional fiber-based isolator 110.

[0016] Specifically, the beam splitter 115 can be a 2 x 2 3dB fiber coupler configured to split light emanating from the light source 105 into sample and reference arms. The sample

ZM190PCT

arm can be coupled into the optical head of a light delivery system 165. The light delivery system 165 can include an x-y scanner 130 and optics for delivering the sample light into the eye 140 and collecting the back-reflected sample light. Optionally, the back-reflected sample light can be partially reflected through operation of a dichroic mirror 135 into a video camera 145 for real time viewing of the fundus.

[0017] By comparison to the sample arm, the reference arm can include a variable neutral density filter 125 used to adjust the reference intensity before and after the light reaches the optical reference system 170. Polarization controllers 120 can be used in both the reference and sample arms for fine tuning of the sample and reference polarization states to achieve maximal interference. In an exemplary configuration of the detection arm, a spectrometer 160 can be coupled to a line scan camera 155 to detect the combined reference and sample light. As is known in the art, a spectrometer will include an optical element such as a diffraction grating for angularly dispersing the light as a function of wavelength. The dispersed light falls on the pixels of the line scan camera. The light intensities measured by the camera pixels contain information corresponding to the distribution of reflection sites along the Z-axis depth in the sample.

[0018] Both the line scan camera 155 and the video camera 145 can be communicatively linked to a computer 150. The computer 150 can be coupled both to a data acquisition processor 190 configured to acquire data from the line scan camera 155, and also to a data reduction processor 195 configured to reduce the acquired data to produce anatomical maps 185A and partial fundus imagery 185B. The 3-D data sets would also be used to create cross-sectional OCT images 185C as known in the art.

[0019] By operation of the data acquisition processor 190, both a 3-D data set 180 and an intensity image 175 can be acquired. The intensity image 175 can be acquired in real time directly from the data acquisition processor using either digital or analog processing. Complex data processing associated with generating OCT images is not required. Consequently, an operator can discard the image if it is determined that the image is of too low quality without permitting further data processing. The 3-D data set 180, by comparison, can be produced by operation of the data reduction processor 195 from the image acquired by the data acquisition process 190. Notably, an intensity image 175 can also be derived from the 3-D data set. An intensity image created either directly from the data acquisition or from

ZM190PCT

the 3-D data set can be useful for data registration to other imaging modalities. Moreover, blood vessels can be identified as an initial step in a segmentation process. In a swept source spectral domain OCT embodiment, the output wavelength of the light source can be varied or scanned, for example, via frequency modulation. Only a single photodetector is required rather than a spectrometer and a line scan camera. The intensity data as a function of wavelength is extracted over time.

[0020] In a more particular illustration, Figure 2 is a flow chart illustrating a process for anatomical mapping in the OCT imaging system of Figure 1. Beginning first in block 210, the inherent speed of a spectral domain OCT can be utilized to sample the entire macula of an eye on a square grid. In a specific aspect of the invention, a total of 65,536 a-scans can be collected in slightly over one second by following a left-to-right, top-to-bottom scan pattern in which adjacent a-scans are separated by 23 μm , which provides adequate lateral resolution to sample fluid-filled spaces of the eye.

[0021] In block 220, a fundus image can be generated directly from intensity data included within the spectra produced by the spectral domain scan. In this regard, it is to be noted that each captured spectrum contains at least two components from which can be extracted a signal proportional to the total reflected intensity. This intensity signal can be used to produce a 2-D image of the fundus that advantageously can appear similar to the image from an SLO. Various methods can be employed to obtain the intensity signal in "real-time", so that the fundus image can be painted on a display screen as rapidly as it is acquired.

[0022] The method for extracting intensity information can be understood by considering the primary mathematical expression for the spectral intensity of the interference fringes falling on the line scan camera:

$$G_d(\nu) = G_s(\nu) \left\{ 1 + \sum_n R_{sn} + 2 \sum_{n \neq m} \sqrt{R_{sn} R_{sm}} \cos[2\pi\nu(\tau_n - \tau_m)] + 2 \sum_n \sqrt{R_{sn}} \cos[2\pi\nu(\tau_n - \tau_r)] \right\},$$

where ν is the frequency of the light; R_{sn} is the intensity reflection of a small region in the sample; $G_s(\nu)$ is the spectral density of the light source; the reflection of the reference arm is unity; distances are represented by propagation times τ_n, τ_m in the sample arm and τ_r in the reference arm and summation is across all axial depths in the sample beam. The third term in

ZM190PCT

brackets is the mutual interference for all light scattered within the sample and the last term contains the interference between the scattered sample light and the reference light from which an a-scan is calculated. It is important to note that, in embodiments where the detector is a spectrometer, the parameter ν also represents position on the line scan camera. Hence, the primary equation can be broken conceptually into two parts: the first two terms represent slow variation across the linear array of camera pixels while the last two terms represent oscillations (interference fringes). Similarly, in the embodiments where the source is swept through a range of frequencies ν the first two terms in the primary equation represent slow variation in time of the detected signal, while the last two terms represent oscillations.

[0023] The new insight that leads to generation of a fundus image is to recognize that the desired information about total reflected sample intensity resides in both the second and fourth terms of the primary equation. This permits multiple methods for extracting the intensity. The method selected for a particular application will depend on desired speed and accuracy. Several examples of methodologies for obtaining a fundus intensity image follow in which $F(x,y)$ is the output of the processing method for an a-line at scan point x,y on the fundus.

[0024] In a first example, the primary equation can be summed across ν (in practice, across the pixels of the line scan camera). Notably, the cosine terms in the primary equation which have many cycles across the spectrum will sum to (approximately) zero. Thus, applying the summation can yield

$$F(x,y) = \bar{G}_s \left(1 + \sum_n R_{sn} \right),$$

where \bar{G}_s is the total source power. The first term can, in principle, be ignored for display purposes leaving $\sum_n R_{sn}$, which is proportional to the sum of all reflected intensities in the sample, i.e., the desired fundus intensity. Digital summation of the camera output can be very fast and this method may be most suitable for painting the fundus image into a display window as rapidly as it is acquired. Various techniques can be used, if necessary, to compensate for small variations in \bar{G}_s with x,y . It is clear that other low-pass filter techniques

ZM190PCT

besides simple summation can also be applied to the primary equation to yield the above result.

[0025] In another example, the fundus intensity can also be derived from the fourth term of the primary equation by separating the oscillatory component from the slow variation and recognizing that, for retina and other low reflectance samples, the third term is small relative to the fourth term. One method to achieve this is to apply a Fourier transform to the primary equation, to discard the low frequency terms, and then to square and sum the high frequency terms. By Parseval's theorem this is equivalent in the camera output signal to high pass filtering the primary equation to remove the low frequency component, then squaring the remaining oscillatory component and summing over the spectrum.

[0026] Neglecting the third term of the equation, the high pass filtering, squaring and summing of the primary equation can produce:

$$F(x,y) = \sum_{\nu} \left\{ 2 \sum_n \sqrt{R_{sn}} G_s(\nu) \cos[2\pi\nu(\tau_n - \tau_r)] \right\}^2 = 4\bar{G}_s^2 \sum_n R_{sn} ,$$

which can be displayed directly to produce an intensity image. It is noted that one can modify the parameters of the high-pass filter in order to change the contrast of the fundus image by changing the relative contributions of shallower and deeper structures. The choice of domain in which to operate depends on considerations of speed and ease of implementation. Operations on the camera output can be carried out digitally or, for highest speed, by analog processing. Similarly, in a third exemplary method for obtaining a fundus intensity image, the observation that a spectrometer normally discards the zero order beam can be utilized such that the intensity of the zero order beam also can have the form of the equation yielded by the summation of the primary equation. Thus, the intensity signal can be obtained directly with an auxiliary photodetector and displayed with conventional methods.

[0027] Returning now to Figure 2, regardless of how the fundus intensity image is generated, in block 230 the fundus intensity image can be displayed. In this regard, the fundus intensity image can provide a plurality of benefits. First, the display of the fundus intensity image can provide immediate feedback on scan quality to the operator. Scans contaminated by eye movements, blinks or other artifacts can be repeated before data

ZM190PCT

processing. Second, because the fundus intensity image is generated from the same data as the subsequent 3-D data set, the fundus intensity image can provide all necessary landmarks for orienting the 3-D data to other fundus images, such as fundus photographs and fluorescein angiography. Third, the fundus intensity image serves to locate features that are seen in cross-sectional images.

[0028] In block 240, the acquired set of spectral domain scans can be converted into a data set that contains the axial (Z-axis) reflectance of the sample. As part of the conversion process, the acquired spectra can be transformed from points linear in wavelength to points linear in frequency (wave number). This transformation can be accomplished mathematically. Alternatively, the transformation can be accomplished by building a line scan camera that has unequally-spaced pixels. Specifically, the modified line scan camera can incorporate pixels spaced according to the reciprocal of the distance along the light detector chip in the camera. The consequent variation in pixel size will cause variation in pixel gain, but this can be compensated electronically or digitally. The transformation would therefore take place instantly in hardware, greatly speeding up the generation of the spatial data. The product of the transformation may then be used in the conversion 240 to produce a set of Z-axis intensity information data for each unique X and Y position of the beam on the sample, i.e. a 3-D data set. As noted above, this 3-D data can be converted directly into a full intensity image, for example, by squaring and summing the intensity data at each X/Y position. The 3-D data is also used to generate conventional OCT cross-sectional images 185C. The 3-D data can also be subjected to a partial segmentation process (block 250) in order to outline and quantify fluid-filled spaces and other retinal features. This segmented data can also be used (block 260), to generate ocular maps, such as “edema maps” and “thickness maps” that can be used for diagnosis and treatment. The partial segmentation can also be used to generate a partial fundus image. The partial fundus image is generated the same way as the full fundus image from the 3-D data however, the depth location and range around that depth is limited and selected through the segmentation process. As discussed below, a partial fundus image can be created to highlight certain features or landmarks in the eye. Note that a full segmentation process would be one that identifies many (or all) retinal layers and/or structures. A partial fundus image requires finding only one surface, either a specific retinal layer, like the retinal pigment epithelium, or

ZM190PCT

a more general description of retinal tilt and curvature such as the locus of the centroids of each a-scan.

[0029] Notably, the retina can be tilted and curved with respect to the Cartesian coordinate system of the acquired 3-D data set. Reference surfaces identified during segmentation can be used as boundaries to create a partial intensity image that help identify the tilt and curvature. The reference surfaces can capture this tilt and curvature as mathematical surfaces within the acquired data set. These reference surfaces can be generated by combining lines segmented on individual longitudinal cross sectional scans (B-scans). Reference surfaces also can typically correspond to known anatomical layers of the retina. Likely examples include the retinal pigment epithelium (RPE) and the inner limiting membrane (ILM). The reference surfaces can be used to visualize pathology or to define layers within the data set that have the variation due to retinal tilt and curvature removed. Data points within these layers can be used to form en face images or partial intensity images that represent retinal structures localized to a particular depth or anatomic layer.

[0030] A characteristic of the data set for the partial fundus intensity image is that it has thickness, in general greater than the axial resolution of the OCT. This and the fact that the layer is curved and tilted in a way intended to capture anatomy distinguishes it from "C-scans"--the tangential slices produced by SLO/OCT instruments--which are perpendicular to the scanning beam. Hence, C-scans are thin, the thickness being defined by the axial resolution, and they are not usually aligned with retinal structures.

[0031] Specifically, intensity in axial scans can be expressed as

$$I(\tau) = 2 \sum_n \sqrt{R_n} \Gamma[\tau \pm 2(\tau_n - \tau_r)],$$

where distance along the z-axis is represented by propagation time $\tau = nz / c$ with n the refractive index of tissue and c the speed of light in vacuum; τ_n and τ_r are the propagation times for light reflected by the nth scatterer in the sample and the reference mirror, respectively; R_n is the normalized intensity reflection of the nth scatterer; and summation is across all axial depths in the sample beam. $\Gamma(\tau)$ is the autocorrelation function of the light source and expresses the axial resolution of the system. Note $\Gamma[\tau \pm 2(\tau_n - \tau_r)]$ falls rapidly

ZM190PCT

to zero as $(\tau_n - \tau_r)$ becomes greater than the axial resolution. For each depth τ , therefore, the reflected intensity comes from only a thin layer of the R_n .

[0032] Thus, a tissue layer defined as above can be expressed by its upper boundary $\tau_0(x, y)$ and lower boundary $\tau_1(x, y)$. The total reflectance of the scatterers in the tissue layer at each point (x, y) can be obtained by squaring

$$I(\tau) = 2 \sum_n \sqrt{R_n} \Gamma[\tau \pm 2(\tau_n - \tau_r)],$$

and then summing from τ_0 to τ_1 . The result is the desired partial fundus intensity image

$$F(x, y) = \sum_{\tau_0}^{\tau_1} \left\{ 2 \sum_n \sqrt{R_n} \Gamma[\tau \pm 2(\tau_n - \tau_r)] \right\}^2.$$

[0033] Still, it is to be understood that the partial fundus intensity image (as well as the fundus intensity image) can be obtained without the explicit use of the above equation. In fact, any monotonic transformation of the a-line intensities, when summed, can produce an apparent partial fundus intensity image, though the relative intensities of the different structures can differ. For example, the squaring step can be omitted prior to the summing step and the resulting partial fundus intensity image can suffice. In fact, performing a monotonic transformation, strictly speaking, is not required as a transformation having a "little wiggle" can provide a similar result. Notwithstanding, the above equation can provide a true intensity and serves as a preferred example of the technique. Note that the generation of a partial fundus image need not be restricted to a summation between two surfaces, but could also be defined by an integral under a z-profile that followed the reference surface, (e.g., the two surface example defines a rectangular z-profile).

[0034] The partial fundus intensity image can be applied to the registration of OCT with other modalities. Specifically, in addition to its use for display of pathology, a partial fundus intensity image can be used to provide high contrast images of the retinal blood vessels that are useful for aligning the OCT data set to images from other clinical modalities (such as fundus photographs). Due to scattering by red blood cells, major retinal blood vessels cast

ZM190PCT

strong shadows onto the underlying tissue. By placing one boundary of the slab a distance below the ILM that excludes the light scattered by the blood vessels themselves, then forming the partial fundus intensity image from all tissue below that boundary, these shadows are emphasized and the blood vessel pattern stands out in stark relief against the brighter retinal reflection. This type of partial fundus intensity image can be referred to as a shadowgram as other partial fundus intensity images can be used to emphasize intra-retinal or sub-retinal structures by the reflected light of the structures rather than the shadows produced by the incidence of light upon the structures.

[0035] The fundus intensity image also solves the specific problem of image registration for assessment of the retinal nerve fiber layer in glaucoma diagnosis. In the case of the retinal nerve fiber layer, more accurate registration will reduce measurement variance and improve the detection of glaucoma progression.

[0036] The method of the present invention can be realized in hardware, software, or a combination of hardware and software. An implementation of the method of the present invention can be realized in a centralized fashion in one computer system, or in a distributed fashion where different elements are spread across several interconnected computer systems. Any kind of computer system, or other apparatus adapted for carrying out the methods described herein, is suited to perform the functions described herein.

[0037] A typical combination of hardware and software could be a general purpose computer system with a computer program that, when being loaded and executed, controls the computer system such that it carries out the methods described herein. The present invention can also be embedded in a computer program product, which comprises all the features enabling the implementation of the methods described herein, and which, when loaded in a computer system, is able to carry out these methods.

[0038] Computer program or application in the present context means any expression, in any language, code or notation, of a set of instructions intended to cause a system having an information processing capability to perform a particular function either directly or after either or both of the following a) conversion to another language, code or notation; b) reproduction in a different material form. Significantly, this invention can be embodied in other specific forms without departing from the spirit or essential attributes thereof, and

ZM190PCT

accordingly, reference should be had to the following claims, rather than to the foregoing specification, as indicating the scope of the invention.

ZM190PCT

The following references are incorporated herein by reference:

US PATENT DOCUMENTS

US5321501
US5459570
US5975697
US6769769
US20040036838
US20040233457

FOREIGN PATENT DOCUMENTS

CA2390072
WO2004102112

OTHER PUBLICATIONS

Bower, B.A. et al. "Rapid Volumetric Imaging of the Human Retina *in vivo* Using a Low-Cost, Spectral-Domain Optical Coherence Tomography System" ARVO annual meeting, May 02, 2005, 8:45 AM - 9:00 AM, #1050

Choma, M. A. et al. (2003). "Sensitivity advantage of swept source and Fourier domain optical coherence tomography." Optics Express 11(18): 2183-2189

de Boer, J.F. et al. "Ultra-High Speed and Ultra-High Resolution Structural, Flow Velocity, and Polarization Sensitive Sd/Fd-Oct of the Human Retina" ARVO annual meeting, May 02, 2005, 12:15 PM -12:30 PM, #1116

Ferguson, R.D. et al. "Enhanced Retinal Imaging With Tracking Optical Coherence Tomography (TOCT)" ARVO annual meeting, May 02, 2005, 12:45 PM - 1:00 PM, #1118

ZM190PCT

Fujimoto, J. "Advances in High Resolution and Spectral OCT" Ocular Imaging 2005, Palm Beach, Florida, Dec. 4, 2005, 11:00am

Gregori, G. et al. "3-D OCT Maps of Retinal Pathologies" ARVO annual meeting, May 02, 2005, 10:00 AM -10:15 AM, #1055

Hitzenberger, C. K. et al. (2003). "Three-dimensional imaging of the human retina by high-speed optical coherence tomography." *Optics Express* 11(21): 2753-2761

Huang, D. et al. (1991). "Optical coherence tomography." *Science* 254(5035): 1178-81

Izatt, J. A. et al. (1993). "Ophthalmic diagnostics using optical coherence tomography". *Ophthalmic Technologies III*, SPIE, 1877: 136-144, Los Angeles, CA, USA

Jiao, S., et al. "Simultaneous acquisition of sectional and fundus ophthalmic images with spectral-domain optical coherence tomography" Photonics West, Jan 22, 2005, Ophthalmic Technologies XV, Program # 5688-81.

Jiao, S. et al. (2005) "Simultaneous acquisition of sectional and fundus ophthalmic images with spectral-domain optical coherence tomography" *Optics Express* 13, 444-452,

Jiao, S. et al. "Macula Mapping and Simultaneous Acquisition of Sectional and Fundus Ophthalmic Images With Three-Dimensional Spectral-Domain Optical Coherence Tomography" ARVO annual meeting, May 02, 2005, 11:45 AM -12:00 PM, #1114

Ko, T.H. et al. "Three Dimensional Retinal Imaging of Small Animals With High-speed, Ultrahigh Resolution Optical Coherence Tomography" ARVO annual meeting, May 02, 2005, 9:00 AM - 9:15 AM, #1051

ZM190PCT

Puliafita C. A. "Summary and Significance" American Academy of Ophthalmology Subspecialty Day on retina, Section X: Ocular Imaging, New Orleans, Oct. 23, 2004, 3:06 pm

Sacu, S. et al. "Imaging of Pigment Epithelial Disease Using Threedimensional (3D) Ultrahigh Resolution (UHR) Optical Coherence Tomography (OCT)" ARVO annual meeting, May 03, 2005, 11:15 AM - 1:00 PM, # 2563/B116

Schmidt-Erfurth, U.M. et al. "Three-Dimensional Ultrahigh Resolution Optical Coherence Tomography (3D UHR OCT): A Video Presentation" ARVO annual meeting, May 02, 2005, 12:00 PM -12:15 PM, #1115

Scholda, C.D. et al. "Visualization of the Vitreoretinal Interface Using Three-Dimensional Ultrahigh Resolution Optical Coherence Tomography" ARVO annual meeting, May 02, 2005, 9:45 AM -10:00 AM, #1054

Sharp, P. F. et al (2004) "The scanning laser ophthalmoscope—a review of its role in bioscience and medicine" Physics in Medicine and Biology 49: 1085-1096)

Srinivasan, V.J. et al. "Intraretinal Thickness Mapping using Three-Dimensional, High-Speed Ultrahigh Resolution OCT" ARVO annual meeting, May 02, 2005, 11:30 AM -11:45 AM, #1113

Swanson, E. A. et al. (1993). "In-vivo retinal imaging by optical coherence tomography." Optics Letters 18(21): 1864-1866;

Werner, J.S. et al. "Three-Dimensional Retinal Imaging With High Speed and High Resolution OCT" ARVO annual meeting, May 02, 2005, 9:15 AM - 9:30 AM, #1052

ZM190PCT

Claims:

1. An apparatus for obtaining images of an object comprising:
 - a spectral domain optical coherence tomography (OCT) system, said system including a light source, a beam splitter for dividing the light along a sample path and a reference path, said sample path further including a scanner for scanning the light in at least one of the X and Y directions over the sample;
 - a detector for receiving light returned from both the sample and the reference paths and generating a plurality of sets of outputs, each set corresponding to varying intensities at different wavelengths of said source at a particular X /Y position of said light on said sample, said intensities including information about the reflection distribution along the sample in the Z axis; and
 - a processor for directly converting each set of outputs into a single intensity value corresponding to the integrated intensity in the Z axis for the associated X/Y position of the light on the sample, said single intensity values being suitable for generating a two dimensional image intensity map of the object.
2. An apparatus as recited in claim 1, further including a monitor for displaying the intensity values as a two dimensional intensity map.
3. An apparatus as recited in claim 1, wherein said processor converts the detector outputs to intensity values by one of (a) summing the outputs, (b) squaring and then summing the outputs, (c) high pass filtering or high pass filtering and then squaring and summing the results.
4. An apparatus as recited in claim 1, wherein the two dimensional intensity map is used to register an image obtained with another imaging modality.
5. An apparatus as recited in claim 1, wherein the processor further converts the detector outputs into a 3-D data set with Z-axis intensity information for each X/Y position, said 3-D data sets being suitable for generating OCT cross-sectional images.

ZM190PCT

6. An apparatus as recited in claim 5, wherein the two dimensional intensity map is used to register an OCT cross-sectional image.
7. An apparatus as recited in claim 5, wherein the intensity map is displayed in parallel with an OCT cross-sectional image.
8. An apparatus as recited in claim 5, wherein the processor further functions to segment the 3-D data sets based on landmarks.
9. An apparatus as recited in claim 8, wherein the landmarks are identified from the information generated from the intensity map.
10. An apparatus as recited in claim 8, wherein the landmarks include a pair of physical boundaries within the sample.
11. An apparatus as recited in claim 8, wherein the segmented data is used to generate a partial intensity image.
12. An apparatus as recited in claim 8, wherein the segmented data is used to generate an ocular map.
13. An apparatus as recited in claim 8, wherein the segmented data is used to quantify fluid filled spaces.
14. An apparatus as recited in claim 1, wherein the light source is a broadband light source and the detector is a spectrometer.
15. An apparatus as recited in claim 13, wherein the spectrometer includes a grating and a detector array.

ZM190PCT

16. An apparatus as recited in claim 1, wherein the source is tunable and swept and intensity at different wavelengths is obtained over time.

17. An apparatus for obtaining images of an object comprising:

a spectral domain optical coherence tomography (SD-OCT) system, said system including a scanner for scanning a light beam in at least one of the X and Y directions over the sample, said system being one of a swept source SD-OCT system and a spectrometer based SD-OCT system, said system generating a plurality of sets of outputs, each set corresponding to varying intensities at different wavelengths of said source at a particular X /Y position of said light on said sample, said intensities including information about the reflection distribution along the sample in the Z axis; and

a processor for directly converting each set of outputs into a single intensity value corresponding to the integrated intensity in the Z axis for the associated X/Y position of the light on the sample, said single intensity values being suitable for generating a two dimensional image intensity map of the object.

18. An apparatus as recited in claim 17, further including a monitor for displaying the intensity values as a two dimensional intensity map.

19. An apparatus as recited in claim 17, wherein said processor converts the detector outputs to intensity values by one of (a) summing the outputs, (b) squaring and then summing the outputs, (c) high pass filtering or high pass filtering and then squaring and summing the results.

20. An apparatus as recited in claim 17, wherein the light source is a broadband light source and the detector is a spectrometer.

21. A method of generating intensity images of an object utilizing outputs generated by a spectral domain optical coherence tomography (SD-OCT) system, said system including a scanner for scanning a light beam in at least one of the X and Y directions over

ZM190PCT

the sample, said system being one of a swept source SD-OCT system and a spectrometer based SD-OCT system, said system generating a plurality of sets of outputs, each set corresponding to varying intensities at different wavelengths of said source at a particular X/Y position of said light on said sample, said intensities including information about the reflection distribution along the sample in the Z axis, said method comprising the steps of:

- directly converting each set of outputs into a single intensity value corresponding to the integrated intensity in the Z axis for the associated X/Y position of the light on the sample; and
- generating a two-dimensional intensity map of the integrated intensity values.

22. A method as recited in claim 21, further including the step of displaying the intensity map on a monitor.

23. A method as recited in claim 21, wherein the step of converting outputs into single intensity values is performed by one of (a) summing the outputs, (b) squaring and then summing the outputs, (c) high pass filtering or high pass filtering and then squaring and summing the results.

24. A method as recited in claim 21, further including the step of using the two dimensional intensity map to register an image obtained with another imaging modality.

25. A method as recited in claim 21, further including the step of converting the detector outputs into a 3-D data set with Z-axis intensity information for each X/Y position, said 3-D data sets being suitable for generating OCT cross-sectional images.

26. A method as recited in claim 25, further including the step of using the two dimensional intensity map to register an OCT cross-sectional image.

27. A method as recited in claim 25, further including the step of displaying the intensity map in parallel with an OCT cross-sectional image.

ZM190PCT

28. A method as recited in claim 25, further including the step of segmenting the 3-D data sets based on landmarks.

29. A method as recited in claim 25, wherein the landmarks are identified from the information generated from the intensity map.

30. A method as recited in claim 25, wherein the landmarks include a pair of physical boundaries within the sample.

31. A method as recited in claim 25, wherein the segmented data is used to generate a partial intensity image.

32. A method as recited in claim 25, wherein the segmented data is used to generate an ocular map.

33. A method as recited in claim 25, wherein the segmented data is used to quantify fluid filled spaces.

34. An apparatus for obtaining images of an object comprising:
a spectral domain optical coherence tomography (OCT) system, said system including a light source, a beam splitter for dividing the light along a sample path and a reference path, said sample path further including a scanner for scanning the light in at least one of the X and Y directions over the sample;
a detector for receiving light returned from both the sample and the reference paths and generating a plurality of sets of outputs, each set corresponding to varying intensities at different wavelengths of said source at a particular X/Y position of said light on said sample, said intensities including information about the reflection distribution along the sample in the Z axis; and
a processor for converting the outputs of each set of outputs into a 3-D data set including Z-axis intensity information for each X/Y position, said 3-D data sets being suitable for generating OCT cross-sectional images, said processor further for

ZM190PCT

converting at least some of the 3-D data sets into a single intensity value corresponding to the integrated intensity across at least a portion of the Z axis for the associated X/Y position of the light on the sample, said single intensity values being suitable for generating a two dimensional image intensity map of the object.

35. An apparatus as recited in claim 34, further including a monitor for displaying the intensity values as a two dimensional intensity map.

36. An apparatus as recited in claim 34, wherein the two dimensional intensity map is used to register an OCT cross-sectional image.

37. An apparatus as recited in claim 34, wherein the intensity map is displayed in parallel with an OCT cross-sectional image.

38. An apparatus as recited in claim 34, wherein the two dimensional intensity map is used to register an image obtained with another imaging modality.

39. An apparatus as recited in claim 34, wherein the processor further functions to segment the 3-D data sets based on landmarks.

40. An apparatus as recited in claim 39, wherein the landmarks are identified from the information generated from the intensity map.

41. An apparatus as recited in claim 39, wherein the landmarks include a pair of physical boundaries within the sample.

42. An apparatus as recited in claim 39, wherein the segmented data is used to generate a partial intensity image.

43. An apparatus as recited in claim 34, wherein the light source is a broadband light source and the detector is a spectrometer.

ZM190PCT

44. An apparatus for obtaining images of an object comprising:
a spectral domain optical coherence tomography (SD-OCT) system, said system including a scanner for scanning a light beam in at least one of the X and Y directions over the sample, said system being one of a swept source SD-OCT system and a spectrometer based SD-OCT system, said system generating a plurality of sets of outputs, each set corresponding to varying intensities at different wavelengths of said source at a particular X /Y position of said light on said sample, said intensities including information about the reflection distribution along the sample in the Z axis; and
a processor for converting the outputs of each set of outputs into a 3-D data set including Z-axis intensity information for each X/Y position, said 3-D data sets being suitable for generating OCT cross-sectional images, said processor further for converting at least some of the 3-D data sets into a single intensity value corresponding to the integrated intensity across at least a portion of the Z axis for the associated X/Y position of the light on the sample, said single intensity values being suitable for generating a two dimensional image intensity map of the object.

45. An apparatus as recited in claim 44, further including a monitor for displaying the intensity values as a two dimensional intensity map.

46. An apparatus as recited in claim 44, wherein the two dimensional intensity map is used to register an OCT cross-sectional image.

47. An apparatus as recited in claim 44, wherein the intensity map is displayed in parallel with an OCT cross-sectional image.

48. An apparatus as recited in claim 44, wherein the two dimensional intensity map is used to register an image obtained with another imaging modality.

ZM190PCT

49. An apparatus as recited in claim 44, wherein the processor further functions to segment the 3-D data sets based on landmarks.

50. An apparatus as recited in claim 49, wherein the landmarks are identified from the information generated from the intensity map.

51. An apparatus as recited in claim 49, wherein the landmarks include a pair of physical boundaries within the sample.

52. An apparatus as recited in claim 49, wherein the segmented data is used to generate a partial intensity image.

53. An apparatus as recited in claim 44, wherein the light source is a broadband light source and the detector is a spectrometer.

54. A method of generating intensity images of an object utilizing the output from a spectral domain optical coherence tomography (SD-OCT) system, said system including a scanner for scanning a light beam in at least one of the X and Y directions over the sample, said system being one of a swept source SD-OCT system and a spectrometer based SD-OCT system, said system generating a plurality of sets of outputs, each set corresponding to varying intensities at different wavelengths of said source at a particular X /Y position of said light on said sample, said intensities including information about the reflection distribution along the sample in the Z axis, said method comprising the steps of:

converting the outputs of each set of outputs into a 3-D data set including Z-axis intensity information for each X/Y position, said 3-D data sets being suitable for generating OCT cross-sectional images;

converting at least some of the 3-D data sets into a single intensity value corresponding to the integrated intensity across at least a portion of the Z axis for the associated X/Y position of the light on the sample; and

generating a two dimensional image map of the integrated intensity values.

ZM190PCT

55. A method as recited in claim 54, further including the step of displaying the intensity map on a monitor.

56. A method as recited in claim 54, further including the step of using the two dimensional intensity map to register an OCT cross-sectional image.

57. A method as recited in claim 54, further including the step of displaying the intensity map in parallel with an OCT cross-sectional image.

58. A method as recited in claim 54, further including the step of using the two dimensional intensity map to register an image obtained with another imaging modality.

59. A method as recited in claim 54, further including the step of segmenting the 3-D data sets based on landmarks.

60. A method as recited in claim 59, wherein the landmarks are identified from the information generated from the intensity map.

61. A method as recited in claim 59, wherein the landmarks include a pair of physical boundaries within the sample.

62. A method as recited in claim 59, wherein the segmented data is used to generate a partial intensity image.

63. An apparatus for obtaining images of an object comprising:
a spectral domain optical coherence tomography (OCT) system, said system including a broad band light source, a beam splitter for dividing the light along a sample path and a reference path, said sample path further including a scanner for scanning the light in at least one of the X and Y directions onto the sample;
a detector for receiving light returned from both the sample and the reference paths, said detector including a spectrometer and a line scan camera for generating a

ZM190PCT

plurality of sets of outputs, each set corresponding to varying intensities at different wavelengths of said source at a particular X /Y position of said light on said sample, said intensities including information about the reflection distribution along the sample in the Z axis, said detector further including an auxiliary detector element for monitoring zero order light and generating an output corresponding to the integrated intensity in the Z axis for the associated X/Y position of the light on the sample; and

a processor for converting each set of outputs from the line scan camera into a 3-D data sets including Z-axis intensity information for each X/Y position, said 3-D data sets being suitable for generating cross-sectional images, said processor for converting the outputs from the auxiliary detector element into a format suitable for generating a two dimensional image intensity map of the object.

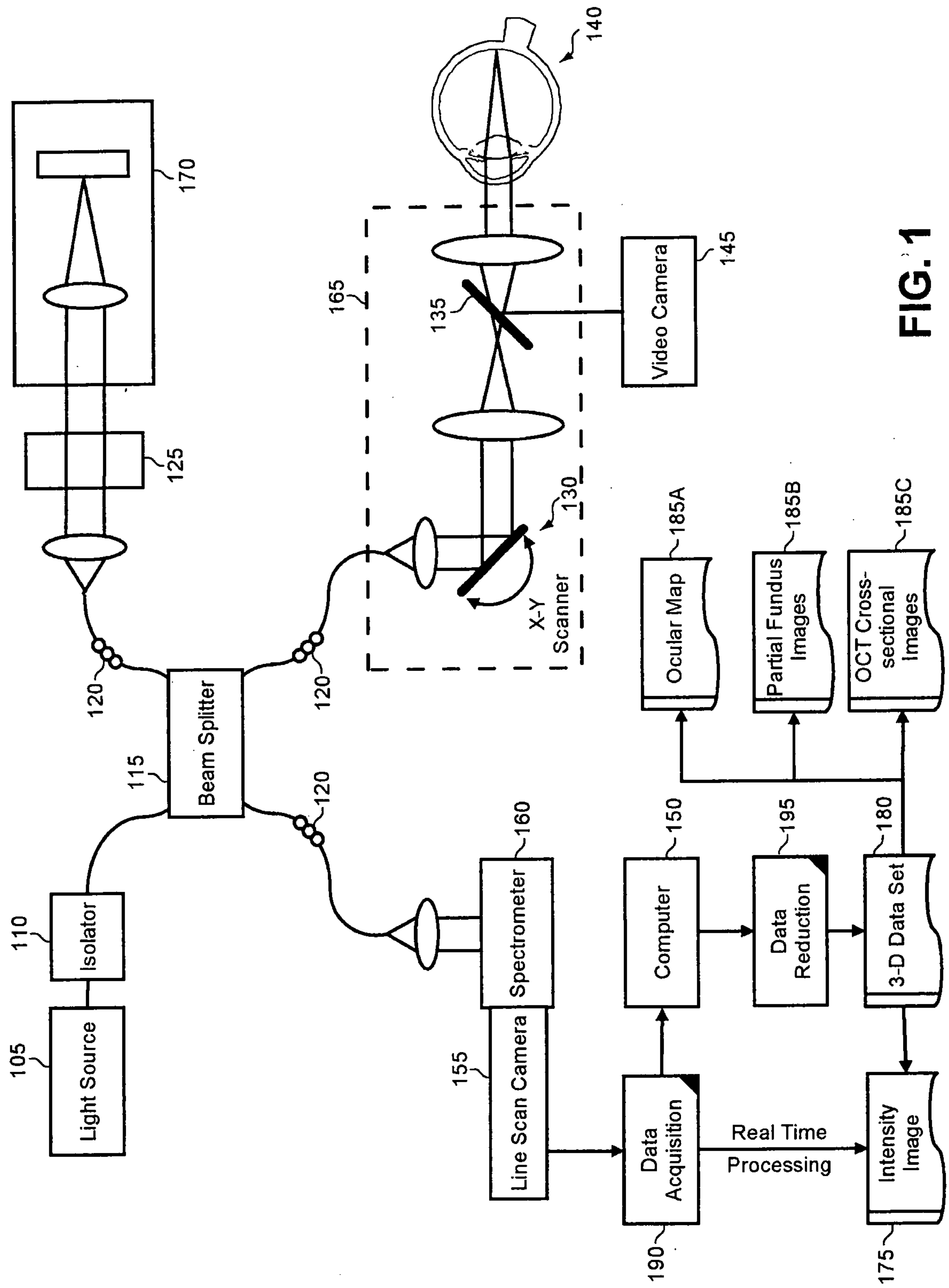

FIG. 1

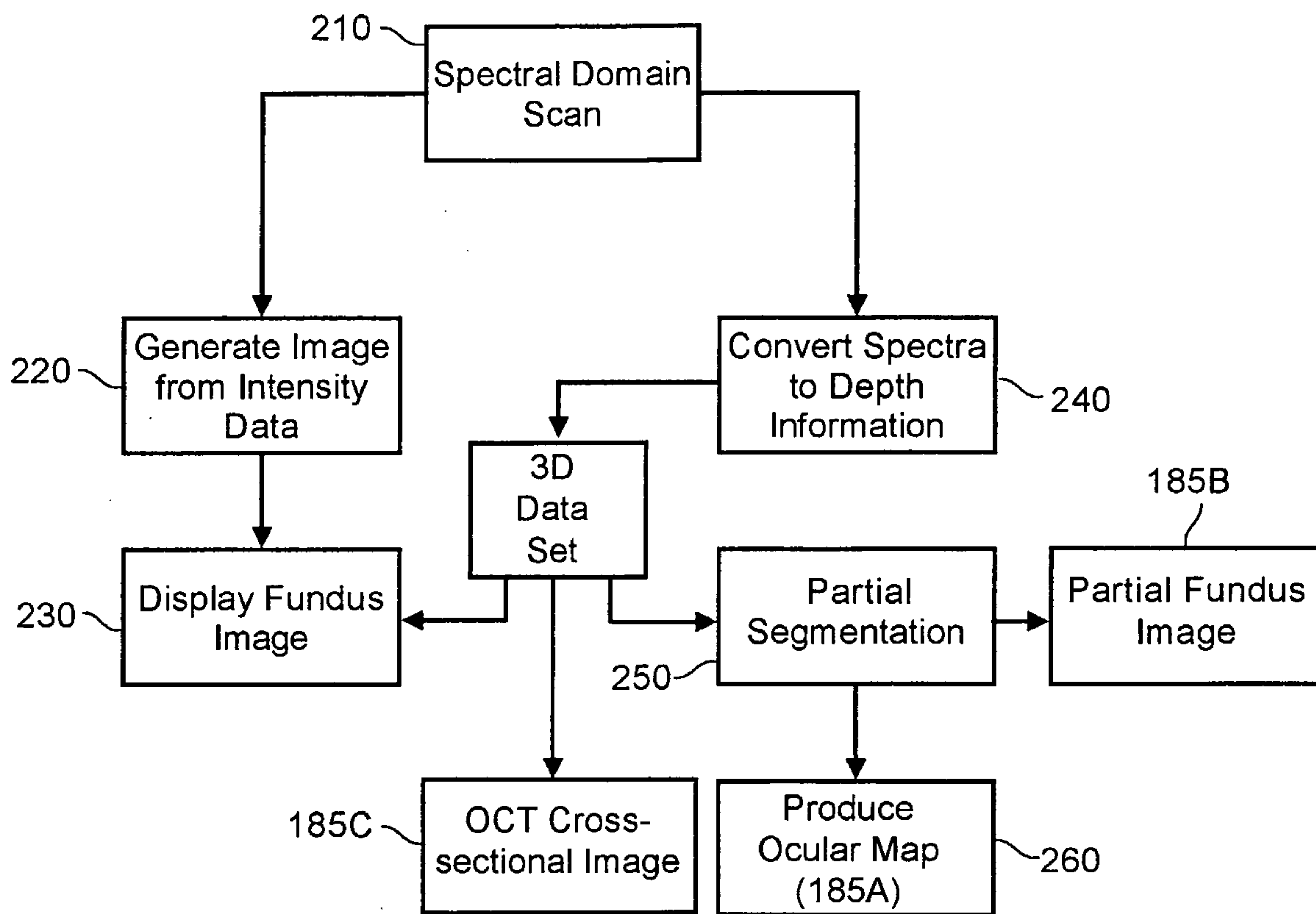

FIG. 2

