



US006111555A

**United States Patent** [19]  
**Haas**

[11] **Patent Number:** **6,111,555**  
[45] **Date of Patent:** **Aug. 29, 2000**

[54] **SYSTEM AND METHOD FOR DRIVING A FLAT PANEL DISPLAY AND ASSOCIATED DRIVER CIRCUIT**

[75] Inventor: **Andrew M. Haas**, Perrysburg, Ohio

[73] Assignee: **Photonics Systems, Inc.**, Northwood, Ohio

[21] Appl. No.: **09/022,515**

[22] Filed: **Feb. 12, 1998**

[51] **Int. Cl.**<sup>7</sup> ..... **G09G 3/20**

[52] **U.S. Cl.** ..... **345/60; 345/63; 345/68**

[58] **Field of Search** ..... **345/60, 55, 50, 345/51, 67, 87, 98, 100, 103, 95, 93, 63, 68**

[56] **References Cited**

**U.S. PATENT DOCUMENTS**

5,081,400	1/1992	Weber et al. .	
5,307,084	4/1994	Yamaguchi et al. ....	345/87
5,359,343	10/1994	Nakamura .....	345/100
5,438,290	8/1995	Tanaka .	
5,546,102	8/1996	Sheffer et al. ....	345/100
5,654,728	8/1997	Kanazawa et al. .	
5,864,328	1/1999	Kajimoto .....	345/95

**OTHER PUBLICATIONS**

S. Mikoshiba, "Seminars M4: Color Plasma Displays," Society for Information Display (SID), 1997.

S. Mikoshiba, Society for Information Display, "Color Plasma Displays", Seminars M-4, The University of Electro-Communications, Tokyo, Japan "Afix all types of . . ." Jan. 1.

*Primary Examiner*—Steven J. Saras  
*Assistant Examiner*—Alech D. Nelson  
*Attorney, Agent, or Firm*—Marshall & Melhorn

[57] **ABSTRACT**

A system and method for driving a flat panel display are provided. The system includes a register connected to a latch having outputs connected to logic circuits which correspond to the electrodes. Each logic circuit is also connected to the register, and generates control signals based on the next state and the current state of the corresponding electrode. Each logic circuit is configured such that upon an activation signal, the logic circuit control signals connect the change up driver to electrodes having a low current state and a high next state, and connect the change down driver to electrodes having a high current state and a low next state.

**6 Claims, 6 Drawing Sheets**

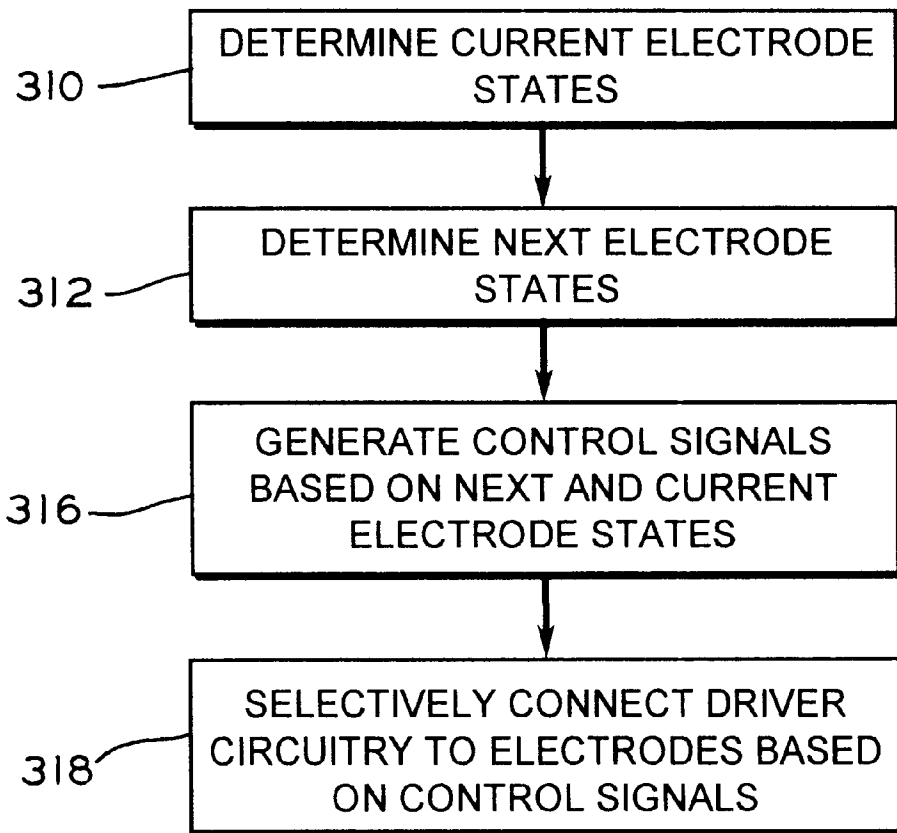

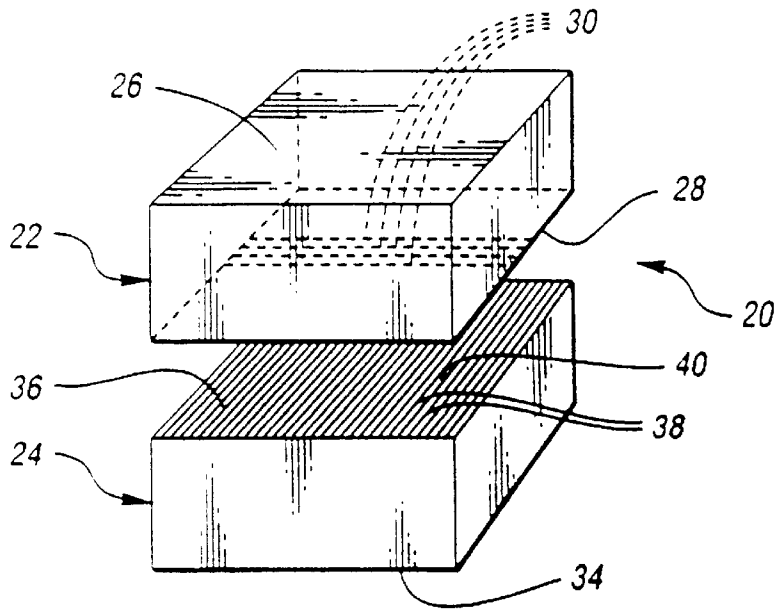

FIG. 1

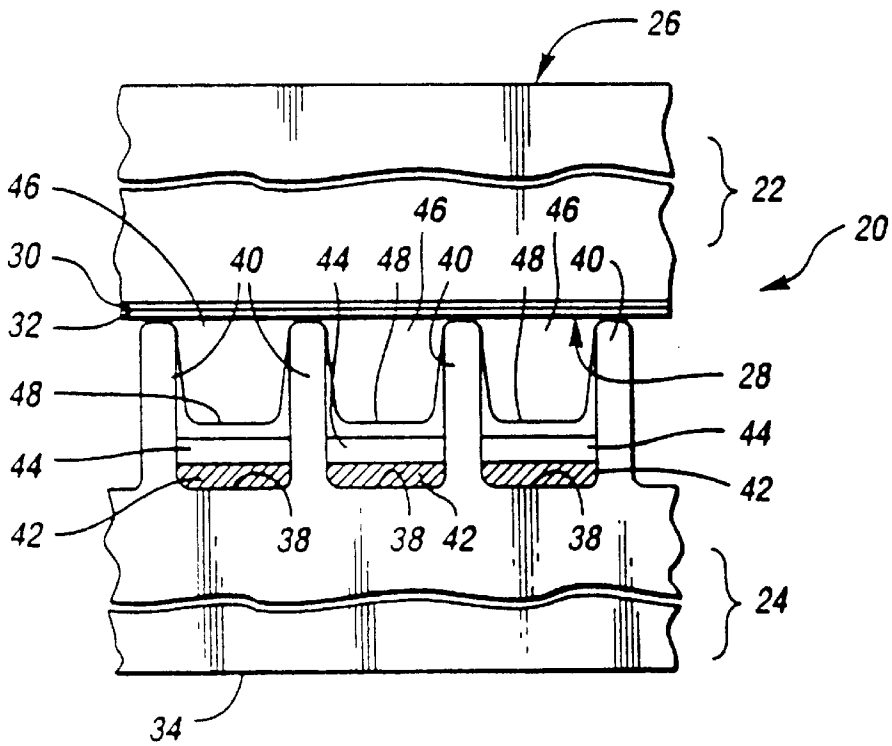

FIG. 2

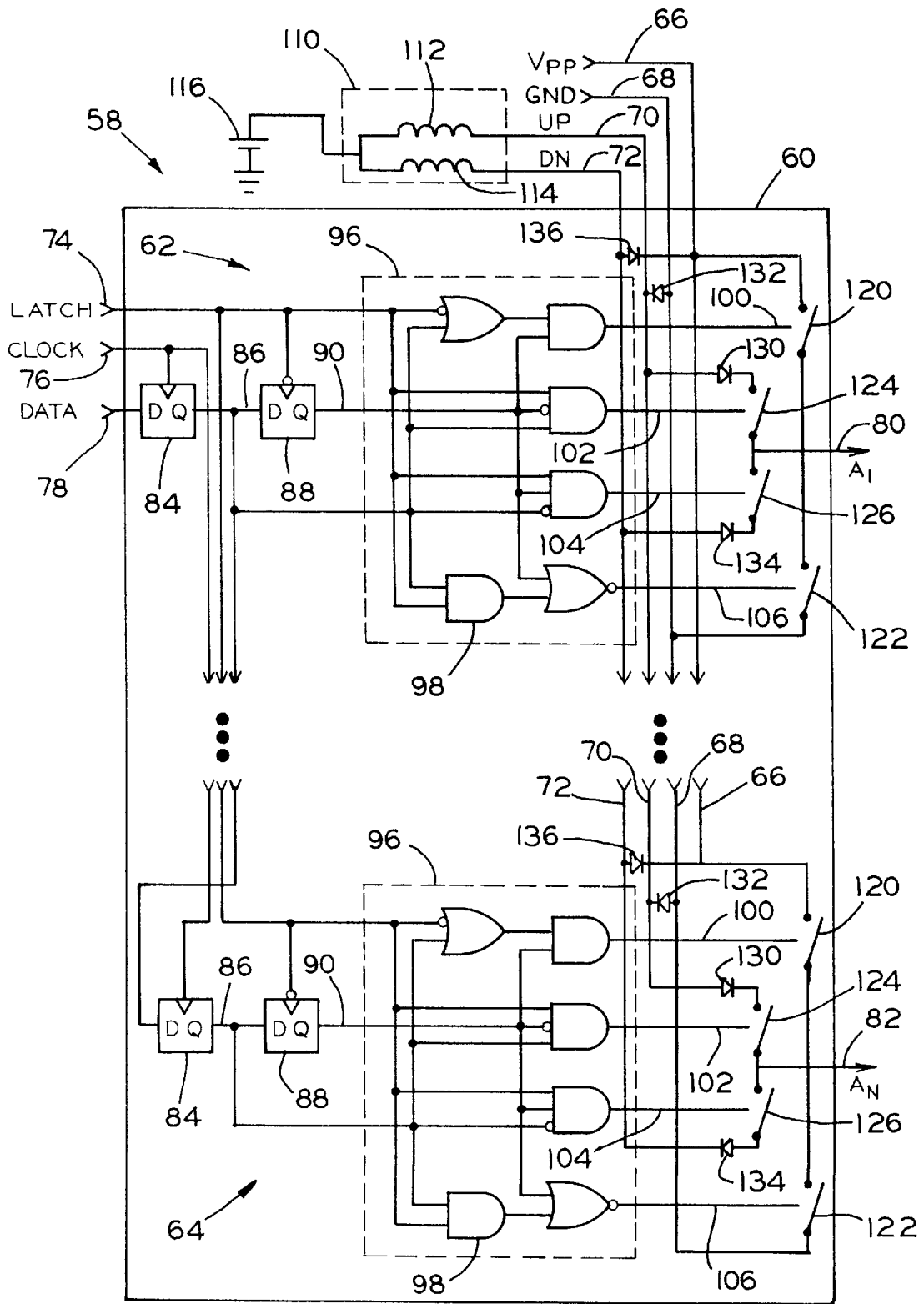

FIG. 3

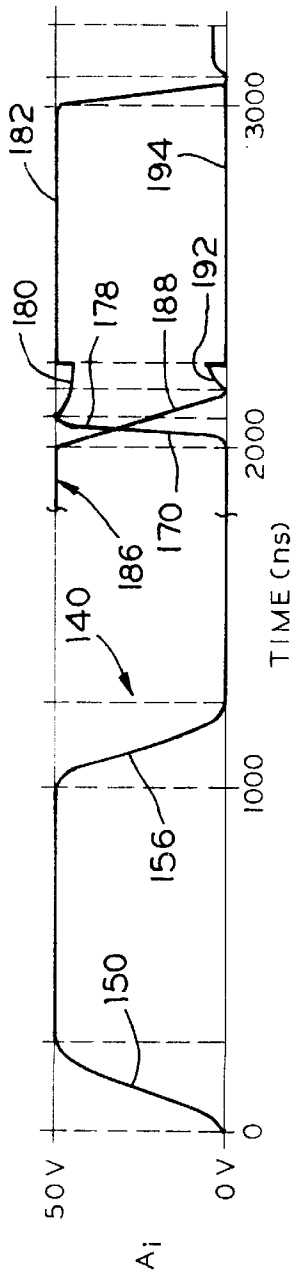

FIG. 4a

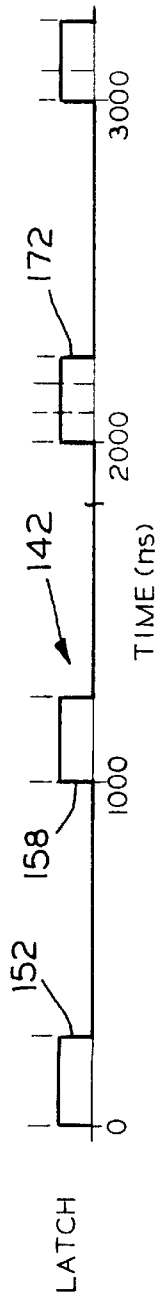

FIG. 4b

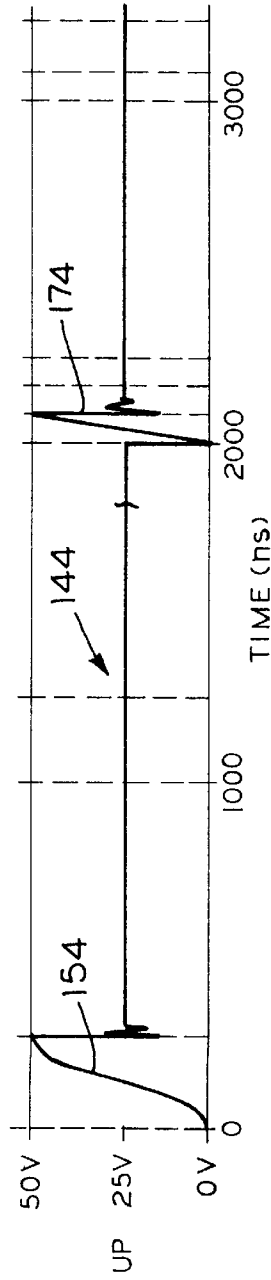

FIG. 4c

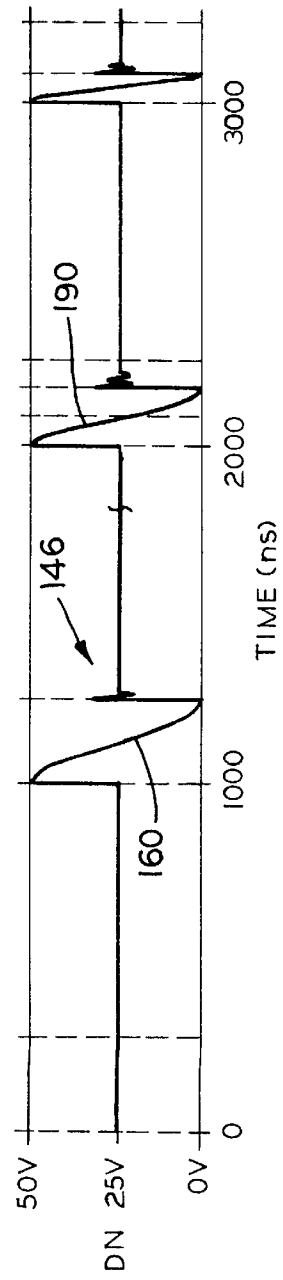

FIG. 4d

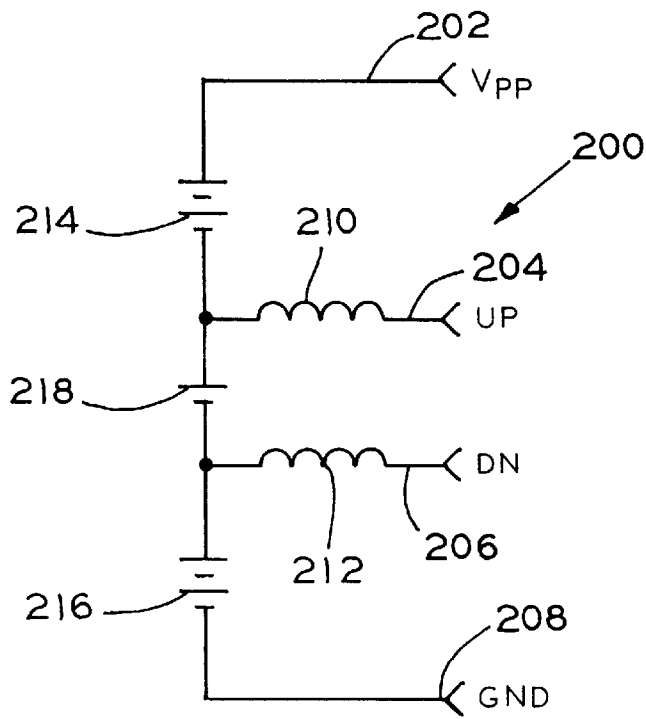

FIG. 5

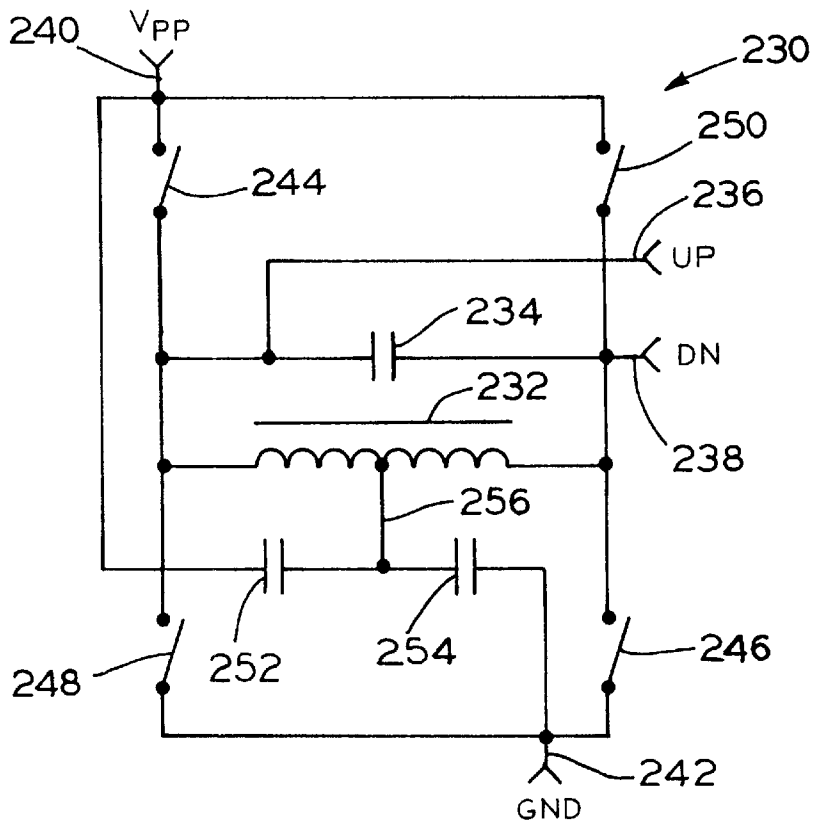
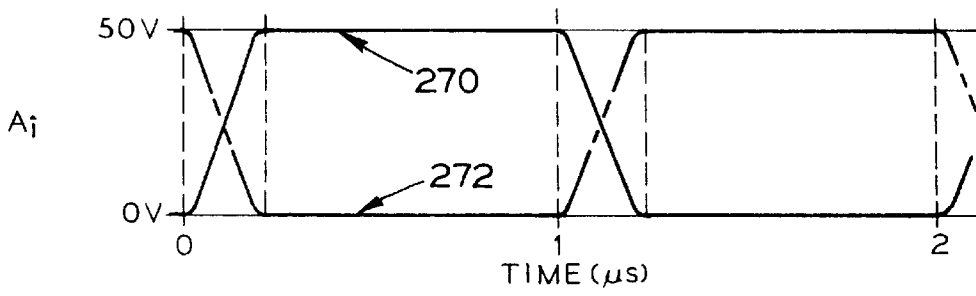
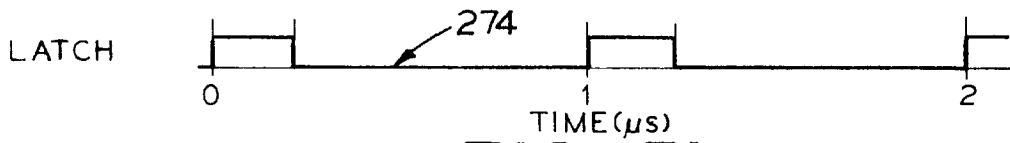

FIG. 6



**FIG. 7a**



**FIG. 7b**

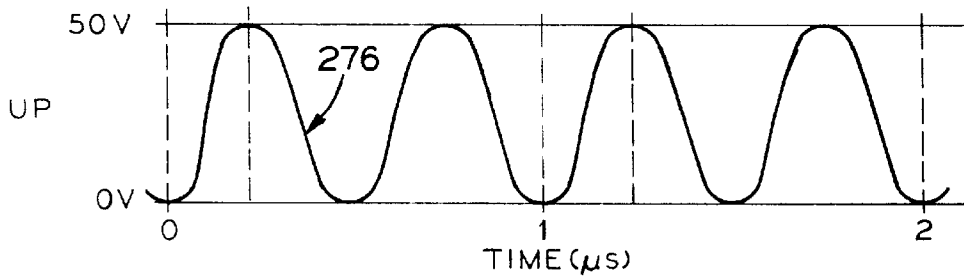

**FIG. 7c**

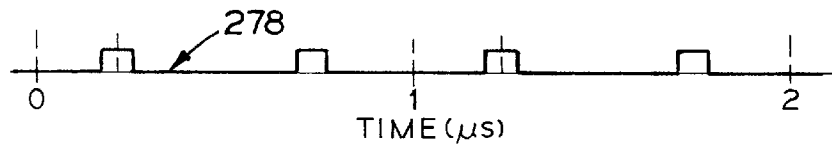

**FIG. 7d**

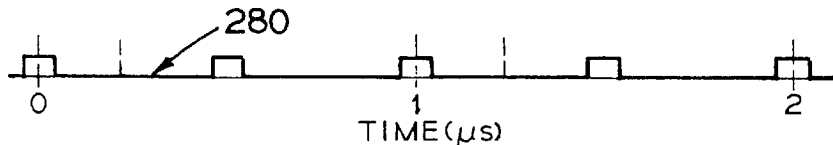

**FIG. 7e**

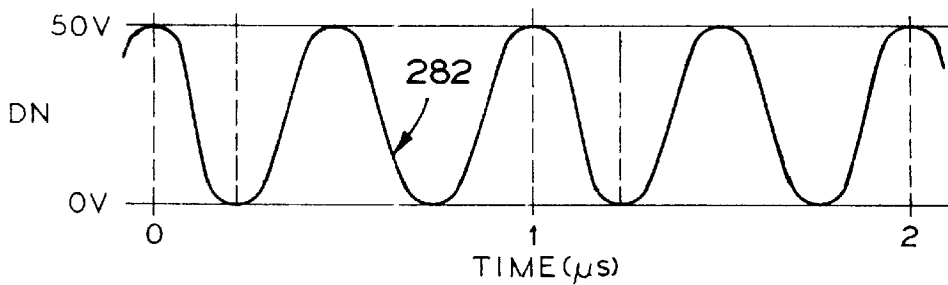

**FIG. 7f**

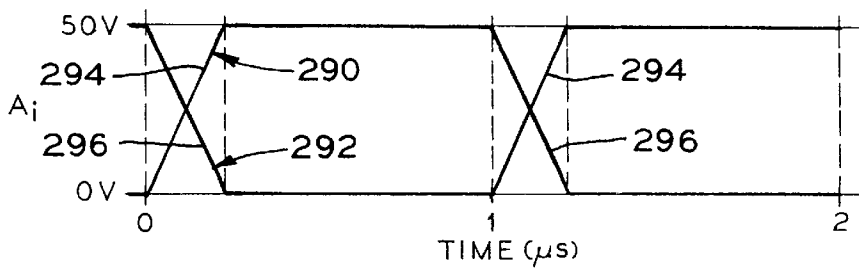

FIG. 8a

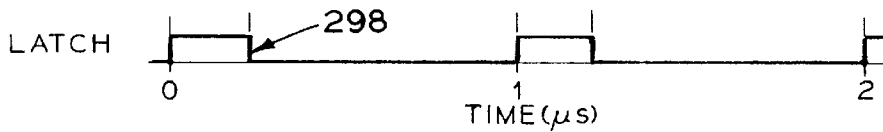

FIG. 8b

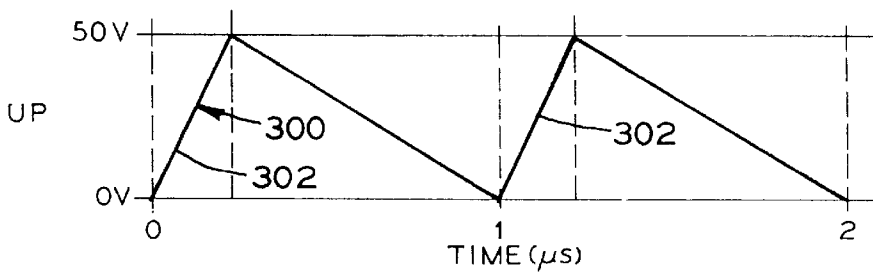

FIG. 8c

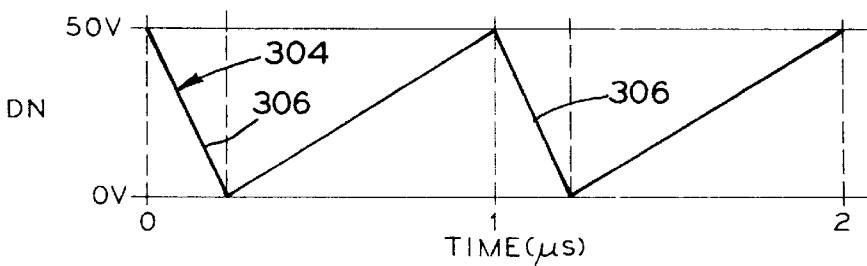

FIG. 8d

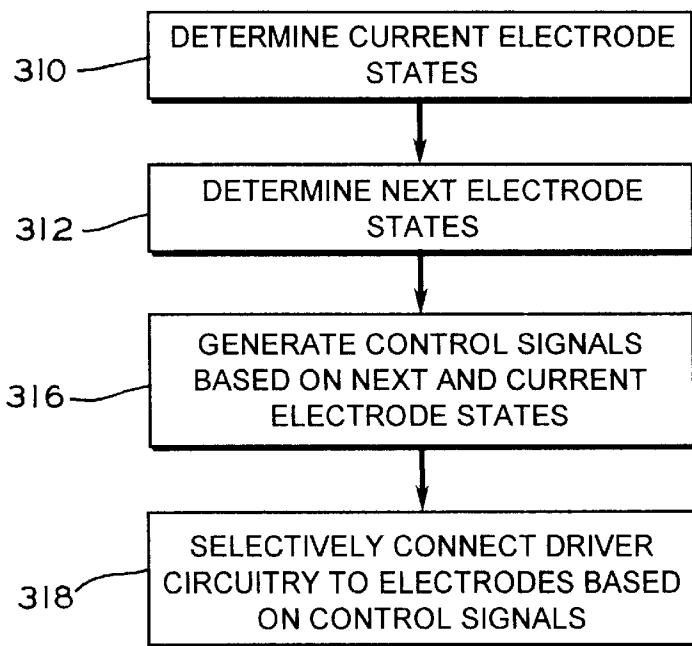

FIG. 9

## SYSTEM AND METHOD FOR DRIVING A FLAT PANEL DISPLAY AND ASSOCIATED DRIVER CIRCUIT

### TECHNICAL FIELD

The present invention relates to systems and methods for driving flat panel displays and associated driver circuits.

### BACKGROUND ART

Plasma display panels are currently expected to replace cathode ray tubes for many uses such as televisions, monitors, and other video displays. One important advantage of plasma display panels is that a relatively large display area can be provided with relatively minimal thickness as compared to cathode ray tubes.

The general construction of plasma display panels includes generally sheet-like front and back glass substrates having inner surfaces that oppose each other with a chemically stable gas hermetically sealed therebetween by a seal between the substrates at the periphery of the panel. Elongated electrodes covered by a dielectric layer are provided on both substrates with the electrodes on the front glass substrate extending transversely to the electrodes on the back glass substrate so as to thereby define gas discharge cells or pixels that can be selectively illuminated by an electrical driver of the plasma display panel. The panels can be provided with phosphors to enhance the luminescence and thus also the efficiency of the panels. The phosphors can also be arranged in pixels having several subpixels for respectively emitting the primary colors red, green, and blue to provide a full color plasma display panel.

In plasma display panels, it is becoming increasingly desirable to have larger display screens with more display lines and more intensity levels, with minimal power consumption. Known driving techniques for both color and monochrome alternating current plasma display panels include addressing periods in which charge quantities are retained by selected pixels, and sustain periods during which the charge quantities are excited to illuminate the selected pixels. During the sustain periods, the plasma display panel is driven by a bulk sustaining function which applies a uniform voltage waveform to the entire plasma display panel. The bulk sustained voltages are generated by an electrical circuit designed specifically for this purpose. During the addressing periods, individual row and column electrodes of the plasma display panel are selectively driven with voltages unique to the current image content of the plasma display panel. Selective address voltages are generated by driver integrated circuits which are specifically designed for direct connection to the plasma display panel electrodes.

As plasma display panels increase in size, number of display lines, and number of intensity levels, the power requirements of the driver circuits also increase. Energy recovery circuits are employed in plasma display panels to help reduce power consumption. Existing energy recovery circuits are used with bulk sustain electrode pairs in which two pulse generators provide sustained pulses with waveforms 180° out of phase to each other. For example, U.S. Pat. No. 5,654,728 issued to Kanazawa et al. discloses bulk driver energy recovery circuits.

A primary disadvantage associated with existing driving techniques is the fact that the column or data electrode driver circuits are responsible for a very significant amount of the overall plasma display panel power consumption. This is because the data electrode driver outputs pulse at a much higher frequency than the bulk sustain driver outputs.

## SUMMARY OF THE INVENTION

It is, therefore, an object of the present invention to provide a system and method for driving a flat panel display which utilizes energy efficient driving techniques for the data electrodes.

It is another object of the present invention to provide a display driver circuit for a flat panel display which is versatile enough to be used for a variety of applications, and capable of energy efficient data electrode driving in a plasma display panel.

In carrying out the above objects and other objects and features of the present invention, a system for driving a flat panel display having display pixels at cross-points of scan electrodes and data electrodes is provided. The system comprises a register capable of storing display bits, and a latch connected to the register and having outputs. Each register bit represents a next state for a corresponding electrode. Each latch output represents a current state for a corresponding electrode. The system further comprises logic circuits and driver circuitry. Each logic circuit corresponds to an electrode. Each logic circuit produces control signals based on the next state and the current state of the corresponding electrode. The driver circuitry includes a change up driver and a change down driver. Each electrode is selectively connectable to the driver circuitry by the corresponding logic circuit control signals.

Each logic circuit is configured such that upon an activation signal, the logic circuit control signals connect the change up driver to electrodes having a low current state and a high next state. Further, the logic circuit control signals connect the change down driver to electrodes having a high current state and a low next state.

In a preferred embodiment, each logic circuit further includes a first input connected to the corresponding register bit, and a second input connected to the corresponding latch output. A combinational logic network receives the first and second inputs, and generates the plurality of control signals. The plurality of control signals include a change up control signal for selectively connecting the change up driver to the corresponding electrode, and a change down control signal for selectively connecting the change down driver to the corresponding electrode. The combinational logic network is configured such that upon the activation signal, the change up control signal is asserted when the corresponding electrode has a low current state and a high next state. The change down control signal is asserted when the corresponding electrode has a high current state and a low next state.

Further, in a preferred embodiment, the plurality of control signals include a hold up control signal and a hold down control signal. The combinational logic network asserts the hold up control signal upon the actuation signal when the corresponding electrode has a high current state and a high next state. The combinational logic network asserts the hold down control signal upon the actuation signal when the corresponding electrode has a low current state and a low next state. The asserted hold up control signal connects the corresponding electrode to a hold up voltage source; the asserted hold down control signal connects the corresponding electrode to a hold down voltage source.

Further, in a preferred embodiment, the system further comprises a plurality of change up switch elements and a plurality of change down switch elements. Each change up switch element has an input connected to the change up control signal of a corresponding logic circuit, a first terminal connected to the change up driver, and a second terminal connected to the corresponding electrode. Each change

down switch element has an input connected to the change down control signal of the corresponding logic circuit, a first terminal connected to the change down driver, and a second terminal connected to the corresponding electrode.

Further, in carrying out the present invention, a display driver circuit for a flat panel display is provided. The driver circuit comprises a register, a latch, logic circuits corresponding to the electrodes, and change up and change down switch elements.

Further, in carrying out the present invention, a plasma display panel including a pair of substrates positioned to define a gap region therebetween is provided. Electrodes disposed in the gap region form display lines composed of pixels. The plasma display panel includes a driver system made in accordance with the present invention.

Still further, in carrying out the present invention, a method of driving a flat panel display is provided. The method comprises determining a current state for each electrode, determining a next state for each electrode, generating a plurality of control signals for each electrode based on the next state and the current state for that electrode, and selectively connecting driver circuitry to each electrode based on the control signals for that electrode.

The advantages accruing to the present invention are numerous. For example, the present invention provides a system and method for driving a flat panel display and an associated driver circuit which is versatile enough to be used for a variety of electrode groups, and capable of energy efficient electrode driving.

The above objects and other objects, features, and advantages of the present invention will be readily appreciated by one of ordinary skill in the art from the following detailed description of the best mode for carrying out the invention when taken in connection with the accompanying drawings.

#### BRIEF DESCRIPTION OF THE DRAWINGS

FIG. 1 is an exploded perspective view that is somewhat schematic to illustrate the active area of a plasma display panel constructed in accordance with the present invention;

FIG. 2 is a partially broken away sectional view taken through the plasma display panel of FIG. 1 to illustrate its construction;

FIG. 3 is a system for driving a plasma display panel, shown as a display driver integrated circuit chip connected to driver circuitry in a first embodiment of the present invention;

FIG. 4a is a graph depicting voltage waveforms for data electrodes in the first embodiment of the present invention;

FIG. 4b is a graph depicting a voltage waveform for the latch in the first embodiment of the present invention;

FIG. 4c is a graph depicting a voltage waveform for the change up inductor in the first embodiment of the present invention;

FIG. 4d is a graph depicting a voltage waveform for the change down inductor in the first embodiment of the present invention;

FIG. 5 illustrates driver circuitry similar to that of the system shown in FIG. 3, with a voltage source positioned between the change up and change down inductors to compensate for any losses;

FIG. 6 illustrates driver circuitry in a second embodiment of the present invention;

FIG. 7a is a graph depicting voltage waveforms data electrodes in the second embodiment of the present invention;

FIG. 7b is a graph depicting a voltage waveform for the latch in the second embodiment of the present invention;

FIG. 7c is a graph depicting the change up voltage waveform in the second embodiment of the present invention;

FIG. 7d is a graph depicting a voltage waveform for controlling a first pair of switches to drive the oscillator shown in FIG. 6;

FIG. 7e is a graph depicting a voltage waveform for controlling a second pair of switches to drive the oscillator shown in FIG. 6;

FIG. 7f is a graph depicting the change down voltage waveform in the second embodiment of the present invention;

FIG. 8a is a graph depicting voltage waveforms for data electrodes in a third embodiment of the present invention;

FIG. 8b is a graph depicting a voltage waveform for the latch in the third embodiment of the present invention;

FIG. 8c is a graph depicting the change up voltage waveform in the third embodiment of the present invention;

FIG. 8d is a graph depicting the change down voltage waveform in the third embodiment of the present invention; and

FIG. 9 is a block diagram illustrating a method of the present invention for driving a flat panel display, such as the plasma display panel shown in FIGS. 1 and 2.

#### BEST MODE FOR CARRYING OUT THE INVENTION

With reference to the somewhat schematic view of FIG. 1 of the drawings, an alternating current plasma display panel constructed in accordance with the invention is generally indicated at 20. The plasma display panel 20 includes a generally sheet-like front glass substrate 22 and a generally sheet-like back glass substrate 24. The front glass substrate 22 has an outer surface 26 that faces forwardly during use toward the viewer of the display. The front glass substrate 22 also includes an inner surface 28 that faces rearwardly during use and includes elongated electrodes 30 over its extent with only several of these being illustrated by schematic hidden line representation. These electrodes 30, as illustrated in FIG. 2, are covered by a dielectric layer 32. The electrodes 30 extend in a spaced and parallel relationship to each other in a first direction generally between opposite extremities of the display panel 20 where suitable electrical connections are made to an electrical driver which will be described. Although the front and back glass substrates 22 and 24 for ease of illustration are shown somewhat block shaped, they actually have sheet-like shapes with relatively large dimensions between their opposite extremities and relatively thin thicknesses.

With continuing reference to FIG. 1 and additional reference to FIG. 2, the back glass substrate 24 of the plasma display panel 20 includes an outer surface 34 that faces rearwardly during use of the panel away from the observer and also includes an inner surface 36 that faces forwardly in an opposed relationship to the inner surface 28 of the front glass substrate 22. This inner surface 36 of the back glass substrate 24, as illustrated in FIG. 2, includes gas discharge troughs 38 and also includes barrier ribs 40 that space the gas discharge troughs from each other.

These gas discharge troughs 38 and barrier ribs 40 are elongated, as schematically illustrated in FIG. 1, extending in a spaced and parallel relationship to each other in a second direction that is transverse to the first direction of the

electrodes **30** of the front glass substrate **22**. The back glass substrate **24** includes elongated electrodes **42** within the gas discharge troughs **38** and each of these electrodes is covered by a dielectric layer **44** that may be covered with an unshown thin layer of magnesium oxide or other suitable secondary emissive thin film that lowers the required operating voltages. The electrodes **42** of the back glass substrate extend to at least one extremity of the display panel **20** for connection with an electrical driver of the panel. Gas discharge cells or pixels **46** are provided at cross-points of the front electrodes **30** and back electrodes **42**. A chemically stable gas is hermetically sealed by a seal between the peripheries of the front and back glass substrates **22** and **24**. For color displays, an addition of Helium, Neon, or Argon to Xenon has been found to lower the breakdown voltage.

As illustrated in FIG. 2, the gas discharge troughs **38** may also have phosphors **48** that enhance the luminescence and also can be arranged in pixels having adjacent gas discharge troughs providing subpixels for emitting the three primary colors red, green, and blue to provide a full color display. In the latter case, the pitch of the spacing between the gas discharge troughs **38** should be approximately one-third of the pitch between the electrodes **30** of the front glass substrate to have the same pixel resolution in both directions of the panel. Note that the phosphor may be used as some or all of the dielectric layer, in which case the previously mentioned secondary emissive thin film may be applied over the phosphor.

With continuing reference to FIG. 2, it will be noted that the thickness of the front and back glass substrates **22** and **24** is broken away because the depth of the gas discharge troughs **38** and the corresponding height of the barrier ribs **40** is only on the order of magnitude of thousandths of an inch as compared to the much thicker substrates. For example, in one desired construction, the spacing pitch between the gas discharge troughs is four thousandths of an inch with each trough having a width of three thousandths of an inch, each barrier rib **40** having a width of one thousandth of an inch and a height of four thousandths of an inch. These exemplary dimensions are not intended to limit the invention, but rather to provide a general understanding of the relatively small dimensions involved. Also, it should be noted that the dielectric layer **44** and phosphors **48** are also very thin, e.g. a number of microns thick, but are shown thicker for ease of illustration.

Various other features and techniques which may be utilized with plasma display panel **20** are described in detail in copending U.S. patent application Ser. No. 08/933,905, filed on Sep. 23, 1997, naming James C. Rutherford as inventor, and entitled "System and Method for Driving a Plasma Display Panel", which is hereby incorporated by reference in its entirety.

In column discharge type plasma display panels, the column electrodes typically serve as the data electrodes and the row electrodes typically serve as the scan electrodes. During sustaining, accumulated wall charges are oscillated between the row and column electrodes to illuminate the display. In surface discharge type plasma display panels, the column electrodes typically serve as the data electrodes. There are typically two sets of row electrodes. The row scan electrodes are used for addressing. During sustaining, accumulated wall charges are oscillated between the row scan electrodes and corresponding row maintenance electrodes paired with the row scan electrodes as is well known in the art.

Embodiments of the present invention are not limited specifically to column electrodes. Plasma display driving

techniques may attempt to use row or column electrodes in such a manner that a register controls the electrode states. Although one aspect of the present invention is its applicability to column electrodes, it may become desirable to employ embodiments of the present invention for scan, maintenance and/or data electrode drivers on the same display apparatus. However, to best illustrate the advantages of embodiments of the present invention, the following description is directed particular toward column data electrode driver circuits, which are also commonly referred to as data electrode driver circuits or addressing electrode driver circuits.

Column driver integrated circuit power consumption is largely displacement power which is a function of address voltage, electrode capacitance, and addressing frequency. Displacement power arises from repeatedly charging and discharging the capacitance of the column electrode through a resistive element, such as a transistor. Embodiments of the present invention reduce displacement power significantly, and in some instances, may allow reduction or elimination of expensive heat sinks for the driver chips.

With reference to FIG. 3, a system **58** for efficiently driving a flat panel display such as plasma display panel **20**, is shown. The system **58** includes integrated circuit chip **60** for efficiently driving the column electrodes. Integrated circuit chip **60** is specifically designed for direct connection to the plasma display panel electrodes, typically in groups of **64** electrodes. Each electrode is driven by an associated column driver circuit of integrated circuit chip **60**. As illustrated, a first column driver circuit **62** corresponds to electrode **80**. A second column driver circuit **64** corresponds to electrode **82**. Chip **60** includes a plurality of pins for connection to other plasma display panel circuitry. Pin **66** connects to a hold up voltage source of  $V_{pp}$ . Pin **68** connects to a hold down voltage source or ground, designated as GND. Pin **70** connects to the up driver circuitry, and is designated UP. Pin **72** connects to the down driver circuitry, and is designated DN. Pin **74** and pin **76** connects to the LATCH signal and clock signal, respectively. Pin **78** receives the display data signals.

The driver circuit on chip **60** includes a register capable of storing display bits. The register is preferably a shift register capable of parallel output, and is formed by a plurality of cascaded D flip-flops **84**. Each bit **86** represents a next state for a corresponding data electrode. A latch is connected to the register and is preferably formed of a plurality of D flip-flops **88** with a D flip-flop input connected to each register output bit **86**. Latch outputs **90** represent a current state for corresponding data electrodes. It is to be appreciated that the latch is sometimes referred to as a holding register by those skilled in the art of display panels, and that the term latch as used herein is intended to encompass such holding registers. Further, the terms register and latch as used herein are intended to encompass other bistable device arrangements capable of performing as a register or as a latch.

A logic circuit **96** is preferably a combinational logic network made up of a plurality of gates **98**. Logic circuit **96** has a first input connected to register bit **86**, and a second input connected to corresponding latch output **90**.

It is to be understood that all of the column driver circuits are substantially identical, and like reference numerals have been used to indicate like components among the column circuit drivers. To facilitate an understanding of the present invention, only column driver circuit **62** will be described.

Logic circuit **96** generates a plurality of control signals. A hold up control signal **100**, a change up control signal **102**,

a change down control signal **104**, and a hold down control signal **106**, are each determined by logic circuit **96**. As shown, the D flip-flops **88** forming the latch are triggered by the falling edge of the LATCH signal, as indicated by the dynamic indicator and the polarity indicator. Logic circuit **96** is a gated logic circuit, and is only active when LATCH is high. The rising edge of the LATCH signal is the beginning of the activation signal, and the falling edge of LATCH is the end of the activation signal which causes the state transition to occur.

As shown, logic circuit control signals **100**, **102**, **104**, **106** operate in one hot code. While LATCH is low, either the hold up control signal **100** or the hold down control signal **106** is asserted. If the current state is high while LATCH is low, the hold up control signal **100** is asserted. If the current state is low, while LATCH is low, the hold down control signal **106** is asserted. When the LATCH signal is high, and the current and next states for the corresponding electrodes are both low, the hold down control signal **106** is asserted. When the current and next state are both high, and LATCH is high, the hold up control signal **100** is asserted. When LATCH is high, and the current and next state for the corresponding electrode are different, either the change up control signal **102** or the change down control signal **104** is asserted. When LATCH is high, the current state is low, and the next state is high, the change up control signal **102** is asserted. When LATCH is high, the current state is high, and the next state is low, the change down control signal **104** is asserted. It is to be appreciated that various alternative designs for logic circuit **96** may be made in accordance with the present invention.

For example, alternative to one hot code, the logic circuit **96** may be configured such that after the activation signal (when the activation signal is low), the hold up control signal **100** and the change up control signal **102** are asserted to connect the hold up voltage source and the change up driver to electrodes having a high current state. Further, the hold down control signal **106** and the change down control signal **104** are asserted to connect the hold down voltage source and the change down driver to electrodes having a low current state.

The arrangement described immediately above is very advantageous when non-zero current is anticipated for any inductors in the driver circuitry when LATCH is pulled low, particularly in the driver circuitry of FIG. **3** or **5**. Such an arrangement may be easily implemented, for example, with two additional OR type gates at the change up and down control signals of logic circuit **96**.

The logic circuit asserts the control signals to selectively connect the hold up driver, hold down driver, change up driver, or change down driver to each electrode corresponding to each respective logic circuit **96**. In the embodiment shown in FIG. **3**, driver circuitry **110** includes a change up driver formed by first inductor **112**, and a change down driver formed by second inductor **114**. The first and second inductors **112** and **114**, respectively, are connected to power source **116** for drawing current when necessary.

Hold up control signal **100** and hold down control signal **106** are connected to hold up switch **120** and hold down switch **122**, respectively. Change up control signal **102** and change down control signal **104** are connected to change up switch **124** and change down switch **126**, respectively. The switches may be implemented in any of a variety of ways known in the art, such as MOSFETs. Further, all switches need not be implemented in the same manner. For example, a first type of switch device may be employed for the hold

drivers, and a second type of switch for the change drivers. The logic circuit control signals **100**, **102**, **104**, **106** are connected to the switch inputs. Hold up switch **120** has a terminal connected to  $V_{pp}$  source pin **66**, and another terminal connected to data electrode **80**. Hold down switch **122** has a terminal connected to ground pin **68**, and another terminal connected to data electrode **80**. Change up switch **124** has a terminal connected to data electrode **80**, and another terminal connected to the cathode of diode **130**. The anode of diode **130** is connected to up driver pin **70**. Diode **130** prevents current from leaking into the change up driver, and from leaking into other outputs. Another diode **132** has an anode connected to ground pin **68** and a cathode connected to up driver pin **70** to prevent up driver pin **70** from becoming excessively low in voltage; still another diode may be connected so as to prevent up driver pin **70** from becoming excessively high in voltage. Change down driver switch **126** has a terminal connected to data electrode **80**, and another terminal connected to the anode of diode **134**. The cathode of diode **134** is connected to down driver pin **72**. Diode **134** prevents current from leaking from the change down driver, and from leaking into other outputs. Another diode **136** has a cathode connected to  $V_{pp}$  source pin **66** and an anode connected to down driver pin **72** to prevent down driver pin **72** from becoming excessively high in voltage; still another diode may be connected so as to prevent down driver pin **72** from becoming excessively low in voltage.

During use of chip **60** in a plasma display panel, data at data pin **78** is clocked into the shift register consisting of D flip-flops **84**. Clock pin **76** is oscillated to enter the display data into the register, while LATCH is held low. LATCH is then pulled from low to high to activate logic circuit **96**, allowing logic circuit **96** to generate any one of the following outputs based on the current and next states: "hold up", "hold down", "change up", or "change down". The appropriate control signal of logic circuit **96** is then asserted, until LATCH is pulled low again to restrict the output of logic circuit **96** to either "hold up" or "hold down". As will be further described in the description of circuit voltage waveforms, the pulse width of the LATCH pulse is preferably coordinated with the electrode capacitance, number of electrodes in the group driven by chip **60**, and the parameters of the driver circuit such as driver circuit inductance in the inductor embodiment shown in FIG. **3**.

With reference to FIGS. **4a-4d**, voltage waveforms for a first embodiment of the change up and change down driver circuitry which uses first and second inductors **112** and **114** (FIG. **3**) respectively, are shown. The data electrode driving waveform is shown in FIG. **4a** and is indicated at **140**. The LATCH driving waveform is shown in FIG. **4b** and is indicated at **142**. The up recover waveform as measured at up driver pin **70** (FIG. **3**) is best shown in FIG. **4c** and indicated at **144**. The down recover waveform as measured at down driver pin **72** (FIG. **3**) is best shown in FIG. **4d** and indicated at **146**.

To facilitate an understanding of the first embodiment of the change up and change down driver circuitry, the graphs depicted in FIGS. **4a-4d** all have a common temporal scale with dashed lines marking the boundaries of charging and discharging intervals. With reference to FIGS. **3** and **4a-4d**, at 0 nanoseconds, LATCH is pulled high to activate gated logic circuit **96**, at pulse **152** (FIG. **4b**). Because the electrode current state is low or logic '0' and the next state is high or logic '1' for all electrodes, change up control signal **102** is asserted for all electrodes. Switch **124** is then activated by the voltage at its input from change up control

signal **102**. Up driver pin **70** is immediately pulled down to 0 volts, as best shown in FIG. **4c**. The current in inductor **112** increases as up driver pin **70** rises toward 25 volts. When up driver pin **70** reaches 25 volts, the current through inductor **112** will be at its maximum. The current through inductor **112** then decreases as the voltage at up driver pin **70** approaches 50 volts. When up driver pin **70** reaches 50 volts, LATCH is pulled low, turning off switch **124**, and the charging of electrode **80** and the other electrodes is complete. The charging of electrode **80** and the others is best shown in FIG. **4a** at wave portion **150**. The voltage of up driver pin **70** is best shown at wave portion **154** in FIG. **4c**. It is to be appreciated that while charging electrode **80**, the voltage drop across closed switch **124** is substantially minimized to reduce driver chip power consumption. In the embodiment illustrated, the LATCH pulse is about 250 nanoseconds, and each address voltage pulse is about 1 microsecond.

As depicted in FIGS. **4a-4d**, the voltage waveforms between 0 nanoseconds and 250 nanoseconds represent the simultaneous charging of all data electrodes in the electrode group driven by driver chip **60**. The inductance value for inductor **112** is selected based on the number of electrodes in the group, electrode capacitance, and the desired charging time for the entire group of electrodes when all of the electrodes in the group are to be charged.

The LATCH signal ideally has a pulse width equal to the time required to simultaneously charge all electrodes of the group, as best shown in the 0 to 250 nanosecond interval in FIGS. **4a-4d**.

In the interval from 1000 nanoseconds to 1250 nanoseconds, the simultaneous discharging of all electrodes of the group driven by driver chip **60** is depicted. Data electrode **80**, and all other data electrodes discharge at wave portion **156** of waveform **140** in FIG. **4a**. LATCH pulse **158** (FIG. **4b**) causes the down driver pin **72** to behave as shown at portion **160** of waveform **146** in FIG. **4d**. The discharging occurring in the interval from 1000 nanoseconds to 1250 nanoseconds is similar to the charging of the electrode group in the interval from 0 to 250 nanoseconds. When discharging, LATCH pulse **158** activates gated logic circuit **96** which asserts change down control signal **104** to turn on switch **126** for all electrodes. Inductor **114** preferably has the same inductance value as inductor **112**; however, a different inductance value may be chosen for inductor **114** if, for example, the discharging time desired for all electrodes of the group is different than the charging time desired for all electrodes of the group.

With continuing reference to FIGS. **3** and **4a-4d**, the substantially simultaneous charging of some electrodes and discharging of other electrodes, all of which are in the group of electrodes controlled by driver circuit chip **60**, is illustrated. In the time interval from 2000 nanoseconds to 2250 nanoseconds, the substantially simultaneous charging and discharging is depicted. Data electrode wave portion **170** of waveform **140**, shown in FIG. **4a**, shows the charging of some of the electrodes of the electrode group upon LATCH pulse **172** (FIG. **4b**). Up driver pin **70** behaves as shown at wave portion **174** of waveform **144** shown in FIG. **4c**. Because only some of the electrodes are being charged, the capacitive load at the output of change up switch **124** is less than the maximum load. Hence, the resonant frequency at up driver pin **70** is higher, and as illustrated, the charging time for the electrodes is shorter. As shown in FIG. **4a**, the data electrodes are fully charged before the end of LATCH pulse **172**. Wave portion **180** of data electrode waveform **140** illustrates partial discharging of the electrodes while change

up switch **124** remains on. Diode **130** limits the leakage currents to minimize lost charge. After LATCH pulse **172**, hold up driver control signal **100** is asserted, turning on hold up switch **120**. Wave portion **182** of waveform **140** in FIG. **4a** depicts the completion of electrode charging, which occurs through hold up switch **120**.

Other electrodes in the electrode group driven by driver chip **60** are discharged. The charging and discharging of different electrodes in the same electrode group is preferably performed substantially simultaneously. Preferably, both charging and discharging are simultaneously initiated upon the rising edge of the LATCH pulse. However, delay may be added to the starting of either charging or discharging, as desired.

The other electrodes of the group, which are being discharged, have voltage waveforms **186** illustrated in FIG. **4a**. Wave portion **188** shows the voltage on the discharge electrodes. Wave portion **190** of waveform **146** (FIG. **4d**) for down driver pin **72**, illustrates electrode discharging through the inductor. Data electrode voltage waveform **186**, after descending to 0 volts, before the end of LATCH pulse **172**, undergoes slight charging at wave portion **192** due to leakage current through diode **134**. As shown in wave portion **194** of waveform **186** (FIG. **4a**), the hold down driver quickly pulls the discharged electrodes to zero volts upon the end of the latch pulse **172**.

Another discharge of several electrodes of the group of electrodes driven by driver chip **60** occurs at 3000 nanoseconds. This discharge occurs in the same manner as those previously described. It is to be appreciated that the substantially simultaneous charging and discharging of electrodes in the same group induces current in both first inductor **112** and second inductor **114**. The discharge current through inductor **114** may then be drawn through inductor **112** to charge any electrodes being charged. By efficiently routing current through the pair of inductors, current draw from source **116** is substantially minimized, and the average current draw from source **116** is zero. Alternatively, source **116** may be a large capacitor.

Embodiments of the present invention are advantageous because the voltage drop across the change up and change down switches is substantially reduced with techniques so efficient that the techniques may be employed in panel addressing. The voltage reduction across the change up and change down switches causes the chip **60** to dissipate less energy; hence, chip operation is cooler. Further, embodiments of the present invention are advantageous because current draw from the power source for charging and discharging may be minimized, if desired.

Alternatively, inductors **112** and **114** may be configured such that the inductance of each is variable to match the loading conditions. For example, each driver may comprise a series of inductors, with the individual inductors configured in the circuit so that individual inductors may be switched out of the circuit to vary inductance. Such a circuit would allow the inductances of the up driver circuitry and the down driver circuitry to be individually, dynamically, matched to the capacitive load, as desired. As a result, the change up and change down times could be made to always match a given LATCH pulse width.

The potential for reducing power dissipation within chip **60** is so significant that, compared to the same integrated circuit silicon area used in prior driver chips, the driver schemes of the present invention are expected to require much less area for output function devices (for the same number of outputs). This allows considerably more area for

input and/or additional output function silicon. Therefore, more functionality may be added to each integrated circuit chip, because the power efficiency allows more functionality to be achieved in the same chip area. For this reason, embodiments of the present invention are significantly applicable to plasma display panel column drivers as well as row drivers, and both row and column drivers for electroluminescent displays, liquid crystal displays, and field emissive displays.

With reference to FIG. 5, a preferred implementation of the first embodiment of the present invention is generally indicated at **200**. Driver circuitry **200** includes a  $V_{pp}$  connection **202** for connecting to a high voltage source, an up driver connection **204** for connecting to up driver pin **70**, a down driver connection **206** for connecting to down driver pin **72**, and a ground connection **208** for connecting to a low voltage source or ground. First and second inductors **210** and **212**, respectively, limit the voltage drop across change up switch **124** and change down switch **126**. A pair of main voltage sources **214** and **216** are, for example, each about 22.5 volts. A supplemental voltage source **216** is, for example, about 5 volts. Supplemental voltage source **216** provides a voltage difference between inductors **210** and **212** to compensate for any losses including diode drops.

With reference to FIG. 6, a second embodiment of driver circuitry is generally indicated at **230**. An oscillator circuit is formed by ferromagnetic core inductor **232** and capacitor **234**. Up driver connection **236** is connected to one side of the oscillator, while down driver connection **238** is connected to the other side of the oscillator. The circuit **230** also has a  $V_{pp}$  connection **240** for connecting to a high voltage source, and a ground connection **242** for connecting to a low voltage source or ground. A first switch **244** and a second switch **246** may be simultaneously asserted when the oscillator circuit is at an appropriate peak voltage to supply additional energy to the oscillator circuit which compensates for any resistive losses. Further, a third switch **248** and a fourth switch **250** may be simultaneously asserted when the oscillator is at its opposite peak to compensate for any resistive losses.

With reference to FIGS. 7a-7f, voltage waveforms for the oscillator type driver circuitry embodiment (FIG. 6) are shown. The electrode waveforms are shown in FIG. 7a. Waveform **270** illustrates some of the electrodes, while waveform **272** illustrates others of the electrodes. The LATCH waveform is shown in FIG. 7b, and is indicated at **274**. The waveform for up driver connection **236** is shown in FIG. 7c, and is indicated at **276**. The waveform for down driver connection **238** is shown in FIG. 7f, and is indicated at **282**. First and second switches **244** and **246** are driven with the waveform shown in FIG. 7d, indicated at **278**. Third and fourth switches **248** and **250** are driven with the waveform shown in FIG. 7e, indicated at **280**.

It is to be appreciated that the free running oscillator circuit, when synchronized correctly with the LATCH signal, reduces the voltage drop across the change up and change down switches. This results in a driver chip with minimal power dissipation in the change up and change down switches.

As best shown in FIG. 6, a center tap **256** is separated from  $V_{pp}$  connection **240** by a capacitor **252**, and from GND connection **242** by a capacitor **254**. Centertap **256** stabilizes the oscillator.

It is to be appreciated that a variety of driver circuits may be employed to reduce the voltage drop across the change up and change down switches, thereby reducing chip power

consumption, based on the display data in the shift register (next state) and at the latch output or holding register (current state). Further, embodiments of the present invention may be employed to reduce total display power consumption. The inductor embodiments shown in FIGS. 3 and 5, and the oscillator embodiment shown in FIG. 6, are merely illustrative configurations of the present invention which controls electrode connection to voltage driver circuits based on next and current electrode states.

With reference to FIGS. 8a-8d, alternative waveforms for the electrodes, latch, change up connection, and change down connection are shown. The data electrode resulting voltage waveforms are indicated at **290** and **292**. Waves **290** and **292** have opposite phases to illustrate simultaneous charging and discharging which is preferred, but not required. Simultaneous or substantially simultaneous charging and discharging facilitates  $V_{pp}$  source current draw minimizing in addition to efficient electrode driving within the driver chip. Simultaneous charging and discharging is preferred to maximize the data valid time for the data electrodes.

Electrode waveforms **290** and **292** have charging portions **294**, and discharging portions **296**. Latch waveform **298** is shown in FIG. 8b, and has a pulse width which corresponds to the charging and discharging times for the electrodes. The change up driver waveform **300**, in FIG. 8c, has charging portions **302** which correspond to charging portions **294** of the electrode waveforms in FIG. 8a. The change down driver waveform **304**, in FIG. 8d, has discharging portions **306** which correspond to discharging portions **296** of the electrode waveforms in FIG. 8a. It is to be appreciated that the ramp change up and ramp change down driver waveforms shown in FIGS. 8c-8d provide the maximum power dissipation reduction in the resistive switching components, due to the second-order nature of power dissipated. The waveforms shown in FIGS. 8a-8d may be generated by a number of common function generator circuits known to those of ordinary skill in the art.

With reference to FIG. 9, a method of the present invention for driving a flat panel display will now be described. Methods of the present invention are particularly well suited for data electrode driving; however, embodiments of the present invention may be employed in scanning or sustaining electrodes, if desired, where appropriate. At block **310**, the current states are determined for all electrodes in a group of electrodes, such as a group of electrodes all driven by a single driver chip. At block **312**, the next states are determined for all electrodes of the electrode group. At block **316**, control signals are generated based on the current and next state of each electrode. The control signals may indicate any of the following conditions: "hold up", "hold down", "change up", "change down", of which "hold up" and "change up", or "hold down" and "change down" may be asserted simultaneously as described previously. Other conditions for driving the electrodes may be indicated by the control signals, such as "float" or "no driver", if desired for the particular configuration. At block **318**, each electrode of the group is selectively connected to the appropriate driver circuitry based on the control signals, and preferably the activation signal.

Further, other functions and/or structures may be implemented on the chip such as polarity and on-chip memory due to the cooler chip operation resulting from the present invention. Designs of the present invention may allow memory arrays and interface logic to be incorporated as front end functions of the driver chips. Still further, it is to be appreciated that embodiments of the present invention

may be implemented on dielectric isolated wafers, such as silicon on insulator (SOI) technologies.

While the best mode for carrying out the invention has been described in detail, those familiar with the art to which this invention relates will recognize various alternative designs and embodiments for practicing the invention as defined by the following claims.

What is claimed is:

1. A plasma display panel including a pair of substrates positioned to define a gap region therebetween, and electrodes disposed in the gap region to form display lines composed of pixels, the electrodes including a group of electrodes, the plasma display panel further comprising:

a register capable of storing display bits, each bit representing a next state for a corresponding electrode;

latch connected to the register and having outputs, each output representing a current state for a corresponding electrode;

logic circuits corresponding to the electrodes, each logic circuit generating a plurality of control signals based on the next state and the current state of the corresponding electrode, the plurality of control signals including a change up control signal, a change down control signal, a hold up control signal, and a hold down control signal; and

driver circuitry including a change up driver, a change down driver, a hold up voltage source, and a hold down voltage source, each electrode being selectively connectable to the driver circuitry by the corresponding logic circuit control signals,

wherein each logic circuit is configured such that upon an activation signal, the logic circuit asserts the change up control signal to connect the change up driver to electrodes having a low current state and a high next state, asserts the change down control signal to connect the change down driver to electrodes having a high current state and a low next state, asserts the hold up control signal to connect the hold up voltage source to electrodes having a high current state and a high next state, and asserts the hold down control signal to connect the hold down voltage source to electrodes having a low current state and a low next state.

2. The plasma display panel of claim 1 wherein the logic circuit is configured such that after the activation signal, the hold up control signal and the change up control signal are asserted to connect the hold up voltage source and the change up driver to electrodes having a high current state,

and the hold down control signal and the change down control signal are asserted to connect the hold down voltage source and the change down driver to electrodes having a low current state.

3. A method of driving a flat panel display, the flat panel display including a group of electrodes, the method comprising:

determining a current state for each electrode of the group of electrodes;

determining a next state for each electrode of the group of electrodes;

generating at least one control signal for each electrode based on the next state and the current state for that electrode; and

selectively connecting driver circuitry to each electrode based on the at least one control signal for that electrode, such that electrodes having a low current state and a high next state are connected to a change up driver and electrodes having a high current state and a low next state are connected to a change down driver.

4. A system for driving a flat panel display having a predetermined number of scan electrodes and a predetermined number of data electrodes, the system comprising:

driver circuitry including a change-up driver, a change-down driver, and an oscillator, wherein the oscillator provides a first voltage waveform corresponding to the change-up driver and a second voltage waveform corresponding to the change-down driver; and

logic circuits generating control signals for selectively connecting each data electrode to the driver circuitry based on the next state and the current state of the data electrode, wherein the logic circuits are configured such that upon an activation signal, the logic circuit control signals connect the change up driver to data electrodes having a low current state and a high next state and the change down driver to data electrodes having a high current state and a low next state.

5. The system for driving a flat panel display defined in claim 4 wherein the first and second voltage waveforms have opposite phases.

6. The system for driving a flat panel display defined in claim 4 wherein the driver circuitry provides a change-up driver, a change down driver, a hold-up driver and a hold-down driver.

\* \* \* \* \*