

J. F. JOHNSON.  
Hemmers for Sewing-Machines.

No. 143,160.

Patented September 23, 1873.

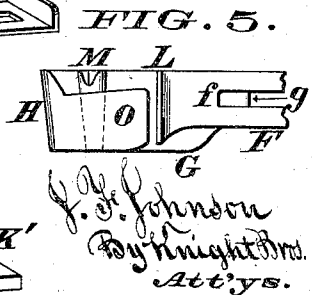
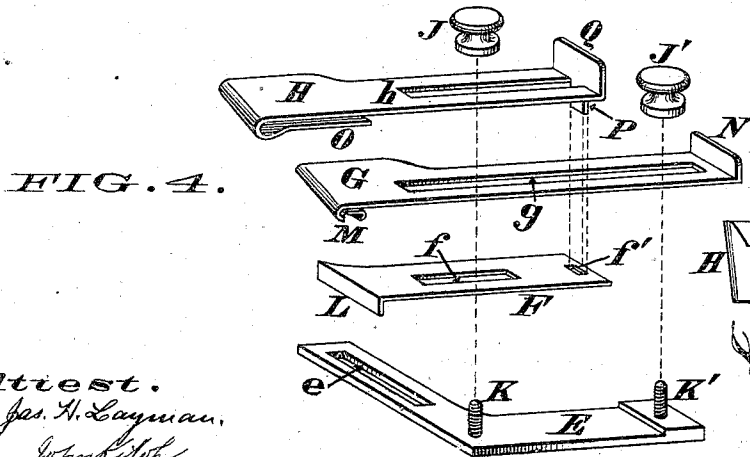
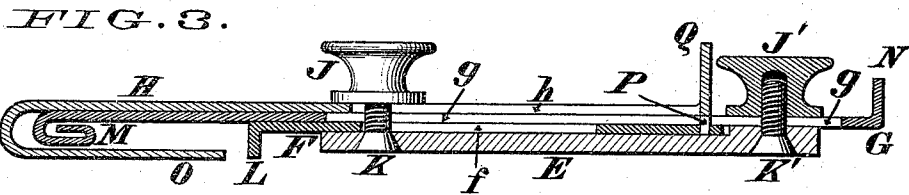
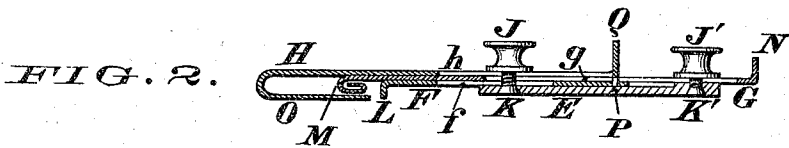
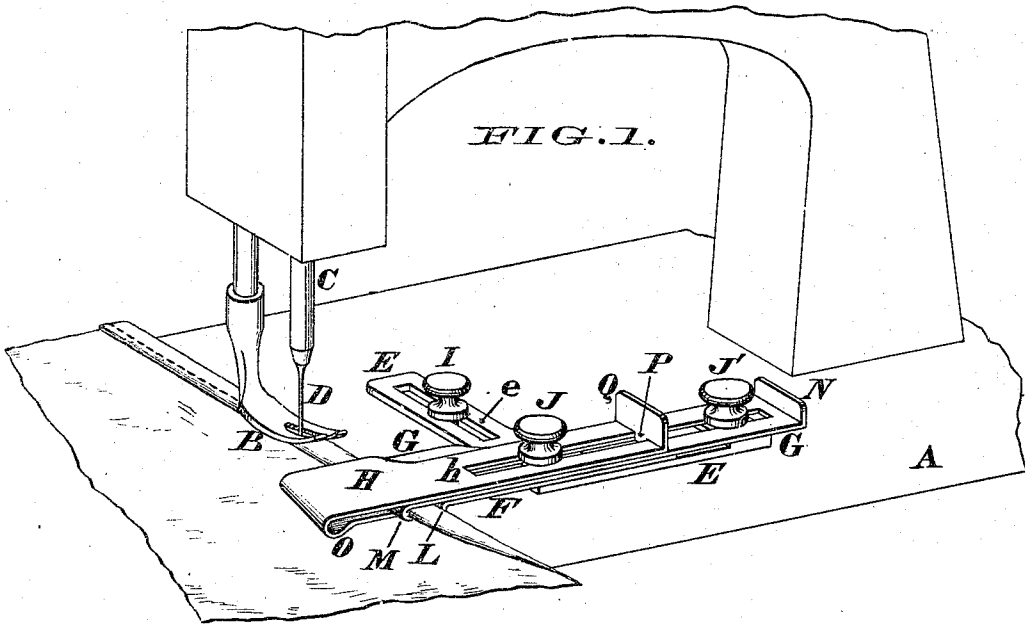

Attest.  
*Jas. H. Layman,*  
*John H. Layman,*

*J. F. Johnson*  
*By Knight & Co.*  
Att'ys.

# UNITED STATES PATENT OFFICE.

JOHN F. JOHNSON, OF CINCINNATI, OHIO.

## IMPROVEMENT IN HEMMERS FOR SEWING-MACHINES.

Specification forming part of Letters Patent No. 143,160, dated September 23, 1873; application filed August 23, 1873.

*To all whom it may concern:*

Be it known that I, JOHN F. JOHNSON, of Cincinnati, Hamilton county, Ohio, have invented a new and useful Hemming Attachment for Sewing-Machines, of which the following is a specification:

This is an improved form of those hemmers that are adapted to be attached to the cloth-plate of a sewing-machine; and comprises devices for forward or backward and right or left adjustment to suit the machine and the kind of work to be performed, and a provision of hemming-scroll, adjustable both for width and distance, and of simultaneously-adjustable gage and presser plate to correspond therewith.

Figure 1 is a perspective view, representing a hemmer embodying my improvements in position upon a sewing-machine. Fig. 2 is a vertical section of the same at right angles with the feed, the parts being set for a narrow hem. Fig. 3 is a similar section of the operative parts to a larger scale, said parts being set for a wider hem. Fig. 4 represents the parts of my hemmer detached. Fig. 5 is an under-side view of my scroll and spreader blade.

A, B, C, and D represent, respectively, the cloth-plate, presser-foot, needle bar, and needle of a sewing-machine.

My hemmer is composed of four plates, E, F, G, and H, a customary thumb-screw, I, and two nuts, J J'. My attachment plate or bracket E is of the represented L form, one limb having a slot, *e*, and the other limb having projecting vertically from it two screws, K K', which enter the nuts J J', whose office is to fasten the several members of the hemmer to their adjusted positions. The slot *e* is traversed by the customary thumb-screw I, by which the hemmer is attached to the cloth-plate, the said slot *e* enabling the hemmer to be set forward or backward, to suit the machine and the work to be performed; slots *f*, *g*, and *h* in the plates F, G, and H serving the same purpose in the complementary direction, or to right and left. Resting upon the bracket E is my gage-plate F, slotted at *f* to embrace the screw K, and at *f'* to receive a tongue, P, from spreader-plate H, thus compelling both these plates to move in conjunction, and to always maintain the same relative position and their proper parallelism with the other members, while permitting of their concurrent adjustment to right or left. The operative or

left end of gage-plate has a down-turned lip, L. Resting upon the said gage-plate is my scroll-plate G, whose left or outer end terminates in the customary flattened tapering scroll or volute M, and whose rear or right extremity takes the form of an upturned lip, N. The plate G is slotted at *g* for the screw K and tongue P, which operate to hold the said plate in line while being adjusted to the right or left. The whole is surmounted by spreader-plate H, whose slot *h* permits the traverse of screw K, and whose tongue P traverses the slot *g* of scroll-plate G, and occupies the slot *f'* of gage-plate F, as hereinbefore stated. The tongue P may be permanently secured by screw or rivet to the plate F, if desired. The outer or left end of plate H has a turned-under reflexed lip or blade, O, which acts as an elastic spreader for the cloth, and, in connection with the scroll and the gage, already described, serves to support the cloth, and also to hold the hem to its proper width and presentation for the stitching action. The right extremity of spreader-plate H is upturned, to form a handle, Q.

The members E, F, G, and H being held loosely together by nuts J and J', the hemmer is attached to the cloth-plate loosely by means of the screw I, and, being adjusted to its proper position in the line of feed, is permanently secured thereto by tightening the said screw. The scroll-plate G is now set at the proper lateral adjustment with respect to the needle, and is secured thereto by nut J'; and, finally, the gage-plate, and with it the spreader, are adjusted to give the desired width of hem, which having been effected, the nut J is tightened, and the machine is ready for the cloth, which is inserted in the usual way, and the hemming proceeded with in the manner familiar to operators.

I claim as new and of my invention—

The combination of slotted bracket E *e* with screws K K', slotted gage-plate F L, scroll-plate G M, spreader H O P Q, and tightening-nuts J and J', all constructed, arranged, and operating as described.

In testimony of which invention I hereunto set my hand.

JOHN F. JOHNSON.

Attest:

CHARLES H. WILLIAMS,  
GEO. H. KNIGHT.