

(No Model.)

W. N. EDSON.
INJECTOR OIL BURNER.

No. 407,065.

Patented July 16, 1889.

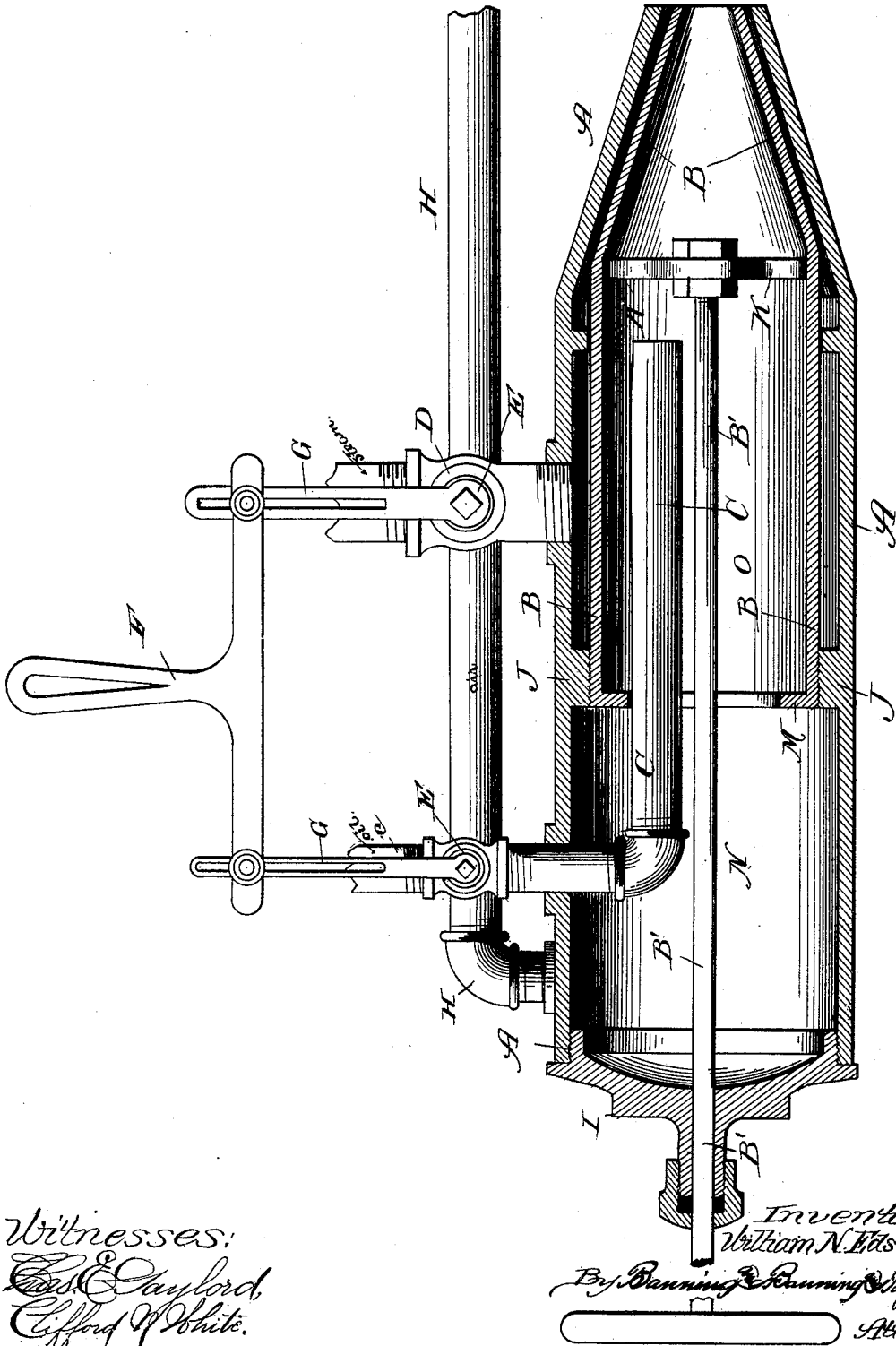

Witnesses:
Ed. Caylord,
Clifford White.

Inventor:
William N. Edson.
By: Danning & Danning, Attys.

UNITED STATES PATENT OFFICE.

WILLIAM N. EDSON, OF CHICAGO, ILLINOIS, ASSIGNOR OF ONE-HALF TO
SIMON FRANKENSTEIN, OF SAME PLACE.

INJECTOR OIL-BURNER.

SPECIFICATION forming part of Letters Patent No. 407,065, dated July 16, 1889.

Application filed December 18, 1888. Serial No. 294,017. (No model.)

To all whom it may concern:

Be it known that I, WILLIAM N. EDSON, a citizen of the United States, residing at Chicago, Cook county, Illinois, have invented a certain new and useful Improvement in Injector Oil-Burners, of which the following is a specification.

The object of my invention is to furnish a vapor-burner for use in furnaces, brick-kilns, limekilns, and generally wherever an intense heat is desired; and my invention consists in the features and details of construction hereinafter described and claimed.

The drawing represents a vertical section of my improved vapor-burner.

A is an outer shell or case; B, an inner adjustable shell or case; B', a rod fastened to the inner shell, whereby the same is adjusted; C, the oil-pipe; D, the steam-pipe; E E, cocks for closing such pipes; F, a hand-lever for turning the cocks; G G, slotted handles of the cocks; H, an air-pipe, and I a plug for closing the end of the outer shell or case.

In constructing my improved burner I make a shell or case A of any suitable material, and preferably about fourteen inches in length and three inches in diameter. This shell is preferably made in conical form for some distance at one end and closed by a screw-threaded plug at the other, as shown in the drawing. I then make another shell B of the same shape as the shell A, but shorter and of a smaller diameter and open at both ends, as shown. This latter shell is placed inside of the shell A and secured therein by means of the screw-threaded collar J. To furnish means for moving the shell B back and forth, I prefer to construct it with a web K, to which I firmly attach in any suitable manner the rod B'. This rod passes out through the plug I, which is provided with a stuffing-box to prevent the escape of oil, &c. As the rod B is turned it turns the shell B and moves it backward and forward by means of the screw-threaded collar. It is evident that the screw-threaded collar may be omitted and the cone moved backward and forward by providing the rod B with a screw-thread inside of the plug I, so that by turning the rod the cone would be moved back and forth without revolving; or any other suitable method of mov-

ing the cone may be employed, inasmuch as the important feature consists in having a movable cone.

By means of the two shells A and B three chambers are formed, the space L between the shells constituting the steam-chamber, the interior O of the inner shell constituting the oil-chamber, from which the oil is prevented from escaping by the flange M, and the remaining portion N of the outer shell forming the hot-air chamber.

The steam is admitted to the chamber L through the pipe D, and the oil to the chamber O through the pipe C. To admit air to the chamber N, I lead off the pipe H, which runs parallel to the shell A, to a point preferably in the same plane with the front end of the shell.

To simultaneously open or close the cocks E E, and to provide means whereby the relative amount of opening of such cocks may be regulated, I provide each of them with a slotted handle and connect the handles by means of the lever F, so that when the lever is moved it moves both handles at the same time.

The burner, being constructed as above described, is operated as follows: The conical end is inserted into the arch of a brick-kiln, or, when used with a furnace, through the furnace-wall beneath the boiler, or wherever the flame is desired, and secured in place by bolting the same to the outside of the furnace or securing it to the furnace or kiln by means of stay-rods or in any other suitable manner. The cocks being then opened, the oil enters the chamber O and the steam enters the chamber L and then rushes out of the annular opening between the shells. The steam surrounding the chamber L heats or vaporizes the oil, and as it rushes out of the annular opening acts in the manner of a siphon to draw the wholly or partially vaporized oil from the chamber O. The steam then mixes with it and the two enter the fire-chamber together, when the vapor is ignited and burned.

The amount of steam admitted to the fire-chamber is regulated by moving the shell B back and forth, thereby increasing or decreasing the size of the annular opening between the shells.

To provide for admitting the proper rela-

tive proportions of oil and steam to the burner, the lever F is so fastened in the slots of the handles G G that either of its ends can be raised or lowered independently of the other
 5 end. Whenever it is desired to increase the flow of steam or oil, one end of the lever is lowered in the slot in the handle of the steam or oil cock, thus diminishing the travel of such
 10 handle and decreasing the amount of opening of the cock, and when an increased amount of steam or oil is desired the travel of the handle and amount of opening of the cock are increased by raising the corresponding end of the lever F. This regulating of the relative
 15 proportions of steam and oil admitted by the burner is a very important feature of my invention, wherein it differs from all other inventions with which I am acquainted.

I am aware that various devices have been known and patented for moving or opening
 20 two or more cocks or valves simultaneously, and I do not claim this alone as any part of my invention; but what I do claim is so constructing the handles of the cocks and the lever by which they are connected that by a single motion of such lever I can admit a large amount of steam and a small amount of oil, or vice versa, as may be desirable at different times and under different circumstances.

The pipe H should enter the fire-chamber arch, or at least as far as the burner, and the outflow of steam and oil, exhausting the air in the chamber N, thereby draws heated air from the fire-chamber through the pipe H.
 35 This heated air, entering the chamber O, mixes with, further heats or vaporizes the oil, and passes out with the steam and oil into the fire-chamber. This providing the burner with a heated-air chamber N is another important feature of my invention, wherein it differs from all previous burners. As will be seen from the drawings, I draw by the action of the burner itself heated air from the furnace back through the pipe H, which air subsequently mingles with and superheats the
 45

oil, thus aiding materially the action of the burner.

If at any time it becomes necessary to clean out the interior of the shells, this may be done by unscrewing and removing the plug I. 50

Although I have described the two shells of my burner as being conical in part and prefer to so construct them, yet their shape may vary so long as the inner shell is adapted to move back and forth to increase or diminish the size of the opening between them, and various other changes of form or material may be made without departing from the spirit of my invention. 55

I claim— 60

1. In an injector oil-burner, the combination of an outer shell, an inner shell, means for adjusting such inner shell, a steam-pipe communicating with the outer shell, an oil-pipe extending within the inner shell, cocks in such pipes, and means for regulating the relative opening of such cocks, substantially as described. 65

2. In an injector oil-burner, the combination of an outer conical shell, an inner conical shell, means for adjusting such inner shell, a steam-pipe communicating with the outer shell, oil-pipe communicating with the inner shell, cocks for closing such pipes, and means for regulating the relative opening of such cocks, substantially as described. 70 75

3. In an injector oil-burner, the combination of an outer shell, an inner shell, means for adjusting such inner shell, a steam-pipe communicating with the outer shell, an oil-pipe entering the inner shell, and a hot-air pipe leading from the fire-chamber and communicating with the outer shell at a point near the rear end thereof, substantially as described. 80

WILLIAM N. EDSON.

Witnesses:

S. FRANKENSTEIN,
 GEO. S. PAYSON.